



Document Reference: XDS-GFS-00-001-R4

Functional Specification

110/220/400 kV Substation General Requirements

Revision History					
Revision	Date	Description	Originator	Checker	Approver
R0	31/08/2011	First Issue – This document supersedes 110kV Station General Requirements (XDS-WTS-00-001-R0) and 400kV Station General Requirements (XDS-ETS-01-001-R0). Sections 3.1.4, 3.2.2, 3.2.4, 3.2.5 and 7.6.1 were updated.	Paul Moran	-	Christy Kelleher
R1	10/01/2012	Dynamic Current (peak) for 400kV corrected to 125kA from typo 135kA	Paul Moran	-	Christy Kelleher
R2	01/05/2014	Sections 2, 3, 4, 5 and 6 updated	Sandra Howard	-	Paul Moran
R3	23/02/2015	Sections 3.1.4 and 4 updated.	Kieran French	-	Paul Moran
R4	19/12/2019	Major revision and update. Updates to sections: 1, 2.1, 3.1.1, 3.1.2, 3.1.3, 3.1.4, 3.1.5, 3.2, 3.2.1, 3.2.2, 3.2.4, 3.2.5, 3.2.7, 5, 5.2, 5.2.1, 5.3, 5.3.1, 5.4, 5.4.2, 5.6, 6.1, 6.2, 6.3, 6.4, 7, 7.1, 7.2.1, 7.2.3, 7.2.4, 7.2.5, 7.2.6, 7.2.7, 7.2.8, 7.2.9, 7.2.10, 7.2.11, 7.2.12, 8.1.1, 8.1.3, 8.1.5, 8.3, 8.4, 8.5, 8.7, 8.7.2, 8.8, 8.8.2, 8.8.4, 8.9, 8.9.1, 8.13 & 8.17. New sections added: 3.2.1.1, 3.2.3, 3.2.6, 3.2.8, 3.2.9, 4, 5.1, 5.1.1, 5.4.1, 5.5, 7.1.1, 7.2.2, 8.1.4, 8.1.6, 8.2, 8.8.3, 8.9.2 & Appendix A.	Conor Farrell / Kelvin McGurk	Due-diligence process and Philip Kennedy	Brendan Murray

COPYRIGHT © EirGrid

All rights reserved. No part of this work may be modified or reproduced or copied in any form or by means - graphic, electronic or mechanical, including photocopying, recording, taping or information and retrieval system, or used for any purpose other than its designated purpose, without the written permission of EirGrid

1	SCOPE	5
2	APPLICABLE SPECIFICATIONS AND STANDARDS	5
2.1	STANDARDS	5
2.2	UNITS OF MEASUREMENT	7
2.3	INTERCHANGEABILITY AND STANDARDISATION	7
3	FUNCTIONAL REQUIREMENTS	7
3.1	SERVICE CONDITIONS	7
3.1.1	GENERAL ENVIRONMENTAL CONDITIONS	7
3.1.2	INDOOR ENVIRONMENTAL CONDITIONS	8
3.1.3	OUTDOOR ENVIRONMENTAL CONDITIONS	8
3.1.4	CREEPAGE	9
3.1.5	NETWORK PARAMETERS	9
3.2	PHYSICAL DESIGN REQUIREMENTS	11
3.2.1	ACCESS REQUIREMENTS	11
3.2.2	SUBSTATION ARRANGEMENT	12
3.2.3	BUSBAR DESIGNATION AND PHASING	15
3.2.4	CLEARANCES	16
3.2.5	MECHANICAL LOADING	18
3.2.6	SERVICE CONTINUITY REQUIREMENTS FOR AIS SUBSTATIONS	19
3.2.7	WORKING CLEARANCES	19
3.2.8	FIRE SEPARATION CLEARANCES	21
3.2.9	WORKSHOP FACILITIES	21
4	INSPECTION AND MAINTENANCE REQUIREMENTS	22
5	HEALTH AND SAFETY REQUIREMENTS	23
5.1	PLANNING	24
5.1.1	NOISE	24
5.2	DESIGN	25
5.2.1	PROTECTION AGAINST MOVING EQUIPMENT	25
5.3	CONSTRUCTION	26
5.3.1	OFFICES, STORES AND WELFARE FACILITIES AND LAYDOWN AREA	26
5.4	COMMISSIONING	26
5.4.1	SUPPORTING ROLE	26
5.4.2	COMMISSIONING TESTING	27
5.5	TELEMESS REQUIREMENTS	27
5.6	COMPLETION / HANDOVER	27
6	CUSTOMER INTERFACE REQUIREMENTS	28
6.1	PHYSICAL INTERFACE	28

6.2	CIVIL INTERFACE	28
6.3	HIGH VOLTAGE INTERFACE	28
6.4	LOW VOLTAGE INTERFACE	28
7	QUALITY ASSURANCE	29
7.1	CUSTOMER'S RESPONSIBILITY	29
7.1.1	DESIGN REVIEW AND CONSTRUCTION MONITORING COMMENTS LOGS	30
7.2	SUBMISSIONS	31
7.2.1	GENERAL	31
7.2.2	DESIGN REVIEW	32
7.2.3	DRAWINGS	32
7.2.4	TECHNICAL DOCUMENTS AND CAD	32
7.2.5	SITE DOCUMENT FILE	33
7.2.6	OPERATION AND MAINTENANCE INSTRUCTION MANUALS	33
7.2.7	DOCUMENTATION TO BE SUBMITTED UPON PROJECT INITIATION	34
7.2.8	BEFORE MAJOR EQUIPMENT ORDERS	34
7.2.9	BEFORE THE DELIVERY OF EQUIPMENT	35
7.2.10	BEFORE COMMENCEMENT OF CONSTRUCTION	36
7.2.11	BEFORE EQUIPMENT ERECTION COMMENCES	36
7.2.12	BEFORE COMMISSIONING	36
7.2.13	BEFORE HANDOVER TO EIRGRID	37
8	GENERAL REQUIREMENTS	38
8.1	GENERAL TECHNICAL REQUIREMENTS	38
8.1.1	OIL AND GAS	38
8.1.2	PREVENTION OF ACIDITY	38
8.1.3	CORONA AND RADIO INTERFERENCE	38
8.1.4	CORROSION	38
8.1.5	WELDING	38
8.1.6	ELECTROMAGNETIC COMPATIBILITY	39
8.2	TOOLS, ACCESSORIES AND SPARE PARTS	39
8.3	WARRANTY	40
8.4	COMPLIANCE WITH SPECIFICATION	40
8.5	INSTALLATION	41
8.6	SERVICE EXPERIENCE	41
8.7	SIGNS, LABELS AND RATING PLATES	41
8.7.1	SUBSTATION SIGNS AND NOTICES	41
8.7.2	RATING PLATES	42
8.7.3	NAME PLATES	42
8.8	TESTS	43
8.8.1	TEST AND INSPECTION PLAN	43
8.8.2	FACTORY TESTS AND TYPE TESTS	43
8.8.3	DELIVERY	44
8.8.4	TESTS ON COMPLETION	44

8.9	TRAINING	45
8.9.1	ESB TRAINING	45
8.9.2	EIRGRID TRAINING	45
8.10	RESPONSIBILITY FOR FACILITIES AND SUFFICIENCY OF MEANS EMPLOYED	46
8.11	EQUIPMENT ON LOAN	46
8.12	CONTROL OF SITE	47
8.13	WORK PREPARED OFF SITE	47
8.14	CARE OF THE WORKS	47
8.15	SLIPS	47
8.16	SUPPORT OF WORKS AND ADJACENT STRUCTURES	47
8.17	CO-OPERATION WITH OTHER CONTRACTORS	47
9	APPENDIX	49

1 SCOPE

The following specification outlines the general requirements for the design and construction of EirGrid 110/220/400 kV transmission substations. This specification should be read in association with the project specific contestable works pack / document / CPP / SLD and all other relevant functional specifications as issued by EirGrid.

For the purpose of this specification the term Customer shall refer to any party (Independent Power Producers, Demand Customers, Transmission Asset Owner, or other developers) responsible for the design and build of assets for connection to the Irish transmission system.

2 APPLICABLE SPECIFICATIONS AND STANDARDS

2.1 STANDARDS

All installations shall comply with the latest version of the Grid Code. The Irish Grid Code is available on the EirGrid website www.eirgridgroup.com.

Except where otherwise stated in the functional specification, materials shall be designed, manufactured, tested and installed according to relevant IEC/EN standards. Where applicable the Irish adaptation of the standard (IS EN version), including any national normative aspects, shall apply. Where no IEC Standard has been issued to cover a particular subject then an EN, International or British Standard shall be applied. The latest edition and amendments shall apply in all cases. Where no IEC/EN standards have been issued to cover a particular subject a recognised international standard shall be applied.

IEC 50110	Operation of electrical installations
IEC 60071	Insulation co-ordination
IEC 60529	Degrees of protection provided by enclosures (IP code)
IEC 60617	Graphical symbols for diagrams
IEC 60815	Selection and dimensioning of high-voltage insulators intended for use in polluted conditions
IEC 60865	Short Circuit Currents – Calculation of effects
IEC 61936	Power installations exceeding 1 kV a.c. Common rules
IEC 62474	Material declaration for products of and for the electrotechnical industry
IEC Guide 113 ed1.0	Materials declaration questionnaires - Basic guidelines
ISO 9001:2000 (or later)	Quality Management Systems
	Safety Health & Welfare at Work Act 2005

Safety Health & Welfare at Work (Construction) Regulations 2013

SI No. 132/1995 Safety Signs at places of Work Regulation 1995

SI 176/2010 Safety, Health and Welfare at Work (General Application) (Amendment) Regulations 2010

SI No 299/2007 Safety, Health and Welfare at Work (General Application) Regulations 2007

EU ROHS (2002/95/EC) and WEEE (2002/96/EC) Directives published in January 2003

EU Construction Products Regulation (No. 305/2011 – CPR)

CLP (Classifying, Labelling, Packaging) Regulation (EC) No 1272/2008

EN ISO 3746 Acoustics – determination of sound power levels and sound energy levels of noise sources using sound pressure – survey method using an enveloping measurement surface over a reflecting plane.

EN ISO 9614 Acoustics – determination of sound power levels of noise sources using sound intensity – Series

ET101:2008 National Rules for Electrical Installations Power installations, 4th Edition (Including A1:2011 Amendment No.1)

ET103:2015 National Rules for Electrical Installations Power installations exceeding 1 kV a.c. (1.5 kV d.c.), 1st Edition

The design of the substation, and the plant and equipment supplied and installed used shall comply (in order of precedence) with the requirements of:

1. National, European or International legislation;
2. EirGrid Grid Code and Functional Specifications;
3. IEC/EN standards;
4. Other international standard.

In case of conflict between this specification and any other IEC or relevant specifications, the requirements of this specification shall take precedence; however the Customer may seek a clarification to any conflict if necessary.

The Customer shall state in his proposal the standards and codes of practice which he proposes for any items of plant not covered by IEC standards. If required by EirGrid, the Customer shall submit two English language copies of these standards not later than the design submission date.

Where appropriate, the equipment shall carry the CE Mark in accordance with Directive 768/2008/EC and the EU Construction Products Regulation (No. 305/2011 – CPR) and sufficient documentation to demonstrate full compliance shall be retained.

The complete construction site electrical infrastructure shall be installed in accordance with the latest addition of the National Rules for Electrical Installations ET101:2008 or with the I.S. 10101 when it becomes valid. At the end of construction and commissioning all temporary electrical equipment including cabling shall be removed.

2.2 UNITS OF MEASUREMENT

The SI system of units shall be used throughout the project.

Temperature shall be in degrees Celsius.

Electrical energy shall be in kWh and gas and fluid pressure shall be expressed in MPa.

2.3 INTERCHANGEABILITY AND STANDARDISATION

To limit the stock levels of spare parts required, all equipment and parts thereof performing similar duties shall preferably be interchangeable.

3 FUNCTIONAL REQUIREMENTS

3.1 SERVICE CONDITIONS

3.1.1 GENERAL ENVIRONMENTAL CONDITIONS

The Customer shall comply with all aspects of Irish legislation (in addition to the relevant European legislation) in relation to the environment during all phases of the project. A complete list of current environmental legislation is available on the Irish Government's website (<http://www.irishstatutebook.ie>).

The Customer shall prepare a Construction Environmental Management Plan (CEMP) for the project. The CEMP shall be prepared to accord with and include:

- planning/permit/consent application documents (including the Environmental Impact Assessment Reports, Appropriate Assessment Reports and other environmental reports)
- conditions of permission/permit
- pre-commencement submissions
- Building Research Establishment Environmental Assessment Method (BREEAM) requirements
- legislation, published guidelines and codes of best practice

The Customer shall notify EirGrid if any correspondence and/or statutory notices, non-compliances or observations received from the Environmental Protection Agency and/or National Parks & Wildlife Service and/or National Monuments Service and/or local authorities and/or any other statutory body in respect of any licence, consent, permission and/or permit and/or arising from the construction of the works.

The site climatological conditions shall be taken into consideration when designing the substation. The climate in Ireland is moderate and extreme temperatures are very rare, and the equipment to be provided shall be capable of operating satisfactorily under the conditions likely to be encountered on site.

3.1.2 INDOOR ENVIRONMENTAL CONDITIONS

The following service conditions apply to all indoor equipment:

Maximum ambient temperature	+ 40 °C
Maximum daily average ambient temperature	+ 30 °C
Annual average ambient temperature	+ 20 °C
Minimum ambient temperature	- 5 °C
Humidity	95%

The indoor equipment to be provided shall be capable of operating satisfactorily at these temperatures, and their ratings at these temperatures shall also be stated. Condensation in Switchgear Rooms may occur.

3.1.3 OUTDOOR ENVIRONMENTAL CONDITIONS

The following outdoor air temperatures apply:

Maximum ambient temperature	+ 40 °C
Maximum daily average ambient temperature	+ 30 °C
Annual average ambient temperature	+ 20 °C
Minimum ambient temperature	- 25 °C

Equipment will also be exposed to:

- Average Solar Radiation of 420 – 870 W/m²
- Maximum wind (3-second gust) velocity of 50 metres per second.
- High Humidity of up to 95%, salty, highly corrosive atmosphere which is particularly severe on non-galvanised ferrous parts and aluminium and its alloys.
- There is a high incidence of wind-driven rain, with a rainfall average of 1000 mm per annum.
- The rainfall frequency is typically once every two days on average.

3.1.4 CREEPAGE

The values for the required creepage shall be as identified in the Project Specific Functional Specification. Outdoor insulators shall be suitable for site pollution severity (SPS) class d – Heavy in accordance with IEC 60815-1 (RUSCD 43.3 mm/kV).

In certain cases SPS class e - very heavy (RUSCD 53.7 mm/kV) may be required. Customers to consult with EirGrid Client Engineer to confirm if very heavy class is required.

The final minimum creepage distance shall be calculated using the method given in IEC 60815-2 or 60815-3 for HV plant.

3.1.5 NETWORK PARAMETERS

The system design information is as per **Table 1** below:

Table 1 : Network Parameters

Description	110 kV	220 kV	400 kV	LV aux
Nominal Voltage	110 kV	220 kV	400 kV	400 / 230 V \pm 10%
Highest Network Voltage	123 kV	245 kV	420 kV	440 V / 253 V
No. of Phases	3	3	3	3, 4 wire
Frequency	50 Hz	50 Hz	50 Hz	50 Hz \pm 2.5 %
Neutral Point	Directly Earthed at selected points	Directly Earthed at selected points	Directly Earthed at selected points	Directly Earthed
3 Phase Short Circuit Level (rms)	31.5* kA	40 kA	50 kA	16 kA [†]
Duration of Short Circuit [‡]	1 s	1 s	1 s	1 s
Peak Short circuit current (peak)	78.75* kA	100 kA	125 kA	N/A

* 3 phase short circuit level (rms) and peak short circuit current ratings are based on typical system fault levels and X/R values. In certain designated substations (i.e. Dublin region) X/R values may necessitate higher equipment ratings being required. The Customer shall clarify with the EirGrid project team if a special case d.c. time constant (X/R ratio) or **short circuit level** is applicable for the respective project. (This potential increase in short circuit level would also impact other design activities such as Earthing design).

The Customer shall provide evidence that the selected equipment meets both the a.c. and d.c. short circuit current requirements for make and break duty.

[†] This is the standard value for design of LV equipment in Transmission substations based on a standard rural supply. A higher value may apply due to supply from ESBN Industrial connection (up to 37 kA).

[‡] This value is the maximum, to be used for equipment withstand purposes. Alternative clearance times and network parameters shall be considered for various protection and earthing calculations in accordance with the relevant functional specifications.

For AIS designs the specified minimum 3 Phase Short Circuit level (rms) applies for both electrical and mechanical forces. To comply with the mechanical aspect of this, the Customer must submit HV conductor loading calculations as per the latest revision of IEC 60865.

A typical system X/R ratio of 14 shall be considered except in the following circumstances:

- Designated substations, where a higher value has been outlined.
- CT suitability calculations where a minimum value of 25, or as outlined in the project protection specification, shall apply.
- Busbar forces calculations, where a minimum value of 25 shall apply.

The Customer shall consider the capacitive and inductive switching requirements in accordance with the project specific requirements and the relevant functional specification for the switching devices.

Table 2 indicates values for minimum insulation levels:

Table 2: Insulation Levels

Description	110 kV	220 kV	400 kV
Rated voltage (U_r) kV (rms)	123	245	550
Rated power frequency withstand voltage			
(U_d) kV (rms) Phase–earth & phase-phase	230	460	620
(U_d) kV (rms) Across isolating distance	265	530	800
Rated lightning impulse withstand voltage			
(U_p) kV (peak) Phase–earth & phase-phase	550	1050	1550
(U_p) kV (peak) Across isolating distance	630	1200	1550 (+315)*
Rated switching impulse withstand voltage			
(U_s) kV (peak) Phase–earth	-†	-**	1175
(U_s) kV (peak) Phase–phase	-**	-**	1760
(U_s) kV (peak) Across isolating distance	-**	-**	900 (+450)§

In the case of 110 kV and 220 kV no switching impulse level is assigned and the clearances are dictated by the BIL.

LV equipment shall have rated power frequency withstand rating of 2 kV (rms) for 1 minute. This has an equivalent rating of 3 kV across the isolating distance.

* Note: The values in parentheses are the peak values of the a.c. voltage applied to the opposite terminal.

† Although there are no standard switching impulse withstand requirements at this voltage level, particular plant (e.g. Transformers or Capacitor banks) may have a particular withstand requirement.

3.2 PHYSICAL DESIGN REQUIREMENTS

This section relates primarily to new substations and significant substation redevelopment projects.

Development within existing substations shall make all reasonable efforts to bring the substation in line with these requirements and all new equipment shall be compliant.

3.2.1 ACCESS REQUIREMENTS

It shall be possible to gain access to the substation for maintenance and operation purposes. This shall be unrestricted 24/7 access.

Access shall be provided by an access road and bridges (where road crosses ditches and streams or creek), suitable for carrying maintenance vehicles and trucks from a public roadway to the substation gate.

Access into the substation shall be provided for by a double gate which opens inwards. Access within the substation shall be provided by means of a 4.5 m wide road entrance.

Access within the substation around the equipment and buildings shall be provided for by means of suitable access ways and turning circles for maintenance vehicles and trucks and doors on the buildings suitable for allowing access to the equipment housed inside.

The site and access route shall be designed to allow suitable access for required cranes and typical construction and maintenance vehicles (7 tonne axle weight) to all pieces of plant within the compound.

LV cable trenches shall be arranged to minimise restriction of vehicular access to the HV plant. The electrical design shall be fully co-ordinated with the civil design to ensure that trafficable and non-trafficable areas of trenching are clearly identified.

Confined spaces give rise to significant risk. Where practicable, designs should be such that the need for work in confined spaces is avoided. Where this cannot be achieved, substation physical design requirements shall be such that the guidelines contained in the latest revision of the HSA (Health and Safety Authority) Code of Practice for confined spaces are incorporated into the substation design where applicable.

Where there is equipment on both sides of a passageway the passageway shall have a minimum width of 1.2 m. Other passageways shall have a minimum width of 1 m.

Doors shall be arranged to open in the direction of any escape route. Equipment panel doors shall be arranged so that they do not impede any emergency escape route.

Detailed requirements for the fences (palisade & boundary), gates and buildings are listed in the Contestable Works Package. Standard detail drawings are also included in the Contestable Works Package.

3.2.1.1 NOTE ON BATTERY ROOMS

Particular consideration shall be given to providing suitable access and working clearances around batteries. A minimum of 1m between parallel racks of batteries shall be provided.

Suitable clearances shall also be provided between batteries (including isolated battery stands) and any nearby earthed metalwork to prevent inadvertent earthing.

3.2.2 SUBSTATION ARRANGEMENT

To ensure consistency, a standard approach to substation layout based on a defined orientation shall be adopted. This orientation shall be defined by a reference point and forward direction as per Table 3. Sample illustrations in Figure 1 to Figure 4: 4 are for information only. For scenarios outside those shown below, or in case of doubt, clarification shall be provided by EirGrid.

Table 3 : Substation Orientation Convention

Figure	Scenario	Reference point	Forward direction
1	Multiple voltage substation	An observer standing midway between the highest voltage and second highest voltage busbars	Facing the highest voltage busbars
2	AIS Single voltage substation	An observer standing at the central Control & Protection building*	Facing the high voltage switchgear
3	GIS Single voltage substation	An observer standing at the operational side of the Switchgear	Facing the high voltage switchgear†

* Where there are multiple control rooms or where the location of the control building would cause the forward direction to be perpendicular to the main busbar, the location of an alternative reference point shall be confirmed by EirGrid on a case by case basis.

† Note: If the GIS LCCs are mounted separately and opposite the switchgear, the forward direction / operational control should be such that an observer standing in the centre of the station facing the LCCs will see LCC bays to the left of the mid sectionaliser given odd numbers and those to the right even numbers. This scenario is illustrated in Figure 4.

110/220/400 kV00 - Station General Requirements

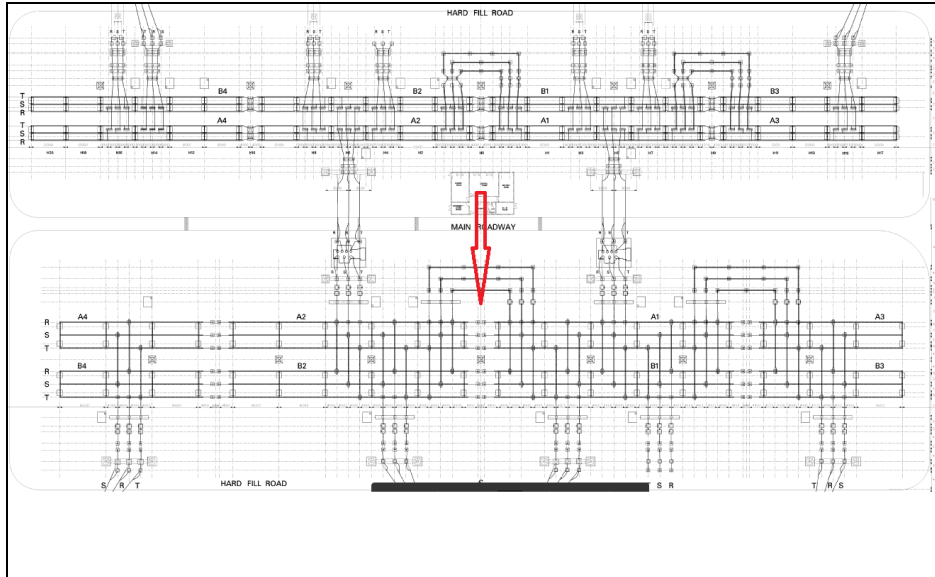

Figure 1: Orientation for bay designations - Multiple voltage AIS substation

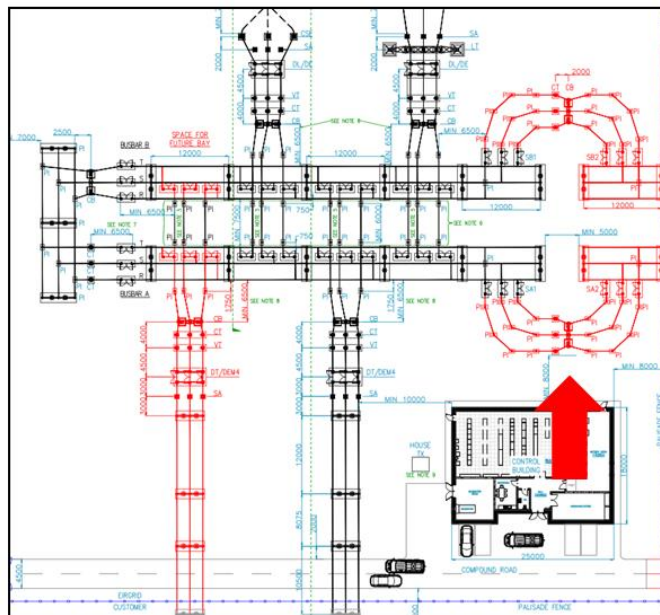

Figure 2: Orientation for bay designations - Customer Substation AIS

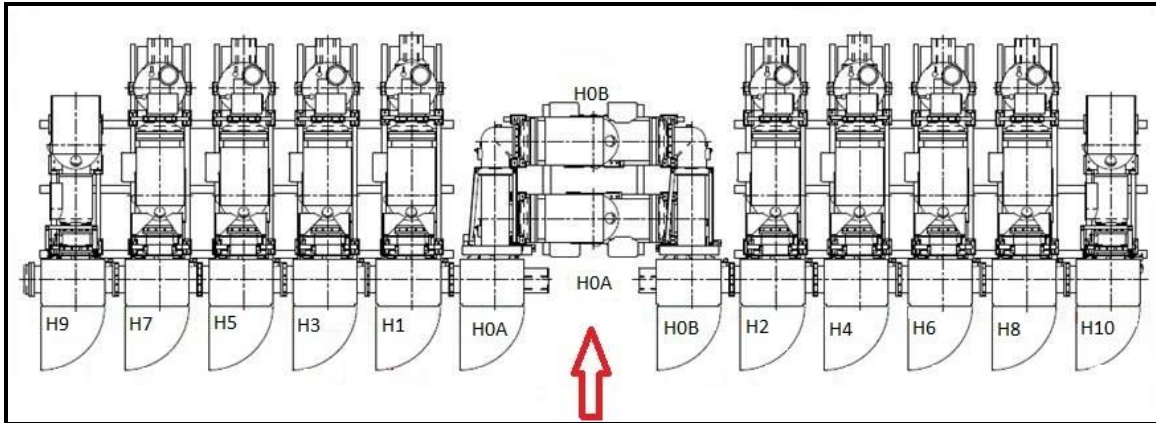

Figure 3: Orientation for bay designation - GIS with integrated LCC

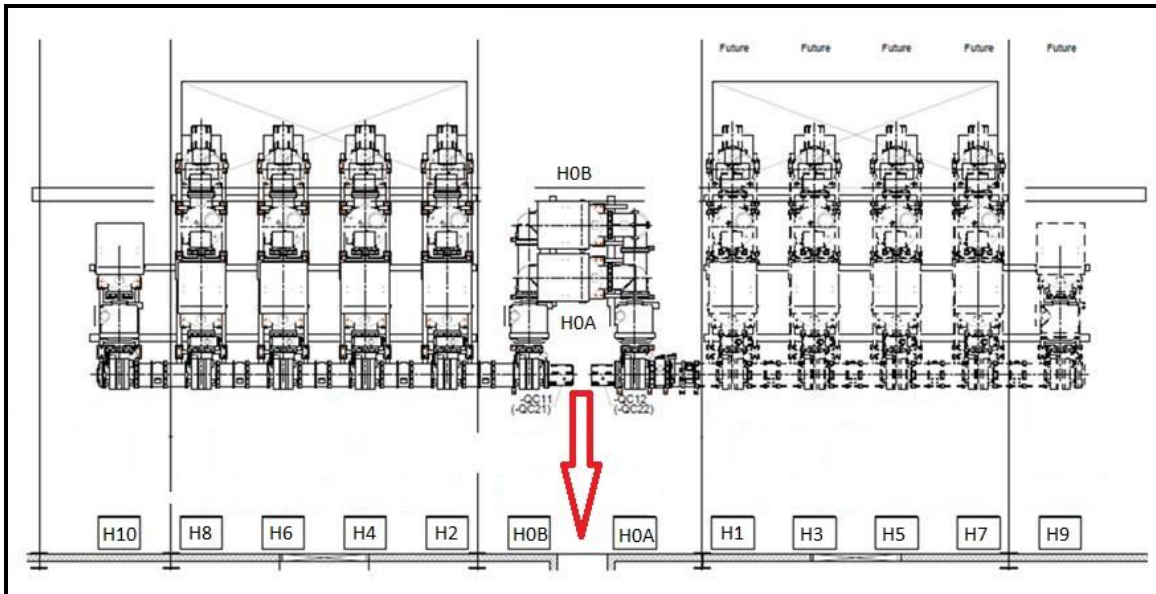

Figure 4: Orientation for bay designation - GIS with standalone LCC separate/opposite switchgear

The central sectionaliser circuit breaker bay (H0A/H0B, F0A/F0A, E0A/EOB depending on voltage) shall be defined as the midpoint of the busbar in a standard substation.

EirGrid shall advise on a case by case basis where there are more than 2 sections of busbar which sectionaliser shall be considered as central.

The bays to the left of the central sectionaliser shall be given odd numbers and those to the right even numbers.

Busbar sections to the left of the central sectionaliser shall be given odd numbers and those to the right even numbers.

Transformers to the left of the central sectionaliser shall be given odd numbers and those to the right even numbers.

In double busbar AIS substations the nearer busbar shall be designated A and the other B.

GIS substation busbar arrangements shall be arranged depending on the specific requirements of the switchgear type. In general the nearer or lower busbars shall be A and the other B.

In GIS substations the A sectionaliser shall be to the left / nearer / below the B busbar sectionaliser depending on the requirements of the particular switchgear.

In the case of existing (brownfield) substations, consistency with existing substation orientation and naming convention shall take precedence over this specification unless explicitly agreed with EirGrid.

Phasing within the feeder (including transformer, reactor, filter etc.) bays shall be arranged based on the connected line, cable or plant to avoid unnecessary transposition of conductors. Where phase transpositions are required, these shall be done outside the substation on the respective feeder.

The Customer shall confirm and verify phase arrangement with relevant site visits and as-built documentation.

3.2.3 BUSBAR DESIGNATION AND PHASING

In single or double busbar AIS substations the nearest busbar phase to the reference point shall be R, then S and T.

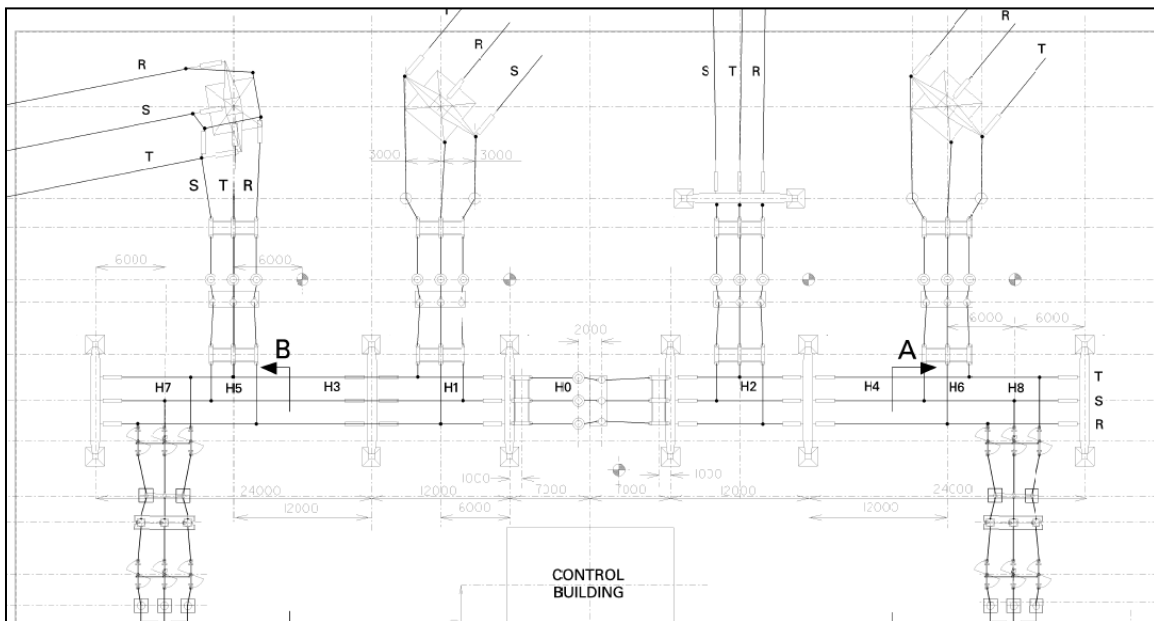

Figure 5: Example Busbar Phasing of AIS substation layout

3.2.4 CLEARANCES

Minimum clearance distances for the rated voltage conditions must be maintained to ensure appropriate insulation co-ordination between different live parts and also between live parts and ground. These clearances must be applied throughout the installation. Smaller clearances are only accepted where the arrangement concerned has been tested in accordance with the prescribed insulation test.

Adequate safety clearances shall also be taken into account. Safety clearances are the distances in air that must be applied in the design of an installation to allow personnel safe access to install, operate, maintain, repair and demolish equipment in the vicinity of live equipment/conductors.

These must allow for the:

- Effect of swinging conductors due to cross-winds (reduced clearance per IEC is acceptable).
- Effect of swinging conductors short circuit (a 50% reduction in clearance during short circuit may be permitted).
- Sagging of stranded conductors due to increased temperature or to ice load.
- Disconnecter arms in the open position.

Lower clearance values may be accepted on manufactured equipment if the equipment has been subjected to the appropriate insulation type tests. This is subject to formal agreement with EirGrid.

Clearance between live parts of the same insulation level which may be operated out of synchronism shall be a minimum of 1.2 times the normal phase to phase value*.

The mandatory minimum electrical clearances in air are shown in Table 4.

* Note: An exception may be permitted, by agreement, in the case of a tested item of plant. (e.g. Circuit Breaker where the clearance between conductors on each side shall be not less than the clearance across the Circuit Breaker chamber). Such instances shall be brought to the attention of the EirGrid Client Engineer.

Table 4 : Minimum clearances in air

Item	Description	Clearance (mm) @ 400 kV	Clearance (mm) @ 220 kV	Clearance (mm) @ 110 kV
1	Phase-earth* (Basic electrical clearance in air)	4100	2400	1100
2	Phase-phase (Basic electrical clearance in air)	4750	2700	1100
3	Minimum height of bottom of unscreened live bushings above ground†	2300	2300	2300
4	Minimum height of live parts above pedestrian passageway	6400	4700	3400
5	Minimum height of live parts above vehicle Passageways	10500	9000	8000
6	Minimum height of lines above ground (other than the road)	9000	8000	7000
7	Minimum height of compound fence	2600	2600	2600
8	Minimum horizontal distance between live parts and compound fence‡	5600	4500	4500
9	Minimum distance from live parts to screens, walls etc	4200	2500	1200
10	Minimum Clearance between a substation and a wind turbine	Twice the falling distance of the turbine		
11	Live part to a wall (>2300 mm height)	4100	2400	1100
12	Live part to a screen (>2300 mm height)	4200	2500	1200
13	Clearance across an open break	5700	3240	1320
14	Radial limit of close proximity (CPZ)	3500	2100	1200

* Phase-phase and phase-earth clearances do not apply to manufactured equipment which has been tested to prove compliance with the rated insulation level.

† For low level mounted HV AIS equipment where the bottom of insulator <2300 mm above ground, and >1 kV e.g. HV capacitor banks, SVC, STATCOMs, HV reactors etc. Access gates or panels shall be secured using fixing bolts at minimum of 2 no. fixing points and shall not be secured with a lock.

‡ The minimum horizontal distance between live parts and compound fence/wall prescribed above is the minimum clearance required to guard against anyone outside a boundary fence being able to come into contact with live equipment. The space between a boundary fence and live equipment may also be needed for use as a vehicle passageway for construction or maintenance purposes. If this access is to be used without needing an outage of the relevant HV equipment then the clearance may need to be increased and/or appropriate screening measures installed.

New substations shall be located away from existing overhead electrical Transmission or Distribution lines not terminating within the substation. A minimum separation distance (from the compound fence to the nearest phase conductor of the OHL) of twice the height of the tallest point on the OHL infrastructure shall apply. The OHLs approaching the station shall be routed not to sterilise the land reserved for the ultimate development of the station.

Proximity and approach of lines terminating at the substation shall be by agreement with EirGrid, however, sections of lines running parallel to the compound fence shall respect the above separation distances as far as practically possible.

For clearance requirements of wind turbines to overhead line infrastructure please refer to latest EirGrid policy document Policy_15_Wind_Turbine_Clearance.

3.2.5 MECHANICAL LOADING

The most extreme of the below listed conditions shall be used to calculate the loads imposed by conductor on support structures:

Table 5 : Mechanical Loading on Conductors

Item	Temperature	Ice Thickness (mm)	Wind speed (m/s)
1	-20	0	0
2	0	40 (stranded) 10 (tubular)	0
3	0	25 (stranded) 6.25 (tubular)	25

A design wind velocity based on the maximum 3 second gust value (as outlined in section 3.1.3) shall be used to calculate the effect of wind load on all structures. Design loads shall not exceed the failure strength of the structure. All designs shall be submitted to EirGrid for review.

3.2.6 SERVICE CONTINUITY REQUIREMENTS FOR AIS SUBSTATIONS

The following minimum service continuity requirements shall apply.

- All circuit bay equipment (i.e. circuit breaker, instrument transformers, disconnectors, Earth switches, surge arresters, post insulators etc.) excluding busbar disconnectors & associated connections shall be capable of being maintained, repaired, removed and replaced without the need for busbar or adjacent circuit outages.
- In the case of double busbars, equipment associated with a particular busbar section (including busbar, post insulators and busbar disconnectors) shall be capable of being maintained, repaired, removed and replaced without the need for adjacent busbar* or unnecessary adjacent bay outages.
- Work on high level busbar equipment (busbar conductor, supports etc.) may necessitate circuit outages where the low level circuit bay conductor span crosses underneath the associated busbar between busbar disconnectors DA and DB.

3.2.7 WORKING CLEARANCES

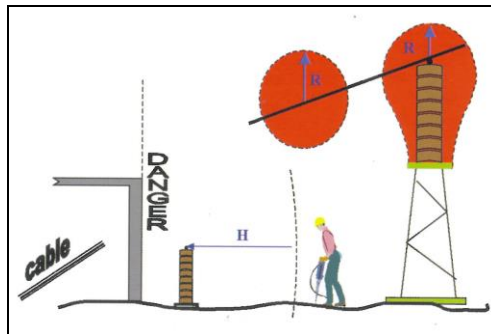

Figure 6 : Limits of Close Proximity (CPZ)

Due consideration shall be given to the implementation of Designated Works Areas (DWA). The DWA is the standard ESNB procedure to control the risk of coming into contact with live electrical equipment. The DWA is an essential control necessary to enable safe completion of work.

This is achieved by establishing a physically defined area within which it is safe to undertake maintenance, modification or other work.

The Customer's design shall take into account the following:

- The need to define these areas for all works during the lifetime of the substation (following initial energisation).
- How the DWA will be arranged for any foreseeable maintenance and modification works.

* i.e. A1 remains in service while working on B1.

Further information in relation to secure and unsecure barriers and elevated working platforms can be provided by request via the EirGrid Client Engineer.

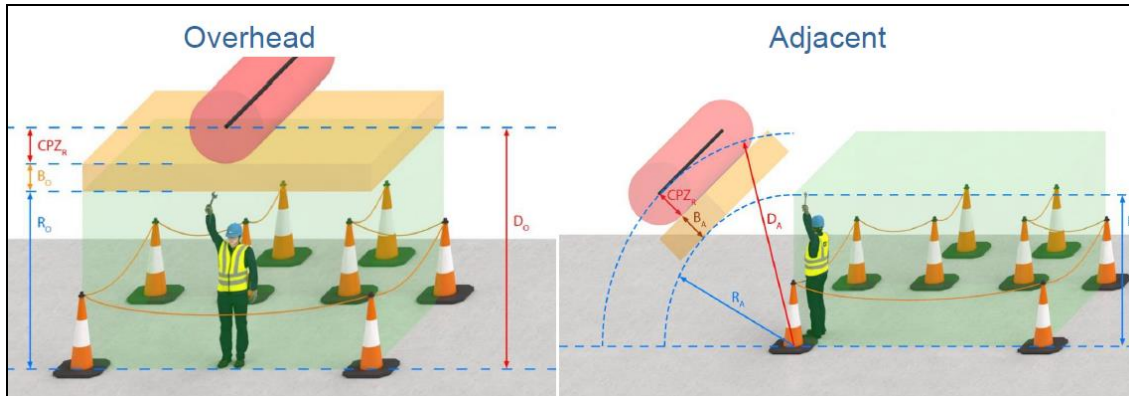

Figure 7: DWA showing Safe Working Area, Close Proximity Zone and Buffer

The Close Proximity Zone (CPZ) around an exposed high voltage conductor is defined by the radial limits further outlined in the ESB Electrical Safety Rules (blue book).

CPZ shall also apply at insulators and bushings where a voltage gradient may be present; this is shown in Figure 6 .

The extent of the safe working area shall include consideration of issues associated with secure and unsecure barriers and platforms.

Design shall seek to provide 2 m clearance (buffer) between the expected safe working area and the CPZ of any adjacent parts which would be live under a minimum isolation outage. The expected DWA envelope shall not extend into the CPZ of the adjacent live parts.

The designer shall also consider the use (and where appropriate any insertion, removal, and storage) of any operating handles with the associated plant in the energised state.

Equipment layout designs shall mitigate against any unnecessary / avoidable prolonged outages including parallel sections of busbar being on outage.

Design shall consider the safe working area required using typical tools and access associated with installation, operation, maintenance and decommissioning of all plant.

The Customer shall provide details of their proposed approach to facilitate the design life of the substation including features permitting the replacement of components. The designer shall clearly indicate any assumptions or limitations in relation to how these works are expected to be performed.

For GIS layouts, further requirements are outlined in EirGrid functional specification XDN-GFS-25-001.

Further details on inspection and maintenance requirements can be found in section 4.

The designer shall also consider any potential future extension of the substation as outlined in the Connection Agreement or Committed Project Parameters. For example extension from a "C" type substation to an "Enhanced Ring" configuration may utilise separate short busbar section outages on the A and B bars in turn but not simultaneously (i.e. no half station outages).

3.2.8 FIRE SEPARATION CLEARANCES

The required separation clearances in outdoor installations between a transformer (includes reactors or other items of plant containing a minimum of 1000 litres of flammable liquid) and other transformers or objects shall be in compliance with IEC 61936-1.

If the fire separation clearances are not achievable then fire-resistant separating walls or fire-resistant construction are required.

Fire separation clearance is not required between a transformer and any equipment which is directly associated with that transformer.

The consideration of reduced clearances based on automatically activated fire extinguishing equipment is not permitted.

Clearances between buildings and to property boundaries shall be in accordance with the requirements of the Irish Building Regulations (Technical Guidance Document B - Fire Safety (2006)).

3.2.9 WORKSHOP FACILITIES

A suitable workshop shall be provided to cater for storage of earthing stirrups and earth parking bars in accordance with the requirements of functional specification XDS-GFS-12-001 to allow application of portable earthing sets on AIS equipment.

The workshop will also include a work bench and will be sized sufficiently to store all necessary tools and equipment for the lifecycle of the equipment.

Proposals for the storage of these and other tools/accessories (e.g. switchgear tools, battery tools / accessories, etc.) shall be submitted to EirGrid for review.

4 INSPECTION AND MAINTENANCE REQUIREMENTS

The station and associated assets shall be subject to regular local operation, inspection and maintenance intervals in accordance with EirGrid asset management policies.

Refer to EirGrid Asset Maintenance Policy document **TAM-AMP-2008-I01**.

The Customer shall consider, as a minimum, the activities described in this policy document taking into account the tasks to be performed and their expected frequency. These activities shall be included in the Customer's formal Design Risk Assessment for the installation as a whole to ensure safe operation, inspection and maintenance can be carried out throughout the lifetime of the installation without undue risk to the personnel involved in these activities.

Any additional inspection and maintenance recommendations for the installation shall be identified by the Customer and incorporated into the maintenance requirements for the particular installation to be included in the associated safety file.

The Customer shall develop and issue an inspection and maintenance layout drawing illustrating that all HV equipment can be safely maintained.

5 HEALTH AND SAFETY REQUIREMENTS

The Customer will be assumed to be the Client in the context of the applicable statutes*.

The Customer shall comply, at all times, with all statutory duties or provisions imposed upon them by any current Legislation, new Legislation or amendments to Legislation as these may occur during the Project, specifically:

- The installation shall comply with the Safety, Health and Welfare at Work (General Application) Regulations 2007, in particular Part 3: Electricity. In these documents, 'higher voltage' means any voltage exceeding 1000 V a.c. or 1500 V d.c.
- The Safety, Health and Welfare (Construction) Regulations 2013 (S.I. 291 of 2013)
- EU ROHS (2002/95/EC) directive
- WEEE (2002/96/EC) Directives published in January 2003
- REACH Regulation (Regulation (EC) No.1907/2006)
- CLP Regulation (EC) No.1272/2008

In making the required statutory appointments the Customer shall assure itself of the Competence of such appointees.

Where such appointments are internal the Customer shall ensure that sufficient resource, including competent personnel are available and that no conflict of interest arises during the Project.

All required appointments shall be made in a timely fashion.

The Customer shall provide manufacturer's declaration of materials in accordance with IEC 62474. Such material declarations shall include any regulatory exemptions that are applicable to the use of declarable substances and declarable substance groups.

The Customer shall also ensure that all relevant requirements of local and national planning and environmental agencies are built into the design and build as necessary.

The Customer shall submit the equipment manufacturer's declaration of all substances classified as hazardous in the equipment proposed to EirGrid for review. These materials may be either hazardous to health (e.g. carcinogens, toxic, radioactive, dermatitis-inducing) or to the environment (e.g. contribute to global warming, ozone depletion, water pollution).

The Customer shall submit a proposal of how known hazardous substances such as excess or redundant SF6 gas or contaminated oil shall be managed during the project based on risk assessments to EirGrid for review.

The Customer shall submit the equipment manufacturer's Safety Data Sheets for hazardous substances used in the equipment to EirGrid for review. They shall be classified in accordance with Safety, Health and Welfare at Work (General Application) Regulations 2007 (S.I. 299 of 2007) and SI 176 (2010) Amendment. This also refers to packing waste that can have associated biological issues such as transmission of disease or introduction of unwanted flora and fauna.

5.1 PLANNING

In all cases, the Customer is responsible for ensuring compliance with relevant planning and legislative requirements.

It is the responsibility of the Customer, to prepare the planning permission application, to apply for planning permission, and to obtain full planning permission without restrictive conditions for the substation and associated works.

The Customer shall submit to EirGrid all planning permission documentation associated with all plant to be built including all submittals required in connection with protection of the environment.

The Customer shall submit to EirGrid any documents revised or updated as a result of any change and/or update to any of the required documentation submitted as part of the planning application.

5.1.1 NOISE

The Customer shall take all reasonable measures to ensure that the noise arising from site activities and operational plant and equipment shall not exceed the noise level exposure limits for general work areas as specified in the Safety, Health and Welfare at Work (General Application) Regulations 2007.

Noise level exposure from the site shall also comply with any conditions of the planning permission or other local authority or Environmental Protection Agency requirements.

The Customer shall be responsible for all necessary background, construction and operational measurements to demonstrate compliance.

Procedures for the purpose of determining compliance with the neighbourhood noise limits shall be submitted to, and agreed in writing with, the relevant Planning Authority. The Customer shall provide a copy of these agreed procedures if requested by EirGrid.

Silencing equipment (e.g. noise enclosure) shall be provided for equipment where required. Any silencing equipment used shall meet the requirements of this specification and the relevant individual EirGrid functional specifications.

5.1.1.1 SAFETY LIMITS

The Customer shall bring to the attention of EirGrid, any items of plant or operating scenarios which are likely to cause the lower exposure action value ($L_{EX,8h} = 80 \text{ dB(A)}$) to be exceeded. The customer shall provide a noise risk assessment and clearly outline the proposed mitigation for all such items of plant or operating scenario.

5.1.1.2 NEIGHBOURHOOD NOISE

Notwithstanding any local planning limits, the following ESB neighbourhood noise level limits shall apply at the property boundary or nearest inhabited dwelling*:

- Day time (08:00 -22:00 all days) 55 dB(A) LArT
- Night time (22:00 -08:00 all days) 45 dB(A) LAeq

No high-frequency pure tone components shall be produced from the plant operating in any mode during night-time hours. If a tonal noise is produced during day-time or evening hours then a 5 dB penalty shall apply to the noise contribution from the plant.

All neighbourhood sound measurements shall be carried out in accordance with ISO 1996: Acoustics – Description, Measurement and Assessment of Environmental noise.

5.2 DESIGN

The Customer shall ensure that all functional designs are prepared by a competent Designer(s), to meet the requirements of the Functional / Operational Specifications issued by EirGrid. In commissioning the preparation of any Design the Customer shall ensure that any relevant information, which may have a material effect on the Design or Construction phase of the Project is provided in a timely manner to all parties.

The customer shall demonstrate that the design, construction, testing and installation of any asset connecting to the high voltage transmission system is safe by design and residual risks are sufficiently identified to allow for the safe energisation, operation, maintenance and decommissioning of the asset.

Please refer to EirGrid's Safe by Design Methodology (XDS-SDM-00-001) for further details.

5.2.1 PROTECTION AGAINST MOVING EQUIPMENT

Shafts, belts, pulleys and other moving parts shall be provided with guards which shall provide a degree of protection IP2X according to IEC Publication 60529.

* If a dwelling already exists near the property or there are reasonably expected future dwellings (i.e. known development or zoned residential area), then these shall be considered as the nearest inhabited dwelling.

5.3 CONSTRUCTION

The Customer shall ensure that Construction work is carried out with due regard for the health, safety and welfare of anyone who may be affected by the works, this will include, as appropriate, workers, contractors, 3rd parties and members of the Public; and in compliance with statutory requirements.

Where Construction work, or any element of, is to take place within an existing Electrical Transmission Substation then all works will be planned and carried out in accordance with the ESB Networks "Electrical Safety Rules 2006" and ESB Networks Specification 01601.

On site audits or inspections may be carried out by independent Engineering Representatives to ensure compliance with statutory provisions and agreed engineering design(s) and / or specifications. The Customer shall ensure that such Representatives have unrestricted access to the Project as required to allow them to carry out this role.

5.3.1 OFFICES, STORES AND WELFARE FACILITIES AND LAYDOWN AREA

The Customer shall provide their own temporary site offices and site stores and shall provide appropriate (shared) site office accommodation and welfare facilities. These facilities shall be made available to EirGrid if required. Any temporary designs associated with the temporary storage are subject to the SI No 299/2007 Safety, Health and Welfare at Work regulations.

Laydown and amenity areas shall be within the red-line boundary as shown in the planning permission drawings but outside the existing substation fence.

Once the Works are made live, the Customer shall ensure that their laydown areas/welfare facilities are located outside the substation compound fences.

The Customer shall provide their own temporary LV power supplies for construction and testing purposes.

5.4 COMMISSIONING

EirGrid will arrange a pre-commissioning handover meeting between the Customer and the ESB Networks Commissioning team following completion of the Customer's pre-commissioning of the substation.

5.4.1 SUPPORTING ROLE

The Customer shall provide suitably qualified assistance as required to the ESB Networks commissioner to facilitate the efficient commissioning of the station.

Any construction work in the station required during the commissioning stage shall be carried out under the control of the ESB Networks commissioner or PICW as agreed at handover meeting.

The Customer shall continue to carry out the role of PSCS during the commissioning phase unless otherwise agreed.

5.4.2 COMMISSIONING TESTING

The Customer shall be responsible for arranging all necessary pre-commissioning activities intended to confirm the operational readiness of the Project, or individual elements thereof, and to demonstrate that it meets the Functional / Operational Specification requirements issued by EirGrid.

Results and records of all such activities shall be in such a form as may be included in the Health & Safety File.

Where any pre-commissioning may involve connections to existing Transmission infrastructure, then such works shall be conducted in accordance with ESB Networks "Electrical Safety Rules 2006".

Final commissioning shall only be carried out by personnel appointed by ESB Networks for the specific project. For contestable works, this commissioning shall be arranged via EirGrid.

Any issues identified by the ESB Networks appointed commissioner will be logged in a Commissioning snag list. It is the responsibility of the Customer to rectify all issues identified on this list that has been relayed by the EirGrid Client Engineer.

5.5 TELEMESS REQUIREMENTS

The connection of new apparatus * of the substation to the existing transmission system shall be carefully considered, sequenced and a plan submitted to EirGrid and ESB Networks with due regards to ESB Telemess procedures.

Customers shall be familiar with ESB Telemess procedures to ensure correct sequencing of work activities to prevent potential restrictive interface protocols being introduced during commissioning works in the de-energised substation.

The Customer shall provide a suitably authorised PICW 7000 operator for telemessing (issue of request for disconnection, issue of Proof of Partial Readiness, receipt of proof of disconnection) as required.

5.6 COMPLETION / HANDOVER

The principal document required at Project Completion / Handover is the completed Health & Safety File, required under the Safety, Health & Welfare at Work (Construction) Regulations 2013 [S.I. 291 of 2013].

The Customer shall ensure that a suitable Health & Safety File is prepared by the Project Supervisor Design Process (PSDP) and that the file meets the requirements of Regulation 13, specifically:

* Sections 4.11 and 4.12 of the ESB Blue Book safety rules 2006 outline the criteria for when to treat new apparatus as part of the system and when not to treat new apparatus as part of the system respectively.

13. The project supervisor for the design process shall—

(a) prepare a written safety file appropriate to the characteristics of the project, containing relevant safety and health information, including any information provided under *Regulation 21*, to be taken into account during any subsequent construction work following completion of the project, and

(b) promptly deliver the safety file to the client on completion of the project.

6 CUSTOMER INTERFACE REQUIREMENTS

6.1 PHYSICAL INTERFACE

The HV substation shall be built on one site with a fence separating the EirGrid substation compound from any adjacent Customer substation compound. Each compound shall be separately accessible via its own access gates.

A common substation access road may connect to both the transmission substation and customer compound roads providing that the requirement for unrestricted 24/7 access to the EirGrid compound, per section 3.2.1, is not affected.

Where overhead HV conductor crosses the dividing substation compound fence, all clearances as listed in this specification, shall be maintained.

6.2 CIVIL INTERFACE

The terrace and drainage works of both transmission and Customer compounds shall be designed to prevent excess water run-off from one compound into the other. Terrace levels on both sides of the separation fence shall be the same.

Further details of civil requirements are outlined in EirGrid functional specification XDS-GFS-13-1001 and the contestable works package or Committed Project Parameters.

6.3 HIGH VOLTAGE INTERFACE

The High voltage interface (including connection points and ownership boundaries) shall be assessed on a case by case basis and outlined in the Connection Agreement.

Refer to “Contestability of Connection Assets”, October 16th 2007, section 2.3, available on EirGrid’s website at this address: <http://www.eirgridgroup.com/site-files/library/EirGrid/Contestability-paper-Oct-2007.pdf>

6.4 LOW VOLTAGE INTERFACE

An interface kiosk shall be provided in the palisade fence separating the EirGrid compound from the Customer compound. This kiosk shall be accessible via a lockable door on the EirGrid and on the Customer sides. The interface signals between EirGrid and the Customer shall be marshalled in this kiosk via isolating links, to enable signal testing and safe installation.

Please refer to the following documents for further information:

- EirGrid functional specification XDS-GFS-06-001: 110/220/400 kV Control, Protection and Metering.
- EirGrid functional specification XDS-GFS-07-001: Substation Control and Protection Cabinets and Marshalling Kiosks.
- EirGrid functional specification XDS-GFS-08-001: Station Auxiliary Power Supplies
- EirGrid Wired Interface schematics XDN-ELS-STND-H-006, 007, 009 and 0011 as part of Contestable Works Package.
- EirGrid Policy Statement 13: Access to TSO Current and Voltage Instrument Transformer Cores.

7 QUALITY ASSURANCE

This section outlines the Quality assurance requirements which shall be met by the customer.

Further guidance can be found in EirGrid document “Getting Connected, Delivery Phase of Contestable Projects” which is provided at project kick off or by request to info@eirgrid.com.

Communication and all documents shall be in English.

7.1 CUSTOMER’S RESPONSIBILITY

In the first instance the Customer shall ensure that all designs and drawings are prepared by a competent Designer(s) appointed in line with the requirements of the Safety, Health and Welfare (Construction) Regulations 2013. Additionally all designs and drawings shall be submitted in their native format and in .pdf versions to EirGrid for review against the Functional Specifications prior to the commencement of any ordering or construction.

In advance of submitting planning permission, the customer should engage with EirGrid to ensure that all elements relating to the EirGrid functional specifications have been considered as part of the planning application.

Notwithstanding any review by EirGrid of any information submitted by the Customer the Customer’s obligations shall not be relieved, absolved or otherwise modified and EirGrid shall have no liability whatsoever in relation to its review comments or lack of review comments in respect of any designs or information submitted to it by the Customer.

The customer shall demonstrate that the design, construction, testing and installation of any asset connecting to the high voltage transmission system is safe by design and residual risks are sufficiently identified to allow for the safe energisation, operation, maintenance and alteration of the asset.

The Customer shall be responsible for ensuring adequate Quality Control of all manufacturers, suppliers, contractors and sub-contractors. A description of the Quality Control philosophy of the customer shall be provided.

The Customer shall ensure that all comments raised during design review and construction monitoring process (further outlined below) are addressed to the satisfaction of the EirGrid Client Engineer.

The Customer should be aware that an EirGrid internal stage gate review process is in place to ensure that projects are designed and constructed in accordance with the required specifications and standards.

This review process establishes key milestones whereby a project can progress through the various phases when certain criteria are met. These milestones and the subsequent dependencies are summarised in Table 6.

Table 6: Summary of EirGrid stage gate review

Gate	Milestone	Dependency
SGR/01	Contestable design review complete	Begin Construction
SGR/02	Construction Works complete	Begin pre-commissioning
SGR/03	Pre-commissioning complete	Begin commissioning
SGR/04	Commissioning complete	Energisation & handover

7.1.1 DESIGN REVIEW AND CONSTRUCTION MONITORING COMMENTS LOGS

Any omissions, issues and/or non-compliances identified by EirGrid Client Engineers and ESB Networks Due-diligence Engineers during the Design Review and Construction phase will be logged in Design Review and Construction Monitoring Comments logs.

All such items shall be addressed and rectified by the Customer in revised designs submission and / or remedied at site. In any event all issues shall be closed before handover of the assets.

Customer shall use the latest templates of comments logs which will be included in the contestable works package.

7.2 SUBMISSIONS

7.2.1 GENERAL

All designs shall be submitted for EirGrid review in line with the specifications issued. Designs reviewed by EirGrid shall not be altered without written agreement.

Complete design packages which are in compliance with the design submission programme must be submitted. Incomplete or poor quality design packages will not be reviewed and the design review phase will be placed on-hold until a complete package of high quality is received.

A sample design submission has been provided in the appendices for reference.

Technical schedules are key indicators of acceptability of design and should be prioritised in terms of submission schedules.

Relevant test reports are a key design requirement and should also be prioritised in the design submissions.

All symbols used in electrical drawings shall be in accordance with IEC Publication 60617 and the SI system of units shall be used throughout.

All designs and drawings shall be complete, accurate, and geographically correct. The designs and drawings shall be sufficiently detailed to enable construction and installation to proceed without further need for additional drawings or documentation.

All documentation submitted shall be suitably identified and labelled by means of title blocks, page numbers and revision status.

All drawings and documents must demonstrate that a quality assurance process has been implemented.

The Customer shall provide further details of their Quality Assurance process if requested by EirGrid, however the process shall ensure the validation of designs is carried out by competent persons who is independent of the person producing the design.

As a minimum all documents shall have a producer, checker/ verifier and approver, where:

Producer: The producer is responsible for producing a drawing/document which is technically correct, in accordance with the appropriate standards and specifications and which is clear and concise. The producer shall check the document for correctness before submitting it for verification.

Checker / Verifier: The role of the verifier is to carry out a complete independent check of all aspects of the document/drawing.

Approver: The role of the approver is to ensure that the functions of the producer and verifier have been administered correctly in accordance with the appropriate procedures. The approver shall have an in-depth knowledge of the quality management procedures for their particular area. The approver must also be satisfied that the document/drawing etc. is fit for release. Note: The verifier shall not be the approver.

Electronic filenames are not to be excessively long (maximum 26 characters) and shall contain document number and revision only. Filenames shall be alpha-numeric only i.e. shall not contain reserved characters such as "&, -, #, !, ^ etc.

The method of electronic file sharing must be agreed between EirGrid and the Customer at an early stage in the project.

All documentation submitted for review shall be accompanied by a document Transmittal sheet using the EirGrid transmittal template. The latest version of this template shall be included in the contestable works package.

7.2.2 DESIGN REVIEW

EirGrid will issue comments on the design review submissions via the design review comments log (generally within 3 weeks of receipt*). The format of this document is not to be altered by the Customer and the customer should respond to the comment log in the field provided.

The design review for each element must be carried out prior to construction commencing.

EirGrid's review of the customer design submissions is not intended to be an approval and the customer is responsible for ensuring that the design is in compliance with the EirGrid functional specifications.

7.2.3 DRAWINGS

All drawings shall be on international A4, A3, A2, A1 or A0 size sheets. A4 shall be used as far as possible and A3 as the next preferred size. Where the subject matter cannot be accommodated to a good standard on the smaller sizes the next sizes A2 etc. shall be used.

Drawings of A0 and A1 size shall be reduced to A2 size for hardcopy submission.

7.2.4 TECHNICAL DOCUMENTS AND CAD

All technical documents (e.g. drawings, instruction manuals, etc.) shall also be provided in electronic format. Manuals and drawings shall be provided in accordance with the following minimum format requirements:

Adobe Reader*.PDF

- AutoCAD *.DWG compatible with AutoCAD 2015

Information shall also be provided in additional native file formats if requested by EirGrid. Some examples are below, the Customer shall also confirm software version used:

- .DXF

* One complete design submission package can be facilitated per 3 business week period.

- .DGN
- .XML
- .KMZ (Google Earth)
- .BAK (PLS CADD)
- .DOC
- .XLS
- .f05 (CDEGS)
- .PFD (PowerFactory)
- .RAW/.SAV/.DYR/.OBJ (PSSE)

7.2.5 SITE DOCUMENT FILE

The Customer shall maintain at the construction site a Site Document File incorporating all changes and modifications as they occur. The file shall include a Drawing/Document List, a Master Drawing File and a Master Technical Instruction File.

7.2.6 OPERATION AND MAINTENANCE INSTRUCTION MANUALS

Operation and Maintenance Instructions shall be prepared in the form of an instruction manual for use by relevant parties and EirGrid personnel.

Electronic draft copies shall be submitted to EirGrid three months before erection of equipment commences.

Two hard copies of all operation and maintenance manuals plus the pre-commissioning “as-built” documentation shall be provided to EirGrid at least two weeks prior to the commissioner commencing on site.

This documentation shall also be provided in electronic format to EirGrid.

Following commissioning and energisation the commissioning “as-built” documentation shall be returned to the Customer to prepare the final “as-built” records.

A complete electronic set of final “as built” operation and maintenance manuals along with all required drawings shall be submitted to EirGrid within three months of the substation being taken over or put into service.

7.2.7 DOCUMENTATION TO BE SUBMITTED UPON PROJECT INITIATION

The following shall be submitted:

- Lists of applicable standards and codes.
- Outline Organisation Chart.
- Site conditions/ survey data.
- Design assumptions/criteria.
- Initial Design Risk Assessment (DRA). This is expected to be updated as the design phase of the project progresses.
- Scope of Work.
- Details of Persons responsible for the designs, including details of holders of legal roles (PSDP, PSCS etc.).
- Outline Works Programme/Project Programme for each section of the works including the design submission phase.
- Submittals list detailing all submissions including submission dates.
- Reference lists as required by the sub clause on Service Experience.

A description of the Quality Control philosophy of the customer, manufacturers and suppliers as well as proposals for Quality Control and Quality Assurance such as sampling techniques, statistical parameter, and tests carried out on raw materials employed.

- Training Plan.
- Deviations from Specification, quoting relevant clause numbers of this specification.

7.2.8 BEFORE MAJOR EQUIPMENT ORDERS

Technical schedules and supporting documentation shall be submitted before major equipment orders are placed.

The Major equipment shall include, but not be limited to: all outdoor HV equipment, control and protection schemes, batteries and chargers.

The Technical Schedules for the relevant items of plant set out the particular technical requirements of the equipment. The Customer shall submit a fully completed copy of the Technical Schedules for EirGrid review and acceptance in advance of equipment ordering. All associated calculations and studies in support of the proposed equipment (e.g. CT suitability or conductor forces calculations) shall be submitted at the same time as the Technical Schedules.

The following shall also be submitted:

- A list of all the major equipment to be ordered for the project. This list shall include information on the equipment such as: equipment description, equipment type, supplier's details, expected delivery date on site.
- The Customer must support all technical data "offered" with supporting design information, technical data sheets, general arrangement drawings, test reports and all supplementary information as necessary for each piece of major equipment.
- Deviations from specification, quoting relevant clause numbers of the specification shall be clearly identified in the associated Technical Schedule.
- A detailed manufacturing and factory acceptance test programme, covering all the equipment. EirGrid shall be advised of any divergence from the submitted programme immediately on occurrence.
- Details of routine tests to which all equipment will be submitted before dispatch.
- Warrantee details of each piece of equipment shall be provided in line with the respective warranty requirements of the relevant plant.
- All other information necessary for a full understanding and evaluation of the substation equipment shall be included.

Where derogations are being sought, the formal Derogation Request shall be submitted prior to ordering equipment (section 8.4 refers).

7.2.9 BEFORE THE DELIVERY OF EQUIPMENT

Four weeks prior to the delivery of the equipment, the technical record folder shall be supplied in hardcopy (3 copies) and softcopy for each type and voltage rating.

This folder shall include:

- Detailed physical and electrical drawings.
- Declaration of hazardous materials and safety data sheets. (Including all documentation required under REACH regulation; Chemical Safety Report, assessment of Exposure Scenarios etc.)
- Detailed installation, operation and maintenance instructions.
- Certificates relating to the insulating medium.
- Summary of type tests, routine tests and special tests, with copies of the test reports.
- Full technical particulars, detailed electrical connection diagram including internal wiring, detailed physical drawings, technical literature, photographs and recommended spare parts.

7.2.10 BEFORE COMMENCEMENT OF CONSTRUCTION

All substation design shall be submitted in electronic format prior to commencement of construction on site. The following non-exhaustive list shall apply:

- Proposals for Site Documentation File.
- Design for the civil and building works, including design calculations and layout drawings of the yard and building works.
- Design for the earthing and lightning protection works, including calculations, layout drawings, Grid Potential rise contours, lightning shielding profiles.
- Design for the High Voltage works, including design calculations, single line diagrams, layout drawings, general arrangements, and elevations.
- List of substation labels, and layout drawings indication position of the labels.
- Design for the control and protection works, including calculations, schematic drawings, and connection diagrams.
- Designs for the station auxiliary works (including batteries), to include calculations, schematics and drawings.
- Site test and commissioning plan, detailing test on plant and equipment to be conducted on site.
- All other information necessary for a full understanding and review of the design.

Further details relating to the submission and maintenance of the Customer's quality plan can be found in EirGrid document XDS-SDM-00-001 Safe by design methodology.

7.2.11 BEFORE EQUIPMENT ERECTION COMMENCES

Draft Operation and maintenance manuals to be submitted to EirGrid.

7.2.12 BEFORE COMMISSIONING

The Customer is required to submit a protection settings request with all supporting documentation for all protection relays at least 10 weeks prior to commencement of commissioning works. This request shall be submitted to the project Client Engineer with all information provided as included in the Protection Settings template contained in the Contestable Work Pack.

Prior to hand over of the works for commissioning, the Customer shall carry out and issue all test reports associated with the pre-commissioning tests in accordance with EirGrid Pre-commissioning requirements XDS-GFS-20-001. (Any outstanding works not completed at the time of hand over shall be listed in the pre-commissioning files and communicated during the pre-commissioning handover meeting).

The Customer shall also issue the following documentation in accordance with the Construction Regulations for EirGrid and ESB Networks review:

- Site safety file* (including all risk assessment associated with the O & M of all equipment)
- As-built drawings of the substation and equipment as supplied and installed;
- All pre-commissioning documents;
- Any other relevant documentation deemed necessary for the long term operation and maintenance of the substation.

It should be noted that failure to provide the required information in full may delay commissioning and energisation.

7.2.13 BEFORE HANDOVER TO EIRGRID

Two copies of the final as-built drawings of the substation layout and equipment as supplied and installed.

* An up to date version of the Safety File, including any required updates identified during commissioning, shall be available on site ahead of energisation.

8 GENERAL REQUIREMENTS

8.1 GENERAL TECHNICAL REQUIREMENTS

8.1.1 OIL AND GAS

Unless otherwise specified, sufficient oil or gas shall be supplied to fill all equipment provided under this specification. The oil and gas shall be of appropriate type, shall meet all Irish and European legislative requirements and shall be suitable in all respects for use in the equipment, when it is operated under the conditions laid down in this specification.

8.1.2 PREVENTION OF ACIDITY

The design, and all materials and processes used in the construction of the equipment, shall be such as to reduce the risk of development of acidity in the oil or gas to a minimum.

8.1.3 CORONA AND RADIO INTERFERENCE

All equipment shall be designed so as to minimise corona or electrical discharge and radio interference. Limit values for individual items of plant are outlined in the relevant EirGrid Functional Specification.

8.1.4 CORROSION

Individual functional specifications define surface treatment of metals for particular items of equipment.

The painting of all electrical and control equipment shall be of the highest quality and take into account the atmospheric conditions where the equipment will be located. Unless otherwise stated, painting systems used shall be suitable for long duration (> 15 years) in a C5-M environment as per EN ISO 12944.

Appropriate controlled conditions shall be implemented by the Contractor when carrying out repair or touch-up works to any painted surface on site.

8.1.5 WELDING

Where possible, onsite welding of HV equipment and support structures should be avoided.

Where this cannot be achieved, welding of proprietary items, including switchgear enclosures and busbars, shall be carried out in accordance with an approved standard or code of practice. The welding plants and processes used shall be suited to the materials, configurations and purposes of the welded parts.

Only qualified welders, certified for the type of welding required, shall be employed. The Customer shall exercise strict control over the welding conditions and parameters and shall continuously monitor the standard of welding achieved in accordance with the requirements of the Clause on Quality Control and Quality Assurance, to the satisfaction of EirGrid.

The Customer shall also ensure that anti-corrosion measures are applied to ensure that the final assembly meets the requirements of the associated functional specification.

8.1.6 ELECTROMAGNETIC COMPATIBILITY

The equipment shall conform to Standards IEC 60204-1, IEC 61000-6-2 and IEC 61000-6-4. High voltage and electronic equipment supplied shall be designed such that it does not cause mal-operation of any other equipment.

The Customer's design shall eliminate electromagnetic interference from lightning strikes to the building or to equipment installed outside of the building. The Customer shall detail measures taken to eliminate electromagnetic interference to control equipment or to low level control circuits from power cables or from power switching devices.

8.2 TOOLS, ACCESSORIES AND SPARE PARTS

The Customer shall provide all tools, accessories and spare parts in accordance with the relevant equipment functional specifications in addition to those listed in Technical Schedule XDS-GTS-00-001.

The Customer shall submit details of all tools and accessories recommended for correct operation and maintenance for a 40 year expected lifetime of the substation.

The Customer shall guarantee the continuing availability (for a minimum of 15 years, or greater if required by individual specifications) of the complete range of spare parts for the equipment offered. The spares shall be delivered prior to putting the Works into service. All spares provided shall be listed in the safety file with their location stated.

Any special tools required for operation or maintenance of the equipment shall also be listed by the Customer in the relevant technical schedule.

The Customer shall confirm with EirGrid the list of required tools, accessories and spare parts on a project basis.

All tools, accessories and spare parts shall be packaged, delivered and stored in accordance with manufacturer's recommendations. Parts shall be treated and packed to ensure safe transport and a long shelf life without deterioration. Each packing shall be clearly and indelibly marked with its contents.

Parts which are subject to deterioration due to atmospheric pollution, humidity or condensation shall be fully sealed and further protected by packs of suitable environmentally safe desiccant.

The Customer shall provide secure and lockable storage in each substation for spare parts of equipment, operating handles for outdoor equipment, portable earthing equipment, tools and all other loose equipment.

Proposals for storage shall be submitted to EirGrid for review. These proposals shall include dimensioned drawings of the proposed storage device(s), its location and proposed labelling/identification arrangements for the tools/accessories.

The tools, accessories and spare parts shall be delivered prior to putting the substation into service and shall be listed in the safety file with their location stated. Particular attention to be paid to items with “use by” dates.

8.3 WARRANTY

Warranties for all equipment shall be provided in accordance with the respective Connection Agreement and various EirGrid functional specifications.

The following minimum periods shall apply where no specific requirements are outlined:

- General: 24 months from commissioning up to 36 months from delivery to site.
- Corrosion: 5 years from first energisation up to 6 years from delivery to site.

The Customer shall transfer all warranties to the transmission asset owner at the time of asset transfer.

The attendance of specialist personnel to resolve problems with the equipment’s operation will be required within a maximum period of 7 calendar days.

All defects notified within the above periods shall be rectified entirely at the Customer’s expense, including the cost of transporting faulty equipment to and from site.

Should any design fault become apparent to the Customer / Manufacture or EirGrid after the expiry of the above periods and during the equipment’s life time, the Customer / Manufacture shall deliver all components necessary to correct the fault, together with all necessary instructions and specialist assistance, free of charge.

The Customer shall guarantee the continuing availability (for a minimum of 15 years) of the complete range of spare parts for the equipment offered.

8.4 COMPLIANCE WITH SPECIFICATION

All deviations from the requirements of this (or any) specification shall be listed in the schedule of Deviations from Specification (part of TECHNICAL SCHEDULES).

Where deviations are proposed in the design the Customer shall also submit a formal Derogation Request outlining an explanation of why the non-compliance is expected and any additional information to support the request for EirGrid to consider. Further information is outlined in EirGrid’s Derogation Process Guidance document XDS-GGD-00-001.

8.5 INSTALLATION

The equipment shall be installed in accordance with the manufacturer's instructions. These instructions shall be clear and shall be specific to the equipment being supplied. They shall cover all aspects of equipment installation up to and including putting into service.

All work shall be open to inspection by EirGrid.

8.6 SERVICE EXPERIENCE

The Customer shall supply details of the proposed location of manufacture of all plant, indicating the number of the particular plant type being offered that has been manufactured at that particular location.

The Customer shall also include a reference list of locations and clients to whom the specific plant type being offered has already been supplied. The plant type being offered shall have a minimum of a five year proven service record.

8.7 SIGNS, LABELS AND RATING PLATES

The EirGrid standard nomenclature shall apply as outlined in the project specific Single Line Diagram. *

Labels and nameplates shall be provided to clearly identify the function and circuit designation and phase of each item of HV and LV equipment.

All switchgear bays and all cabinets shall be labelled front and back and at each operating position. All withdrawable equipment including detachable doors/panels shall be labelled both on the withdrawable item and on the fixed part with which it mates.

All rating plates, nameplates, labels and wiring plates shall be of non-corrosive material. Where etched labels are proposed, clear perspex covers shall be provided to prevent dust accumulation obscuring inscription text. Inscriptions shall be clearly legible from the operating distance and shall be in English throughout.

In general, all labels shall be screw fixed. Labels shall not be fitted to removable items, e.g. trunking covers.

8.7.1 SUBSTATION SIGNS AND NOTICES

The substation shall be fitted out with notices and signs as required by the latest revision of the Safety, Health and Welfare at Work (General Application) Regulations.

In general, all signs and notices shall be bolted or screw fixed. Cable ties are not acceptable.

* Further details can be found in EirGrid document "Transmission Plant Designation and Naming Standards".

8.7.2 RATING PLATES

Each item of equipment shall be provided with manufacturer fitted rating plate listing the type and serial number together with its ratings and service conditions and any other information required by the relevant functional specification and IEC recommendations.

The rating plates installed on plant shall be legible by personnel viewing plant at ground level.

8.7.3 NAME PLATES

Name plates shall be provided and fitted throughout the substation to identify the equipment, circuit/bay name, and phase designation of HV and LV equipment.

Association with a particular section of busbar shall be indicated on the label, e.g. Busbar A1 Disconnecter. Circuit titles shall be as shown on the substation single line diagrams.

All cabinets and mechanism boxes shall be labelled front and back. This label shall include the highest voltage present in the cabinet. All withdrawable and detachable items and equipment shall be labelled both on the withdrawable / detachable part as well as the fixed part to which it attaches or mates.

A list of proposed substation labels shall be submitted to EirGrid for review. The location of the labels shall be indicated on the substation layout design drawings submitted to EirGrid for review.

Examples of name plates for AIS substation labels are listed in the latest revision of the EirGrid standard drawing XDN-LAB-STND-001 and name plates for GIS stations in specification XDS-GFS-25-001.

8.8 TESTS

8.8.1 TEST AND INSPECTION PLAN

Customer shall submit for the review of the EirGrid a Test and Inspection Plan for all items of the Works whether at the site or elsewhere up to the date of certification of completion.

Such plan shall be in two parts covering factory tests and site tests respectively.

The plan shall include as a minimum:

- a description of the item or part of the Works to be inspected or tested.
- the nature and frequency of the inspection and testing.
- the type and size of samples to be taken (if any).
- the means of recording the test and inspection data.
- the name and specific responsibilities of any proposed test and inspection agency.
- all other information necessary to describe the test or inspection to be performed.

8.8.2 FACTORY TESTS AND TYPE TESTS

Type test certificates must be provided for all equipment as set out in the equipment specifications. These tests shall have been carried out at an independent testing station or alternatively shall have been witnessed by a representative of an independent testing agency or other independent witness.

Full details of any modifications (no matter how minor) which have been made to the design or manufacturing process since the full set of type tests were carried out shall be submitted for review together with the reports on the tests which were carried out to prove the modification. The acceptance of any proposed equipment may be made conditional on further tests being performed.

Routine tests shall be performed on all equipment as set out in the equipment specifications.

A test proposal shall be submitted by the customer for any equipment or systems for which type tests are not available. This would be applicable to systems which are made up of separate equipment such as control and protection panels etc.

EirGrid shall be notified by the customer of all factory tests 2 weeks prior to the factory test taking place, and shall reserve the right to attend any or all of these tests.

No equipment shall be dispatched to site prior to satisfactory review of the test results by EirGrid.

8.8.3 DELIVERY

The Customer shall ensure that a delivery monitor is used for equipment susceptible to internal damage from mechanical shock and that these monitors are mounted in locations such that they are visible without opening the packaging. The Customer shall provide assurance to EirGrid, that the equipment has not experienced excessive shocks during transportation to its installed position.

The Customer shall be responsible for the off-loading of all material (including power transformers) on site and storage of material in a secure area, including free-issue material. Off-loading of material shall be planned and sequenced to suit the size of the site. Security will be required if material cannot be housed indoors.

The Customer shall inspect all material deliveries for compliance with the relevant designs and functional specifications in advance of inspection, including free-issue material. This inspection will also include inspection for defects within 1 day of delivery and report any findings to the EirGrid.

The Customer shall ensure that damage to any public or private roads or footpaths used by any vehicles or plant proceeding to or from the site shall be kept to a minimum. The Customer shall be responsible for the cost of all repairs necessary to restore such roads or footpaths to their original condition.

8.8.4 TESTS ON COMPLETION

In the case of contestable connections, final commissioning tests will be arranged by EirGrid. The Customer shall provide any necessary assistance for this work.

Prior to handing over of the Works or any section of the Works, the Customer shall carry out Tests on Completion in accordance with the provisions of this and the pre-commissioning specification. Such tests shall be carried out at the Customer's risk.

The tests shall be carried out in the presence of EirGrid and to their satisfaction.

8.9 TRAINING

The Customer shall submit a Training Plan which shall describe in detail how the Customer proposes to train ESB and EirGrid staff.

Separate training shall be made available for the ESB (Asset Owner) and EirGrid (System Operator) staff.

8.9.1 ESB TRAINING

A training plan shall be provided at least 8 weeks before the training course and at least 4 weeks before the commissioning of the plant.

The courses shall cover plant familiarisation, fault diagnosis and testing and all aspects of plant maintenance. Training instructors shall be knowledgeable and experienced in the manufacture, erection, testing and maintenance of the equipment and shall have good communications skills in the English language.

The training shall also be provided on site during the construction period.

Training day(s) in the completed substation shall be required to cover items such as:

- Fire & Intruder alarms systems
- Fire suppressant systems
- AIS / GIS operation
- SCS familiarisation
- Gas monitoring operations
- Plant familiarisation
- Fault diagnosis and testing
- Plant maintenance
- Plant Safety (earthing, isolation, lockout-tagout procedure)
- Cable jointing of any new high voltage cable and cable accessories

8.9.2 EIRGRID TRAINING

Training courses shall cover plant familiarisation, fault diagnosis and testing and all aspects of plant maintenance. Training instructors shall be knowledgeable and experienced in the manufacture, erection, testing and maintenance of the equipment and shall have good communications skills in the English language.

The training shall also be provided on site during the construction period.

Training day(s) in the completed substation shall be required to cover items such as:

- Fire & Intruder alarms systems
- Fire suppressant systems
- AIS / GIS operation
- SCS familiarisation
- Gas monitoring operations
- Plant familiarisation
- Fault diagnosis and testing
- Plant maintenance

8.10 RESPONSIBILITY FOR FACILITIES AND SUFFICIENCY OF MEANS EMPLOYED

The Customer shall make his own arrangements with the relevant supply authorities for all necessary supplies of electricity, water, gas, telephone etc. required for construction and testing and shall pay all installation and running costs charged by the authorities. Where such supplies are not available for any reason, the Customer shall make provision for adequate site supplies as may be necessary for the installation and testing of the Works.

The Customer shall also provide at his expense all necessary machinery, lifting equipment, oil or gas treatment equipment, tools, scaffolding, etc. required for construction. All such equipment shall be maintained throughout the project in good working order.

The customer shall take upon himself the full and entire responsibility for the sufficiency of tools and equipment and generally for all means used for the fulfilment of the project, whether or not such means may have been approved of, recommended by, or commented on by EirGrid.

8.11 EQUIPMENT ON LOAN

Where items of equipment or tools are received on loan from EirGrid or other authority they shall be returned, in the same condition in which they were received, as soon as practicable following use. A receipt shall be completed and signed by the authority concerned. A copy of this receipt shall be forwarded to EirGrid. If this procedure is not adhered to, the Customer may be held responsible for loss or damage to the equipment.

The Customer shall be fully responsible for ascertaining the suitability and serviceability of equipment on loan, and the use of this equipment shall be entirely at the Customers risk.

8.12 CONTROL OF SITE

The Customer shall be responsible for the security of the site on 24 hour basis until such time that the responsibility for substation security be transferred to EirGrid. Details of the Customer's security proposals shall be submitted to EirGrid for approval.

EirGrid shall be allowed access to the Works as required for EirGrid to satisfy itself as to the quality of the work.

8.13 WORK PREPARED OFF SITE

The Customer shall give to EirGrid written notice of the preparation or manufacture, at a place not on the site, of any manufactured material or component to be used on the Works stating the place and time of the preparation or manufacture, so that EirGrid may inspect it at all stages of the work and not only when the material or component is completed. Any material or component which is prepared or manufactured without such notice having been given may be rejected if EirGrid considers that its' inspection was necessary during the process or the preparation or manufacture.

8.14 CARE OF THE WORKS

The Customer will be held responsible for the care of the works generally until their completion, including all work executed and materials deposited on the site by himself or by Sub-Contractors and suppliers.

8.15 SLIPS

The Customer shall make good any damage or defect caused by slips to any cuttings, excavations or embankments and shall do all necessary work to prevent or remedy the same, to the satisfaction of EirGrid.

8.16 SUPPORT OF WORKS AND ADJACENT STRUCTURES

The Customer shall, at his own expense, supply and erect to the approval of EirGrid all supports as may be required to protect efficiently all structures or works requiring support as a result of the work and shall remove same on completion. Such protection shall be afforded to EirGrid property and to third party property.

8.17 CO-OPERATION WITH OTHER CONTRACTORS

The Customer shall co-operate with other Contractors in the design and programming of areas of interface. When such designs have been finalised, they shall be submitted for to EirGrid for review. The Customer shall also co-operate fully with other Contractors during the period of site works on the substation and all work on site shall be carried out in such a manner as to cause minimum interference to the work of other Contractors.

All work on-site carried out by other Contractors shall be co-ordinated by the Project Supervisor Construction Stage for the site.

Interface meetings shall be held as necessary and minutes recorded by the customer to agree interface plans. Details of the interfaces with third parties and interfaces with other projects shall be developed in advance of construction phase.

9 APPENDIX

Proposal of Design submission packs	
Programme	Overall project schedule
	Design submission schedule
Preliminary Design	SLD
	Initial design assumptions / RFI / Derogation request
	Substation layout
	Indicative Cable/OHL route
	Initial Design Risk Assessment
	Interfaces to existing transmission network
	Safety File structure
Initial Civil design	Soil Investigation
	Flood risk assessment
	Environmental management
	Structural calculations
	Building layouts
	Drainage (surface and foul)
Substation layout	Plan elevation & section drawings
	Access/egress and electrical clearances
	DWA assessment
	Conductors & connectors
	Support structures
	Forces calculations (static & dynamic)
HV Plant	Product details (physical & electrical)
	Technical schedules
	Insulation co-ordination study
	Circuit Breaker suitability
	CT & VT suitability
	Factory Acceptance Test schedule
Earthing & Lightning	Soil assessment
	Earthing studies
	Earth grid design
	Lightning assessment
	Lightning Protection system design
	Components & technical schedules
Civil construction design	Access & roads
	Bunds bases & plinths
	Ducting & trenches
	Control buildings detail
	Ventilation & pressure calculations (battery & GIS)
	Gates, Fences & railings
	Drainage (surface & foul water)
	Reinstatement
	Certification/dispensation (disabled access, fire, BCAR etc)
Secondary electrical	Protection & Control schematics
	Control room layout
	Panel/Enclosure details

	Multicore cable schedule (block diagram) (trench/duct adequacy)
	Generator & House Transformers
	Auxiliary loading & battery sizing calculations
	Auxiliary supply & distribution (a.c. & d.c. systems)
	Lighting & general services
	Fire & Security systems
	Communications & inter-tripping (F/O network)
	Metering
	Customer interface
	Signals & alarms
	Interlocking
	Cables
Trench profiles (incl. duct & backfilling details)	
Details of joint bays	
Cable materials & Technical schedules (HV & fibre)	
Cable thermal rating calculations	
Screen bonding and sheath voltage assessment	
Joints & Terminations	
Factory Acceptance Test schedule	
OHL	Route detail
	Tower/poleset types heights & locations
	Ground stability
	Foundation design
	Conductor, insulators & accessories
	Shieldwire detail
	Conductor phasing & transposition details
	Jumpers
	Materials details & Technical Schedules
	Clearances & sag calculations (PLSCADD)
	Short circuit forces
	Conductor & accessories ratings
Pre-commissioning	Checklists & test results
	Pre-commissioning Technical schedule
	Marked up (red line) documents
	Draft Safety File (including all equipment O&M manuals)
Handover	Handover certificate
	As Built drawings
	Final Safety file