



All-Island Ten Year

Transmission Forecast
Statement **2016**



DISCLAIMER

EirGrid and SONI have followed accepted practice in the collection and analysis of data available. While all reasonable care has been taken in the preparation of this statement, EirGrid and SONI/NIE Networks are not responsible for any loss that may be attributed to the use of this information. Prior to taking business decisions, interested parties are advised to seek separate and independent opinion in relation to the matters covered by this statement and should not rely solely upon data and information contained herein. Information in this document does not amount to a recommendation in respect of any possible investment. This document does not purport to contain all the information that a prospective investor or participant in the Single Electricity Market may need. Furthermore, all interested parties are strongly advised to channel any enquiries through EirGrid and SONI.

This document incorporates the Transmission System Capacity Statement for Northern Ireland and the Transmission Forecast Statement for Ireland.

For queries relating to this document or to request a copy contact enquiries@soni.ltd.uk or info@eirgrid.com.

COPYRIGHT NOTICE

All rights reserved. This entire publication is subject to the laws of copyright. This publication may not be reproduced or transmitted in any form or by any means, electronic or manual, including photocopying without the prior written permission of EirGrid and SONI.

©SONI Ltd 2017
12 Manse Rd, Belfast, BT6 9RT, N. Ireland

©EirGrid Plc 2017
The Oval, 160 Shelbourne Road, Ballsbridge, Dublin 4, Ireland



Foreword

EirGrid and SONI, as the transmission system operators (TSOs) for Ireland and Northern Ireland respectively, have collaborated to produce the latest all-island Ten Year Transmission Forecast Statement (TYTFS).

This 2016 statement has been prepared in accordance with the provisions of Section 38 of the Electricity Regulation Act, 1999 (EirGrid) and Condition 33 of SONI's Transmission System Operator licence.

The TYTFS 2016 presents the most up-to-date available transmission system information at the data freeze date of July 2016.

The statement shows that data centres now represent significant demand connections in Ireland. Based on customer enquiries, a large portion of these centres plan to connect in the Dublin area. If they connect as predicted, new large scale generation, transmission solutions, demand side response and/or storage will be required in the Dublin area to accommodate further demand increases and ensure continued security of supply.

The opportunities shown to connect new demand in Northern Ireland are dependent on the completion of the planned North – South 400 kV tie line. This planned development will increase security of supply on the island. It will also support the development of renewable power generation and provide economic benefits to customers on the island.

The results presented in the TYTFS 2016 highlight new generation opportunities in the East of the island, and in particular in the East of Northern Ireland. The results also show that to allow future generation connections in the North-West, West and South-West regions, network reinforcements would be required.

Those who are considering connecting generation or demand to the transmission systems of Ireland or Northern Ireland should contact us at info@eirgrid.com or enquiries@soni.ltd.uk.

I hope you find this document informative and we welcome any feedback and suggestions.



Fintan Slye
Chief Executive, EirGrid Group



Robin McCormick
General Manager, SONI and Executive Director
Operations, Planning & Innovation, EirGrid Group



All-Island Ten Year

**Transmission Forecast
Statement** **2016**

Document Structure

Document Structure

This document contains an Abbreviations and Terms section, an Executive Summary, eight main sections and eight appendices. The structure of the document is as follows:

The **Abbreviations and Terms** provides a list of abbreviations and terms used in the document.

The **Executive Summary** gives an overview of the main highlights of the document.

Chapter 1: Introduction: presents the purpose and context of the All-Island Transmission Forecast Statement. Our statutory and legal obligations are also introduced.

Chapter 2: The Electricity Transmission System: describes the existing all-island transmission system. A brief outline of transmission system development plans for both Ireland and Northern Ireland is also given.

Chapter 3: Demand: describes the demand forecast assumptions over the study period of 2016 – 2025.

Chapter 4: Generation: describes the projected generation connection assumptions over the study period of 2016 – 2025.

Chapter 5: Transmission System Performance: provides information on power flow and short circuit study results.

Chapter 6: Overview of Transmission System Capability Analysis: outlines the analysis methods used to carry out the demand and generation opportunities' analyses.

Chapter 7: Transmission System Capability for New Generation: describes the opportunities for connection of new generation on the all-island transmission system.

Chapter 8: Transmission System Capability for New Demand: describes the opportunities for connection of new demand on the all-island transmission system.

Appendix A: Maps and Schematic Diagrams

Appendix B: Transmission System Characteristics

Appendix C: Demand Forecasts at Individual Transmission Interface Stations

Appendix D: Generation Capacity and Dispatch Details

Appendix E: Short Circuit Currents

Appendix F: Additional Information on Opportunities

Appendix G: References

Appendix H: Power Flow Diagrams



All-Island Ten Year

Transmission Forecast
Statement **2016**

Abbreviations and Terms

Abbreviations

AC	Alternating Current
ACS	Average Cold Spell
ATR	Associated Transmission Reinforcement
BETTA	The British Electricity Trading and Transmission Arrangements
BSP	Bulk Supply Point
CAES	Compressed Air Energy Storage
CCGT	Combined Cycle Gas Turbine
CER	Commission for Energy Regulation
CHP	Combined Heat and Power
DC	Direct Current / Double Circuit
DCCAE	Department of Communications, Climate Action and Environment
DfE	Department for the Economy
DO	Distillate Oil
DSM	Demand Side Management
DSO	Distribution System Operator
EIDAC	EirGrid Interconnector DAC
ESB	Electricity Supply Board
ESRI	Economic and Social Research Institute
EU	European Union
FAQ	Firm Access Quantity
GCS	Generation Capacity Statement
GIS	Gas Insulated Switchgear
HFO	Heavy Fuel Oil
HVDC	High Voltage Direct Current
IA	Interconnector Administrator
IME	Internal Market for Electricity
IMP	Independent Market Participant
IPP	Independent Power Producer
IRL	Ireland
ITC	Incremental Transfer Capability
kV	Kilo Volts

LFG	Land Fill Gas
MIL	Moyle Interconnector Limited
MCR	Maximum Continuous Rating
MEC	Maximum Export Capacity
MIC	Maximum Import Capacity
MVA	Megavolt-Amperes
MW	Megawatt
NI	Northern Ireland
NIE	Northern Ireland Electricity
NTC	Net Transfer Capacity
PPB	Power Procurement Business
PU	Per Unit
PST	Phase Shifting Transformer
RES	Renewable Energy Schemes
RIDP	Renewable Integration Development Project
RMS	Root Mean Square
RP	Review Period
SEM	Single Electricity Market
SONI	System Operator for Northern Ireland
SPS	Special Protection Scheme
SVC	Static Var Compensator
SP	Summer Peak
SS	Substation
SV	Summer Valley
TDP	Transmission Development Plan
TYTFS	Ten Year Transmission Forecast Statement
TRM	Transfer Reserve Margin
TSO	Transmission System Operator
TTC	Total Transfer Capacity
TX	Transformer
WFPS	Wind Farm Power Station
WP	Winter Peak

Terms

Active Power	The product of voltage and the in-phase component of alternating current measured in Megawatts (MW). When compounded with the flow of 'reactive power', measured in Megavolt-Amperes Reactive (Mvar), the resultant is measured in Megavolt-Amperes (MVA).
Autumn Peak	This is the maximum Northern Ireland demand in the period September to October inclusive.
Associated Transmission Reinforcement	Associated Transmission Reinforcements (ATRs) are all of the transmission reinforcements that must be completed in order for a generator to be allocated FAQ. ATRs include reinforcements such as line and busbar upratings, new stations and new lines.
Bulk Supply Point	A point at which the Northern Ireland transmission system is connected to the distribution system.
Busbar	The common connection point of two or more circuits.
Capacitor	An item of plant normally utilised on the electrical network to supply reactive power to loads (generally locally) and thereby supporting the local area voltage.
Commission for Energy Regulation	The Commission for Energy Regulation (CER) is the regulator for the electricity, natural gas and public water sectors in Ireland.
Circuit	An element of the transmission system that carries electrical power.
Combined Cycle Gas Turbine	A collection of gas turbines and steam units; waste heat from the gas turbine(s) is passed through a heat recovery boiler to generate steam for the steam turbine(s).
Combined Heat and Power	A plant designed to produce both heat and electrical power from a single heat source.
Constraint	A transfer limit imposed by finite network capacity.
Contingency	The unexpected failure or outage of a system component, such as a generation unit, transmission line, transformer or other electrical element. A contingency may also include multiple components, which are related by situations leading to simultaneous component outages.
Data Freeze Date	The dates on which the Transmission Forecast Statement data was effectively "frozen" for both EirGrid and SONI. Changes to transmission system characteristics made after these dates do not feature in the analyses carried out for this Transmission Forecast Statement.
Deep Reinforcement	Refers to transmission system reinforcement additional to the shallow connection that is required to allow a new generator or demand to operate at maximum capacity.
Demand	The peak demand figures in Table 3-1 in the introduction refer to the power that must be transported from transmission system-connected generation stations to meet all customers' electricity requirements. These figures include transmission losses.

Demand-Side Management	The modification of normal demand patterns usually through the use of financial incentives.
EirGrid	EirGrid plc is the state-owned company established to take on the role and responsibilities of Transmission System Operator in Ireland as well as market operator of the wholesale trading system.
EirGrid Interconnector DAC	EIDAC is an organisation that is part of the EirGrid Group. EIDAC owns the East West Interconnector linking the electricity grids in Ireland and Wales. EIDAC sell capacity on the East West Interconnector through auctions.
Embedded Generation	Refers to generation that is connected to the distribution system or at a customer's site.
Firm Access Quantity	The level of firm financial access available in the transmission network for a generator is that generator's Firm Access Quantity or 'FAQ'. Firm financial access means that if a generator is constrained on or off, it is eligible for compensation in the manner set out in the Trading & Settlement Code.
Gate 2	The term given to the group-processing scheme that applies to approximately 1,300 MW of renewable generation seeking connection to the transmission and distribution systems.
Gate 3	The term given to the group-processing scheme that applies to approximately 5,300 MW of generation seeking connection to the transmission and distribution systems.
Generation Dispatch	The configuration of outputs from the connected generation units.
Grid Code (EirGrid)	The EirGrid Grid Code is designed to cover all material technical aspects to the operation and use of the transmission system of Ireland. The code was prepared by the TSO (pursuant to Section 33 of the Electricity Regulation Act, 1999) and approved by the CER. The Grid Code is available on www.eirgrid.com .
Grid Code (SONI)	The SONI Grid Code is designed to permit the development, maintenance and operation of an efficient, co-ordinated and economical transmission system in Northern Ireland. It is prepared by the TSO (SONI) pursuant to condition 16 of SONI's Licence. The SONI Grid Code is available at www.soni.ltd.uk .
Interconnector Administrator	An Interconnector Administrator (IA) facilitates the allocation of capacity and energy trading. Trading is carried out using an Auction Management Platform (AMP) for the Moyle and East West Interconnectors.
Incremental Transfer Capability	A measure of the transfer capability remaining in the physical transmission system for further commercial activity over and above anticipated uses.
Interconnector	The tie line, facilities and equipment that connect the transmission system of one independently supplied transmission system to that of another.
Loadflow	Study carried out to simulate the flow of power on the transmission system given a generation dispatch and system load.
Maximum Continuous Rating	<p>The maximum capacity (MVA) modified for ambient temperature conditions that the circuit can sustain indefinitely without degradation of equipment life.</p> <p>The MCR of a generator is the maximum capacity (MW) modified for ambient temperature conditions that the generation unit can sustain indefinitely without degradation of equipment life. All generation capacity figures in this Transmission Forecast Statement are maximum continuous ratings (defined as its MCR at 10°C), expressed in exported terms i.e., generation unit output less the unit's own load.</p>

Maximum Export Capacity	The maximum export value (MW) provided in accordance with the generator's connection agreement. The MECs are contract values which the generator chooses to cater for peaking under certain conditions that are not normally achievable or sustainable e.g., a CCGT plant can produce greater output at lower temperatures.
Northern Ireland Authority for Utility Regulation (UR)	UR are an independent non-ministerial government department set up to ensure the effective regulation of the Electricity, Gas and Water and Sewerage industries in Northern Ireland.
Node	Connecting point at which several circuits meet. Node and station are used interchangeably in this Transmission Forecast Statement.
Parametric Analysis (P-V) curves	A parametric study involves a series of power flows that monitor the changes in one set of power flow variables with respect to another in a systematic fashion. In this Transmission Forecast Statement the two variables are voltage and ITC.
Per Unit (p.u.)	Ratio of the actual electrical quantity to the selected base quantity. The base quantity used here for calculation of per unit impedances is 100 MVA.
Phase Shifting Transformer	An item of plant employed on the electrical network to control the flow of active power.
Power Factor	The power factor of a load is a ratio of the active power requirement to the reactive power requirement of the load.
Reactive Compensation	The process of supplying reactive power to the network.
Reactor	An item of plant employed on the electrical network to either limit short circuit levels or prevent voltage rise depending on its installation and configuration.
Shallow Connection	Shallow Connection means the local connection assets required to connect a customer to the Transmission System and which are for the specific benefit of that particular customer.
Single Electricity Market	The Single Electricity Market (SEM) is the wholesale electricity market operating in Ireland and Northern Ireland. Further information is available at http://www.sem-o.com/ and https://www.semcommittee.com/ .
SONI	System Operator for Northern Ireland (SONI) Ltd is owned by EirGrid plc. SONI ensures the safe, secure and economic operation of the high-voltage electricity system in Northern Ireland and in cooperation with EirGrid is also responsible for running the all-island wholesale market for electricity.
Split Busbar	Refers to the busbar(s) at a given substation which is operated electrically separated. Busbars are normally split to limit short circuit levels or to maintain security of supply.
Static Var Compensator	Device which provides fast and continuous capacitive and inductive reactive power supply to the power system.
Summer Valley	This is the minimum system demand. It occurs in the period March to September, inclusive in Ireland and May to August, inclusive in Northern Ireland
Summer Peak	This is the maximum system demand in the period March to September, inclusive in Ireland and May to August, inclusive in Northern Ireland.
Tee Connection	Un-switched connection into existing line between two other stations.

Total Transfer Capability	The total capacity available on cross-border circuits between Ireland and Northern Ireland for all flows, including emergency flows that occur after a contingency in either system.
Transformer	An item of equipment connecting busbars at different nominal voltages. (see also Phase Shifting Transformer)
Transmission Interface Station	A station that is a point of connection between the transmission system and the distribution system or directly-connected customers.
Transmission Losses	A small proportion of energy is lost mainly as heat whilst transporting electricity on the transmission system. These are known as transmission losses. As the amount of energy transmitted increases, losses also increase.
Transmission Peak	The peak demand that is transported on the transmission system. The transmission peak includes an estimate of transmission losses.
Transmission Planning Criteria	The set of standards that the transmission system of Ireland is designed to meet.
Transmission System	The transmission system is a meshed network of high-voltage lines and cables (400 kV, 275 kV, 220 kV and 110 kV) for the transmission of bulk electricity supply around Ireland and Northern Ireland. The transmission system and network are used interchangeably in this Transmission Forecast Statement.
Upgrading	To increase the rating of a circuit. This is achieved by increasing ground clearances and/or replacing conductor, together with any changes to terminal equipment and support structures.
Winter Peak	This is the maximum annual system demand. It occurs in the period October to February, inclusive in Ireland and in the Period November to February in Northern Ireland.

All-Island Ten Year

Transmission Forecast
Statement **2016**

Table of Contents

Contents

Foreword

Document Structure

Abbreviations and Terms

Executive Summary

S-1

1. Introduction

1-1

1.1 Governing Arrangements

1-1

1.2 Grid Development Strategy

1-2

1.3 Data Management

1-3

1.4 Other Information

1-4

1.5 Publication

1-4

2. The Electricity Transmission System

2-1

2.1 Overview of the All-Island Electricity Transmission System

2-1

2.2 Existing Connections Between Ireland and Northern Ireland Transmission Systems

2-3

2.3 Interconnection with Great Britain and Europe

2-4

2.4 Ireland Transmission System Developments

2-6

2.5 Northern Ireland Transmission System Developments

2-14

2.6 Joint Ireland and Northern Ireland Approved Transmission System Developments

2-19

2.7 Connection of New Generation Stations

2-19

2.8 Connection of New Interface Stations

2-21

2.9 Detailed Transmission Network Information

2-22

3. Demand

3-1

3.1 All-Island Peak Transmission Demand

3-1

3.2 Demand Data

3-4

3.3 Forecast Demand at Transmission Interface Stations in Ireland

3-7

3.4 Northern Ireland Bulk Supply Point (BSP) Demand

3-7

4. Generation

4-1

4.1 Generation in Ireland

4-1

4.2 Generation in Northern Ireland

4-5

5. Transmission System Performance

5-1

5.1 Forecast Power Flows

5-1

5.2 Compliance with Planning Standards

5-2

5.3 Short Circuit Current Levels

5-3

6.	Overview of Transmission System Capability Analysis	6-1
6.1	All-Island Demand Opportunity Analysis	6-1
6.2	All-Island Generator Opportunity Analysis	6-6
6.3	Factors Impacting on Results	6-9
7.	Transmission System Capability for New Generation	7-1
7.1	Background	7-1
7.2	New Generation Capacity	7-1
7.3	Generation Opportunity	7-1
7.4	Generation Locational Tariff Signals and Their Impact on Transmission Network Capacity	7-3
7.5	How to Use the Information for Generation	7-6
7.6	Looking to the Future	7-7
8.	Transmission System Capability for New Demand	8-1
8.1	Transmission System Demand Capability Obligations	8-1
8.2	All-Island Transmission System Capability for New Demand	8-1
8.3	Opportunities for New Demand in the Dublin Area	8-2
8.4	Transmission System Capability for New Demand in Ireland	8-9
8.5	Controllable Demand	8-12
8.6	Transmission System Capability for New Demand in Northern Ireland	8-13
8.7	How to Use the Information for Demand	8-14
A.	Maps and Schematic Diagrams	A-1
A.1	Network Maps	A-1
A.2	Short Bus Codes	A-4
A.3	Schematic Diagrams of the All Island Transmission System	A-8
B.	Transmission System Characteristics	B-1
B.1	Characteristics of the Existing Transmission System	B-2
B.2	Transmission System Developments	B-25
C.	Demand Forecasts at Individual Transmission Interface Stations	C-1
D.	Generation Capacity and Dispatch Details	D-1
D.1	Generation Capacity Details	D-2
D.2	Generation Dispatch Details	D-19

E.	Short Circuit Currents	E-1
E.1	Background of Short Circuit Currents	E-1
E.2	The Nature of Short Circuit Currents	E-1
E.3	Duty of Circuit Breakers	E-2
E.4	Short Circuit Current Calculation Methodology	E-3
E.5	Short Circuit Currents in Ireland	E-3
E.6	Short Circuit Currents in Northern Ireland	E-40
F.	Additional Information on Opportunities	F-1
F.1	EirGrid Approach to Consultation	F-1
F.2	SONI Approach to Consultation	F-1
G.	References	G-1
H.	Power Flow Diagrams	H-1
H.1	Guide to the Power Flow Diagrams	H-1

All-Island Ten Year

**Transmission Forecast
Statement** **2016**

Executive Summary

Executive Summary

The All-Island Ten Year Transmission Forecast Statement (TYTFS) 2016 provides the following information:

- Network models and data of the All-Island transmission system;
- Forecast generation capacity and demand growth;
- Maximum and minimum fault levels at transmission system stations;
- Predicted transmission system power flows at different points in time; and
- Demand and generation opportunities on the transmission system.

The TYTFS 2016 is prepared in accordance with the statutory regulations outlined in Table S-1.

Table S-1: Statutory Regulations requiring the TSOs to produce a Transmission Forecast Statement

Ireland	Northern Ireland
Section 38 of the Electricity Regulation Act 1999 (as amended)	Condition 33 of the Licence to participate in the Transmission of Electricity

The TYTFS 2016 describes the transmission system on the island of Ireland from 2016-2025. EirGrid and SONI have jointly prepared the TYTFS 2016. This document supersedes the All-Island Transmission Forecast Statement 2015-2024.

This document presents the most up-to-date information available for the all-island transmission system at the data freeze date, 01 July 2016. Where applicable we provide information on transmission system projects under development¹. Where multiple solutions are presented for a transmission system project, no particular preference is given to one solution².

The demand forecast used in our analyses represents an average annual increase in winter peak demand of 0.5% between 2016 and 2025³. This demand forecast is taken from the [All-Island Generation Capacity Statement 2016-2025](#) (GCS)⁴. There has recently been an increase in activity in the demand sector. Additional information is included in this document because of considerable interest and enquiries for data centre connections to the grid. If these connections materialise, new large scale generation, transmission solutions, demand side response and/or storage will be required in the Dublin area to accommodate further demand increases and ensure continued security of supply.

The all-island renewable generation capacity is expected to increase rapidly up to 2020; reaching approximately 7,000 megawatts (MW) of generation capacity. In this TYTFS onshore wind contributes to the majority of renewable generation. However, there has recently been a significant increase in solar generation applications⁵. Some large conventional plants are expected to retire/divest from 2016-2025, a total capacity of 1,354 MW.

TYTFS 2016 includes maximum and minimum short circuit current levels⁶ at transmission system stations. This information is given at each 110 kilovolt (kV), 220 kV, 275 kV and 400 kV transmission system station. Short circuit levels at each transmission system station are given for the following years: 2016; 2019; and 2022.

1. This information is in accordance with EirGrid's Grid Development Strategy, available at the following link: <http://www.eirgridgroup.com/the-grid/irelands-strategy/>
 2. In line with our strategy to consider all practical technology options for network development.
 3. http://www.eirgridgroup.com/site-files/library/EirGrid/Generation_Capacity_Statement_20162025_FINAL.pdf
 4. The TYTFS 2016 references documents that were published at the July 2016 data freeze date. The All-Island Generation Capacity Statement 2017-2026 is due to be published shortly. The information in the 2017 GCS however does not fundamentally impact studies presented in the 2016 TYTFS.
 5. See Chapter 4 for more information on the increase in solar generation applications.
 6. Further information on short circuit currents levels is given in Chapter 5 and Appendix E.

Results show that several stations on the island are approaching, or have the potential to exceed, their rated short circuit current level. This can be seen in the maximum short circuit current level analysis, when there are high generation levels on the system. We manage the transmission system to mitigate possible risks while investment plans are in place to resolve these issues. Information on short circuit current levels is presented in Chapter 5.

Interconnection with neighbouring countries:

- Enhances the security of supply of the transmission system; and
- Allows greater competition and the potential for prices to be reduced.

This is mainly because interconnection gives the transmission system access to a wider generation base.

Our analyses include the Moyle and EWIC high voltage direct current (HVDC) interconnectors. These interconnectors connect the all-island transmission system to the Great Britain transmission system.

The generation adequacy of Northern Ireland is dependent on the completion of the planned North – South 400 kV tie line. Our analyses assume this reinforcement is in place in Winter 2020. The results of the analyses performed for TYTFS 2016, post 2020, are therefore dependent on the North South reinforcement being commissioned. The planned North – South 400 kV tie line will increase security of supply on the island. It will also support the development of renewable power generation and provide economic benefits to customers on the island. Information on the North - South 400 kV tie line is presented in Chapter 2.

TYTFS 2016 includes information on generation and demand opportunities for interested parties. This information is based on assessments and studies carried out on an all-island basis. The methodologies applied to the all-island opportunity analyses are presented in Chapter 6. Information on opportunities is presented in Chapter 7 and Chapter 8.

The all-island generation opportunities assessment in Chapter 7 provides information for generators wishing to connect to the transmission system. Generator opportunity is provided at a number of 110 kV, 220 kV, 275 kV and 400 kV modes across the all-island transmission system, determined using an incremental transfer capability analysis. The results show little to no opportunity for new generation in the North and West of the island. Towards the large demand centres in the East, there is capacity for additional generation. Additionally, due to the potential development of large data centres in the Dublin area which is highlighted more in Chapter 8, there will be increased opportunities for generation close to the Dublin area.

Regional changes in locational tariff signals are also described in Chapter 7. This information is provided to help network users make informed decisions when exploring potential transmission network connection locations. Regions with surplus generation capacity in the South West, West and North West of Ireland have lower Transmission Loss Adjustment Factors and higher generator transmission use of system charges than Eastern regions with higher demand levels and less surplus generation.

All-island demand opportunities were also calculated using an incremental transfer capability analysis. The results, based on the 2021 transmission system, are presented in Chapter 8. The study indicates that all stations studied across the island have the capability to accommodate demand connections, some to a lesser degree than others. This analysis assumes that the planned North-South 400 kV tie-line is in place by 2021. This tie-line improves the generation adequacy situation in Northern Ireland. It is also an important factor when considering the capacity of the system to connect significant amounts of additional demand in Northern Ireland.

Chapter 8 also includes a qualitative assessment of the demand capability in the Dublin area. This assessment has been included as a result of the recent large volume of data centre enquires in the Dublin area. The Dublin area assessment provides:

- A description of the Dublin transmission network
- Areas of focus for demand connections in Dublin and the scale of interest in each zone
- Planned transmission developments in Dublin

The results of demand and generation opportunity analysis are based on high level transmission network assessments. The results provide guidance, the actual connection capacity and possible connection solutions can only be determined following detailed individual connection studies. We will continue to examine innovative solutions and technologies in response to future connection enquiries.

Those who are considering connecting generation or demand to the transmission systems of Ireland or Northern Ireland should contact us. It is advisable to consult us early in the project process. In Ireland customers can contact us at info@eirgrid.com while Northern Ireland customers can contact us at enquiries@soni.ltd.uk for further information.



All-Island Ten Year

**Transmission Forecast
Statement** **2016**

1. Introduction

1. Introduction

The transmission system is a network of 400 kV, 275 kV, 220 kV and 110 kV high-voltage lines and cables. It is the backbone of the power system, efficiently delivering large amounts of power from where it is generated to where it is needed.

EirGrid is the Transmission System Operator (TSO) in Ireland, while SONI is the TSO in Northern Ireland. As TSOs, we jointly prepare and publish the All-Island Ten Year Transmission Forecast Statement (TYTFS) each year.

EirGrid plan and develop¹ the transmission system in Ireland to ensure it meets forecast transmission system operating conditions. SONI is responsible for planning and operating the transmission system in Northern Ireland within defined security standards.

The TYTFS 2016 provides information on:

- Planned network developments;
- Electricity demand growth;
- Generation capacity; and
- Interconnection with other electricity transmission systems.

The appendices provide further information and transmission system data to enable the reader to perform power flow analysis. When using data provided in the TYTFS 2016², readers should consider other documents we produce including the [All-Island Generation Capacity Statement 2016-2025](#) (GCS). The GCS assesses the generation adequacy of the island of Ireland from 2016 to 2025. Where possible the TYTFS 2016 complements the demand information presented in the GCS.

EirGrid publish a Transmission Development Plan (TDP) for Ireland each year. The TDP provides details of the transmission system developments expected to be progressed in Ireland in the coming 10 years. The most recent TDP (2016-2025) was recently consulted on by the Commission for Energy Regulation (CER). The final version will be published following CER approval.

1.1 Governing Arrangements

1.1.1 Roles and Responsibilities (Governance)

Northern Ireland

Under our licence in Northern Ireland, held by SONI, we are required to plan³ and operate the Northern Ireland Transmission System.

In doing so we must comply with both the SONI Transmission System Security and Planning Standards (TSSPS) and the SONI Grid Code.

Ireland

Under our licence in Ireland, held by EirGrid, we are required to operate, develop and ensure the maintenance of the Irish Transmission System.

In doing so we must comply with both the EirGrid TSSPS and the EirGrid Grid Code.

1. EirGrid recently published an updated Grid Development Strategy for the long-term development of the network.
2. TYTFS 2016 references documents published at the July 2016 data freeze date. These and all our publications are available at www.eirgridgroup.com
3. Under the direction of the Utility Regulator (NI), investment planning functions are now the responsibility of SONI as of May 2014 (ref: Commission Decisions 12.4.2013 pursuant to Article 3(1) of Regulation (EC) No 714/2009 and Article 10(6) of Directive 2009/72/EC – United Kingdom (Northern Ireland) – SONI / NIE).

1.1.2 Duty to Prepare a Statement

EirGrid and SONI are each required to publish a Transmission Forecast Statement in line with the Statutory Regulations in Table 1-1. Since 2012 we have jointly prepared and produced an all-island document, following an agreement with the Regulatory Authorities in Ireland⁴ and Northern Ireland⁵.

Table 1-1: Statutory Regulations requiring the TSOs to produce a Transmission Forecast Statement

Ireland	Northern Ireland
Section 38 of the Electricity Regulation Act 1999 (as amended)	Condition 33 of the Licence to participate in the Transmission of Electricity

TYTFS 2016 has been prepared in accordance with and in fulfilment of these obligations. The format was approved by the Commission for Energy Regulation (CER) and the Utility Regulator (UR).

1.1.3 Single Electricity Market

A Single Electricity Market (SEM) has been operating on the island of Ireland, since 2007. The all-island wholesale electricity market allows customers in both Ireland and Northern Ireland to benefit from increased competition. This in turn allows customers to benefit from reduced energy costs and improved reliability of supply.

The model of the SEM is due to change considerably to take account of the requirements of the European Network Codes⁶ and the Target Model⁷. The new market design will be called the Integrated - Single Electricity Market (I-SEM⁸).

The transmission systems of Ireland and Northern Ireland are electrically connected by means of a 275 kV tie-line. This tie-line connects Louth station in Co. Louth (Irl) to Tandragee station, in Co. Armagh (NI).

There are also two 110 kV connections between Ireland and Northern Ireland:

- Letterkenny station in Co. Donegal (Irl) and Strabane station in Co. Tyrone (NI); and
- Corraclassy station in Co. Cavan (Irl) and Enniskillen station in Co. Fermanagh (NI).

Generation on the transmission systems of Ireland and Northern Ireland are dispatched on an all-island basis. The TYTFS transmission network models are also dispatched in this manner, to reflect how the all-island transmission system is operated.

1.2 Grid Development Strategy

EirGrid recently published an updated Grid Development Strategy⁹ (GDS). The GDS documents our strategy for the long-term development of the network and involves:

- Open engagement and inclusive consultation with local communities and stakeholders will be central to our approach to network development;
- Consideration of all practical technology options for network development; and
- Optimisation of the network to minimise requirements for new infrastructure.

The GDS aims to achieve a balance between the costs and impact of new infrastructure, while maximising the capability of the existing network.

4. The Commission for Energy Regulation is the Electricity Regulatory Authority in Ireland.
 5. The Utility Regulator is the Regulatory Authority in Northern Ireland.
 6. <https://www.entsoe.eu/major-projects/network-code-development/Pages/default.aspx>
 7. <https://www.entsoe.eu/about-entso-e/market/long-term-market-design/Pages/default.aspx>
 8. Further information on the I-SEM is available on <http://www.sem-o.com/jsem/Pages/Home.aspx>,
 9. <http://www.eirgridgroup.com/the-grid/irelands-strategy/>

1.3 Data Management

Transmission system development is continuously evolving. A data freeze date of 01 July 2016 applies to TYTFS 2016, with all information correct at that date. All data for system model files, and sequence data for use with short circuit current level analysis, was collected on this date. A data freeze date enables us to:

- Perform analyses;
- Update system models; and
- Update the appendices of TYTFS 2016.

Since the data freeze, a number of changes in the following areas have emerged. The capital approval (CP) numbers enable readers to cross reference transmission projects in Ireland with the TDP.

The following transmission system developments have been initiated as projects:

- CP0919 Lanesboro 110 kV Station Busbar Uprate
- CP0927 Clonee 220 kV Station Project
- CP0932 Coomataggart 110 kV Shallow Works
- CP0987 Snugborough 110 kV Station
- CP0970 Cross-Shannon 400 kV Cable
- CP0972 Wexford 110 kV Busbar Uprate
- CP0973 Knockraha 220 kV Station Short Circuit Works
- CP0991 Kelvin Power Shallow Works
- CP0995 Clonee 220 kV Station Phase 2
- CP0997 Cruiserath 110 kV Station
- CP0998 Dunstown 400 kV Station

The expected completion date of the following transmission system developments have shifted out by one year or more:

- CP0466 North South 400 kV Interconnector
- CP0755 Cauteen – Killonan 110 kV Circuit Uprate
- CP0756 Cauteen – Tipperary 110 kV Circuit Uprate
- CP0763 Clashavoon – Tarbert 220 kV Line Uprate
- CP0734 Cathaleen’s Fall 110 kV Station Busbar Uprate (final transfers)
- CP0825 Oldstreet – Woodland 400 kV Line Refurbishment

The following transmission system developments have been terminated as projects:

- N/A

The following transmission system developments have been completed:

- CP0500 Knockanure 220/110 kV Station
- CP0603 Clogher 110 kV Station and Associated Works
- CP0650 Ballyvouskil 220/110 kV Station
- CP0849 Cashla 110 kV Station – replace two Circuit Breakers
- CP0859 Cloghran – Corduff 110 kV Cable Reinforcement
- CP0881 Galway 110 kV Station – replace two Circuit Breakers
- CP0847 Arva – Shankill No. 1 110 kV Line Uprate

- Tamnamore Main 275 kV Substation - Phase 2
- Dungannon – Omagh 110 kV Circuits
- Coleraine – Kells 110 kV Line Uprate
- Knock Main
- Tremoge 110 kV Cluster
- Rasharkin 110 kV Cluster
- Castlereagh – Rosebank 110 kV Cable Uprate

The following transmission system developments are under review:

- CP0865 Cashla – Salthill 110 kV Line Uprate
- CP0871 Galway 110 kV Station Busbar Uprate

1.4 Other Information

Potential users of the transmission system should also be aware of the following key documents:

- SONI Grid Code¹⁰
- EirGrid Grid Code¹¹
- SONI Transmission System Security and Planning Standards¹²
- The Electricity Safety, Quality and Continuity Regulations¹³ (Northern Ireland) 2012
- EirGrid Transmission System Security and Planning Standards¹⁴
- EirGrid Operating Security Standards¹⁵
- SONI Transmission Connection Charging Methodology Statement¹⁶
- EirGrid Transmission Connection Charging Methodology Statement 2008¹⁷
- EirGrid Statement of Charges 2016/2017¹⁸
- Statement Of Charges – For Use of Northern Ireland Electricity Ltd Transmission system¹⁹
- All-Island Generation Capacity Statement 2016-2025²⁰

1.5 Publication

The TYTFS 2016 is available in pdf format on our websites:

- www.eirgridgroup.com and
- <http://www.soni.ltd.uk/>

For a hard-copy version, please send a request to info@eirgrid.com or enquiries@soni.ltd.uk.

Transmission system model files are also available on both websites.

-
10. <http://www.soni.ltd.uk/Operations/GridCodes/>
 11. <http://www.eirgridgroup.com/site-files/library/EirGrid/GridCodeVersion6.pdf>
 12. <http://www.soni.ltd.uk/media/documents/Projects/Publications/Northern%20ireland%20TSSPS%20-%20September%202015.pdf>
 13. http://www.legislation.gov.uk/nisr/2012/381/pdfs/nisr_20120381_en.pdf
 14. <http://www.eirgridgroup.com/site-files/library/EirGrid/EirGrid-Transmission-System-Security-and-Planning-Standards-TSSPS-Final-May-2016-APPROVED.pdf>
 15. <http://www.eirgridgroup.com/site-files/library/EirGrid/Operating-Security-Standards-December-2011.pdf>
 16. <http://www.soni.ltd.uk/media/documents/Archive/SONI%20Charging%20Methodology%20Statement%20December%202009%20-%20Approved%2022%20December%202010.pdf>
 17. <http://www.eirgridgroup.com/site-files/library/EirGrid/Connection-Charging-Statement.pdf>
 18. http://www.eirgridgroup.com/site-files/library/EirGrid/Statement-of-Charges-16_17-Final.pdf
 19. <http://www.soni.ltd.uk/media/documents/Customers/TUOS/Final%20TUoS%20Statement%20of%20Charges%202016-17.pdf>
 20. http://www.eirgridgroup.com/site-files/library/EirGrid/Generation_Capacity_Statement_20162025_FINAL.pdf

All-Island Ten Year

Transmission Forecast
Statement **2016**

2. The Electricity Transmission System



2. The Electricity Transmission System

2.1 Overview of the All-Island Electricity Transmission System

The transmission system in Ireland and Northern Ireland plays a vital role in the supply of electricity. It provides the means to transport energy from generators to demand centres across the island.

The transmission system in Northern Ireland is operated at 275 kV and 110 kV. The transmission system in Ireland is operated at 400 kV, 220 kV and 110 kV. The two transmission systems are connected by means of one 275 kV double circuit.

That connection is from Louth station in Co. Louth (Irl) to Tandragee station in Co. Armagh (NI). There are also two 110 kV connections:

- Letterkenny station in Co. Donegal (Irl) to Strabane station in Co. Tyrone (NI); and
- Corraclassy station in Co. Cavan (Irl) to Enniskillen station in Co. Fermanagh (NI).

EirGrid and SONI together operate the transmission systems - North and South - on an all-island basis.

The 400 kV, 275 kV and 220 kV networks form the backbone of the transmission system. They have higher power carrying capacity and lower losses than the 110 kV network.

In Ireland, the 400 kV network provides a high capacity link between the Moneypoint generation station on the west coast and Dublin on the east. We are planning a new 400 kV interconnector between Ireland and Northern Ireland called the North South Interconnector. For the purposes of the 2016 TYTFS analysis it is anticipated to be installed by the end of 2020.

In Northern Ireland the 275 kV network is comprised of:

- a double circuit ring;
- a double circuit spur to Coolkeeragh Power Station; and
- a double circuit spur southwards into Co. Louth, in Ireland.

In Ireland the transmission network is comprised of single circuit lines which are interconnected to cover the wider geographical distances between stations. Typically large generation stations (greater than 100 MW) are connected to the 220 kV, 275 kV or 400 kV networks.

The 110 kV¹ circuits provide parallel paths to the 220 kV, 275 kV and 400 kV networks and is the most extensive element of the all-island transmission system, reaching into every county on the island of Ireland.

The transmission system is generally comprised of overhead lines. There are exceptions to this, such as in the city centres of Belfast, Cork and Dublin, where underground cables are used. Table 2-1 presents the total lengths of overhead lines² and cables at the different voltage levels. Revision of individual line lengths may change following completion of network development projects.

1. A number of radial 110 kV circuits in Ireland and the 110 kV lines and cables within Dublin City are operated by the Distribution System Operator (DSO). The DSO licence is held by ESB Networks. Details of the distribution network in Dublin are not included in this All-Island Transmission Forecast Statement.

2. Some lines may contain short sections of cable.

Table 2-1: Total Length of Existing Transmission System Circuits as at the Data Collection Freeze Date (July 2016)

Voltage Level (kV)	Total Circuit Lengths (km)
400	439
275	825
220	1915
110	6415

Transformers located at substations link the different voltage networks together providing paths for power flow between voltage levels. The total transformer capacity between the different voltage levels on the all-island system is presented in Table 2-2.

Table 2-2 Total Transmission System Transformer MVA Capacity as at the Data Collection Freeze Date³ (July 2016)

Voltage Levels (kV)	Capacity (MVA)	Number of transformers
400/220	3,550	7
275/220	1,200	3
275/110	3,840	16
220/110	11,424	57

2-2

Reactive compensation devices are used to improve transmission system voltages in local areas. Existing reactive devices connected to the transmission system include shunt capacitors, static var compensators (SVCs) and shunt reactors.

Capacitors and SVCs help to support local voltages in areas where low voltages may otherwise occur. Shunt reactors suppress voltages in areas where they would otherwise be too high, most likely during periods of low demand and/or high wind. Table 2-3 displays the reactive compensation on the all-island transmission system.

Table 2-3 Total Reactive Compensation⁴ as at the Data Collection Freeze Date (July 2016)

Voltage Level (kV)	Type	Capacity (Mvar)	Number of Devices
400	Line Shunt Reactor	160	2
	Voltage Source Converter Interconnector	+/- 175	1
275	Shunt Capacitor	236	4
220	Shunt Reactor	100	1
110	Static Var Compensator	90	2
	Shunt Capacitor	921	43
33	Shunt Capacitor	29	5
22	Shunt Reactor	210	7
	Shunt Capacitor	125	5
10	Shunt Capacitor	13	1

3. Transformer details are provided in Tables B-4 and B-5 in Appendix B.

4. Details of existing reactive compensation devices are provided in Table B-7 in Appendix B.

2.2 Existing Connections Between Ireland and Northern Ireland Transmission Systems

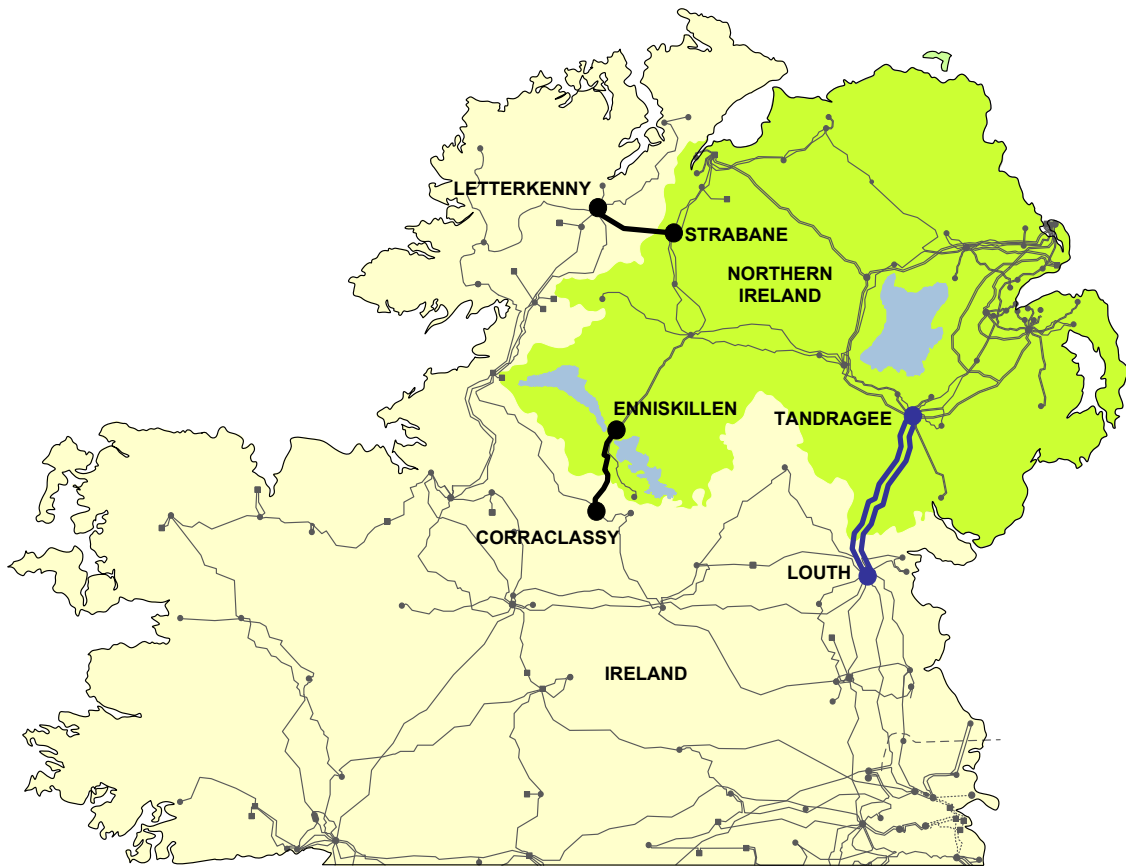

Figure 2-1 Existing Cross-Border Circuits

As illustrated in Figure 2-1, the transmission systems of Ireland and Northern Ireland are connected via a double circuit 275 kV line. This line connects the Northern Irish transmission system at Tandragee to the Irish transmission system in Louth, Ireland. There are three 275/220 kV transformers in Louth station, one 600 MVA unit and two ganged⁵ 300 MVA units.

The design capacity of each of the 275/220 kV cross-border circuits is 600MVA. However, the actual capacity of the circuits to accommodate transfers between the two systems at any time depends on the prevailing system conditions on either side of the border. This includes the ability to deal with system separation.

In addition to the main 275/220 kV double circuit, there are two 110 kV connections:

- One between Letterkenny, Co. Donegal and Strabane, Co. Tyrone; and
- One between Corraclassy, Co. Cavan and Enniskillen, Co. Fermanagh.

The purpose of these 110 kV circuits is to provide support to either system in certain system conditions. Phase shifting transformers in Strabane and Enniskillen are used to control the power flow under normal conditions.

5. Plant connected in parallel through common switchgear.

2.3 Interconnection with Great Britain and Europe

Transmission grids are often interconnected so that energy can flow from one country to another. By linking to other transmission systems, we can:

- Increase the diversity and security of energy supplies;
- Facilitate competition in the European market; and
- Aid the transition to a low carbon energy sector by integrating renewable sources.

This helps provide a safe, secure, reliable and affordable energy supply for everybody.

The East West Interconnector links the electricity grids in Ireland and Wales, while the Moyle Interconnector links the electricity grids in Northern Ireland and Scotland.

Power can be either imported or exported on the interconnectors. Interconnector power flows have system impacts that need to be managed operationally. For example, during times of import conventional generation is displaced by these non-synchronous power sources. This reduces the all-island system inertia⁶. Interconnector flows can also have implications for the system frequency and transmission system stability and operation. Frequency changes are faster in transmission systems with low rotational inertia, making frequency control and system operation more challenging.

The Moyle Interconnector also increases the dynamic reactive support required by the transmission system as the link does not have dynamic reactive power export capability⁷.

SONI acts as Interconnector Administrator (IA) for the East West and Moyle interconnectors.

Interconnector capacity is auctioned by the IA on behalf of EirGrid Interconnector DAC (EIDAC)⁸ and Moyle Interconnector Limited (MIL)⁹. The capacity is purchased by market participants and utilised in the Single Electricity Market (SEM) and British Electricity Trading and Transmission Arrangements (BETTA) markets. Figure 2-2 shows the location of the Moyle Interconnector and EirGrid East-West Interconnector.

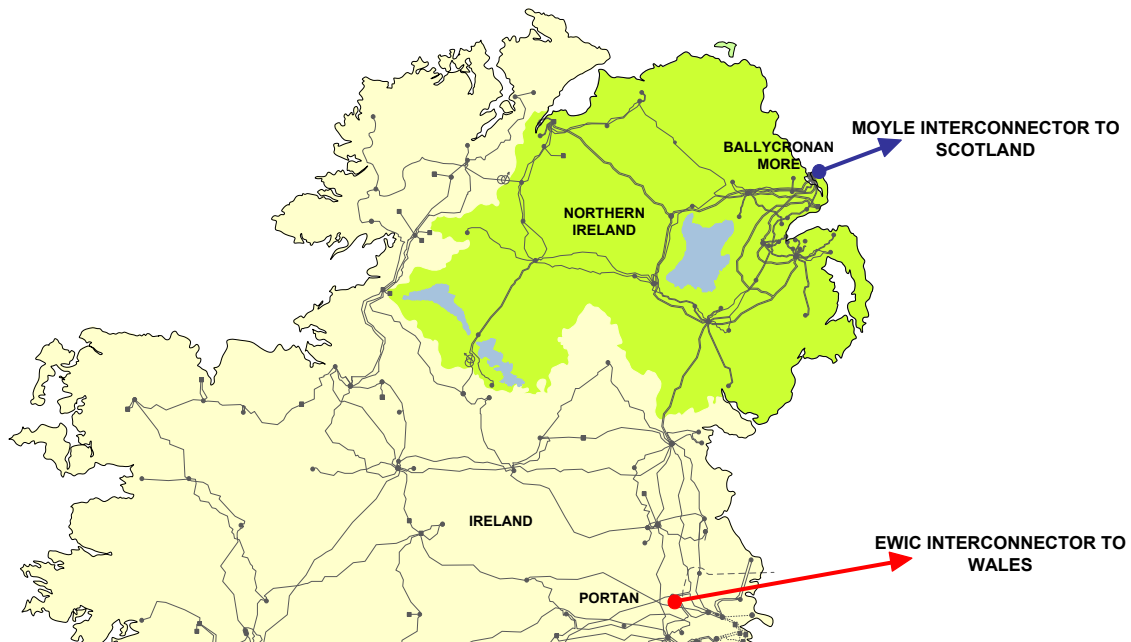

Figure 2-2 Existing Interconnectors

The amount of power that can currently be traded between Northern Ireland and Scotland across the Moyle Interconnector is detailed in Table 2-4. The Moyle interconnector capability has been restored following a lengthy outage of Pole 1 due to a cable fault.

6. System inertia is also reduced by the increased wind penetration (another form of non-synchronous generation).
 7. Unlike Moyle the East West Interconnector has dynamic reactive power export capability.
 8. <http://www.eirgridgroup.com/customer-and-industry/interconnection/>
 9. <http://www.mutual-energy.com/electricity-business/>

The amount of power that is permitted to be traded between Ireland and Wales across the East-West Interconnector is also detailed in Table 2-4. The available capacity is measured at the SEM and BETTA market reference point in Deeside 400 kV station in Wales. Table 2-4 below details the available capacity of the interconnectors.

Table 2-4 Available Capacity on Existing Interconnectors

Interconnector	Direction	Summer (MW)	Winter (MW)
Moyle	SCO – NI	410	450
	NI – SCO ¹⁰	287	295
EWIC ¹¹	WAL – IRL	530	530
	IRL – WAL	500	500

2.3.1 Moyle Interconnector

The Northern Ireland transmission system is currently connected to Scotland via a 500MW High Voltage Direct Current (HVDC) link, the Moyle Interconnector. It is a Line Commutated Converter (LCC) HVDC link, which commenced full commercial operation in 2002.

It is constructed as a dual monopole HVDC link with two coaxial sub-sea cables from Ballycronan More in Islandmagee, Northern Ireland to Auchencrosh in Ayrshire, Scotland. The link has a physical installed capacity of 500MW. An emergency flow of up to 75MW is available should the frequency on the island drop below 49.4Hz.

The converter station at Ballycronan More is looped into one of the 275 kV Ballylumford to Hannahstown circuits. The Moyle link is self-compensating for reactive power losses. There are 4 x 59Mvar capacitor banks at the Ballycronan More converter station with three of these capacitor banks acting as filters.

Where there are faults on the transmission system, effects are limited to a brief distortion of the HVDC 50Hz AC synchronous waveform in import mode. The rapid response means that the HVDC link can have a net stabilising effect on the transmission system in the event of generation loss.

Following a period where only half of the Moyle interconnector capacity was available, due to a cable fault on Pole 1, the full interconnector capacity was restored in September 2016.

The export capacity of the Moyle Interconnector will be limited to 80MW from winter 2017 onwards. This is due to the commissioning of a large wind farm in Scotland which will use up capacity on the single circuit from Auchencrosh to Coylton.

2.3.2 East-West Interconnector

The East-West Interconnector is a 500MW HVDC link which runs between Woodland, County Meath in Ireland and Deeside in North Wales. The link comprises approximately 186km of sub-sea cable and 76km of land underground cable.

The East-West Interconnector uses Voltage Source Converter (VSC) technology. VSC technology offers independent and rapid control of active and reactive power. It does not suffer from commutation failures, and is capable of offering emergency power control in the event of low or high frequency events.

In addition, due to the VSC technology, the East-West Interconnector provides black start capability. The link can operate in either voltage control or reactive power control mode independently in both converter stations. It can supply or absorb up to 175Mvar at Portan 400 kV station which is connected directly to Woodland 400 kV station. The East-West Interconnector commenced commercial operation in December 2012.

10. The Moyle Interconnector export capacity is limited to 80MW from winter 2017 due to network limitations in Scotland.

11. Power delivered to connection point at receiving power system.

2.3.3 Future European Interconnection

We are currently working with RTE, the French TSO, on a joint project investigating the business case for an interconnector between Ireland and France. The potential connection point is expected to be in the south of the country. The main benefits of this future potential project are:

- increased market integration and competition;
- increased integration of renewable energy sources; and
- increased security of supply.

In addition, third parties are investigating further interconnection between the island of Ireland and Great Britain.

2.4 Ireland Transmission System Developments

2.4.1 Grid Development Strategy

A secure supply of electricity is essential to the economy. Our transmission system must remain stable and secure under a broad range of possible future scenarios.

We published “Your Grid, Your Views, Your Tomorrow”, a discussion paper on Ireland’s Grid Development Strategy in March 2015. This discussion paper responded to feedback received from the public over recent years. It was part of our renewed efforts to encourage more participation in our decision-making process. It also reflected an updated economic context, and our growing experience of new technologies.

The updated Grid Development Strategy “[Your Grid, Your Tomorrow¹²](#)” was published in January 2017. In drafting our updated grid development strategy, we took account of feedback received on the 2015 discussion paper. We also considered the Government’s Energy White Paper, published in December 2015. We were further guided by the Action Plan for Jobs and the IDA’s 2015-2019 strategy, which includes ambitious regional targets.

Our grid development strategy is based on all available information at the time of publication in 2017, and is an informed view of network development needs in the coming years. However, we will continue to review it on a regular basis. This is to ensure that our strategy continues to be up to date, and fit for purpose in a changing Ireland.

The United Kingdom’s June 2016 referendum on EU membership has introduced new considerations. However, most issues covered by our grid development strategy relate to Ireland only, and are unaffected. Regardless of the UK leaving the EU, there will always be many shared benefits of working closely with our nearest neighbours. We aim to maintain a strong relationship between Ireland, Northern Ireland and Great Britain on energy matters.

12. <http://www.eirgridgroup.com/the-grid/irelands-strategy/>

2.4.2 Reviewing and Improving our Public Consultation Process

Following a review of our public consultation process, we promised to improve the way we consult with the public and other stakeholders. We have produced a summary guide of our improved consultation process - [Have Your Say](#)¹³. It explains why we develop the electricity grid, and how we consult with the public and other stakeholders to get feedback on our plans.

This guide tells you what to expect from us, and what we would like from you. There is one very important principle that is at the heart of our consultation process. The earlier you get involved in our projects, the more influence you can have on them.

The new approach comprises a 6-step Framework for Grid Development that provides an “end-to-end” structure for all our grid projects. It ensures an appropriate balance between technical, economic, environmental, social and community considerations, with significant provision for stakeholder engagement at all stages. A general structure of the Framework is set out in Figure 2-3 below.

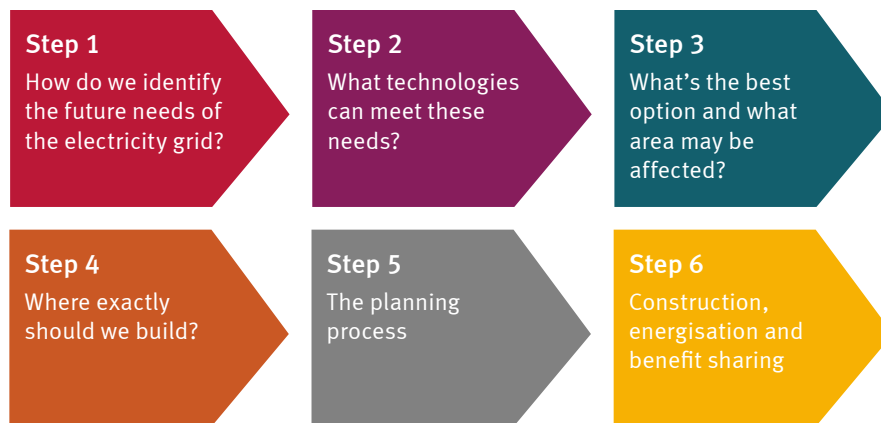

Figure 2-3 General structure of the Framework for Grid Development

2.4.3 Transmission Development Plan in Ireland

EirGrid’s Transmission Development Plan¹⁴ (TDP), details the transmission system development projects that have been initiated by us. It also discusses further developments that may arise in the period of the plan. The TDP describes projects that are required to:

- Facilitate demand growth;
- Provide new generation and demand connections¹⁵;
- Ensure the transmission system is in compliance with the Transmission System Security and Planning Standards (TSSPS)¹⁶;
- Provide interconnection capacity; and
- Refurbish or replace existing assets.

The planned transmission system developments presented in this statement are based on those projects that have received internal EirGrid approval by the data freeze date¹⁷. Appendix B outlines these developments. These projects are currently scheduled to be completed at various stages between now and 2025. It should be noted that the information presented in later chapters on transmission system transfer capabilities and opportunities is dependent on the completion of these development projects in the assumed timeframe.

Table 2-5 below shows the level of transmission system developments delivered by EirGrid (together with ESB Networks and independent contestable build contractors) that have been completed over the past six years.

13. <http://www.eirgridgroup.com/the-grid/have-your-say/>
 14. The latest TDP can be obtained from the EirGrid website <http://www.eirgridgroup.com/>
 15. For example data centres or large industrial sites.
 16. Formerly known as the Transmission Planning Criteria (TPC).
 17. July 2016

Table 2-5 Recent Historical Level of Transmission Developments

Year	Circuit Uprate (km)	New Line Build (km)	New Station Build
2010	215	37	5
2011	340	76	3
2012	215	128	2
2013	225	38	3
2014	167	79	2
2015	76	14	3

Information presented in the TDP and TYTFS documents represent a snapshot of an evolving transmission system development plan. While we are considering other reinforcements, these are not at the stage of maturity required for inclusion in this statement.

The Transmission Development Plan includes details of major transmission system developments planned for the transmission system of Ireland. Each planned development is illustrated in the maps and schematics in Appendix A. New generation connections and new transmission interface stations are described in Sections 2.7 and 2.8 respectively.

2.4.4 Project Delivery

The development of the transmission network is subject to delivery risk. We use risk management plans and processes to identify, analyse, monitor and manage project and programme risks. These plans and processes facilitate the management of project dependencies and critical path issues within the context of a changing environment.

Project completion dates in the TYTFS are forecasts based on the best project information available at the time of the data freeze date. Certainty with regard to completion dates increases as a project moves through the various phases in its lifecycle, as represented below in Figure 2-4.

The project schedule at the concept stage is developed based on standard lead times for generic project types. As a project moves forward from the concept phase a detailed schedule is developed, milestones are defined and there is therefore greater certainty regarding the completion date.



Figure 2-4 Relationship between Phases in Project Lifecycle and Completion Date Certainty

The level of certainty or risk in a project also varies by project type as shown in Figure 2-5.

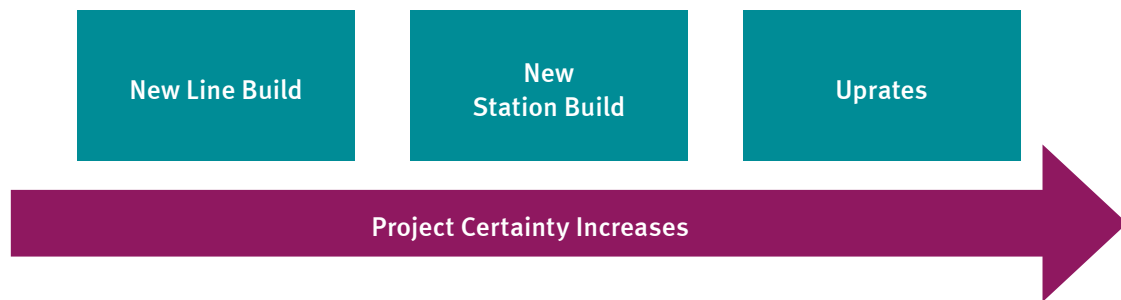

Figure 2-5 Project Certainty Depending on Project Type

We differentiate between moderate and high risk projects based on project type and project phase. Thus, line and station busbar uprate projects which are due to be completed by 2017 are considered to be within the moderate risk category. Large scale linear developments, scheduled to be completed post 2018 have a higher level of risk. Projects that are due for completion in the near-term generally carry less risk than those due for completion in later years.

The region or location of a project also has an impact on its risk profile. When interdependent projects are on-going at the same time, care has to be taken scheduling the required outages. In this case we will prioritise projects according to our prioritisation processes. This programme risk review may drive changes to the way projects are sequenced and the timing of project delivery in a region.

We review the network development programme on an on-going basis, which may result in project delivery changes for the reasons cited above. In such cases we endeavour to communicate with, and mitigate impacts on, customers.

In summary, completion dates are subject to change and the level of change typically depends on:

- The type of project;
- Phase-specific project and programme risks; and
- The region a project is in.

All developments included in this section have received internal EirGrid approval.

2.4.5 Descriptions of Ireland Development Projects

Kilpaddoge 220 kV Development¹⁸

Kilpaddoge 220 kV station, in north Co. Kerry, will be connected into the existing Clashavoon-Tarbert and Killonan-Tarbert 220 kV lines. All existing 110 kV circuits currently connecting at the existing Tarbert 220 kV station will be transferred to Kilpaddoge 220 kV station. This will make Kilpaddoge a new hub for power flows into the south-west. The Kilpaddoge 220/110 kV project is needed to replace Tarbert 220 kV station as the main transmission station in north Co. Kerry. This is because the location was restricting further access and development of the transmission station. For the purpose of the 2016 TYTFS analysis, this project is expected to be completed in 2017.

Finglas 220 kV Redevelopment

The 220 kV and 110 kV busbars in the existing Finglas 220 kV station will be reconfigured and redeveloped into a ring busbar arrangement. This project will address issues regarding the station's ability to: accommodate future load growth; security of supply to north Dublin; asset condition of existing equipment; inadequate circuit breaker ratings and the need for upgrade of the protection systems. The project will also increase operational flexibility, improve maintainability of station equipment and allow for future 220 kV expansion. For the purpose of the 2016 TYTFS analysis, this project is expected to be completed in 2018.

18. <http://www.eirgridgroup.com/the-grid/projects/north-kerry/the-project/>

Belcamp 220 kV Development¹⁹

Belcamp 220 kV station, in north Co. Dublin, will be connected to the 220 kV network by an underground cable from Finglas. A number of the existing 110 kV circuits in the area will be connected to the new Belcamp station. This development will offload demand from Finglas 220 kV station. It will also ensure compliance with the transmission and distribution system planning standards as new demand connects to the system in the North East Dublin area. For the purpose of the 2016 TYTFS analysis, this project is expected to be completed in 2018.

Knockraha 220 kV Reconfiguration

The 220 kV busbar in Knockraha 220 kV station will be reconfigured from the existing double busbar configuration to a ring busbar arrangement. The third Knockraha 220/110 kV transformer will be decommissioned resulting in the station having two 220/110 kV transformers. The project will resolve issues regarding security of supply, operational flexibility and improve maintainability of station equipment. For the purpose of the 2016 TYTFS analysis, this project is expected to be completed in 2021.

Laois-Kilkenny Reinforcement Project²⁰

A new 400/110 kV station to be located near Portlaoise, Co. Laois, with an associated 110 kV circuit to Kilkenny 110 kV station via Ballyragget station. The 400/110 kV station will be looped into the existing Moneypoint-Dunstown 400 kV line and the existing Portlaoise-Athy 110 kV line. The proposed infrastructure will improve quality of supply to the south-east. It will also increase capacity in the region. For the purpose of the 2016 TYTFS analysis, this project is expected to be completed in 2019.

Inchicore 220 kV Redevelopment

The oldest section of the existing Inchicore 220 kV station, in Co. Dublin will be replaced with a new GIS compound. This project will address issues with the condition of existing equipment, inadequate circuit breaker ratings, and the need for upgrade of the protection systems. The new GIS compound will increase operational flexibility, improve maintainability of station equipment and allow for future 220 kV expansion. For the purpose of the 2016 TYTFS analysis, this project is expected to be completed in 2022.

Aghada 220 kV Redevelopment

The 220 kV busbar in Aghada 220 kV station will be reconfigured from the existing double busbar into a 'C' configuration. The 110 kV busbar will also be updated. The project will increase security of supply, increase operational flexibility and improve maintainability of station equipment. For the purpose of the 2016 TYTFS analysis, this project is expected to be completed in 2020.

Louth Station Redevelopment

Louth station comprises three voltage levels, 275 kV, 220 kV and 110 kV. The station will undergo a major refurbishment of assets at all three voltage levels. The 110 kV busbar will be reconfigured from the existing double busbar configuration to ring busbar arrangement. For the purpose of the 2016 TYTFS analysis, this project is expected to be completed in 2020.

Moneypoint-Kilpaddoge 220 kV Circuit

There is a planned new submarine cable across the Shannon estuary from Moneypoint in Co. Clare to Kilpaddoge in north Co. Kerry. This will create a new path for power out of the Dublin-Moneypoint group of generators into the South West. It will also create a path for power out of the South West to the 400 kV network. For the purpose of the 2016 TYTFS analysis, this project is expected to be completed by 2017.

Ballyvouskill 220 kV Development

Ballyvouskill 220 kV station will be looped into the existing Clashavoon-Tarbert 220 kV line. The station will be linked to the existing Garrow 110 kV station by one new 110 kV underground cable. The Ballyvouskill 220/110 kV project is needed to accommodate renewable generation in the south-west. For the purpose of the 2016 TYTFS analysis, this project is expected to be completed by winter 2016²¹.

19. <http://www.eirgridgroup.com/the-grid/projects/dublin-north-fringe/the-project/>

20. <http://www.eirgridgroup.com/the-grid/projects/laois-kilkenny/the-project/>

21. This project was completed in 2016.

Knockanure 220 kV Development

Knockanure 220 kV station will be looped into the existing Clashavoon-Tarbert 220 kV line as well as the existing Tarbert-Trien 110 kV circuit and the existing Athea-Trien 110 kV circuit. The Knockanure 220/110 kV project is needed to accommodate renewable generation in the south-west. For the purpose of the 2016 TYTFS analysis, this project is expected to be completed by winter 2016²².

Ballynahulla 220 kV Development

Ballynahulla 220 kV station will be looped into the existing Clashavoon-Tarbert 220 kV line. The station will be linked to the existing Glenlara 110 kV station by a new 110 kV circuit. The Ballynahulla 220/110 kV project is needed to accommodate renewable generation in the south-west. For the purpose of the 2016 TYTFS analysis, this project is expected to be completed by winter 2016²³. This station was formerly known as Kishkeam but has been renamed.

Clogher 110 kV Development

Clogher 110 kV GIS station will be looped into the existing Cathaleen's Fall – Drumkeen and Cathaleen's Fall – Golagh T – Letterkenny 110 kV lines. Mulreavy and other gate 3 wind farms will connect at 110 kV into the new Clogher 110 kV station. This 110 kV transmission station is being built contestably. For the purpose of the 2016 TYTFS analysis, this project is expected to be completed in 2016²⁴.

Poolbeg 220 kV Development

Two 50 Mvar shunt reactors will be installed in Poolbeg 220 kV station, in Co. Dublin. There has been an increase in the number of cable circuits and a reduction in the usage of the conventional generation in Dublin. This has made it more difficult to control voltage during low-demand periods. These reactors will help to adequately control the voltages, reducing the operational constraint of running generators outside of merit order. For the purpose of the 2016 TYTFS analysis, the reactors are expected to be completed in 2017.

Moneypoint Redevelopment

A new 400 kV substation will replace the existing Moneypoint 400 kV substation, which will be retired. The existing Moneypoint-Oldstreet and Moneypoint-Dunstown 400 kV circuits and Moneypoint 400/220 kV transformer will be transferred to the new Moneypoint 400 kV busbar. The station will also accommodate a second 400/220 kV transformer.

The project also involves the relocation of the existing capacitor bank from the A1/B1 110 kV busbar section to the A2/B2 110 kV busbar section. The project will address 110 kV busbar capacity issues and short circuit problems, increase operational flexibility and improve maintainability of station equipment. For the purpose of the 2016 TYTFS analysis, this project is expected to be completed in 2017.

Moneypoint – Kilpaddoge – Knockanure 220 kV Development

There is a planned new 220 kV cable from Moneypoint in Co. Clare to Knockanure in north Co. Kerry, via Kilpaddoge also in north Co. Kerry. This will create a new path for power out of the South West to the existing 400 kV network. The project will comprise a submarine 220 kV cable under the Shannon and a 21 km 220 kV land cable. For the purpose of the 2016 TYTFS analysis, this project is expected to be completed in 2019.

North Connaught

The needs of this area are continually evolving. It is likely that only one of the following two projects will be required:

- Grid West Project
- North Connaught 110 kV Reinforcement

Each project is detailed below.

22. This project was completed in 2016.

23. The 220 kV busbar was energised in 2016, the 110 kV busbar is expected to be energised in 2017.

24. This project was completed in 2016.

Grid West Project²⁵

This project is under review. Confirmation of the need is required²⁶.

We conducted a comprehensive analysis on both underground and overhead solutions for the Grid West Project. We submitted a report on this analysis to the Government appointed Independent Expert Panel²⁷.

The report, based on this detailed analysis, considers three options:

- A HVDC underground cable and associated converter stations;
- A 400 kV overhead line; and
- A 220 kV overhead line which may incorporate sections of underground AC cable.

The report was published in July 2015.

Grid West would create a new path for power out of the North Mayo region to the meshed 220 kV transmission system at the existing Flagford 220 kV station.

If the need for Grid West is fully confirmed, we will consult on the information contained in the IEP report. We will do this before selecting a preferred technology type.

For the purpose of the 2016 TYTFS analysis, all three options have been studied. This reinforcement is assumed to be completed in 2019.

North Connaught 110 kV Reinforcement

This project is under review. Confirmation of the need is required²⁸. Should this project progress, an investigation of overhead and underground options utilising various technologies will be undertaken. We will consult on these options before selecting a preferred technology type.

For the purpose of the 2016 TYTFS analysis, a new circuit between Castlebar and Moy 110 kV substations is assumed. This is purely for this analysis as other options may meet the needs. 110 kV overhead line and underground cable options have been studied²⁹. It is assumed to be completed in 2022.

Regional Solution (formerly Grid Link) Project³⁰

There is a significant amount of existing, new and contracted conventional and renewable generation connected or seeking to connect in the south and south-west. As a result, the main flow of electricity in the southern half of the Irish network is from the south and south-west towards the demand centres on the east coast. This results in a risk to the security of supply in the south - eastern area of the country.

We have developed a new and innovative technical solution, referred to as the 'Regional Option'. This solution is based on technology called "series compensation" which is capable of improving the existing grid infrastructure. This will be the first time it will be deployed on the Irish transmission grid. Series compensation enables more power to flow through existing lines. Therefore, previously proposed new 400 kV overhead lines are not required. To complete this solution, a 400 kV underwater cable across the Shannon estuary is required in addition to some upgrade works to existing transmission lines.

The Regional Solution will facilitate the integration of renewable and conventional generation in the south of Ireland. It will also facilitate potential future interconnection with Great Britain or France and ensure security of supply is maintained for the south east and south midlands in Ireland.

For the purpose of the 2016 TYTFS analysis, it is assumed to be completed in 2022.

25. <http://www.eirgridgroup.com/the-grid/projects/grid-west/the-project/>

26. Based on current information and commitments we have identified a need for either Grid West or the North Connacht 110 kV reinforcement, however not both

27. <http://www.eirgridgroup.com/site-files/library/EirGrid/Summary-of-IEP-Report-Grid-West.pdf>

28. Based on current information and commitments we have identified a need for either Grid West or the North Connacht 110 kV reinforcement, however not both.

29. As this project is at an early stage of development generic models have been used in studies. As the project matures, data in future TYTFSs may be subject to change.

30. <http://www.eirgridgroup.com/the-grid/projects/grid-link/the-project/>

Castlebagot 220 kV Development³¹

Castlebagot 220 kV station, in west Co. Dublin, will be connected into the existing Inchicore-Maynooth No. 1 and No. 2 220 kV lines. A number of the existing 110 kV circuits in the area will be connected to the new Castlebagot station. This development will offload demand from Inchicore 220 kV station. It will also ensure compliance with the distribution system planning standards as new demand connects to the system in the West Dublin area. It is assumed to be completed in 2019.

North-West Project

The cross-border Renewable Integration Development Project (RIDP)³² identified that the existing network in the north west of the island is insufficient to accommodate the future wind generation in the area. The North-West project is one element of the original RIDP preferred solution. It would connect the existing Srananagh 220 kV substation to the existing Clogher 110 kV substation in Donegal.

Should the North-West Project progress, an investigation of overhead and underground options utilising various technologies will be undertaken. For the purpose of the 2016 TYTFS analysis 220 kV overhead line and underground cable options have been studied³³. It is assumed to be completed in 2022.

31. Formerly known as West Dublin 220 kV Development.

32. <http://www.eirgridgroup.com/how-the-grid-works/ridp/>

33. As this project is at an early stage of development generic models have been used in studies. As the project matures, data in future TYTFSs may be subject to change.

2.5 Northern Ireland Transmission System Developments

This section details the transmission system projects that are planned to take place in Northern Ireland over the period covered by this forecast statement. Unapproved projects have been included using provisional completion dates assessed to be appropriate at the time of the data freeze (01 July 2016). In considering this section it should be noted that:

- A number of projects have still to go through EirGrid Group/SONI governance process to secure internal approval;
- Developments are based on assumptions relating to the forecast growth of demand and generation;
- For a number of projects included, there has been a limited level of optioneering. As projects progress, greater consideration of a wider range of potential solutions may result in developments which differ from those detailed; and
- Studies have concluded that the following projects are required to address non-compliance with standards, subject to the forecast growth in demand and generation. However, further cost benefit analysis may result, in some cases, in the identification of alternative solutions or operational interventions.

2.5.1 Description of Northern Ireland Development Projects

Coleraine-Kells 110 kV Circuit

The uprating of the section of the Coleraine-Kells circuit between Kells and the connection point to the proposed Rasharkin cluster substation is presently ongoing. The wood pole section of the circuit has been restrung with high temperature conductor. The tower line section (one side of the double-circuit between Terrygowan and Kells) is being replaced with gap conductor. For the purpose of the 2016 TYTFS analysis it is expected that this work will be completed by winter 2016³⁴.

2-14

Knock Main

The replacement of the two 60 MVA transformers at Knock Main with two 90 MVA units is ongoing. For the purpose of the 2016 TYTFS this work is expected to be completed by winter 2016³⁵.

Tamnamore/Dungannon/Omagh Developments

(i) Tamnamore Main 275 kV Substation - Phase 2

The Tamnamore Phase 2 project is a further development of the Tamnamore 275/110 kV substation entailing (i) the extension of the existing 275 kV and 110 kV double busbars at Tamnamore and the connection of a second 275 kV transformer; (ii) the connection of the Dungannon-Drumnakelly and Dungannon-Creagh 110 kV circuits; (iii) the connection of Dungannon Main by two radial circuits from Tamnamore Main and (iv) the diversion of the 275 kV Magherafelt-Tandragee circuit into the substation. For the purpose of the 2016 TYTFS this work is expected to be completed by winter 2016³⁶.

(ii) Dungannon-Omagh 110 kV Circuits

Both of the Omagh-Dungannon 110 kV circuits are now diverted into Tamnamore Main. The previous Omagh-Dungannon '2' circuit, which is planned to be connected into the Tremoge cluster, connects directly into Tamnamore. The previous Omagh-Dungannon '1' circuit uses a mesh corner at Dungannon Main to connect through to Tamnamore. This design provides resilience to Dungannon Main against N-2 contingencies. For the purpose of the 2016 TYTFS this work is expected to be completed by winter 2016³⁷.

34. This work is complete.

35. This work is complete.

36. This work is complete.

37. This work is complete.

(iii) Omagh-Tamnamore New 110 kV Circuit

It is proposed to construct a new circuit from Omagh-Tamnamore 110 kV. This circuit will be approximately 57 km in length on Portal construction with Zebra conductor (with a DOT of 75°C). The circuit will also be used to connect the proposed Gort cluster substation. For the purpose of the 2016 TYTFS, the work is expected to be completed by spring 2017.

(iv) Dungannon Main refurbishment

The 110 kV mesh at Dungannon Main is currently undergoing refurbishment. All switchgear is being replaced with 40 kA equipment. For the purpose of the 2016 TYTFS this work is expected to be completed by winter 2017.

Windfarm Clusters Development

(i) Tremoge 110 kV Cluster

It is proposed to establish a 110/33 kV windfarm cluster substation at a site adjacent to the existing 110 kV Omagh – Dungannon circuit ‘2’. This circuit will supply the new cluster substation. For the purpose of the 2016 TYTFS, Tremoge cluster is expected to be complete by spring 2017³⁸.

(ii) Rasharkin 110 kV Cluster (formally Mid-Antrim)

It is proposed to establish a 110/33 kV substation at a site adjacent to the existing Coleraine-Kells 110 kV circuit. This circuit will supply the new cluster substation. For the purpose of the 2016 TYTFS, this cluster substation is expected to be complete by spring 2017³⁹.

(iii) Gort 110 kV Cluster

It is proposed to establish a 110/33 kV substation at a site adjacent to the proposed new 110 kV Omagh-Tamnamore circuit. This circuit will supply the new cluster substation. For the purpose of the 2016 TYTFS, the Gort cluster substation is expected to be complete by spring 2017.

(iv) Curraghmulkin 110/33 kV Cluster (formerly Drumquin)

It is planned to establish a new 110/33 kV cluster substation close to Drumquin village. The Curraghmulkin cluster is to be connected to the existing Enniskillen - Omagh 110 kV circuits by means of a new switching station (Omagh South) north of Dromore village. A single portal overhead line will be built from the new station to the cluster site. For the purpose of the 2016 TYTFS, this project is assumed to be complete by summer 2018.

(v) Garvagh 110 kV Cluster

It is planned to establish a 110/33 kV cluster substation near Garvagh, connected to the proposed Rasharkin cluster via a portal overhead line. For the purpose of the 2016 TYTFS, this work is assumed to be complete by winter 2019.

(vi) Newtownstewart 110 kV Cluster and Cam Cluster

Initial consideration has been given to clusters at Newtownstewart and Cam, which are located in the West of Northern Ireland. In line with the Phase 1 Alternative Connection Application and Offer Process⁴⁰, SONI and NIE Networks have decided to look at these clusters as part of Phase 2 when there is more certainty over investment in the transmission system beyond the 2020 40% renewables target. There is currently no firm transmission capacity in the West.

For TYTFS 2016, in 2023 a new 110/33 kV cluster substation near Newtownstewart is connected to the 110 kV circuits between Omagh and Strabane. In 2024 a new 110/33 kV cluster substation near Cam, Coleraine, is connected via a loop in to the existing Coolkeeragh-Coleraine 110 kV circuit.

38. This work is complete.

39. This work is complete.

40. <http://www.soni.ltd.uk/media/documents/Consultations/Alternative%20Connection%20Application%20and%20Offer%20Process%20-%20Decision%20Paper%2031052016.pdf>

(vii) Kells Wind 110 kV Cluster

It is planned to establish a 110/33 kV cluster substation near to Kells, connected to the existing Kells station via an overhead line. For the purpose of the 2016 TYTFS, this work is assumed to be complete by 2020.

Belfast North Main

A new 110/33 kV substation at Whitla Street will allow for the decommissioning of the 110/33 kV substation at Belfast Power Station West (PSW). The existing Whitla Street 33/6.6 kV substation site is being redeveloped, allowing room for a new 33 kV switchboard and pair of 90 MVA transformers. This work is ongoing; for the purpose of the 2016 TYTFS, this project is expected to be complete by winter 2016.

Donegall Main (North)

The 60 MVA transformer TxB at Donegall North is to be replaced by a new 90 MVA unit. For the purpose of the 2016 TYTFS this work is expected to be complete by summer 2017.

Castlereagh-Rosebank 110 kV Circuits

The two existing 110 kV cable circuits between Castlereagh and Rosebank substations are being replaced, increasing the rating of each circuit to a minimum of 144 MVA. For the purpose of the 2016 TYTFS, this work is expected to be complete by winter 2016⁴¹.

Omagh Main – Omagh South restrung

With the connection of Curraghmulkin cluster substation to Omagh South it will be necessary to restring the Omagh Main – Omagh South tower line with high temperature conductor. For the purpose of the 2016 TYTFS analysis, this work is assumed to be complete by summer 2019.

Compressed Air Energy Storage Scheme (CAES)

A developer has planned the construction of a Compressed Air Energy Storage facility close to Ballylumford Powerstation. For the purposes of including the scheme in the TYTFS, the connection of the plant is modelled on the assumption that it will be supplied by installing a pair of 275 kV cables from the 275 kV switchboard at Ballylumford to the CAES site. Each cable will then be connected to a transformer for direct connection to the generation/demand. For the purpose of the 2016 TYTFS, the connection is assumed to be installed and commissioned by winter 2019.

Reactive Compensation

(i) Omagh Reactive Compensation

It is planned to install reactive support at Omagh Main. For the purpose of the 2016 TYTFS, a Statcom or Statcom/Thyristor Switch Capacitor (TSC) hybrid is assumed, connected to the 110 kV bus from 2021.

(ii) Tamnamore Reactive Compensation

It is planned to install reactive support at Tamnamore. For the purpose of the 2016 TYTFS, a Statcom or Statcom/Thyristor Switch Capacitor (TSC) hybrid is assumed, connected to the 110 kV bus from 2021.

(iii) Coleraine Reactive Compensation

It is planned to install reactive support at Coleraine. For the purpose of the 2016 TYTFS, a Statcom or Statcom/Thyristor Switch Capacitor (TSC) hybrid is assumed, connected to the 110 kV bus from 2021. The existing 36Mvar Capacitor at Coleraine is to be recovered.

Airport Road Main

It is planned to construct a new 110/33 kV substation including 2 x 60 MVA transformers and a 33 kV switchboard in the Belfast Harbour Estate, close to Airport Road. The substation will be connected as a teed transformer feeder arrangement from Rosebank Main 110 kV. The substation will supply both Airport

41. This work is complete.

Road and Queens Road 33 kV substations which are to be transferred from Cregagh Main. Additionally, Ballymacarrett 33 kV substation is also to be transferred from Knock Main. For the purpose of the 2016 TYTFS, this work is assumed to be completed by winter 2019.

Ballylumford Switchgear

The existing 110 kV switchgear at Ballylumford is to be replaced with a new 110 kV GIS double busbar and the 110 kV circuits diverted accordingly. For the purpose of the 2016 TYTFS, this project is assumed to be completed by winter 2020. Currently one 275/110 kV interbus transformer at Ballylumford is operated out of service to ensure the fault level is kept within existing switchgear fault rating. After this work is complete, this restriction can be removed.

Brockaghboy 110 kV Windfarm

It is planned that the Brockaghboy windfarm will be connected to the proposed Rasharkin cluster substation via an overhead line. For the purpose of the 2016 TYTFS, this work is assumed to be complete by 2017.

Coolkeeragh-Limavady-Coleraine 110 kV Circuits

As a result of increasing growth in renewable generation there will be a need to uprate the Coolkeeragh-Limavady, Coleraine-Limavady and Coleraine-Coolkeeragh 110 kV circuits to a minimum of 185 MVA. For the purpose of the 2016 TYTFS, this work is assumed to be complete by winter 2023.

Coolkeeragh-Magherafelt 275 kV Circuits

It is planned to replace the conductor on the existing double circuit tower line. The rating of the replacement conductor will be defined as part of the redesign of the circuit. For the purpose of the 2016 TYTFS, this work is assumed to be complete by winter 2020.

Tidal Scheme

Developers are planning to establish two 100MW tidal generation schemes off the County Antrim coast close to Torr Head and Fair Head. For the purposes of including the schemes in the TYTFS (connection method is subject to change), the connection is modelled as a new 110 kV circuit from Kells to a collector station close to the coastline. For the purpose of the 2016 TYTFS, this project is assumed to be complete by 2020.

Coolkeeragh-Killymallaght-Strabane 110 kV Circuits

As a result of increasing growth in renewable generation there will be a need to uprate the Coolkeeragh-Killymallaght, Killymallaght-Strabane and Coolkeeragh-Strabane 110 kV circuits. When works are complete, the circuits will be uprated to a minimum of 185 MVA. For the purpose of the 2016 TYTFS, this work is assumed to be complete by winter 2022.

Turleenan-Tamnamore 275 kV

With the connection of Turleenan substation it will be necessary to uprate the Turleenan-Tamnamore tower line with high temperature conductor. For the purposes of the 2016 TYTFS, this work is assumed to be complete by winter 2021.

Kells-Rasharkin New 110 kV Circuit

As a result of increasing growth in renewable generation there will be a need to construct a second 110 kV circuit between Kells and the proposed Rasharkin 110/33 kV cluster substation. This circuit will require to have a minimum rating of c. 190 MVA. For the purpose of the 2016 TYTFS, this project is assumed to be complete by 2024.

Armagh Main

Due to capacity limitations on the distribution system that supplies Armagh identified by the DSO, as well as capacity limitations at Drumnakelly Main it is proposed to establish a new 110/33 kV substation to the south of Armagh city. For the purposes of the 2016 TYTFS, this project is assumed to be completed by 2024.

Castlereagh and Tandragee 110 kV Switchgear

Due to the X/R ratio at Castlereagh and Tandragee substations that is in excess of design value of the 110 kV switchgear, both substations are at risk of being in excess of max fault levels. The most prudent option to address this risk would be to replace the switchgear with uprated equipment. Other options that require consideration are an operational intervention to reduce the fault level (although would have the potential for reduced security) and assigning a higher fault rating based on engagement with the OEM or through the testing of a sample of the circuit breakers.

2.5.2 Projects Not Included in the 2016 TYFTS Analysis

A number of projects have not been included in the TYFTS analysis due to uncertainty at this time over either:

- the case of need; and/or
- scope; and/or
- timescales.

The following projects have not been included in the 2016 TYFTS analysis⁴².

(i) Circuit Development to Reinforce the West of NI

The 110 kV transmission network in the west of Northern Ireland is subject to significant powerflows for an outage of the 275 kV double circuit between Magherafelt and Coolkeeragh. Those powerflows not only cause risk of overload but also risk of excessive phase angle. To address these risks the establishment of a new transmission circuit to the west of NI from the eastern 275 kV ring is anticipated to be required. Two options have been under consideration. The first option would be the establishment of a new 275 kV circuit from Turleenan to the planned Omagh South substation (this substation is planned as part of the Curraghmulkin cluster development). This development could also form part of a future development to south Donegal. The second option would be the development of a new circuit from Magherafelt to either Coolkeeragh or to Strabane at either 275 kV or at 110 kV. Due to uncertainty over the optimal reinforcement, TYFTS 2016 does not include this development.

(ii) Castlereagh 275 kV IBTX 4

Taking account of future growth in demand, consideration is presently being given to the need for a 4th transformer at Castlereagh. However, due to the existing level of capacity and the uncertainty over the timing of the need for the additional transformer, TYFTS 2016 does not include this development.

(iii) Coolkeeragh-Trillick 110 kV Circuit

It is planned to develop a new circuit from Trillick in Co Donegal, Ireland to Coolkeeragh in Northern Ireland. This new circuit is anticipated to be the optimal reinforcement to provide for the connection of renewable generation in Co. Donegal. The proposal will be considered alongside the overall programme of developments in Northern Ireland to cater for increased renewable generation.

(iv) Ballylumford-Castlereagh 110 kV Circuit

Consideration is being given to the uprating of this circuit in conjunction with asset replacement works that are under consideration by the TAO. At present there is uncertainty over the optimal scale of uprating. In this statement, the existing ratings are applied to these circuits.

(v) Belfast Power Station

Evermore Energy are proposing a new 480 MW CCGT, to be located in Belfast Harbour Estate. The project is in the early stages of development, and no connection application had been received at the time of the freeze date. As a result, it has not been included in the analysis for this statement.

42. However these projects are under consideration and are included for information.

2.6 Joint Ireland and Northern Ireland Approved Transmission System Developments

This section includes transmission system developments which both EirGrid and SONI have identified the need for.

We are proposing a new 400 kV circuit rated at 1500 MVA which will connect Woodland 400 kV station in County Meath (Irl) and Turleenan 400/275 kV station in County Tyrone (NI). A new 400 kV station at Turleenan is required.

At present, transmission capacity between Ireland and Northern Ireland is not sufficient. Due to a lack of capacity, we must limit power flows across the border to prevent stress on the grid. The North South Interconnector would deliver a more secure and reliable electricity supply – throughout the island of Ireland. It would bring about major cost savings and address significant issues around the security of electricity supply. This is particularly the case in Northern Ireland.

A key benefit is that it would remove bottlenecks between the two systems. This would enable the two systems to work together as if they were a single network. This would benefit residents and businesses on both sides of the border. Other benefits would include cost savings for consumers, as larger electricity systems operate more efficiently than smaller ones.

The North South Interconnector would also allow for greater connection of renewable generation. This would help Ireland and Northern Ireland achieve their renewable energy targets.

For the purpose of the 2016 TYTFS analysis, this project is planned to be installed and commissioned by winter 2020. Once this connection is established, the constraints on the existing Tandragee-Louth 275 kV double circuit will be significantly reduced.

2.7 Connection of New Generation Stations

New generators will connect over the period covered by this statement. Table 2-6 lists the transmission system developments associated with future generation. New generators are included in the appropriate network models according to their expected connection date. Details of these generators and their expected connected dates are given in Section B.2 in Appendix B.

Table 2-6 Transmission System Station Development to Facilitate the Connection of Future Generation

Generator	Planned Connection Method	Location
Athea Wind Farm (Extension)	Connected into the existing Athea 110 kV substation	Ireland
Barnadivane	New Barnadivane 110 kV Station, looped into the Dunmanway-Macroom 110 kV circuit	Ireland
Boggeragh 2	Connected into the existing Boggeragh 110 kV substation	Ireland
Booltiagh Wind Farm (Extension)	Connected into the existing Booltiagh 110 kV substation	Ireland
Brockaghboy	Assumed to be connected at 110 kV into the future Rasharkin 110/33 kV substation	Northern Ireland
CAES	Assumed connected into Ballylumford 275/ 110 kV substation at 275 kV	Northern Ireland
Cam Cluster	Future Cam 110/33 kV cluster substation is assumed to be connected via a loop in to the existing Coolkeeragh-Coleraine 110 kV circuit	Northern Ireland
Castletownmoor	Connected into Gorman 220 kV substation	Ireland

Generator	Planned Connection Method	Location
Clahane Wind Farm (Extension)	Connected into the existing Clahane 110 kV substation	Ireland
Coomataggart	Connected into the planned Ballyvouskill 220 kV substation	Ireland
Cordal	Construction of the new Cordal 110 kV station tailed out of Ballynahulla.	Ireland
Cronacarkafree	Connected into the planned Clogher 110 kV substation	Ireland
Cuilleen	Connected to a new Cuilleen 110 kV substation, itself tail-connected into Athlone 110 kV substation	Ireland
Curraghmulkin Cluster	Future Curraghmulkin 110/33 kV cluster substation tail-connected into Omagh South 110 kV substation	Northern Ireland
Garvagh Cluster	Future Garvagh 110/33 kV cluster substation is planned to be connected via a loop in to the Rasharkin – Brockaghboy 110 kV circuit.	Northern Ireland
Gort Cluster	Future Gort 110/33 kV cluster substation into the future Omagh-Tamnamore 110 kV circuit	Northern Ireland
Keelderry	Connected to a new Slievecallan 110 kV substation, itself tail-connected into Ennis 110 kV substation	Ireland
Loughaun North		
Kells Cluster	Future Kells 110/33 kV cluster substation is planned to be tail-connected into Kells 275/110 kV switching station at 110 kV.	Northern Ireland
Kelwin	Connected into Kilpaddoge 220 kV substation	Ireland
Knockacummer	Permanent connection of the new Knockacummer 110 kV substation, tailed out of Ballynahulla.	Ireland
Knockranny	Connected into the existing Salthill-Screebe 110 kV circuit	Ireland
Mayo Renewable Power	Connected into the new 110 kV busbar at Tawnaghmore 110 kV substation.	Ireland
Moneypoint	Connected into Moneypoint substation at 110 kV	Ireland
Mulreavy	New Mulreavy 110 kV substation tail-connected into the planned Clogher 110 kV substation	Ireland
Newtownstewart Cluster	Future Newtownstewart 110/33 kV cluster substation is assumed to connect via a loop in to the existing Omagh-Strabane 110 kV circuits 'A' and 'B'	Northern Ireland
Nore Power	Construction of Nore 110 kV substation, tailed out of Kilkenny 110 kV station	Ireland
Oriel	Connected into the existing Louth-Woodland 220 kV circuit	Ireland
Oweninny Power 1	Connected into the existing Bellacorick 110 kV substation	Ireland
Oweninny Power 2	Connected into the existing Bellacorick 110 kV substation	Ireland
Oweninny Power 3	Connected to a new Bellacorick 400 kV substation, itself tail-connected into the new Flagford 400 kV substation	Ireland
Rasharkin Cluster	Future Rasharkin 110/33 kV cluster substation looped into the Coleraine-Kells 110 kV circuit	Northern Ireland

Generator	Planned Connection Method	Location
Rhode Biomass	Connected into the Derryiron 110 kV substation	Ireland
Suir Power	Construction of Suir 110 kV substation, tailed out of Cahir 110 kV station	Ireland
Tidal	Assumed to connect into Kells 275/110 kV substation at 110 kV.	Northern Ireland
Tremoge Cluster	Future Tremoge 110/33 kV cluster substation looped into the existing Omagh-Dungannon 'B' circuit	Northern Ireland

2.8 Connection of New Interface Stations

Transmission interface stations are the points of connection between the transmission system and the distribution system or connecting 110 kV connected customers.

Table 2-7 lists the planned new 110 kV stations connecting the distribution system to the transmission system, for the period covered by this statement. These stations are included in the network models according to their expected connection date. Details of the connections and dates are given in Section B.2, Appendix B.

Table 2-7 Planned Transmission Interface Stations

Station	Code	Transformer Size (MVA)	Nearest Main Town or Load Centre	County
Airport Road	AIR	2 x 90	Belfast	Down
Ardnagappary	AGY	1x20, 1x31.5	Derrybeg	Donegal
Armagh	ARM	2 x 90	Armagh	Armagh
Ballyragget	BGT	31.5	Ballyragget	Kilkenny
Belfast North Main	BNM	2 x 90	Belfast	Antrim
Bracklone	BRA	2 x 20	Portarlinton	Laois

2.9 Detailed Transmission Network Information

The all-island network schematic diagrams in Appendix A show snapshots of the existing transmission system at the beginning of July 2016 and planned developments expected by the end of 2025. The diagrams indicate stations, circuits, transformers, generation, reactive devices and phase shifting transformers.

Figure A-1 in Appendix A presents a geographical map of the all-island transmission system, as it was at the beginning of July 2016. Figure A-2 in Appendix A presents a geographical map of the all-island transmission system at the end of 2025, as planned.

The electrical characteristics and capacity ratings of the existing transmission system are included in the following tables in Section B.1, Appendix B:

- Tables B-3 and B-8 list the electrical characteristics of existing and planned overhead lines and underground cables. Equipment ratings for Ireland's transmission system are shown in MVA for winter and for summer reference temperature conditions, 5°C and 25°C respectively. The ratings of the Northern Ireland transmission system equipment are shown in MVA for winter, autumn and summer.
- Tables B-4; B-5; B-9 and B-10 list the data of existing and planned transmission system connected transformers. This includes impedance values, nameplate ratings and tap ranges. The voltage tapping range for each transformer is given as the percentage deviation from the nominal voltage ratio at the two extreme tap positions.
- Table B-6 lists details of the phase shifting transformers on the all-island transmission system.
- Table B-7 and B-11 includes the Mvar capacity data for the existing and planned reactive compensation devices.

All-Island Ten Year

**Transmission Forecast
Statement** **2016**

3. Demand

3. Demand

This chapter provides information on forecasts for the all-island demand on the transmission system.

The forecast is taken from the All-Island Generation Capacity Statement 2016-2025 (GCS) ¹ which was published by EirGrid and SONI in February 2016. The 2016 GCS contains forecasts of future energy consumption and demand levels between 2016 and 2025.

The GCS states that there will no longer be significant transmission constraints between Ireland and Northern Ireland provided the proposed North South Interconnector is in place. It therefore concludes that with the commissioning of the second North South Interconnector, the all-island system will meet the required generation adequacy standard for most scenarios during these years.

This chapter also provides an introduction to the anticipated large demand increase in the Dublin area. This anticipated demand increase is associated primarily with the connection of new data centres. The impact of these data centres on the future all-island demand forecast is also discussed.

3.1 All-Island Peak Transmission Demand

Table 3-1 presents the median winter peak transmission demand forecasts over the period 2016-2025, as published in the GCS.

Table 3-1 also compares the most recent winter peak forecasts with those from GCS 2015. The current demand forecast shows an average annual increase in winter peak demand of 1% between 2016 and 2025.

This is more than the predicted demand increase of 0.5% in the All-Island Generation Capacity Statement 2015-2024. This change is mostly due to the expected connection of data centres and forecasts of greater economic growth.

Table 3-1: Comparison of Peak Demand Forecast with Previous GCS

	2016	2017	2018	2019	2020	2021	2022	2023	2024	2025
GCS 2016- 2025 (MW)	6,687	6,769	6,818	6,858	6,916	6,966	7,051	7,140	7,229	7,313
GCS 2015- 2024 (MW)	6,532	6,561	6,585	6,614	6,646	6,678	6,729	6,788	6,847	N/A
Difference (MW)	155	208	233	244	270	288	322	352	382	N/A

It is difficult to accurately predict a peak demand figure for a particular year in the future. This is due to a number of factors that can cause fluctuations in the forecast. These factors include weather conditions, economic activity, electricity usage patterns and government policy.

The forecasts in Table 3-1 may be taken as indicative of a general trend in demand growth. These forecasts are based on the best information available at the data freeze date, July 2016.

1. http://www.eirgridgroup.com/site-files/library/EirGrid/Generation_Capacity_Statement_20162025_FINAL.pdf

The TYTFS 2016 references documents that were published at the July 2016 data freeze date. The All-Island Generation Capacity Statement 2017-2026 is due to be published. The information in the 2017 GCS however does not fundamentally impact the study results presented in the 2016 TYTFS.

3.1.1 Ireland and Northern Ireland Peak Transmission Demand

The annual peak demand figures listed in Table 3-2 are expected to occur during the winter period of each year. For example, it is expected that the 2016 peak demand forecast of 6,687 megawatts (MW) will occur in winter 2016/17. In Ireland and Northern Ireland, the winter peak demand usually occurs between 17:00 and 19:00 on a weekday evening. However, the peak demand in each jurisdiction generally does not occur on the same day.

Table 3-2 presents the all-island, Ireland and Northern Ireland winter peak demand forecasts over the period 2016-2025, as published in the GCS.

Table 3-2: All-island, Ireland and Northern Ireland Peak Demand Forecast

	2016	2017	2018	2019	2020	2021	2022	2023	2024	2025
All- Island	6,687	6,769	6,818	6,858	6,916	6,966	7,051	7,140	7,229	7,313
Ireland	4,994	5,070	5,112	5,146	5,196	5,241	5,319	5,400	5,481	5,558
Northern Ireland	1,741	1,747	1,753	1,761	1,767	1,773	1,780	1,787	1,795	1,803

As well as winter peak forecasts, we also develop summer peak and summer valley forecasts in Ireland and Northern Ireland, and autumn peak forecasts in Northern Ireland only.

The summer peak refers to the average peak demand levels that are forecast to occur during the summer period of each year. The Ireland and Northern Ireland summer peaks are combined to produce an all-island summer peak.

The overall transmission system power flows are usually lower in summer than in winter. However, this may not be the case for flows on all circuits. The capacity of overhead lines is lower during the summer period because of higher ambient temperatures. Network maintenance is also usually carried out during the summer/autumn period. Both of these factors can restrict the network, reducing its capability to transport power.

The annual minimum expected demand is referred to as the summer valley. It represents the lowest annual demand that is forecast, and is expected to occur during the summer period of each year. The Ireland and Northern Ireland summer valley demands are combined to produce an all-island summer valley demand. The summer valley cases examine the impact of the combination of low demand and low levels of conventional generation on the transmission system.

This minimum condition is of particular interest when assessing the capability of the transmission system to connect new generation. This is because with local demand at a minimum, the connecting generator must export more of its power across the transmission system.

The summer peak and valley demands occur between May and August. The autumn peak demand refers to the average peak demand value expected in the spring and autumn seasons. The autumn peak occurs between September-October and March-April.

Summer peak, summer valley and autumn peak demand forecasts can be expressed in terms of percentage of winter peak demand. These are shown in Table 3-3.

Table 3-3: Ireland and Northern Ireland Seasonal Demand Forecast as a Percentage of Winter Peak Demand

Season	Ireland seasonal demand forecast as a percentage of winter peak (%)	Northern Ireland seasonal demand forecast as a percentage of winter peak (%)
Winter Peak	100	100
Autumn Peak	N/A	86
Summer Peak	80	79
Summer Valley	35	30

These figures are consistent with historical demand data.

3.1.2 Large Demand Increases in the Dublin Area

Background

In recent years there has been an increase in the level of enquiries for connection to the transmission system in the Dublin area. This document includes information on both current demand connections and future demand opportunities. Our assessment of demand opportunities is presented in Chapter 8 and includes a section focused on the Dublin area.

The level of enquiries in the Dublin area is principally driven by the need for Information, Communications and Technology (ICT) industries and high-tech manufacturing companies to connect to a high quality power supply in the Dublin area.

Data Centres

Ireland is an attractive business location and continues to attract world-class investments. The Industrial Development Authority (IDA) Ireland has cited access to a high-quality electricity grid as critically important for attracting new investment. This is particularly important in the ICT and high-tech manufacturing sectors.

Some of the world’s best known companies have chosen Ireland as the location for their European data centre operations. Factors such as a temperate climate, stable power sources, internet connectivity and a skilled workforce have influenced their decisions. This is emphasised by nine out of the top 10 global software companies and US ICT companies locating strategic business activities in Ireland².

At present, connected data centres have a combined total capacity of approximately 290 MVA. This includes both TSO and DSO connections. Beyond this, there continues to be significant interest in connecting other data centres to the grid in Ireland. There is approximately 870 MVA of data centres with either contracted capacity for connection to the grid or in the respective TSO/DSO connection offer processes.

In addition to this, there continues to be ongoing enquiries regarding further data centres applications. To put this in context, the current winter peak demand on the all-island transmission system is approximately 6,500 MW. If all applicants currently being processed were to connect, the data centre load could account for 17% of the all-island system peak demand.

What is a data centre?

A data centre is a facility used to house computer systems and associated components, such as telecommunications and storage systems. They underpin the operations of companies in the broad ICT sector, particularly those in social media and cloud computing. The size of the individual electricity demand connections depends on the scale of the business operation. These have varied from 20 MVA with some possibly extending to 250 MVA in the final stages of development. Their use of electricity tends to be constant throughout the year. The modern world increasingly requires the retention and use of vast volumes of data, so this trend is likely to continue for the foreseeable future.

2. <http://www.idaireland.com/business-in-ireland/industry-sectors/ict/>

Impact on the System Demand Forecast

The all-island demand forecast used in this statement is based on an underlying growth rate trend of 1%. This includes a small amount of industrial block demand increases. Therefore, the potential connection of data centre demand on the scale discussed is equivalent to decades of natural demand growth. This will have an impact on the all-island system demand forecast and generation capacity adequacy. This is assessed and discussed in the All-Island Generation Capacity Statement (GCS).

The focus of the majority of the connection enquiries have been in the greater Dublin area. Depending on the number and scale of projects that materialise, new transmission solutions will be required to strengthen the grid to facilitate these connections. These transmission solutions are now under initial investigations and could vary from short lead-time to longer lead-time developments. The impact of these Dublin demand connections are described in greater detail in Chapter 8, Section 8.3.

3.2 Demand Data

Electricity usage follows some generally accepted patterns. For example, annual peak demand occurs between 17:00 - 19:00 hrs on winter weekday evenings. Minimum usage occurs during summer weekend night-time hours.

3.2.1 Generated Peak Demand³ Profiles

Figure 3-1 shows the generated peak demand profiles of Ireland and Northern Ireland on the day of the 2015 winter peak. The Ireland and Northern Ireland peaks did not occur on the same day. Peak demand for Ireland occurred on 15 January 2015, while peak demand occurred in Northern Ireland on 30 November 2015.

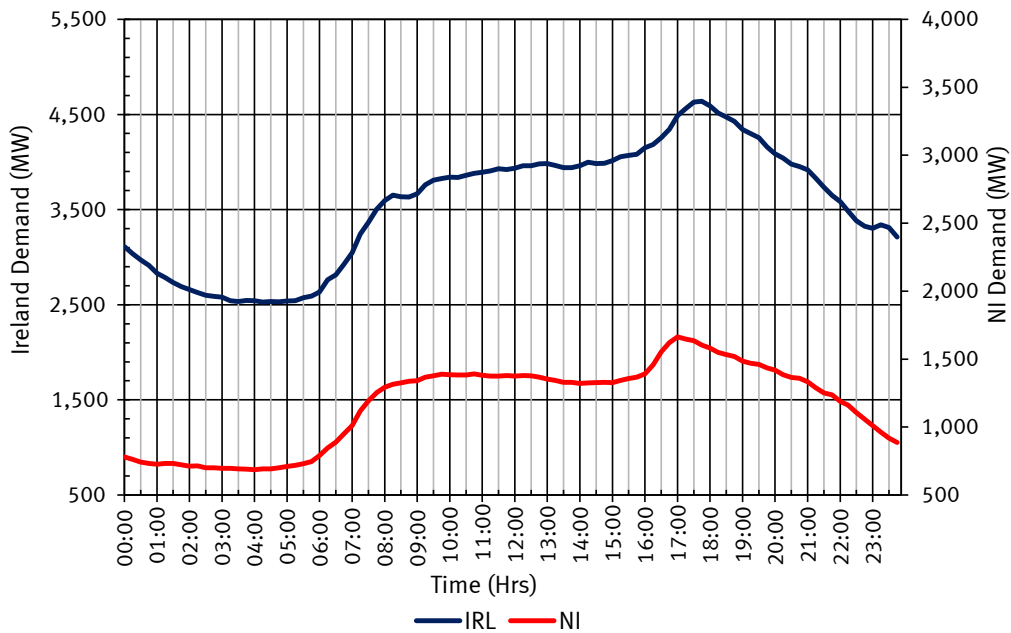

Figure 3-1 Generated Peak Demand Profiles for 2015

3. Peak demand expressed in terms of the level of generation that is required to be dispatched to serve the peak demand.

3.2.2 All-Island Demand Profiles

Figure 3-2 shows the profiles of the 2015 all-island winter peak, summer peak and summer valley. The percentage demand attributable to each jurisdiction during the peak and valley scenarios is also shown.

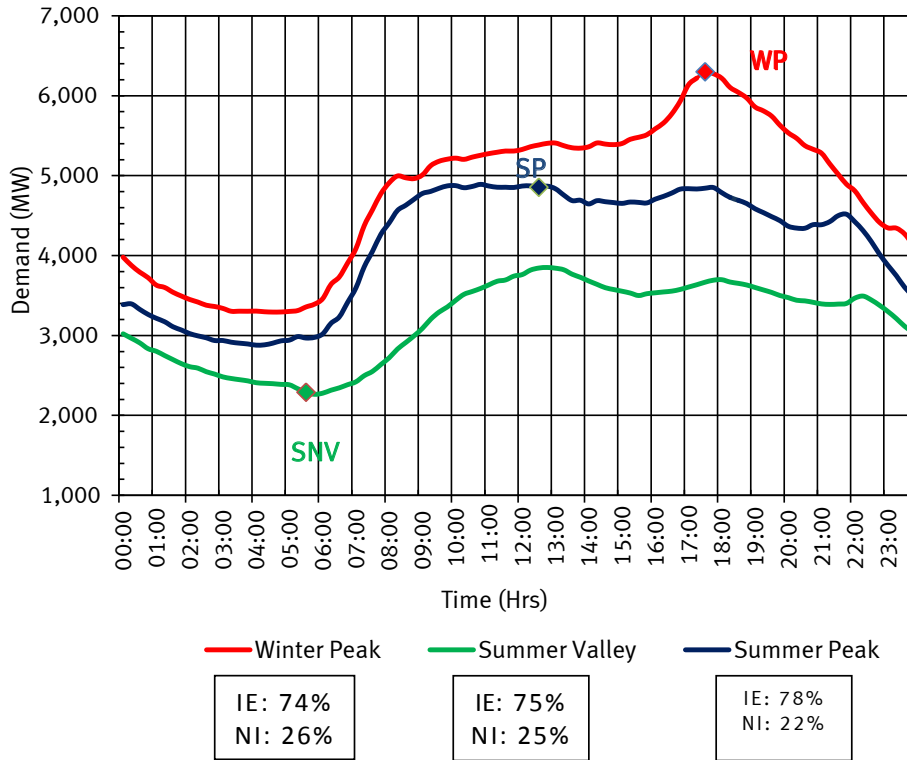

Figure 3-2 All-Island Daily Demand Profiles for Year 2015

3.2.3 All-Island Weekly Demand Peaks

Figure 3-3 shows the profile for the all-island, Northern Ireland and Ireland weekly peaks across the year for 2015.

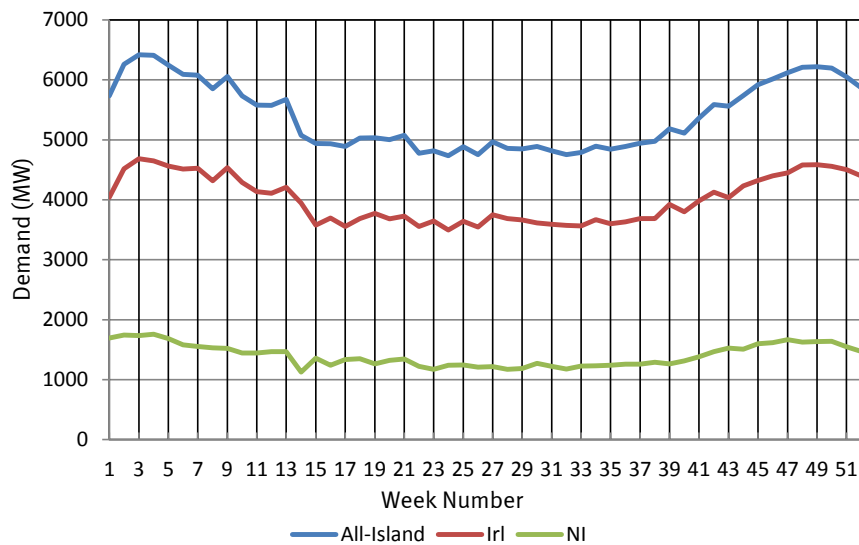

Figure 3-3 Weekly Demand Peak Values for Year 2015

3.2.4 Load Duration Curves

Figures 3-4 and 3-5 show the Ireland and Northern Ireland 2015 load duration curves, respectively. The curves show the percentage of time in the year that a particular demand value was exceeded. For example, demand exceeded 3,000 MW for 55% of the year in Ireland. Demand in Northern Ireland exceeded 1,000 MW for 53% of the year.

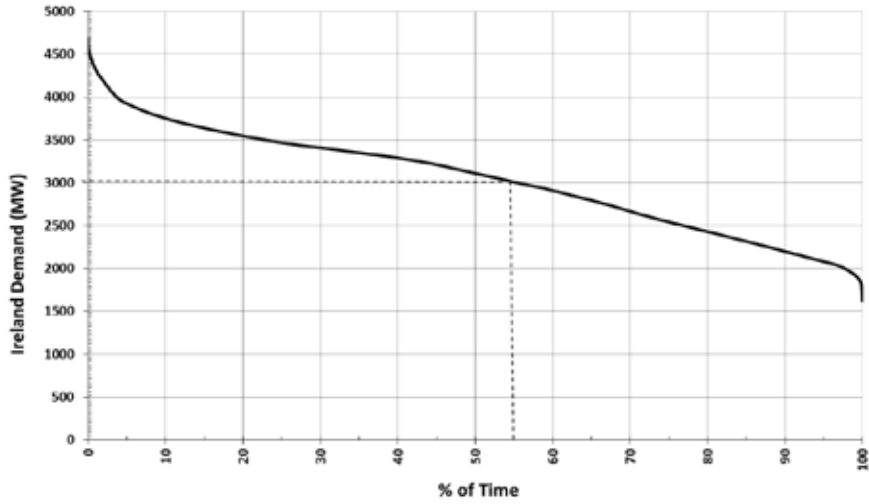

Figure 3-4 Ireland Load Duration Curve 2015

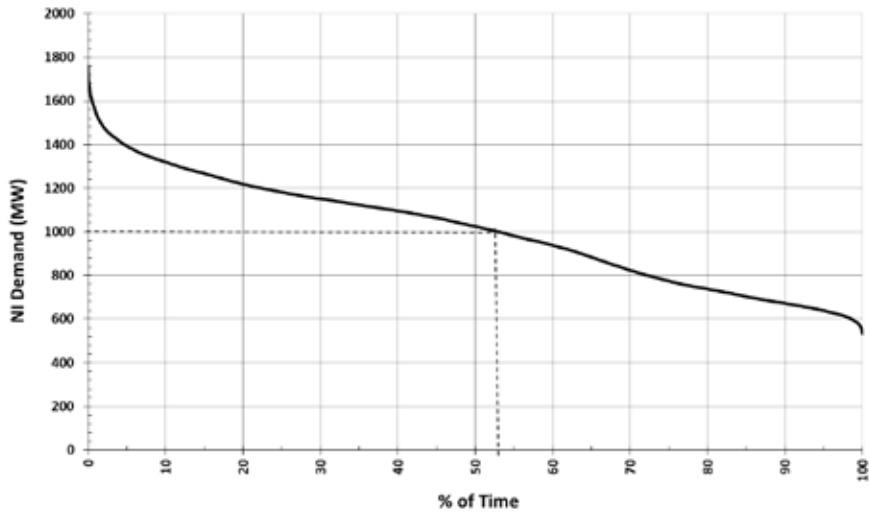

Figure 3-5 Northern Ireland Load Duration Curve 2015

3.3 Forecast Demand at Transmission Interface Stations in Ireland

Transmission interface stations are the points of connection to the transmission system. These interfaces include:

- Connections between the transmission and the distribution systems; and
- Customers connected at 110 kV.

The interfaces are mostly 110 kV stations. In Dublin city, where the Distribution System Operator (DSO) operates the 110 kV network, the interface is usually at 220 kV stations.

Appendix C lists forecast demands at each transmission interface station. The forecast demands are given for winter peak, summer peak and summer valley for all years from 2016-2025. Demand projections at individual transmission stations are developed from the system demand forecasts on a top-down⁴ basis.

The forecasting process includes regular monitoring and review of consumption trends in all parts of the country. The allocation of the system demand forecast to each station is pro-rata. This is based on an up-to-date measurement of actual peak demand at each station. Account is taken of planned transfers of demand between stations, as agreed with ESB Networks⁵. In this way, changes in the geo-diversity of electricity consumption are captured. This process provides a station demand forecast and by extension a regional demand forecast for the short to medium term.

The system-wide demand forecasts, presented in Table 3-1, include transmission losses whereas the individual station demand forecasts do not. Transmission losses therefore account for the difference between system-wide demand and the sum of the demand at each interface station. The demand at each interface is given in appendix C.

Demand forecasts for the small number of directly-connected customers are the current best estimates of requirements. In some cases, the estimates may be less than contracted maximum import capacity (MIC) values. These values are chosen to give a better projection of expected demand on a system-wide basis. However, when analysing the capacity for new demand in a particular area, the MIC values of local directly-connected customers are assumed. These values are assumed to ensure that the contracted MIC is preserved.

A demand-side unit (DSU) consists of one or more demand sites that can be instructed by EirGrid to reduce electricity demand. DSUs are usually medium to large industrial premises. A DSU uses a combination of on-site generation or plant shutdown to deliver a demand reduction. Providing this dispatch availability means that the DSU is eligible for capacity payments in the Single Electricity Market (SEM).

It is noted that DSUs may reduce some customers' demands from time to time over winter peak hours. However, normal demand levels are included in the winter peak demand forecasts shown in Table C-1 in Appendix C. Normal demand levels are also used in the power flow diagrams in Appendix H. These normal demand levels are used since they are more indicative of general power flows.

3.4 Northern Ireland Bulk Supply Point (BSP) Demand

The 110/33 kV BSP demand forecasts are provided by NIE Networks⁶. These forecasts are based on demand trends at an individual nodal level and adjusted to align with system average cold spell (ACS⁷) forecasts. Consideration is also given to future block load transfers from one BSP to another. Tables and information relating to demand forecasts are contained in Appendix C.

4. This approach takes the overall demand forecast and breaks it down - using transmission system information, including historical data - to gain better knowledge of the sub-components of the demand forecast.

5. ESB Networks is the Distribution System Operator (DSO) in Ireland.

6. NIE Networks is the DNO in Northern Ireland

7. Demand trends are based on historical information. ACS analysis produces a peak demand which would have occurred had conditions been averagely cold for the time of year. This ACS adjustment to each winter peak seeks to remove any sudden changes caused by extremely cold or unusually mild weather conditions.



All-Island Ten Year

**Transmission Forecast
Statement** **2016**

4. Generation



4. Generation

This chapter gives information about existing generation capacity. The chapter also defines future projections for the ten years 2016 to 2025. All generation capacity and dispatch figures in this statement are expressed in exported or net terms. This is the generation unit output less the unit's own auxiliary load.

In Ireland, renewable energy policy is driven by a binding European legal requirement. The requirement is for 16% of the country's total energy consumption to be met by renewable energy sources (RES) by 2020.

The Irish Government aims to achieve 40% renewable electricity, 12% renewable heat and 10% renewable transport to meet this overall requirement. 3,800 - 4,100 MW of installed wind generation will be needed to meet approximately 37% of electricity demand in 2020. The remaining 3% is expected to be sourced from hydro generation, solar, bio-energy and renewable Combined Heat and Power (CHP) energy production.

The Strategic Energy Framework (SEF)¹ 2010 for Northern Ireland sets the renewable energy policy in Northern Ireland. It states that 40% of electricity consumption in Northern Ireland should come from renewable sources by the year 2020. It should be noted that this figure is currently under review².

Currently SONI, along with NIE Networks, are working to facilitate the connection of the renewable generation required to meet the 40% target by the year 2020. This 40% government target translates into approximately 1,600 MW of renewable generation capacity in Northern Ireland³.

A freeze date for data was applied when compiling this TYTFS. This freeze date enables transmission system analyses to be carried out for inclusion in the document. The data freeze date for TYTFS 2016 is 01 July 2016, with all data accurate as at that date.

4.1 Generation in Ireland

At the data freeze date, 9,811 MW of generation capacity was installed in Ireland, as detailed in Table 4-1.

4-1

Table 4-1 Installed Generation Capacity in Ireland

Transmission System Connected (MW)	Distribution System Connected (MW)	Total Generation Capacity (MW)
8,148 MW ⁴	1,663 MW	9,811 MW

4.1.1 Existing and Planned Transmission Connected Generation

On 01 July 2016, 26 transmission connection agreements were executed for a total generation capacity of 2,008 MW. These planned generators, along with their expected connection dates⁵ are listed in Table 4-2.

Sections 4.1.3 and 4.1.4 detail planned generation developments in Ireland over the period covered by this TYTFS.

4.1.2 Planned Retirement/Divestiture of Generation Plant

The closure of generation plant could have a significant impact on the ability of the transmission system to comply with standards. The EirGrid Grid Code specifies the minimum length of notice a generator must give the TSO before retirement or divestiture. The closure of a generator with capacity less than or equal to 50 MW requires at least 24 months' notice. Generators with larger capacity than this must give at least 36 months' notice.

Some older generators will come to the end of their lifetimes over the next ten years. Tarbert units 1,2,3 and 4 are expected to be decommissioned in 2022.

1. <https://www.economy-ni.gov.uk/articles/strategic-energy-framework-2010>

2. <https://www.economy-ni.gov.uk/articles/review-costs-and-benefits-ni-executives-go-renewable-electricity-target>

3. Approximately 1,250 MW of this renewable generation capacity will be wind generation capacity.

4. Please note, this figure does not include the East West Interconnector.

5. Information correct as at data freeze date.

Other than the Tarbert units listed, EirGrid has received no other notification of plant closures. However, we have assumed that some older generators will shut towards the latter end of the 10 year period. This is for the purposes of our studies.

Table 4-2 Contracted Transmission Connected Generation

Generator	Generation Type	Generation Capacity (MW)	Expected Connection Date
Athea Phase 2	Wind	19	Jul-20 ⁶
Athea Phase 4	Wind	26	Jul-20 ⁶
Barnadivane	Wind	60	Oct-17
Cahernagh Mid Merit	OCGT	101	Aug-20 ⁶
Castletownmoor	Wind	120	Apr-17
Clahane Phase 2	Wind	14	Sep-16
Coomataggart	Wind	114	Nov-17
Cordal	Wind	101	Jun-17
Cronacarkfree	Wind	105	Jul-21 ⁶
Cuilleen	OCGT	98	Jul-20 ⁶
Dooray	Wind	55	Jul-20 ⁶
Dromada Phase 2	Wind	18	Jul-20 ⁶
Glanlee Phase 2	Wind	6	Jul-20 ⁶
Keelderry	Wind	27	Apr-17
Kill Hill Phase 2	Wind	23	Jul-20 ⁶
Moneypoint	Wind	22	Mar-17
Mulreavy	Wind	95	Sep-16
Nore	OCGT	98	Jul-20 ⁶
Oriel	Wind	210	Jul-20 ⁶
Oweninney Power 1	Wind	89	Jun-18
Oweninney Power 2	Wind	83	Jun-18
Oweninney 5	Wind	199	Jul-20 ⁶
Seecon	Wind	105	Nov-16
Sliabh Bawn	Wind	58	Sep-16
Suir	OCGT	98	Jul-20 ⁶
Ugool	Wind	64	Nov-16

6. At the date of the data freeze (July 2016), this generation project did not have an estimated energisation date available. For the purposes of our analyses, we have assumed that this project will connect over the period of this TYTFS.

4.1.3 Wind Generation

Over the past two decades wind power generation in Ireland has increased from 6 MW to 2,703 MW. The level of wind generation in Ireland is expected to grow over the period of this TYTFS. This growth in wind generation is displayed in Figure 4-1. The information presented in Figure 4-1 is a combination of connected and contracted wind generation⁷.

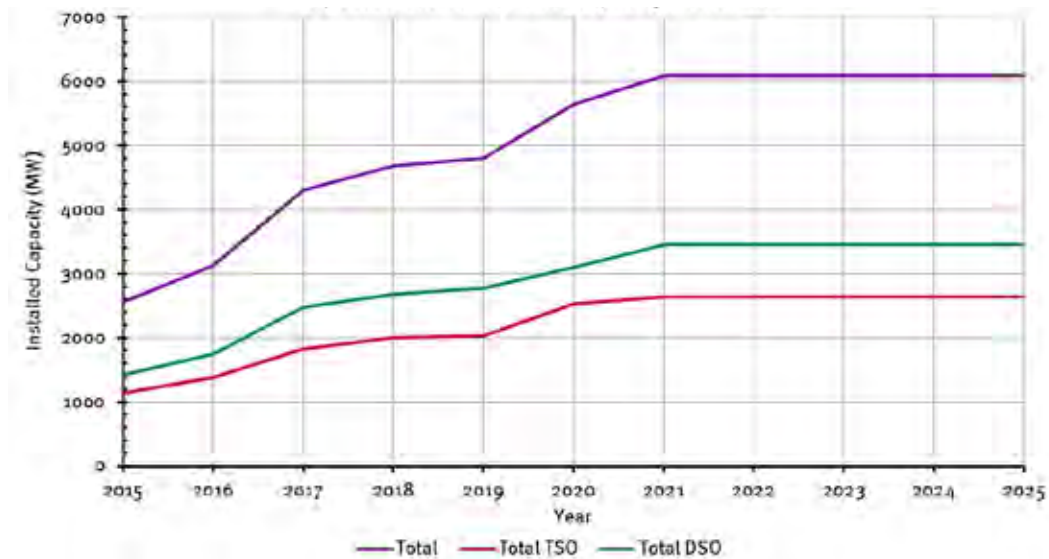

Figure 4-1 Expected Growth in Wind Capacity, 2015 to 2025

As at 01 July 2016, 167 wind farms totalling 3,351 MW have signed connection offers. These wind farms are committed to connecting to either the transmission or distribution systems over the next few years. Table 4-3 shows the level of existing and committed wind generation capacity expected to connect each year⁸, by year end.

Table 4-3 Existing and Committed Wind Capacity Totals (MW)

Connection	2016	2017	2018	2019	2020	2021	2022	2023	2024	2025
Transmission	1,374	1,828	2,000	2,025	2,533	2,638	2,638	2,638	2,638	2,638
Distribution	1,751	2,471	2,674	2,771	3,103	3,454	3,454	3,454	3,454	3,454
Total	3,125	4,299	4,674	4,796	5,636	6,092	6,092	6,092	6,092	6,092

4.1.4 Offshore Generation

Currently there is one offshore generation unit in Ireland, a 25 MW offshore wind farm at Arklow Bank. In February 2014, the Irish Government published an Offshore Renewable Energy Development Plan (ORED⁹). The aim of this work is to implement a framework for the sustainable development of offshore renewable generation in Ireland. The ORED identifies three high level goals:

- (i) That Ireland harnesses the market opportunities presented by offshore renewable energy to achieve economic development, growth and jobs;
- (ii) To increase awareness of the value, opportunities and societal benefits of developing offshore renewable energy; and
- (iii) That offshore renewable energy development does not adversely impact our rich marine environment and its living and non-living resources⁹.

7. Detailed information on these figures are as presented in Tables D-2 and D-3 in Appendix D.
 8. The individual wind farm details are included in Tables D-2 and D-3 of Appendix D
 9. <http://www.dcae.gov.ie/en-ie/energy/topics/Renewable-Energy/electricity/offshore/offshore-renewable-energy-development-plan-/Pages/Offshore-Renewable-Energy-Development-Plan.aspx>

The OREDP will also provide a structure through which Ireland can input to the development of the:

- European Blue Energy Strategy; and
- US/Ireland Memorandum of Understanding (MoU) on Ocean Energy.

The Department of Communications, Climate Action and Environment (DCCA) is leading the implementation of OREDP. It has developed a robust governance structure to deliver on the aims of the plan. EirGrid sits on the steering group and are on a number of OREDP working groups.

4.1.5 Demand Side Units

As at the data freeze date, in Ireland ten demand side units (DSU) had entered the Single Electricity Market. These DSUs have a combined dispatchable capacity of 221 MW.

4.1.6 Embedded Generation

On 01 July 2016, there was approximately 1,663 MW of embedded generation plant. This includes plant connected to the distribution system or to the system of a directly-connected demand customer. This figure comprises of small conventional and renewable units. Conventional units include CHP schemes and small industrial thermal units.

Renewable generation included in this figure consists of:

- Wind;
- Small Hydro;
- Land-fill gas (LFG);
- Tidal;
- Biogas; and
- Biomass.

Table 4-4 details the existing embedded generation capacity totals by generation type.

Table 4-4 Existing Embedded Generation in Ireland

	Wind ¹⁰	Small Hydro	Biomass/ LFG	CHP	Peaking	Total
Net Capacity (MW)	1,315	26	75	135	113	1,663

Embedded generators reduce the demand supplied through Transmission Interface Stations. Forecasts of demand levels at individual Transmission Interface Stations are presented in Appendix C. These forecasts take account of the contribution of the existing non-wind embedded generators¹¹.

The All-Island Generation Capacity Statement 2016-2025 (GCS) estimated biomass CHP to grow steadily to 204 MW capacity by 2020. It is not expected that conventional CHP capacity will change significantly during this period.

Table 4-5 shows details of the total amount of embedded generation capacity connected or committed to the distribution system at the freeze date of 01 July 2016.

10. Table D-3 in Appendix D provides details of the existing embedded wind farms and their capacities .

11. Because of the variability of wind, a fixed contribution from embedded wind farms is not taken into account in the calculation of the peak transmission flow forecasts. Rather a number of wind scenarios are considered in the TYTF analyses.

Table 4-5 Contracted Embedded Generation in Ireland

Station	Description	Connection Date
Bellacorick	10 MW wave energy generator in Co. Mayo	Mar-18
Blake	5 MW LFG generator in Co. Kildare	Oct-13
Derryiron	15 MW biomass generator in Co. Offaly	Feb-17
Drybridge	20 MW waste to energy generator in Co. Meath	Feb-11
Navan	13 MW biogas generator in Co. Meath	Dec-17
Tawnaghmore	52 MW distillate peaker generator in Co. Mayo	Jan-12
Tawnaghmore	52 MW distillate peaker generator in Co. Mayo	Jan-12
Tawnaghmore	43 MW biomass generator in Co. Mayo	Dec-17
Thornsberry	10 MW biomass generator in Co. Offaly	Sep-15
Tullabrack	6 MW wave energy generator in Co. Clare	Dec-18

4.2 Generation in Northern Ireland

At the data freeze date 3,051 MW of generation capacity was installed in Northern Ireland.

Table 4-6 Northern Ireland Installed Generation Capacity

Transmission System Connected (MW)	Distribution System Connected (MW)	Total Generation Capacity (MW)
2,138 ¹²	913	3,051

The 2,138 MW connected to the transmission system consists of:

- Conventional generation; and
- Slieve Kirk Wind Farm¹³

4.2.1 Existing and Planned Transmission Connected Generation

Existing Conventional Generation

In Northern Ireland, conventional thermal generation plant can be split into two contractual categories:

- Plant contracted to Power NI Energy Limited PPB (Contracted Plant); and
- Independent Market Participants (Non-Contracted Plant).

Table D-6 provides a list of contracted and non-contracted generators connected to the Northern Ireland Transmission System.

Contracted Conventional Generation

Plant contracted to Power NI Energy Limited via their Power Procurement Business (PPB) under pre-vesting contracts, or contracts negotiated thereafter, totals 587 MW. It is measured as output capacity at generator terminals. Details of capacity and contract information for individual generators can be seen in Tables D-1 and D-6. The contracts contain expiry dates, though the Utility Regulator may cancel contracts at earlier cancellation dates.

12. Please note, this figure does not include the Moyle Inter connector capacity .

13. Slieve Kirk is currently the only transmission connected wind farm power station (WFPS) and has a capacity of 73.6MW.

The Power Purchasing Agreements (PPA) or Generating Unit Agreements (GUAs) cover availability, operating characteristics, payments, metering etc. These agreements cover matters such as outage planning, emissions and fuel stocks.

Independent Market Participants (IMP)

The Utility Regulator has a duty to promote competition in the generation and supply of electricity. This is in line with the EU IEM Directive (concerning common rules for the internal market in electricity 2003/54/EC). This directive was introduced in June 2003. As at 01 July 2016 there is 1,477 MW of IMP capacity in Northern Ireland.

4.2.2 Planned Retirement/Divestiture of Generation

In line with the latest information available to SONI, the following assumptions have been made. At the data freeze date, AES Ballylumford had entered into a Local Reserve Services Agreement (LRSA) with SONI for the provision of 250 MW of local reserve. This will see Ballylumford ST4 and ST5 remaining connected (at reduced capacity) until the end of 2018 with an option for SONI to extend this by a further 2 years if deemed required.

The generation output of Kilroot ST1 and ST2 is anticipated to be restricted. The restriction is due to the Industrial Emissions Directive (IED)¹⁴. The restriction includes limited emissions each year from 2016-2020, followed by severely restricted running hours from 2021-2022. Kilroot ST1 and ST2 are currently due to be decommissioned by 2024.

4.2.3 Northern Ireland Renewable Generation

Existing, Committed and Assumed Renewable Generation

Existing and committed renewable generation in Northern Ireland is shown geographically in Figure 4-2. Committed renewable generation projects are generation projects that have accepted connection offers.

As well as existing and committed generation, TYTFS 2016 includes some renewable generation projects that are not committed but are assumed to be commissioned in Northern Ireland between 2016-2025.

These are also shown in Figure 4-2. These assumptions have been derived from a number of sources. The sources include:

- NIE Networks;
- The Strategic Energy Framework for Northern Ireland¹⁵;
- The Strategic Environmental Assessment of offshore wind and marine renewable energy¹⁶; and
- The Onshore Renewable Electricity Action Plan (OREAP)¹⁷.

14. <http://ec.europa.eu/environment/industry/stationary/ied/legislation.htm>

15. <https://www.economy-ni.gov.uk/articles/strategic-energy-framework-2010>

16. <http://www.offshoreenergy-ni.co.uk/>

17. <https://www.economy-ni.gov.uk/articles/onshore-renewable-electricity-action-plan>

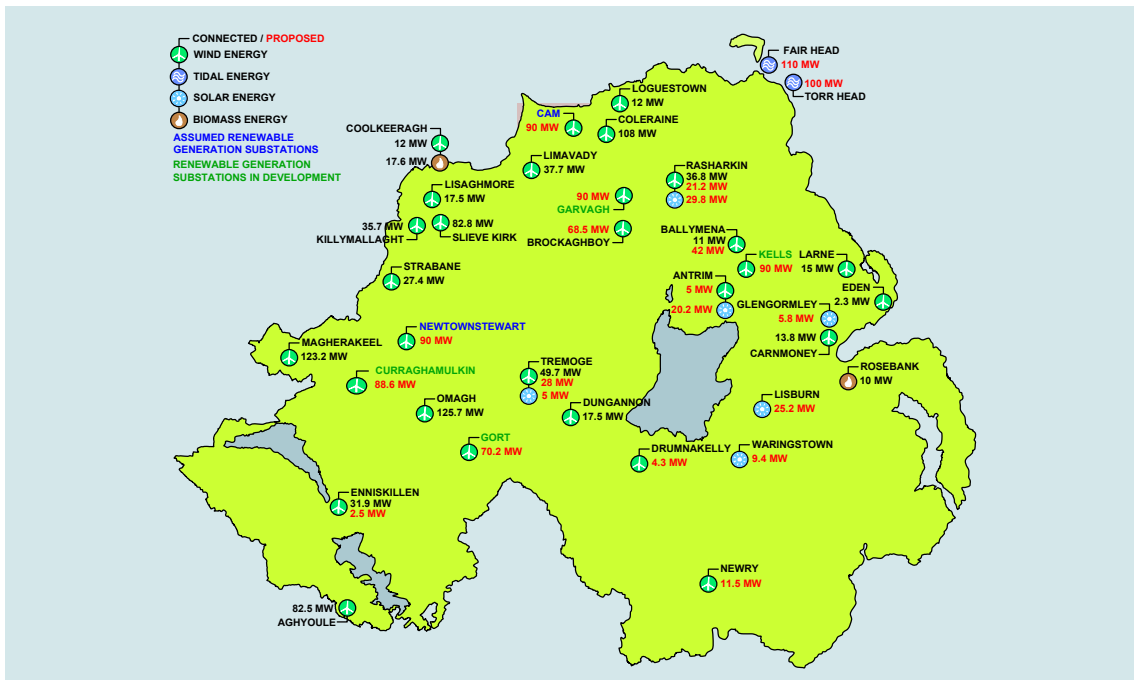

Figure 4-2 Existing, Committed and Assumed Northern Ireland Renewable Generation

The map indicates points at which renewable generation is connected to or is assumed to connect to. These points include 110/33 kV Bulk Supply Points (BSPs) and 110/33 kV Cluster substations.

In line with the criteria set out in its Distribution Charging Statement¹⁸, NIE Networks, in its role as Distribution Network Owner (DNO), have identified a number of Cluster¹⁹ substations that they wish to develop.

These distribution generators would connect into the cluster at the 33 kV level. SONI would be responsible for the delivery of the transmission elements of the Cluster substation. One such Cluster substation already exists in Northern Ireland at Magherakeel.

Some of the cluster projects included are already under development, including:

- Curraghamulkin;
- Garvagh;
- Gort²⁰; and
- Kells.

18. Statement of Charges for Connection to the Northern Ireland Electricity Networks' Distribution System: <http://www.nienetworks.co.uk/documents/Connections/NIE-Distribution-Connection-Charging-Statement-30.aspx>

19. A 110/33 kV substation in the vicinity of a number of distribution generator locations

20. This project has since been completed.

The current plan is to bring the Garvagh and Kells clusters forward as part of the Phase 1 Alternative Connection Application and Offer Process²¹. The cluster projects assumed to connect are the Newtownstewart and Cam clusters. SONI and NIE Networks have decided to look at the Newtownstewart and Cam clusters as part of Phase 2, as both of these clusters are located in the West of Northern Ireland where there is currently no firm transmission capacity remaining. These clusters were not in development when the Connection Application and Offer Process was implemented. These clusters will be progressed when there is more certainty over investment in the transmission system beyond the 2020 40% renewables target. Renewable generation included in the TYTFS study files is detailed in Appendix D. The totals are derived from locational and capacity information²² on:

- Renewable generation schemes that are connected to the Northern Ireland network;
- Schemes that are currently in construction; and
- Schemes approved by the planning service.

Offshore Renewable Generation

Our assumptions regarding the level and location of offshore generation connected to the NI transmission system are based on best information available at the data freeze date.

For the purpose of TYTFS analyses we assume that by 2025 there will not be any offshore wind connected. However, development rights are in place for tidal sites in Northern Ireland’s coastal waters.

The development rights were announced for two 100 MW tidal developments along the north coast. The developers granted these developments rights, have been in contact with SONI regarding the connection of off-shore renewable generation.

Compressed Air Energy Storage

Gaelectric is proposing a Compressed Air Energy Storage (CAES) Plant in the Larne area, to be connected to the transmission system. This energy storage facility could provide ancillary services and balancing facilities for renewable generation. SONI has accepted an offer with Gaelectric Energy Storage for this project for the capacities noted in Table 4-8.

4-8

Table 4-8 Minimum and Maximum Generation/Storage of CAES Units

Unit	Minimum (MW)	Maximum (MW)
Generator 1	16.8	168
Generator 2	16.8	168
Pumping 1	68	125
Pumping 2	68	125

A CAES plant uses a large compressor to store excess energy off the grid. It does this by converting the excess electric energy into compressed air which is stored in an underground geological cavern. This is then released through an electric generator for later use. This technology can be applied to store surplus renewable energy, while also enabling variability balancing on the transmission system.

CAES has gained Project of Common Interest (PCI) status. In 2015, it was awarded Connecting Europe Facility (CEF) grant funding of up to €6.45 million to complete, among other things, the environmental impact assessment (EIA) and submission of planning application. The project was further awarded a CEF grant of €90 million to contribute towards the implementation of the project.

21. [http://www.nienetworks.co.uk/documents/Generation/Alternative-Connection-Application-and-Offer-P-\(i\).aspx](http://www.nienetworks.co.uk/documents/Generation/Alternative-Connection-Application-and-Offer-P-(i).aspx)

22. Based on assumptions as at data freeze date – 01 July 2016.

Other Energy Storage Facilities

Other companies are investigating the potential for additional energy storage facilities in Northern Ireland. These have not been included in the analysis for this statement. Projects will be included in future analysis as connection applications/agreements are put in place.

4.2.4 Embedded Generation

Existing Embedded Generation

Table 4-9 shows a breakdown of the existing Northern Ireland Embedded Generation.

Table 4-9 Northern Ireland Embedded Generation

Generation	Net Capacity (MW)
Large Scale Wind	599
Small Scale Wind	94
Large Scale Biomass	17
Small Scale Biomass	5
Small Scale Solar	77
Small Scale Hydro	5
Landfill Gas	15
CHP	11
AGU	89
Tidal/Wave	1
Total	913

There is a total of 89 MW of Aggregated Generating Units (AGUs) in Northern Ireland registered in the SEM by three parties.

Two of these AGUs, iPower and EmPower, consist of mostly distribution connected diesel generator sets located around Northern Ireland. The third, ContourGlobal, consists of CHP gas generation. These units currently participate in the SEM.

There is 11 MW of CHP plant connected to the Northern Ireland Distribution System. This 11 MW is not expected to increase in the foreseeable future.

There is currently 5 MW of small-scale hydro generation installed on the waterways of Northern Ireland. This is a mature technology. Due to the lack of suitable new locations, limited increase in the small-scale hydro is expected in the foreseeable future.

In Northern Ireland there is currently 15 MW of landfill gas generation. It is assumed that by 2024 biogas generation capacity will increase to 22 MW.

Peak load Reduction

A number of customers have been reducing energy consumption at times of peak demand. This is achieved by load shifting or by running private generation. SONI has tended to view this generation as non-permanent due to a number of factors:

- The operation of this plant is not as reliable as conventional contracted plant;
- Variable generation costs, e.g. diesel and hire charges; and
- Variable tariff price signals.

Based on winter 2015/16, generation of this type is estimated to total 9 MW. This total figure is not anticipated to increase from 9 MW in the foreseeable future.

4.2.5 Northern Ireland Generation Mix

The chart in Figure 4-3 shows all existing and planned generation in Northern Ireland over the ten year period covered by this TYTFS. Superimposed onto the chart is the median demand forecast²³ for NI. The chart illustrates a surplus of generation in relation to the demand from a deterministic point of view. However, factors such as economic dispatch, wind variability, reserve requirements and actual HVDC interconnector flows are not taken into account. The chart also shows the large increase in renewable generation expected over the next ten years. In 2015 there was a change to the Connection Offer Process in Northern Ireland²⁴. As a result of this, there is currently a large volume of renewable generation in Northern Ireland that is not committed²⁵ generation. A level of non-committed renewable generation is included in the generation mix to represent this generation.

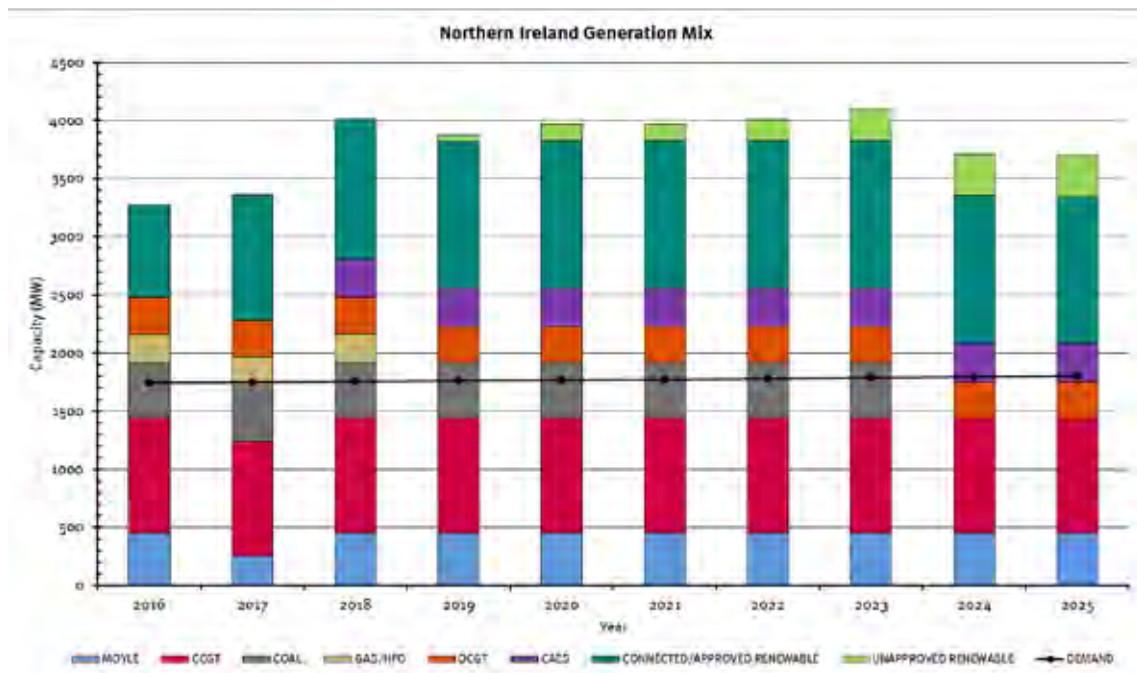

Figure 4-3 Northern Ireland Generation Mix

23. As in the All-Island Generation Capacity Statement 2016-2025.
 24. As a result of Utility Regulator (UR) Determination DET-572 of July 2015.
 25. Committed renewable generation is generation projects that have accepted connection offers.

All-Island Ten Year

Transmission Forecast
Statement **2016**

5. Transmission System Performance



5. Transmission System Performance

This chapter describes the future performance of the transmission system in terms of compliance with planning standards¹. System performance levels are assessed using:

- Forecast power flows; and
- Short circuit² current levels.

The power flow and short circuit analyses results presented in this document are based on updated information, which includes changes to:

- The existing and planned transmission system;
- Demand projections; and
- Generation connections.

This updated information is based on the best information available at the data freeze date, 01 July 2016.

5.1 Forecast Power Flows

The power flows on the all-island transmission system, at any given time, depend on:

- The transmission system configuration;
- Demand levels; and
- The output from each generator.

There are many possible combinations of generator dispatches that can meet the transmission systems' demand requirements. There are also many demand scenarios that may occur on the transmission system.

Renewable generation connected to the all-island transmission and distribution system has the effect of altering power flows. The increase in renewable generation³ is one of the main factors behind recent changes to power flows on the transmission system.

When examining transmission system performance a range of economic generation dispatches are considered. The generation dispatches used in our power flow analysis are prepared on an all-island basis⁴. Power flows across the existing 275 kV and planned 400 kV internal⁵ interconnectors are modelled to operate within transfer limits. The dispatch scenarios also consider imports and exports of power across the existing Moyle and East-West interconnectors.

Transmission system power flows are shown on the schematic diagrams found in Appendix H. The power flow diagrams show the flow of real and reactive power on the transmission system under normal conditions.

As can be seen in Appendix H, the level of renewable generation increases over the ten year period. As renewable generation increases, power flows from the West of the Island to the East can be seen to increase. This is because renewable power generated in the Western regions is supplying the larger demand levels in the East (Belfast and Dublin). These increased power flows are more significant at times of minimum demand and high renewable generation output.

Another effect that can be seen in Appendix H is the effect of increased renewable generation levels on reactive power requirements on the transmission system. At high levels of renewable generation, reactive

1. Please note that different planning standards are applied in Ireland and Northern Ireland.
2. Short circuit analysis was carried out on both the Ireland and Northern Ireland transmission systems.
3. Projected levels of renewable generation connections are detailed in Tables D-2 and D-3 in Appendix D.
4. This is reflective of how generation is dispatched in the Single Electricity Market.
5. Internal to the all-island transmission system. These are the interconnectors between Ireland and Northern Ireland. This type of interconnector is also known as a tie line.

power support is needed to keep voltages within planning standard⁶ limits. In the power flow diagrams:

- In the 2016 winter case there is 260 Mvars of reactive power support in service.
- In the winter 2024 case this figure increases to 380 Mvars of reactive power support in service⁷.

5.2 Compliance with Planning Standards

The transmission system is planned and operated to technical requirements and standards in Ireland and Northern Ireland. These requirements are laid out in the Transmission System Security and Planning Standards (TSSPS⁸) documents. These standards are in line with international standards.

The standards are deterministic⁹ – as are those generally used throughout the world in transmission planning. They set out an objective standard which delivers an acceptable compromise between the cost of development and service delivered. Rather than conducting subjective benefit analysis in each case, it is preferable to plan to meet an objective standard and carry out analysis of the options available to meet the standard.

The need for transmission system development is identified when the simulation of future conditions indicates that the TSSPS would be breached.

Ireland

Our view of future transmission needs and our plan to develop the Irish network through specific projects to meet these needs over the next ten years is presented in our Transmission Development Plan (TDP¹⁰). The TDP presents the projects which are currently being advanced to solve the needs of the transmission network. In addition, future needs that drive future potential projects are also discussed. We issue the TDP annually.

It is possible that changes will occur in the need for; scope of; and timing of the developments in the TDP. Similarly, it is likely - given the continuously changing nature of electricity requirements, that new developments will emerge that could impact the plan as presented. The long-term development of the network is under review on an on-going basis.

The TYTFS 2016 includes transmission system development projects that have received internal EirGrid capital approval. Details of these projects can be found in the TDP¹¹.

Northern Ireland

The Northern Ireland transmission projects included in the TYTFS 2016 are based on the Transmission Investment Plan. Capital projects are mainly driven by increases in Northern Ireland demand and renewable generation connection levels. Planned developments include load related and asset replacement projects. These projects mainly impact on the rating of switchgear¹² and circuits. Details of these projects can be found in Chapter 2.

6. This refers to the Ireland and Northern Ireland planning standards. ([TSSPS Ireland](#) applies to the Irish transmission system and [TSSPS Northern Ireland](#) applies to the NI transmission system.)

7. This is in addition to reactive power that is supplied by online generation.

8. The Irish transmission system is developed in accordance with the TSSPS Ireland: <http://www.eirgridgroup.com/site-files/library/EirGrid/EirGrid-Transmission-System-Security-and-Planning-Standards-TSSPS-Final-May-2016-APPROVED.pdf>
The Northern Irish Transmission System is developed in accordance with the TSSPS Northern Ireland: <http://www.soni.ltd.uk/media/documents/Projects/Publications/Northern%20Ireland%20TSSPS%20-%20September%202015.pdf>

9. The deterministic methodology is often referred to as the N-1 criterion. The system must have sufficient capacity so that in the eventuality of a probable system outage, there are no resulting system problems such as overloading, under-voltage, over-voltage or instability.

10. This is not an all-island document. The latest version of the Irish Transmission Development Plan is available at www.eirgridgroup.com.

11. Please note, TDP 2016 is based on a data freeze date of April 2016.

12. Devices used to control, protect and isolate electrical equipment.

5.3 Short Circuit Current Levels¹³

Short circuit currents¹⁴ occur during a fault condition on the transmission system. Depending on the type of fault, these short circuit currents can be very high. All transmission system equipment must be capable of carrying these very high currents.

Protection devices, in particular circuit breakers, must be capable of closing onto high currents created by a fault on the transmission system. They must also be capable of interrupting high currents to isolate a fault. Correct operation is essential for minimising risk to personnel and preventing damage to transmission equipment. Correct operation of protection devices is also necessary for maintaining system stability, security and quality of supply.

Short circuit current levels must be considered as the transmission system is developed and as new generation or demand is connected. In Ireland the EirGrid Grid Code specifies short circuit levels at the transmission connection point. These values are shown in Table 5-1. Users connecting to the transmission system are required to design their plant and apparatus to these specified levels. Equipment at lower voltage levels must also be designed to withstand short circuit current levels.

Table 5-1: Standard Equipment Rating and Maximum Design Short Circuit Currents

Voltage Level (kV)	Standard Equipment Short Circuit Rating (kA)		
	Ireland		Northern Ireland
400	50		50
275	n/a		40
220	40		n/a
110	Countrywide	25 ¹⁵	40
	Designated sites	31.5	

Table 5-1 also includes short circuit requirements for new users connecting to the Northern Ireland transmission system. Northern Ireland system users are recommended to design their plant and apparatus to withstand short circuit current levels set out in Table 5-1, as a minimum. The design of a user’s plant is also subject to detailed short circuit current level assessment.

Changes to the transmission system or the addition of generation can increase the short circuit current levels at nearby¹⁶ stations. Forecast increases in short circuit current levels can indicate transmission system equipment at risk of having its rating exceeded. Should this be the case, it may be necessary to replace this equipment with higher rated plant. Risk mitigation measures may also be implemented to reduce short circuit current levels. Short circuit current levels are calculated for all transmission system nodes in accordance with engineering recommendation G74¹⁷. Engineering recommendation G74 is based on international standards.

The analysis was carried out for single and three phase faults, for winter peak and summer valley studies. Short circuit levels were assessed for the years 2016, 2019 and 2022, and the results are presented in section 5.3.1. A description of the calculation methods used are given in Appendix E. Appendix E also provides the results of the short circuit analysis alongside an explanation of the terms used in short circuit discussions in this document.

13. Short circuit currents can also be known as “fault levels”.

14. A short circuit current is an abnormal current that flows along an unintended, low resistance path. Short circuit currents can be extremely high and may cause harm to personnel or damage equipment.

15. New equipment installed at 110 kV level must have a short circuit rating of 31.5 kA (outside Dublin) or 40 kA (Dublin).

16. This means stations that are electrically nearby, which does not necessarily mean those geographically closest.

17. IEC 60909 was an international standard issued in 1988 which provided guidance on the manual calculation of short circuit currents in a three phase AC system. The conservative results produced by this method could result in over investment and Engineering Recommendation G74 was introduced as an outline procedure for computer-based derivation of short circuit currents.

Winter peak analysis is carried out to represent the most onerous transmission system conditions, where maximum short circuit currents on the transmission system are most likely to occur. During winter peak analysis, generators that are not providing real or reactive power are switched on in the study and dispatched at 0 MW. This measure ensures short circuit current contributions from all generator sources are considered in the studies. This ensures the most onerous, but credible, conditions are used for the calculation of short circuit current levels at each bus.

Analysis of summer valley is carried out to indicate minimum short circuit currents on the transmission system based on intact network conditions. The minimum short circuit current at each bus is dependent on generation dispatch and transmission system conditions. Those requiring the expected minimum short circuit current level at a particular bus are advised to contact us directly. During summer valley analysis, generators that were not dispatched were not connected to the system.

Both the maximum and minimum short circuit current level studies assume that the transmission system is in the normal intact condition. The economic generation dispatches for the winter peak and summer valley studies are presented in Appendix D.

The results presented in Section 5.3.1 are the total busbar short circuit current levels. Short circuit current that could flow through each individual circuit breaker may be less than the total busbar short circuit current. This is dependent on network configuration and conditions.

Assessment of Short Circuit Levels in Ireland

The transmission system in Ireland is designed and operated to maintain short circuit current levels below the standard equipment ratings¹⁸. In planning the system a 10% margin is applied (for example 220 kV short circuit currents will be kept below 36 kA). This is done for security reasons.

As Table 5-1 indicates, while most 110 kV stations are designated as 25 kA, the EirGrid Grid Code stipulates that certain 110 kV stations may be designated as 31.5 kA. A new station could be designated as 31.5 kA from the start, or an existing 25 kA station may be changed to 31.5 kA. When a station changes from 25 kA to 31.5 kA, the equipment at that station may need to be modified. Station equipment at lower voltages also needs to be replaced in order to comply with this design rating.

The stations currently designated with a 31.5 kA 110 kV equipment rating are; Barnahely, Cloghran, College Park, Corduff, Finglas, Kilbarry, Knockraha, Louth, Marina, Raffeen, Tarbert and Trabeg. EirGrid will annually publish an updated list of designated stations.

In Appendix E, the results for Ireland include X/R ratios, transient AC (I_k') and subtransient AC (I_k'') currents. These results provide an indication of the strength of the transmission system.

Assessment of Short Circuit Levels in Northern Ireland

The Northern Ireland transmission system is designed and operated to maintain short circuit current levels below equipment ratings. These ratings are listed in the tables in Appendix E, Section E.6.3. The individual substation ratings are based on the lowest rated equipment at each substation.

The Northern Ireland results in Appendix E include transmission substation ratings for:

- Initial Short Circuit Current (I'');
- Peak Make Current (i_p);
- RMS Break Current (IB); and
- Asymmetrical Break Current (asym B).

The I'' and i_p values are used to assess the necessary rating of electrical equipment required to close onto short circuit currents.

The IB and asymB values are used to assess the capability of electrical equipment required to open and break short circuit current.

18. These are listed at each voltage level in Table 5-1.

5.3.1 Maximum Short Circuit Current Results

Short circuit results show that a number of Northern Ireland transmission nodes are experiencing short circuit current levels close to their current rated capability. Careful management of these issues is needed to ensure levels remain within their current rated capability.

In general throughout Ireland short circuit currents are well within standard ratings. However, there are a number of stations in Dublin and Cork where short circuit current levels are above 80% of standard ratings. There are also stations in Galway, Kerry, Limerick, Clare and Offaly where short circuit current levels are high. We will continue to monitor short circuit current levels at all stations and have plans in place to ensure that they remain within safety standards.

Figure 5-1 indicates the locations where short circuit current levels are high in 2022. In Ireland the short circuit level results are represented as a percentage of standard equipment ratings. In Northern Ireland the short circuit level results are represented as a percentage of actual equipment ratings.

Three short circuit level ranges are represented on Figure 5-1:

- Yellow dots represent substations where short circuit current results are between 80% and 90% of the ratings;
- Orange dots represent substations where short circuit current results are between 90% and 100% of the ratings; and
- Red dots indicate substations where the rating has been exceeded.

Several nodes have been found to experience short circuit current levels that exceed 100% of their current rated capability. In Northern Ireland analysis indicates that the nodes at Ballylumford and Coolkeeragh will exceed 100% of their current rated capability. In Ireland Corduff, Knockraha, Kilbarry, Cashla, Blackpool and Kilpaddoge 110 kV stations exceed 100% of standard ratings. However, Corduff, Knockraha and Kilbarry 110 kV stations are designated stations, rated to 31.5 kA. We have plans in place to uprate equipment or mitigate risks at the stations identified in this analysis. In the interim risk mitigation measures such as system reconfiguration have been employed to maintain short circuit current levels at safe levels.

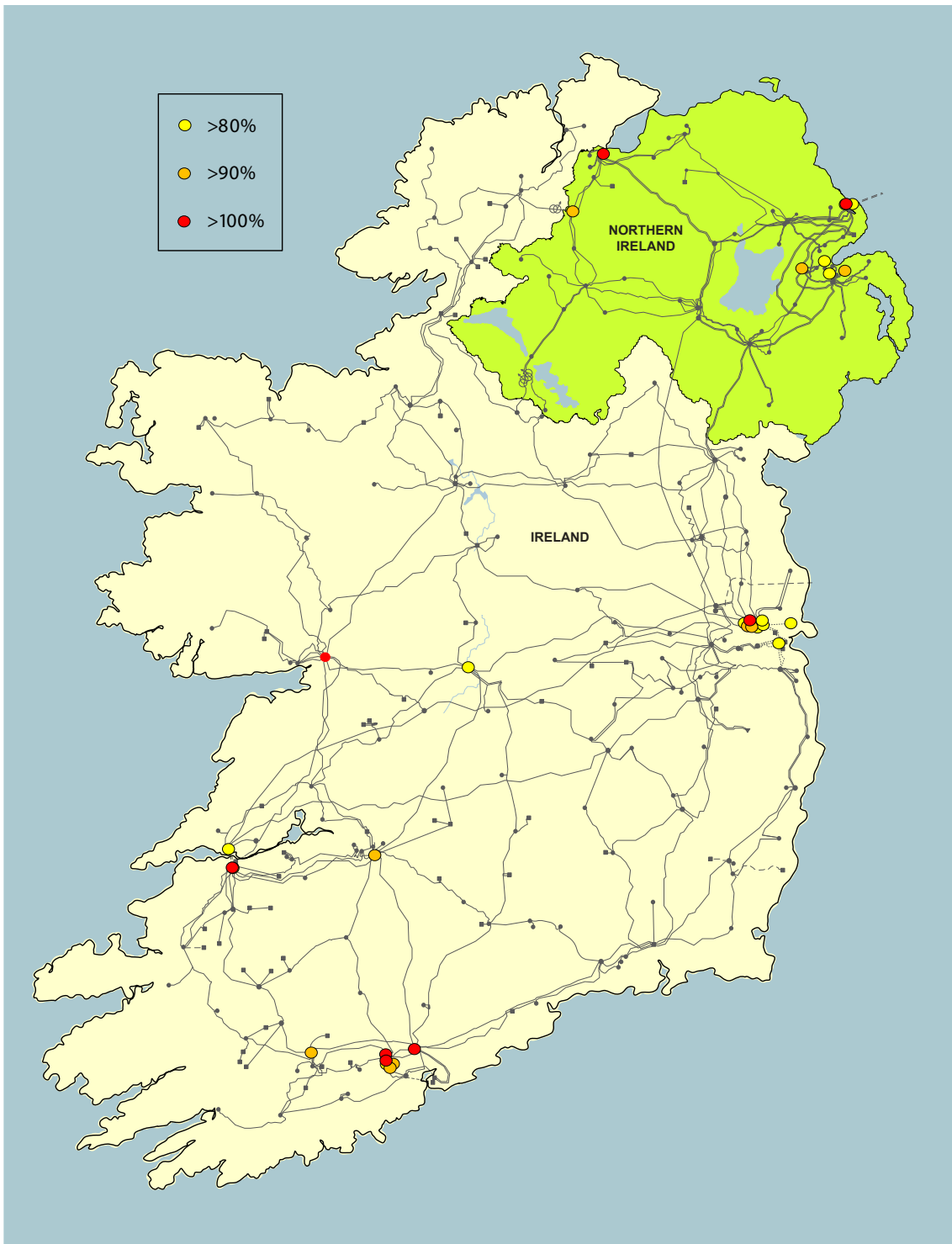

Figure 5-1: Short Circuit Current Levels for Winter Peak 2022

Table 5-2 below provides information on the transmission nodes where the short circuit current level is above 90% of equipment ratings¹⁹ in tabular form for the study years; 2016; 2019; and 2022.

Table 5-2: Nodes Approaching or Exceeding Rating

Rating (%)	2016	2019	2022
>100	BPS 110 kV	BPS 110 kV	BLP 110 kV
	CDU 110 kV ²⁰	CDU 110 kV ²⁰	CDU 110 kV ²⁰
		CPS 110 kV	CPS 110 kV
		KRA 110 kV ²⁰	CSH 110 kV
			KBY 110 kV ²⁰
			KRA 110 kV ²⁰
			KPG 110 kV
>90	BPS 110 kV	CLA 110 kV	CLA 110 kV
	CAS 110 kV	CLG 110 kV ²¹	CLG 110 kV ²¹
	COL (I) 110 kV ²¹	COL (I) 110 kV ²¹	COL (I) 110 kV ²¹
	CPS 110 kV	CSH 110 kV	HAN 110 kV
	CSH 110 kV	HAN 110 kV	KLN 110 kV
	HAN 110 kV	KBY 110 kV ²⁰	KNO 110 kV
	KBY 110 kV ²⁰	KEL 110 kV	MR 110 kV ²¹
	KEL 110 kV	KLN 110 kV	STR 110 kV
	KRA 110 kV ²⁰	KNO 110 kV	TBG 110 kV ²¹
	MR 110 kV ²¹	KPG 110 kV	
	STR 110 kV	MR 110 kV ²¹	
	TAN 110 kV	STR 110 kV	
	TBG 110 kV ²¹	TBG 110 kV ²¹	

19. In Ireland these results are presented as a percentage of standard equipment ratings. In Northern Ireland they are a percentage of actual equipment ratings. Please note the Northern Ireland results in 2019 and 2022 take account of planned switchgear upratings in deriving this percentage.

20. Short circuit current levels at Corduff, Kilbarry and Knockraha 110 kV stations exceed 100% of the standard equipment rating for 110 kV equipment - 25 kA. However these are designated stations with 110 kV equipment designed to 31.5 kA.

21. Short circuit current levels at Cloghran, College Park, Marina and Trabeg 110 kV stations exceed 90% of the standard equipment rating for 110 kV equipment - 25 kA. Again these are designated stations with 110 kV equipment designed to 31.5 kA.

Stations where the rating has been exceeded

Ireland Stations where the rating has been exceeded

In Ireland Corduff, Knockraha, Kilbarry, Cashla, Blackpool and Kilpaddoge 110 kV stations exceed 100% of standard ratings. However, Corduff, Knockraha and Kilbarry 110 kV stations are designated stations, rated to 31.5 kA.

In Ireland there are plans in place to manage short circuit current levels at the identified stations. In the interim risk mitigation measures, such as system reconfiguration have been employed to maintain short circuit current levels at safe levels.

Northern Ireland Stations where the rating has been exceeded

Ballylumford 110 kV

Short circuit current levels at the Ballylumford 110 kV node exceed the existing substation ratings. This occurs under maximum generation conditions when both of the 275/110 kV interbus transformers (IBTXs) are in service.

The existing substation is programmed to be replaced with a substation incorporating a new 110 kV GIS switchboard. This work is planned to be completed by 2020. In the interim, we manage this risk by operating with one IBTX²² out of service. This reduces the short circuit current level below the equipment rating.

Coolkeeragh 110 kV

Single-phase short circuit current levels at Coolkeeragh 110 kV substation exceed 100% of the substation assigned rating in 2019. This is a result of increased renewable generation levels. It is important that NIE Networks put plans in place to address this issue at Coolkeeragh before winter 2019.

5.3.2 Minimum Short Circuit Current Results

The minimum short circuit current results are presented in Appendix E. These results indicate minimum short circuit currents on the transmission system based on intact network conditions. These results are representative of the assumed generation dispatch and transmission system conditions.

Any parties requiring the expected minimum short circuit current level at a particular bus are advised to contact us directly.

The Moyle Interconnector has a minimum operating requirement of 1,500 MVA. This is equivalent to a short circuit current level of 3.15 kA. Below this short circuit current level the high voltage direct current (HVDC) interconnector fails to commute²³. However, as shown in Appendix E, this is not an issue over the period covered by this TYTFS.

22. Interbus Transformer.

23. Commutation is the process of reversing the direction of electric current. It is commonly used when turning alternating current to a direct current.

All-Island Ten Year

Transmission Forecast
Statement **2016**

6. Overview of Transmission System Capability Analysis

6. Overview of Transmission System Capability Analysis

This chapter describes analyses carried out to determine the capability of the transmission system to accommodate additional demand and generation. The results of these analyses¹ provide the basis for the statements of opportunity² discussed in Chapter 7 and Chapter 8.

6.1 All-Island Demand Opportunity Analysis

This section describes the demand opportunity analysis performed on the Ireland and Northern Ireland power systems. This analysis is used to determine the capability of the transmission system to accommodate additional demand connections at the defined areas. The statements of opportunity presented in Chapter 8 are a result of this demand opportunity analysis.

The all-island demand opportunity analysis is carried out for a single year, 2021. This year gives developers a useful indication as to the demand opportunities that exist in the medium-term on the transmission system. Studies are carried out for the summer period and the winter period of 2021/2022.

In Northern Ireland the demand opportunity analysis provides an indication of capability of the backbone³ transmission network to accommodate additional demand. In Ireland, the locations analysed for new demand have been carefully chosen based on feedback from industry sources. The chosen stations have been tailored to align with potential areas that are of interest to customers seeking connection to the transmission system.

It should be noted that the results of these studies are dependent on:

- Generation assumptions;
- Demand assumptions; and
- Completion dates of transmission system development projects.

Factors that may influence the results are discussed in Section 6.3.

6.1.1 Approach for Calculation of Demand Opportunity

The transmission system is planned to meet forecast demand levels at all stations in Ireland and Northern Ireland. The demand forecast for each 110 kV station is a proportion of the overall system demand forecast. This forecast is based on historical demand distributions. Future demand customers that have signed connection agreements are also included in station demand forecasts as presented in Chapter 3.

Additional demand connections above the forecast levels are not explicitly catered for in transmission system development plans. However, capacity for additional demand on the transmission system may exist at certain locations. For example, the addition of transmission system infrastructure generally provides a step increase in transmission system capacity. This addition may permit demand connections higher than forecast levels, as illustrated in Figure 6-1.

1. It is important to note that the statements of opportunity are not only based on these analyses, but also with information presented in other chapters of this document.

2. Information on how to become a customer can be accessed at the following address <http://www.eirgridgroup.com/customer-and-industry/becoming-a-customer/>.

3. The backbone transmission system connects local area networks together, enabling the efficient bulk transfer of electricity around the country and beyond.

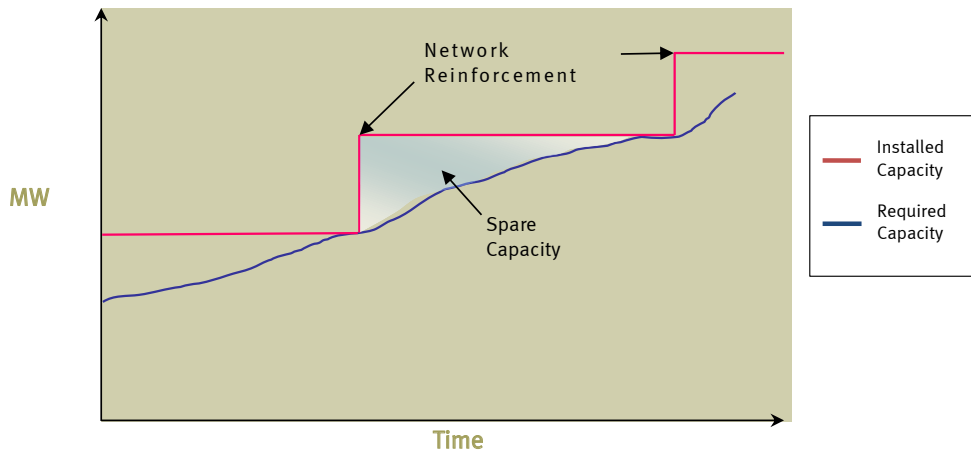

Figure 6-1: Illustration of typical step change in system capacity due to the addition of transmission system infrastructure

In Figure 6-1 the blue line represents the required MW capacity at a particular location on the transmission system. The red line represents the installed transmission system capacity. As Figure 6-1 shows, changes in installed capacity generally appear as a step increase following completion of a network reinforcement project. Therefore following a network reinforcement project there is spare capacity available on the transmission system for a period of time.

In general, demand for electricity increases over time. Figure 6-2 below displays the typical demand growth profile of a typical station. The blue line represents the demand forecast at the station. The blue bars represent potential new step increases in demand that could potentially be accommodated at this typical station.

6-2

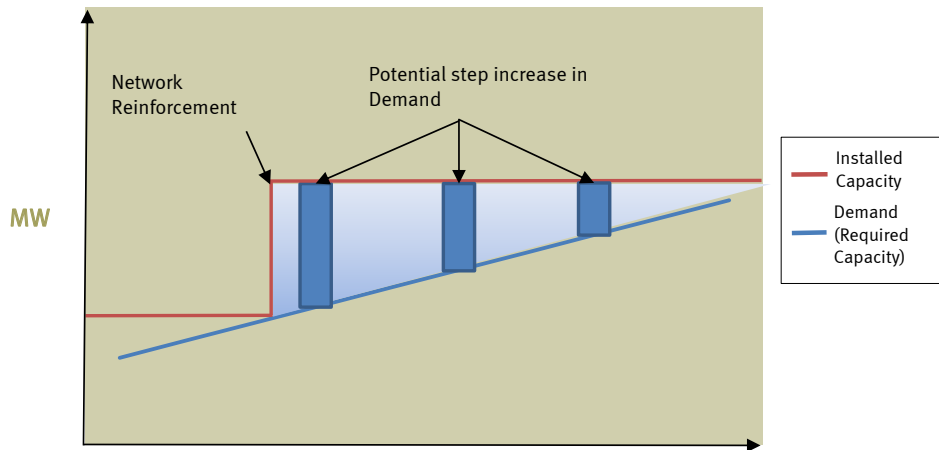

Figure 6-2: Forecast Demand Profile of a Typical Station and Station Potential to Accommodate Additional Step Increase in Demand

The analysis examines the transmission system’s capability to accept such increased demand above forecast levels. Capability to accept additional demand is examined at a number of 110 kV, 220 kV and 275 kV stations. The stations analysed are distributed throughout Ireland and Northern Ireland, as shown in Figure 8-1 in Chapter 8. The results of this analysis are useful in identifying opportunities for the connection of new or increased demand.

The opportunity value calculated is a measure of the transfer capability⁴ remaining in the physical transmission system. It provides an indication of the flexibility of the transmission system to accommodate future demand increases before additional reinforcements are required.

The transfer analysis is intended as a pre-feasibility indication of opportunity for increased demands. The method for determining capacity closely aligns with pre-feasibility study techniques.

In Ireland the application of the Irish Transmission System Security and Planning Standards(TSSPS)⁵ have been applied in the analyses of demand opportunities. The Transmission system is assessed for the loss of any single item of plant (N-1). Unlike generators, demand stations are typically not dispatchable. It is therefore necessary to assess the transmission system performance against standards for maintenance-trip contingencies (N-1-1) in the analysis of increased demand in Ireland.

In Northern Ireland, the application of the Northern Irish Transmission System Security and Planning Standards (TSSPS)⁶ have been applied for analyses of demand opportunities. The transmission system is assessed for loss of any single item of transmission plant (N-1) and loss of a double circuit (N-dc) during winter. During the summer season the Northern Ireland transmission system is assessed for N-1 as well as a maintenance-trip (N-1-1) contingency in the North-West of Northern Ireland. As the North-West is supplied by a single double circuit 275 kV spur, it requires specific attention as per the TSSPS.

Voltage analysis is performed as part of the demand capacity studies in both Ireland and Northern Ireland. This is because the addition of demand is likely to impact on local voltages levels.

6.1.2 Method for Calculating Limits for Increased Demand Connections

An AC load flow linear algorithm is used to screen critical contingencies for thermal overloads or voltage limitations.

What is a load flow?

A load flow is a numerical analysis of the flow of electric power in an interconnected system. Load flow analysis is performed on a power system model to determine steady-state (normal operation) values such as voltages, voltage angles, real power and reactive power.

What is a linear algorithm?

A linear algorithm uses an iterative approach to find the solution to a numerical problem, such as determining voltages on the power system. A linear algorithm is a simple and robust method of finding a solution.

Power transfers are considered using dispatch scenarios typically experienced on the transmission system. While these dispatches are typical, we chose them for our analysis to stress the network in terms of power transfers.

By analysing different scenarios that stress the transmission system, we can ensure that the demand opportunities reported in our analysis will not breach our Transmission System Security and Planning Standards.

The conventional units selected for each dispatch scenario align with market projections for the study year 2021.

4. Available Transfer Capability is the Total Transfer Capability, less the Transmission Reliability Margin, less the sum of existing transmission commitments and the Capacity Benefit Margin.

5. <http://www.eirgridgroup.com/site-files/library/EirGrid/EirGrid-Transmission-System-Security-and-Planning-Standards-TSSPS-Final-May-2016-APPROVED.pdf>

6. <http://www.soni.ltd.uk/media/documents/Projects/Publications/Northern%20Ireland%20TSSPS%20-%20September%202015.pdf>

Modelling Details

For single (N-1) and double circuit (N-DC) contingency studies

- Generators are modelled with their maximum output equivalent to their Maximum Export Capacity (MEC);
- Local wind generation is switched out in the vicinity of the test station⁷.

For maintenance-trip studies (N-1-1)

- Generators are modelled with their maximum output equivalent to their Maximum Export Capacity (MEC);
- Some centrally-dispatchable generation local to the test station is maximised to its MEC value⁸.

To calculate the opportunity, demand at 0.90 power factor is added to a test station in increasing amounts. This is balanced by an increase in generation⁹ outside the local test area. This is illustrated Figure 6.3 below.

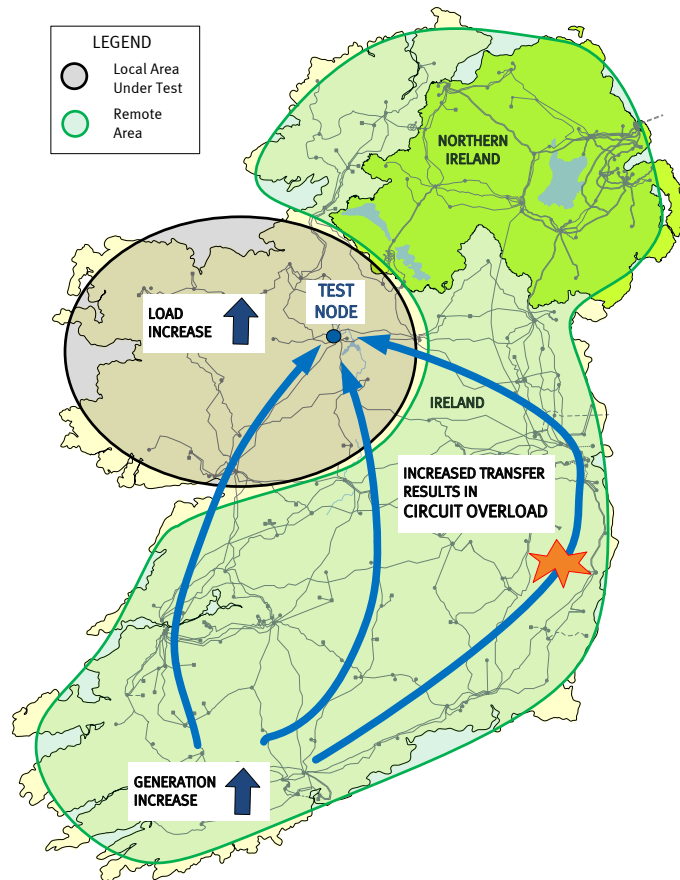

Figure 6-3: Illustration of Incremental Transfer Capability Study Method for Demand

The limit for increased transfers to the test station is then established. This is achieved by checking the post-contingency performance of the transmission system against thermal and voltage standards. This process is carried out for each dispatch scenario studied. Issues on the transmission system are not considered limiting unless they are sensitive to the incremental transfers under examination.

Calculation of Results

For single (N-1) and double circuit (N-DC) contingency studies in Ireland and Northern Ireland, and for maintenance-trip studies (N-1-1) in Ireland the demand opportunity is the minimum demand capacity result from the studies.

7. As renewable generation is classified as an intermittent energy source, it cannot be relied upon to serve demand.
 8. This is implemented to create a more favourable dispatch for the maintenance case.
 9. Generation increased as per merit order.

As noted above for the maintenance-trip studies (N-1-1) in Ireland less onerous generation dispatches can be scheduled to accommodate maintenance outages.

The results of this analysis are reported in Chapter 8 and provide an indication of the capabilities for increased demand at each station studied. It should be noted that demand opportunity is tested at each station on an individual basis. As such, the opportunities presented are not cumulative. If new demand connects in an area that is currently shown to have capacity, this will then use up some or all of the available capacity in that area.

6.1.3 Calculation of Capability for Demand in Dublin

The Dublin region is the largest demand centre on the all-island transmission system. Dublin has been and remains the focus of continual interest for the connection of large new demand.

There has been a significant upsurge in the number of enquiries and applications for new demand connections in the Dublin region and its environs since 2014. Many of these requests are for data centres. Data centres present relatively flat load profiles that impact on both the minimum and maximum demand requirements in the region. If all of these enquiries were to materialise and connect, the maximum demand of Dublin could exceed 3,000MW (see Chapter 3 Demand).

The Dublin 220 kV transmission network is operated by EirGrid, the transmission system operator (TSO). The radial 110 kV circuits are operated by ESB Networks, the distribution system operator (DSO). System development and operation in the area requires both system operators to work closely together. This is to ensure power flows are optimised and to facilitate new connections.

Due to the volume of demand enquiries and applications received for the Dublin area, and their potential impact, Section 8.3 of this document focuses on the demand opportunities in the Dublin region.

The Dublin region has been divided into three geographic zones (see Figure 8-3 in Chapter 8), namely the North, West and South clusters. This is aimed at providing a more detailed insight into the available connection capacity. This takes into account the three main corridors servicing the main bulk supply points¹⁰.

The methodology used to consider demand opportunities in the Dublin region is based on the existing transmission system. It also includes criteria, such as:

- How each zone is expected to develop; and
- The associated lead times for project delivery.

The Dublin methodology is applied in Chapter 8 Section 8.3.

6.1.4 Calculation of Capability for Demand at Any Station Outside Dublin

This section provides a general example of the analysis of the capability of any station studied in Chapter 8 to accept additional new demand. The station is tested to accommodate increased demand in summer peak 2021.

The assessment is carried out by simulating the transmission system for summer peak 2021. The relevant demand forecasts and generator dispatches are used.

Due to its variable nature, wind generation cannot be relied on to meet the demand at all times. Therefore, all wind generation in the vicinity of the test station is switched off. Studies are carried out according to the dispatch scenario assumed. The extra demand in each study is met by increasing generation according to the merit order. For each study in turn, a test demand (for example 100 MW) is added to the station under study. The power system is then analysed using an AC load flow linear algorithm.

The analysis tested an exhaustive range of N-1 contingencies (individual circuit/transformer or generator outages) to identify any resultant TSSPS violations. Thus TSSPS violations identify a capacity limit. Some contingencies cause violations of thermal overload or voltage standards at the maximum capacity. In these cases, the analysis reverts to 0 MW and performs the test in increasing steps, 10 MW in size. The test runs in increasing steps until a violation of thermal overload or voltage standards occurs. The preceding step value is then the calculated capacity value.

10. These main bulk supply points act as the transmission to distribution interfaces in the region.

In assessing opportunities for new demand, the TYTFS considers the capability of the transmission system only. The capability of the distribution system is not addressed in Ireland nor Northern Ireland. The implications for generation adequacy of demand growth above the median forecast levels are dealt with separately in the All-Island Generation Capacity Statement 2016-2025 (GCS) which is available on the EirGrid and SONI websites.

6.2 All-Island Generator Opportunity Analysis

This section describes the generation opportunity analysis performed on the Ireland and Northern Ireland power systems. This analysis is used to determine the capability of the transmission system to accommodate additional generation connections at the defined areas. The statements of opportunity presented in Chapter 7 are a result of this generation opportunity analysis¹¹.

The generation opportunity for a selection of nodes across the all-island transmission network is presented in Chapter 7. The final year of this forecast statement, 2025, is used in the analysis. The analysis is performed using an AC load flow linear algorithm, the same approach used in the demand opportunity analysis. The methodology is described in Section 6.2.1.

The harmonised all-island transmission use of system (TUoS) charge and transmission loss adjustment factor (TLAF) arrangements in SEM were introduced in last year's document, TYTFS 2015. These have an objective to provide locational signals to generators that reflect the costs they impose on the transmission system¹².

We describe the changing connection capacity locations, the impact on network power flows and the resulting effect on TUoS charges and TLAFs. These TUoS and TLAF values have an impact on power generation costs.

This approach is aimed at helping transmission network users to make informed decisions when exploring potential transmission network connection locations. Based on positive feedback to this approach, we are continuing to include this information in this year's generation opportunity analysis.

All information relating to generation opportunity presented in Chapter 7 is indicative only. EirGrid and SONI will provide guidance to transmission system users regarding the connection offer process and updates of any changes in policy that could influence generation connection opportunities on the all-island transmission grid.

6.2.1 Approach for Calculation of Generation Opportunity

Generation opportunity at a node is assessed via the use of an AC load flow linear algorithm. It is based on the premise that new generation at a particular point on the network will displace generation at a different point on the network. Figure 6-4 presents a simple illustration of the calculation methodology used for the generator opportunity analysis.

All existing generation, and all generation planned to connect in Ireland and Northern Ireland during the period covered by the TYTFS, is considered for dispatch before assessing any further generation opportunity on the all-island transmission network.

11. It is important to note that the statements of opportunity are not only based on these analyses, but also with information presented in other chapters of this document.

12. This is not the only objective of the charges and losses arrangements in SEM.

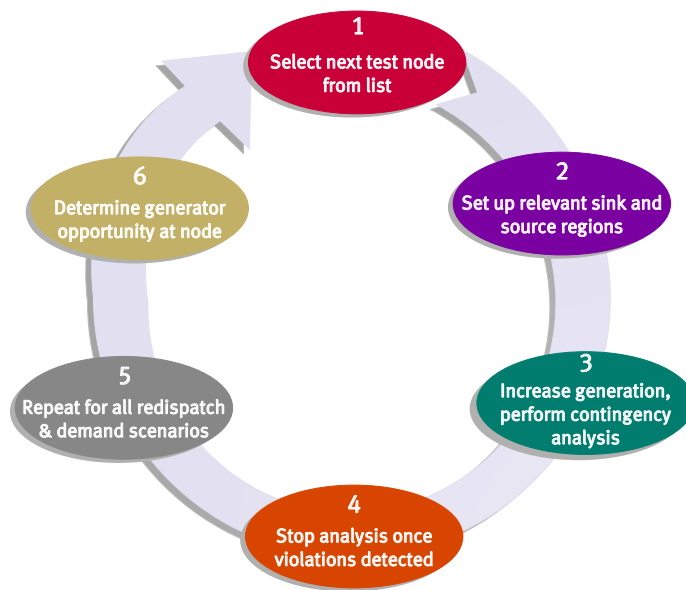

Figure 6-4: Generator Opportunities ITC Analysis Methodology

We compiled a list of 110 kV, 220 kV, 275 kV and 400 kV nodes for generation opportunity analysis. These nodes are distributed across the all-island network so that potential users can understand how opportunities vary across the network.

When testing a node, existing generation in the area around the node is maximised; this group of generators is referred to as the source region. The remaining generation required to meet the demand is dispatched based on a merit order. Finally, the test generator is then dispatched.

As the output of the test generator increases, the output from other generation in a separate area of the network - the sink area - is reduced. This forces power flows along specific corridors of the transmission network.

For each incremental increase in new generation capacity at the test node, an AC load flow linear algorithm is used to test the network for compliance with the TSSPS. The generation opportunity is determined once overloads are detected on the network.

For the generation opportunity analysis, single (N-1) and double circuit (N-DC) contingency studies only are considered.

For each node assessed, three different analyses are performed. Figure 6-5 demonstrates an example of this approach.

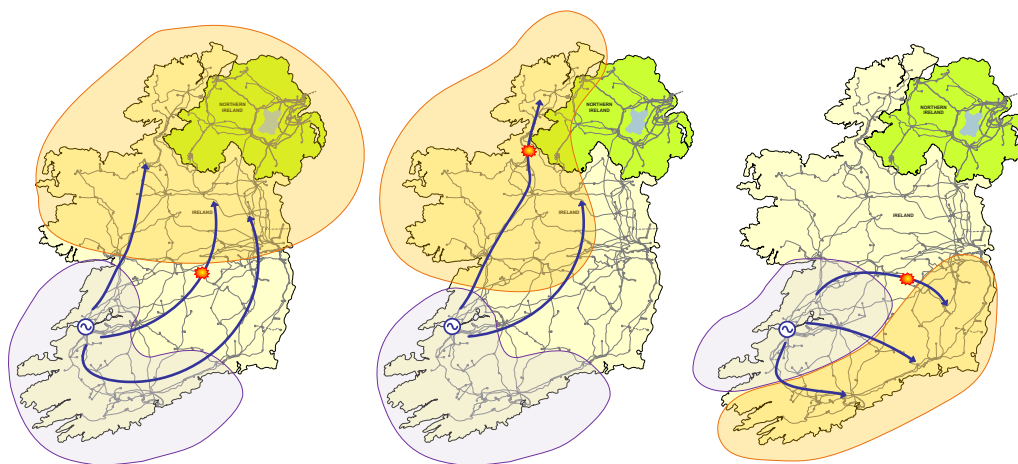

Figure 6-5: Illustration of Incremental Transfer Capability Study Method for Generation

For each scenario, the purple area represents the source region, where generation is maximised. The test generator is then increased, and generation in the orange area - the sink region - is reduced. The blue arrows represent the resulting power flows. These three scenarios are then repeated for the following network demand scenarios:

- Winter peak;
- Autumn peak (Northern Ireland only);
- Summer peak; and
- Summer valley.

The lowest result from all of the scenarios analysed is used to determine the capacity of the node under test. By analysing several scenarios across different demand scenarios that stress the transmission system, we can reasonably ensure that the generation opportunities reported in our analysis will not breach our Transmission System Security and Planning Standards.

It is important to note that results of the generation opportunity analysis are indicative only. The results of the analysis are not cumulative, as the capability of a node to accept new generation capacity is tested individually.

As transmission system operators for Ireland and Northern Ireland we are required to enter into agreement for connection with parties seeking to connect to the network.

The transmission system is planned to meet forecast generation levels at all stations in Ireland and Northern Ireland. Additional generation connections above the forecast levels are not explicitly catered for in transmission system development plans. However, capacity¹³ for additional generation on the transmission system may exist at certain locations.

Because of the relative size of individual generators, changes in generation installations, whether new additions or closures can have a more significant impact on power flows than demand. New generation capacity will inevitably alter the power flows across the network, which has the potential to create overload problems deep into the network. Problems deep into the network are resolved by network reinforcements known as deep reinforcements.

The generation opportunity analysis presents the level of generation that can be accommodated on the planned transmission system without the need for deep reinforcements to allow full network access.

13. The addition of new generation capacity will require network development to provide a path for electric power flow between the new generator and the system, known as the shallow connection.

6.3 Factors Impacting On Results

The results¹⁴ of the analyses described in this chapter are based on a set of assumptions. These assumptions are associated with:

- Future demand growth;
- Generation connections; and
- Transmission system developments.

The key forecast factors on which the results depend are dynamic. Therefore, the reality that emerges will not exactly match the forecasts. Consequently, the results, while reasonably indicative, should not be interpreted as definitive projections.

The factors likely to have an impact on the outcomes include:

- The signing of a connection agreement by a new generator;
- Delays in connection of committed new generation stations;
- Closure/divestiture of existing generation stations;
- Changes in the economy which give rise to consequential changes in the overall demand for electricity;
- Changes in demand in a particular region or area, arising from new industry developments or closures;
- Delays in the provision of transmission system reinforcements; and
- Selection and construction of new transmission system reinforcement developments which may significantly increase transmission system capacity.

14. These results are presented in Chapter 7 and Chapter 8.

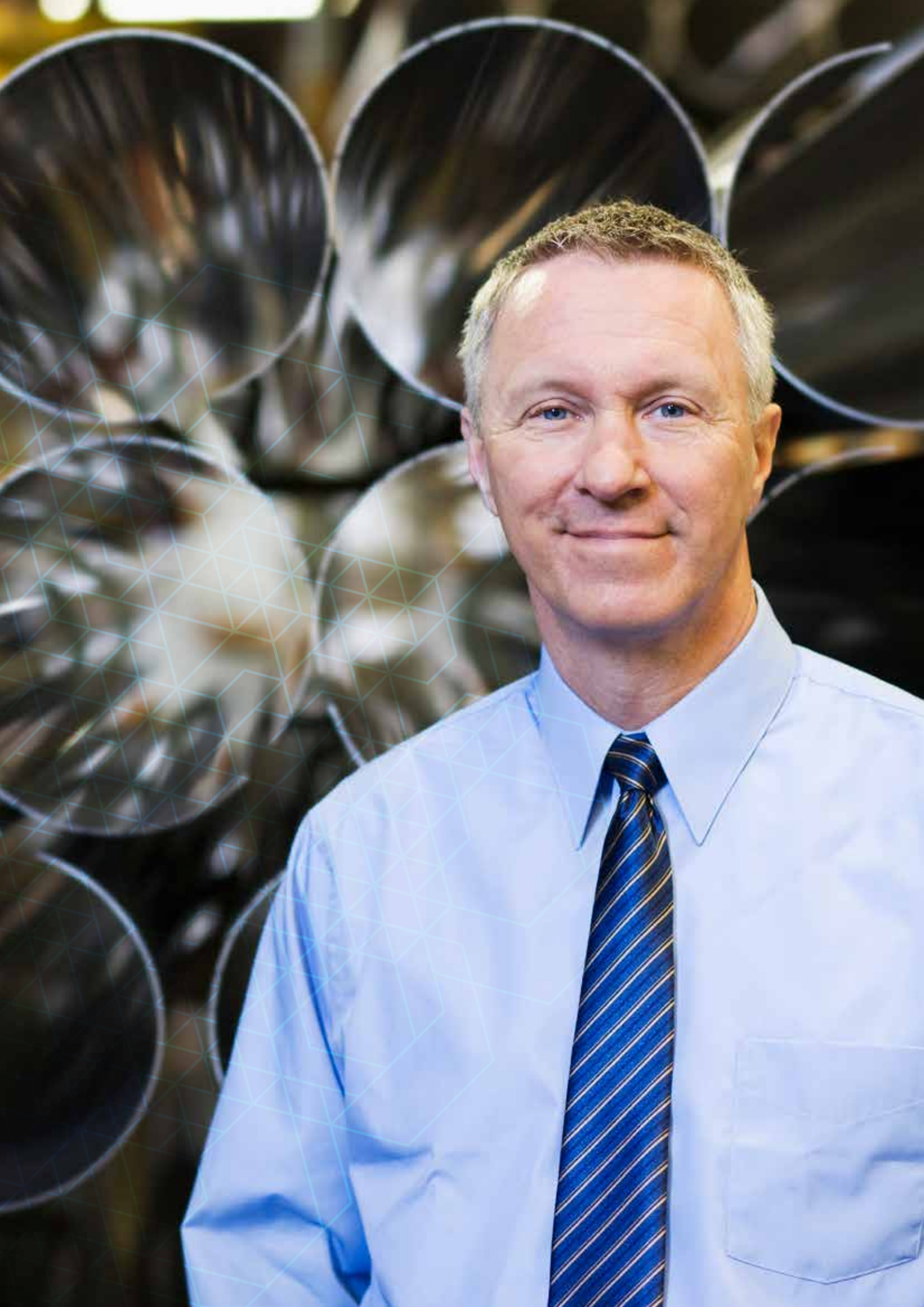

All-Island Ten Year

**Transmission Forecast
Statement** **2016**

7. Transmission System Capability for New Generation



7. Transmission System Capability for New Generation¹

7.1 Background

In this chapter we provide the results of the detailed generation capacity opportunity analysis, of which the calculation methodology is described in Chapter 6.

The analysis considers the final year of this statement – 2025 - and details the opportunity for connecting further generation beyond the assumed installed generation portfolio. The results provide potential network users with a guide to the ability of the all-island transmission system to accept new generation. It must be stressed that this analysis is indicative only; the actual transmission network capacity can only be determined during the connection offer process. This process requires detailed network assessments to determine the optimal connection arrangement that complies with the Transmission System Security and Planning Standards (TSSPS) in Ireland and Northern Ireland.

Significant changes to generation dispatch patterns and the geographical location of generation impact on all-island transmission network power flows. As a consequence, Generator Transmission Use of System (GTUoS) tariffs and Transmission Loss Adjustment Factors (TLAF) have changed, resulting in an impact on the economics and location of power generation. Resulting regional changes in TUoS and TLAFs are described to help network users make informed decisions when exploring potential transmission network connection locations.

7.2 New Generation Capacity

The level of generation expected to connect to the all-island transmission system is described in detail in Chapter 4 of this statement.

The largest recent generation capacity increase has been wind generation. At the freeze date of the 1 July 2016 there was circa. 3,400 MW connected to the all-island transmission system. Depending on project completion rates this all-island figure could increase to more than 7,000 MW of wind generation capacity by 2020 and beyond (see Chapter 4).

This generation is mainly connected in remote locations to the South-West, West and North-West of the island of Ireland. At times of high wind generation this can result in very high power flows on transmission circuits supplying power to the large demand centres on the East coast of Ireland and Northern Ireland.

In contrast there are a number of large conventional power stations due for retirement/divestiture or to have restricted output due to the EU Industrial Emissions Directive.

7.3 Generation Opportunity

This section presents the results of the Generation Opportunity analysis. The analysis only considers generation included within this document when assessing generation opportunities. Assumptions are made at the time of the data freeze date to enable routine annual reporting. Changes to generation, demand and network reinforcement projects assumptions can impact on the generation opportunities on the all-island system.

7.3.1 At Selected 220 kV, 275 kV and 400 kV Stations

This section provides the opportunities for additional generation on the 220 kV, 275 kV and 400 kV networks in 2025. For these high voltage stations, new generation of up to 400 MW in size was considered for assessment. Figure 7-1 illustrates the stations selected across the all-island network, and their resultant generation opportunity.

1. Information for potential Generator Connections can be accessed at the following address:
http://www.eirgridgroup.com/_uid/abd2c4e6-1555-4cb9-b113-4f161e687c25/index.xml

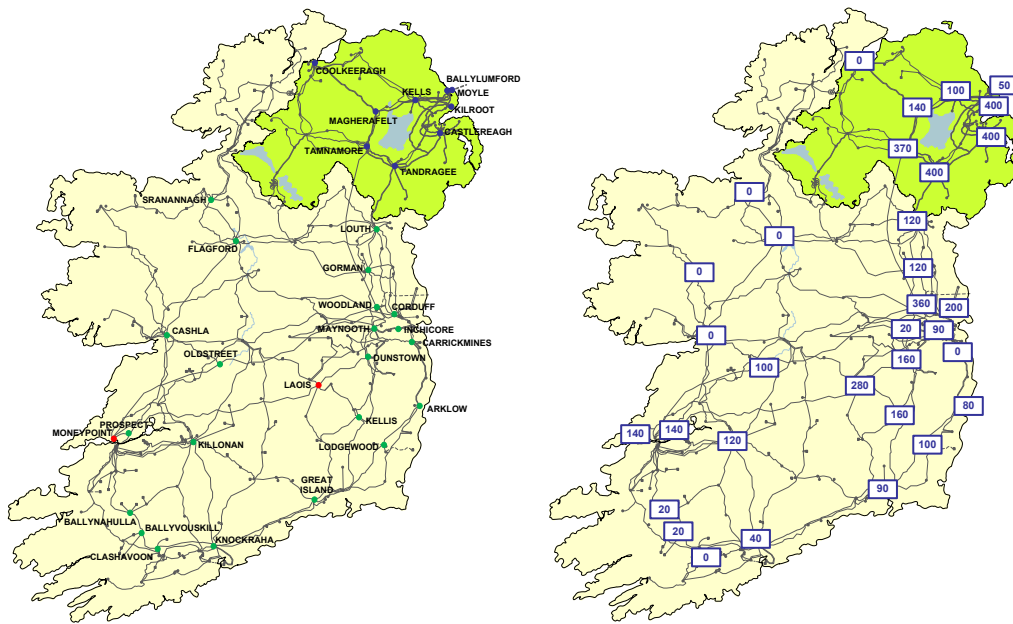

Figure 7-1: Generation opportunity at 220 kV, 275 kV and 400 kV stations in 2025

In general, there is no opportunity for new generation in the North and West of Ireland, and very limited opportunity in the South-West of Ireland. The transmission network in these areas is mainly comprised of 110 kV circuits; these areas also have significant levels of connected and planned renewable generation. As a result, there is little to no additional capacity available. The only exception is the area around Moneypoint, located close to the 400 kV network. In the East and South East regions, there is increased opportunity for new generation, being located closer to the large demand centres.

With the potential development of large data centres in the Dublin area, there will be increased generation opportunities at stations around Dublin beyond that indicated in this analysis.

In Northern Ireland, there is no opportunity for new generation in the North-West region. Similar to Ireland, this area has significant levels of renewable generation, both connected and planned, and the transmission network is almost entirely comprised of 110 kV circuits. However, there is significant opportunity on the 275 kV network towards the South and East, with 400 MW of capability at some nodes in the area around Belfast.

7.3.2 At Selected 110 kV Stations

A number of 110 kV stations were also analysed to complement the higher voltage stations analysed in Section 7.3.1. For these stations, new generation of up to 200 MW in size was considered for assessment. The stations, and their resultant generation opportunity, are displayed in Figure 7-2.

As in the previous section, the results are not cumulative, as the opportunity at each station is assessed individually. The capacities shown are relevant to the station tested, but also provide an indication of the opportunities available at neighbouring stations.

As expected, there is very little opportunity for generation connection at 110 kV. By 2025 in Ireland, there is a high level of renewable generation connected to both the transmission and distribution systems. This is concentrated in the North-West, West and South-West, and the installed capacities exceed the demand in these areas. As a result, there is little to no opportunity available anywhere in those areas.

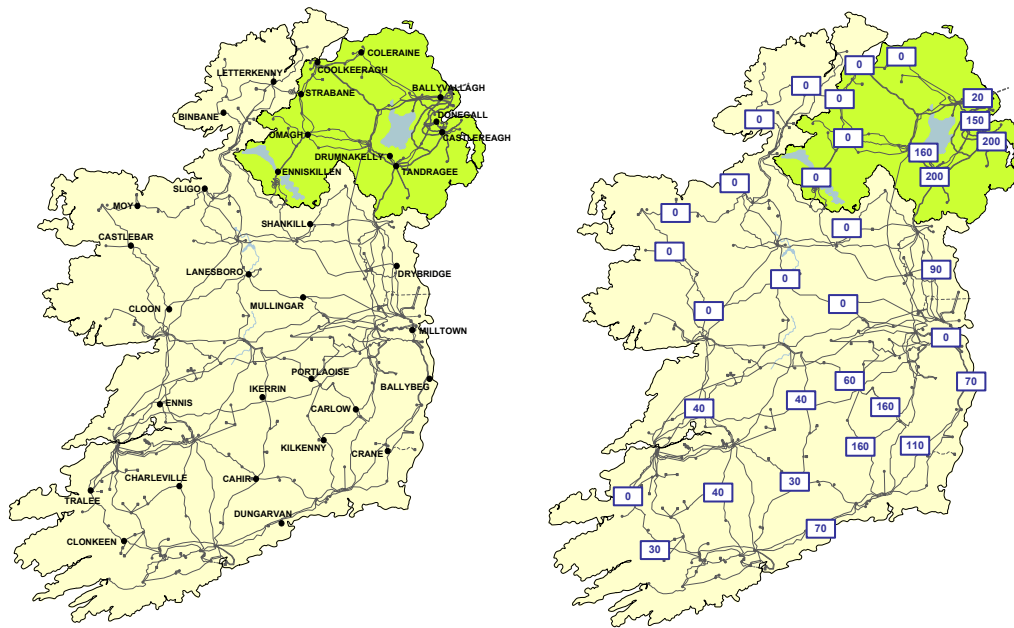

Figure 7-2: Generation opportunity at 110 kV stations in 2025

Towards the South-East and East of Ireland, there is opportunity available at 110 kV nodes. The largest demand centres are located in these areas, and the transmission network is stronger. Additionally, renewable generation penetration is lower in these areas. Connection studies would be required to determine the available capacity and connection arrangements.

Not dissimilar to Ireland, Northern Ireland is connecting high levels of renewable generation, with more planning to connect to the transmission and distribution systems by 2025. This generation in the North and West of Northern Ireland is greater than local demand and causes congestion on the transmission network.

In the East of Northern Ireland, opportunities for generation connection are possible, with a less congested transmission network and higher demand density. Again, detailed connection studies would be required to determine the available capacity and connection arrangements.

7.4 Generation Locational Tariff Signals and Their Impact on Transmission Network Capacity

Harmonised transmission arrangements provide locational signals to users reflecting the costs they impose on the transmission system. TLAFs and GTUoS charges, as part of harmonised transmission arrangements, can provide generators with locational signals informing their decision on where to connect to the grid and incentivise efficient generation dispatch.

Electrical losses, which occur as electricity is transported along transmission circuits, are accounted for in the settlement process with the application of TLAFs. Some units are responsible for proportionally more transmission losses than others, depending on their point of connection to the grid and use of transmission network capacity.

The methodology used by the transmission system operators (TSOs) to calculate the TLAFs has been approved by the regulatory authorities².

The most efficient way to transfer power in terms of losses is to minimise the distance between generation and demand, and not to heavily load lines. Due to the locality and amount of demand and generation, power can be transmitted over sizeable distances. If the power generated in a region is in excess of the demand in that region, the excess generation will be utilised some distance away from the source.

2. <http://www.soni.ltd.uk/media/documents/Archive/TLAF%20Methodology%20Explanatory%20Paper%20v1.0.pdf>

The transmission network consists of high voltage overhead lines and cables ranging from 110 kV to 400 kV. When current flows across these circuits, some energy is lost as heat. The higher the power transmitted on a line, the higher the current, and the current has a squared relationship to power losses. For example, if the power on a line is doubled, the losses will increase by a factor of four. In general, transmitting power on a higher voltage level will lower the associated current. The associated losses will be dependant on how congested the line is; increasing power on an already congested line will result in greater losses than increasing power on a less congested line.

The Transmission Use of System Charge (TUoS) is the main charge for transporting power in bulk across the power system. Generator Transmission Use of System Charge (GTUoS) contains a locational component, that provides a signal of the costs associated with a generator's use of the transmission network.

Such signals provide a commercial incentive for generators to make informed decisions (both siting/entry and exit decisions) concerning their use of the transmission system. This is intended to improve efficiency in respect of both the use of, and investment in, the transmission system.

7.4.1 TLAFs

Generator TLAFs are reflective of their contribution to transmission losses. The principle is that market participants that contribute more to transmission losses, due to their location, should have a lower TLAF, than those generators who contribute less to transmission losses. The regional average 2016/2017 TLAF values are shown in Figure 7-3, and are based on published 2016/2017 TLAF values.

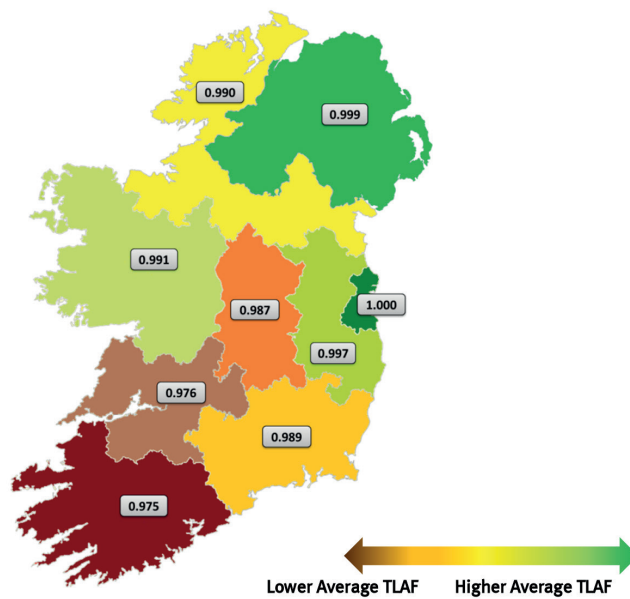

Figure 7-3: All-island 2016/2017 regional average TLAF values

Figure 7-4 shows the change in TLAFs between 2015/2016 and 2016/2017. These changes are influenced by yearly dispatch, demand and topology changes.

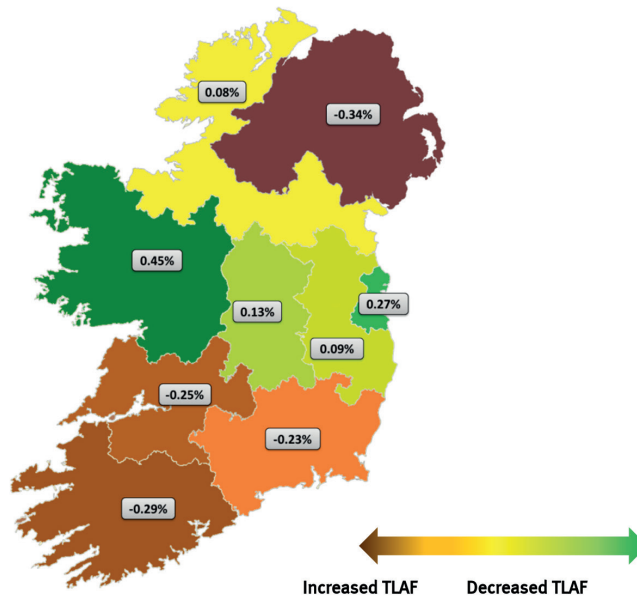

Figure 7-4 - % TLAf Change between 2015/16 & 2016/17

The information presented in Figures 7-3 and 7-4 should be used as regional indicators. For example in Northern Ireland (NI), Figure 7-4 shows the average TLAf value has decreased between 2015/16 and 2016/17; however, as shown in Figure 7-3, the TLAf value remains above average when considering the all-island network. This consideration should be taken into account when reviewing year on year TLAf changes for generators.

7.4.2 GTUoS

The regional average 2016/17 GTUoS values are shown in Figure 7-5, and are derived from the approved 2016/17 GTUoS values. Higher GTUoS charges are reflective of transmission investment costs linked to a generator’s use of the system. This promotes efficient use of the transmission system by generators, which should, in turn, facilitate efficient investment in the transmission system.

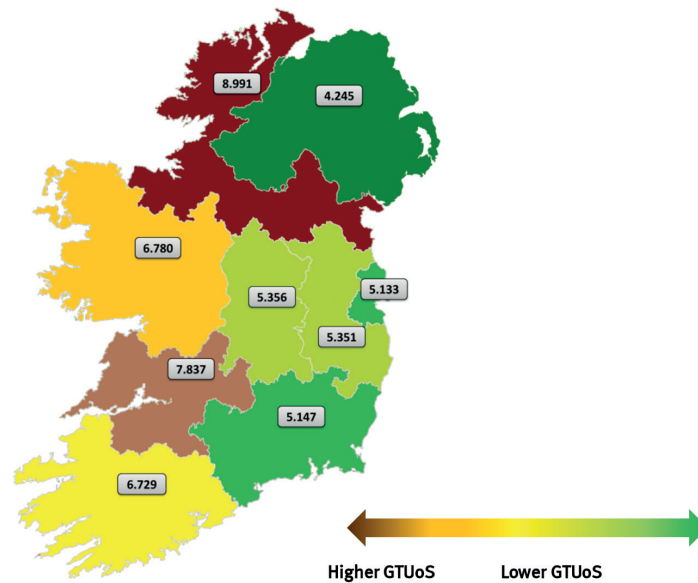

Figure 7-5: All-island 2016/17 regional average GTUoS values

Figure 7-6 shows the change in GTUoS values between 2015/2016 and 2016/2017.

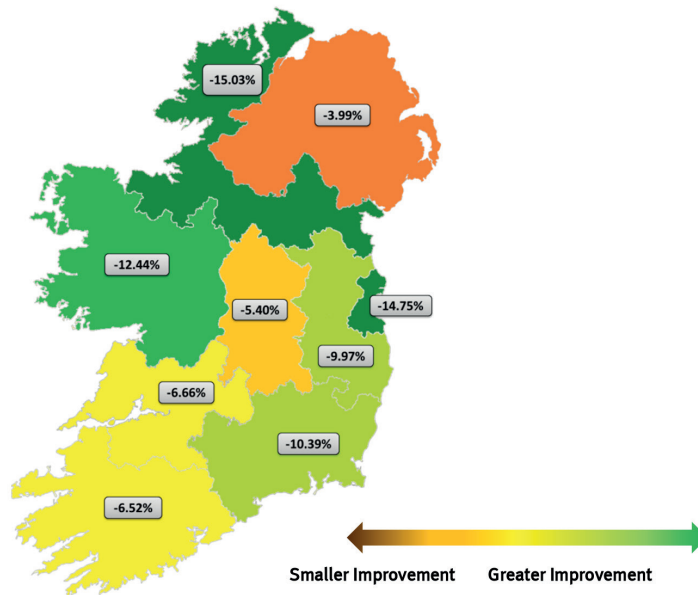

Figure 7-6: All-island 2016/17 regional average GTUoS change

As shown by Figure 7-3 and Figure 7-5, a trend similar to that of 2015/16 is apparent: regions with surplus generation capacity in the South West, West and North West have lower TLAfs and higher GTUoS values than Eastern regions with higher demand levels and less surplus generation.

For 2016/17, there is a decrease in tariffs due to a decrease in the required revenue to be recovered. GTUoS tariffs have reduced on average by 7% in 2016/2017 compared to 2015/16. Further information on the 2016/17 GTUoS tariffs, including the approved methodology, can be found on the EirGrid website³.

7.5 How to Use the Information for Generation

Generation developers wishing to use the information contained within this section when considering where to connect should follow these steps:

- Consult the maps in Appendix A to find the nearest transmission station to the proposed development. Also, review the regions and nodes identified in Section 7.3 which indicates opportunity for generation connections.
- Consult the forecasted increase and retirement/divestiture of generation within a region shown in Appendix D.
- Review assumptions in Chapters 2 to 4 and consider the impact of changes to the transmission system since the analysis was carried out. Chapter 5 and Appendix E should also be considered to determine short circuit levels at the nearest transmission station.
- Consult with EirGrid and SONI on the proposed location as early as possible as well as consulting the EirGrid application process and SONI application process.

Potential generator developers should not be discouraged by choosing a site in which there appears to be a lack of transmission network capacity. Early consultation with us is encouraged so that we can work jointly to explore options relating to any potential proposals and enable timely decision making.

3. <http://www.eirgridgroup.com/site-files/library/EirGrid/1617-Proposed-GTUoS-Tariffs-v1.0.pdf>

7.6 Looking to the Future

7.6.1 Ireland

The Commission for Electricity Regulation (CER) policy for connection of generation to the electricity network in Ireland is captured under the Group Processing Approach (GPA) and Non-Group Processing Approach directions. Under the GPA, offers for connection to the electricity network have been issued in batches called 'Gates'.

Eligibility for inclusion in a Gate has been based on criteria set out by the CER in its decisions on each of the three gates to date, Gate 1 in 2004, Gate 2 in 2006 and Gate 3 in 2008 and 2009. The Non-Group Processing Approach applies to small scale generation and specific technologies.

The CER is now reviewing the enduring connection and grid access policy to ensure it is fit for purpose for future grid access requirements. This follows the publication of CER Decision CER/16/284 on the 12th October 2016 titled "Connection Policy Transitional Arrangements".

This decision sets out the CER's decision on transitional arrangements for connection and access to the grid. It represents an initial step in the development and implementation of an integrated and enduring connection policy for the electricity system in Ireland. Potential generator project promoters should be aware of these developments. EirGrid will incorporate relevant policy directions. We will also provide assistance and guidance regarding the connection processes, requirements and arrangements for potential new transmission system users.

7.6.2 Northern Ireland

The electricity network in Northern Ireland is facing an unprecedented demand for the connection of renewable generation. In addition to connected and committed renewable generation, there is further renewable generation applications totalling 1,200 MW⁴.

This presents significant challenges for both the transmission and distribution systems. Following a consultation process with industry stakeholders on an Alternative Connection Application and Offer Process, SONI and NIE Networks issued a Decision Paper in May 2016⁵. The Decision Paper outlined SONI and NIE Networks approach to processing connection applications in the more immediate term and in the longer term. These approaches are referred to as Phase 1 and Phase 2 respectively.

The objective of Phase 1 is to release connection offers that will allow for optimal and efficient use of existing grid capacity by ensuring that projects more certain of proceeding are granted access to remaining scarce network capacity.

Given the responses received by industry, SONI and NIE Networks also proposed an outline approach to deal with the longer term situation, Phase 2, once remaining capacity is utilised in Phase 1. Importantly, given the following considerations: the industry responses received in support of reintroducing planning permission as a pre-requisite for connection application; the fact that capacity will have been exhausted; and the policy support required from the Department for the Economy (DfE) and the Utility Regulator (UR) for significant further transmission investment; Phase 2 requires significant input from policy makers and other key stakeholders.

SONI and NIE Networks are working closely with the UR on their Review of Connection Policy, and will be working towards finalising the Phase 1 Alternative Connection Application and Offer Process and, with the input of policymakers, developing an approach for connection applications beyond Phase 1.

4. <http://www.nienetworks.co.uk/Connections/Generation-connections/Latest-updates/Renewables-Integration-Status-Report>

5. <http://www.nienetworks.co.uk/documents/Generation/Alternative-Connection-Application-and-Offer-P-1>

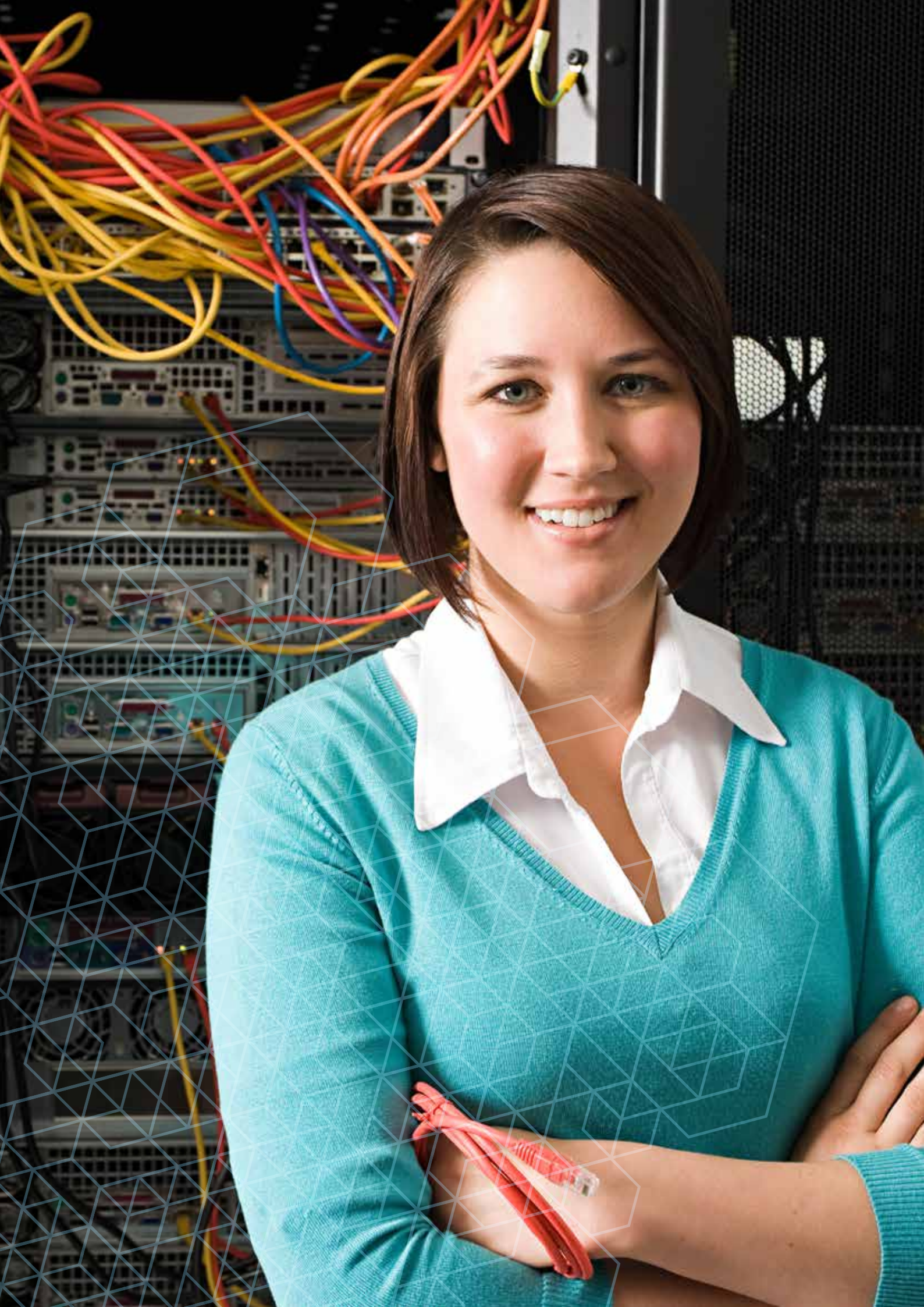

All-Island Ten Year

Transmission Forecast
Statement **2016**

8. Transmission Capability for New Demand



8. Transmission System Capability for New Demand¹

This chapter presents demand opportunity analysis which assesses the capability of the existing and planned transmission system to accommodate increased demand. Opportunities for further demand connections in Ireland and Northern Ireland are discussed.

Analysis of the 2021 transmission system indicates that all regions studied across the island have opportunities to connect demand at 275, 220 and 110 kV stations.

There continues to be a significant volume of enquiries and applications for the connection of data centres in the Dublin region (see Chapter 3). Due to this, we added a new section (Section 8.3) to TYTFS 2015 which presented a qualitative approach describing demand opportunities in the Dublin area. We also include this approach in this TYTFS. The qualitative analysis of Dublin indicates that there is limited network capacity available for the connection of data centres.

8.1 Transmission System Demand Capability Obligations

This chapter of the TYTFS is published in order to meet the requirements of EirGrid's Section 38 of the 1999 Electricity Act and Condition 33 of SONI's licence.

The analysis illustrated in Chapter 8 is presented to provide a high-level indication of transmission network capacity for developers. Results from demand capability studies are based on a specific set of assumptions (see Chapter 6) which may be subject to change. Developers wishing to connect to the transmission system will therefore require further detailed studies.

The TYTFS is not intended to have any legal effect on the negotiation of contractual terms for transmission system connections. Before making any commercial decisions developers should contact us for discussions on their proposed developments.

8.2 All-Island Transmission System Capability for New Demand

As detailed in Chapter 6, the transmission system's capability to accommodate new demand is assessed using demand opportunity analysis. The study was performed for 2021 winter and summer peaks.

Data used for the demand opportunity analysis is based on the best available information at the July 2016 data freeze date. The results of the demand opportunity analysis presented in this chapter are based on the following assumptions:

- Year 2021 demand forecast was used (see Appendix C)
- Only transmission reinforcements with capital approval (Ireland) which are planned to be completed by 2021 were included in the analysis (see Chapter 2)
- Planned generation up until 2021 was included in the analysis (see Appendix D)
- Variable generation cannot be relied upon to serve demand. As such, variable generation local to the test station was switched out.
- The 2021 transmission system was assessed for the loss of a single transmission asset (N-1), maintenance-trip (N-1-1) and loss of a double transmission circuit (N-DC, Northern Ireland) contingences.

We analysed twenty-four 110 kV stations throughout Ireland and Northern Ireland. In response to stakeholder feedback, we also analysed ten 275 kV stations and four 220 kV stations. These stations were included to help identify potentially suitable locations for major industrial load centres with large power requirements. The stations examined and their accompanying results are shown in Figure 8-1.

1. Information for potential Demand Connections can be accessed at the following addresses: http://www.eirgridgroup.com/_/uid/463e7512-d115-4d94-b1ab-79b8cb366f73/index.xml and <http://www.soni.ltd.uk/Customers/howconnected/>

It should be noted that demand opportunity is tested at each station on an individual basis. As such, the opportunities presented are not cumulative. If new demand connects in an area that is currently shown to have capacity, this will then use up some or all of the available capacity in that area.

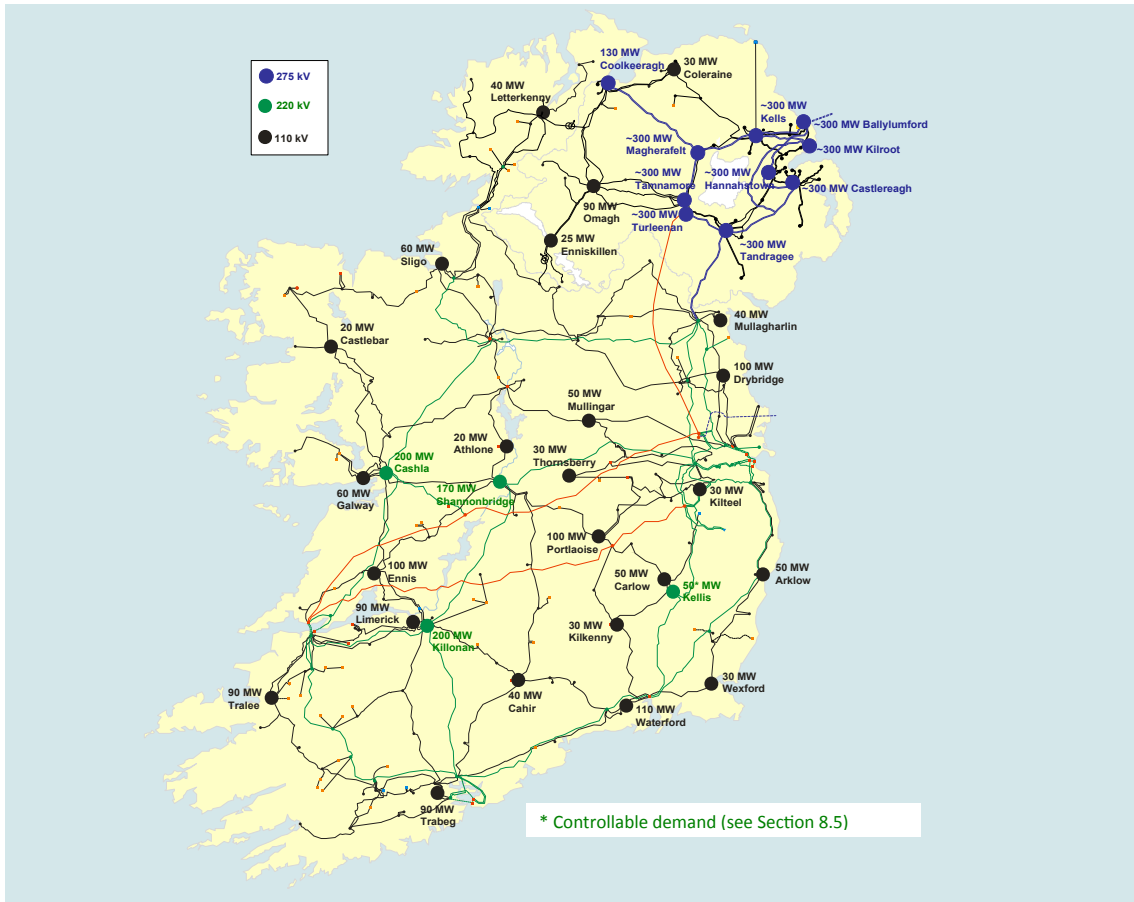

Figure 8-1 Capability for Additional Demand at 275 kV, 220 kV and 110 kV Stations (given to the nearest 10MW)

As a general rule, demand opportunity at a particular station would tend to reduce over time. This is due to normal demand growth using up available capacity. Yet, in many cases demand opportunities can improve as a result of planned transmission system or generation developments.

The results of the analysis are presented on a regional basis below. Each figure is accompanied by a description of factors restricting demand opportunity and future network reinforcements which may release demand capacity in the area. The results indicate that in 2021 there will be opportunities at each of the thirty-eight stations² examined.

8.3 Opportunities for New Demand in the Dublin Area

8.3.1 Context

Dublin is the largest load centre on the island of Ireland. We have expanded this section due to the considerable interest and number of enquiries for connection to the grid around Dublin (See Chapter 3 Demand). The volume of enquiries and the uncertainty of their final power requirements and interaction require us to make a qualitative assessment of demand opportunities for the future.

2. Twenty-four 110 kV stations, ten 275 kV stations and four 220 kV stations.

The scale of individual demand connection enquiries to the transmission system vary from 20 MW to some possibly extending to over 250 MW in the final stages of development. The enquiries are mainly comprised of data centres that support the information, communications and technology (ICT) infrastructure of large multinational companies.

At present, connected data centres have a combined total capacity of approximately 290 MVA. This includes connections to the transmission and distribution systems. Beyond this, there continues to be significant interest in connecting other data centres to the grid in Ireland. There is currently around 870 MVA of data centres either contracted to connect or in the EirGrid and ESB Networks connection offer processes.

In addition to this, there continues to be on-going enquiries regarding further data centre applications. To put this in context, the current winter peak demand on the all-island transmission system is approximately 6,500MW. If all applicants currently being processed were to connect, the data centre load would sum to around 17% of the all-island system peak demand.

Loads of this scale typically require connections to the 220 kV and 110 kV network. EirGrid is working with customers and the distribution system operator, ESB Networks, to meet their individual needs and to ensure optimal network development and solutions.

8.3.2 The Dublin Network

The diagram in Figure 8-2 represents the 220 kV backbone transmission system in the greater Dublin area in 2021. There also exists a 110 kV network in the Dublin area however, for clarity we have not shown it in Figure 8-2.



Figure 8-2: Dublin area 220kV transmission system

Electricity is supplied within Dublin via a 220 kV network arranged in a figure of eight. A combination of operational arrangements and network devices can create open points that effectively divide the Dublin 220 kV network into North and South rings as required.

This network configuration is primarily used to maintain fault currents at safe levels should a network fault occur. It also prevents excessive power flows through the Dublin region. Dublin is then fed via the underlying 110 kV distribution infrastructure which is mainly arranged radially from transmission bulk supply point (BSP) interface stations (220/110 kV).

The larger Dublin power stations are located at Huntstown, which is made up of two separate generators, in North Dublin and one each at Irishtown and Shellybanks in Dublin Bay. The combined capacity of these four stations is approximately 1,600 MW. The 500 MW East West Interconnector also feeds into Woodland 400 kV station on the periphery of North Dublin.

Analysis is carried out to ensure compliance with the Transmission System Security and Planning Standards (TSSPS) for all new connections to the transmission system.

This ensures the co-ordinated development of a reliable, efficient, and economical system for transmission system users. EirGrid must ensure the performance requirements of the TSSPS are met. For example, the thermal capacity limits of equipment must be maintained for all operating conditions.

To ensure the optimised, efficient and economic development of the network, EirGrid aims to make maximum use of existing assets. This can be achieved by using generation output to help offset power flows on the network and avoid the need for reinforcement. The cost of using generation in this way is compared to the cost of new network reinforcements.

There are primarily three limitations that can restrict the availability of transmission capacity in Dublin:

- (1) Limitations at the 220/110 kV interface stations, these can include restrictions due to the 220/110 kV transformers or spatial constraints;
- (2) Power flow limitations on local transmission circuits within Dublin; and
- (3) Limited capacity on circuits outside Dublin in terms of facilitating large power flows across the transmission network.

Generation dispatch is critical in assessing the capability of the network and can have a significant impact on (2) and (3) above, especially in the case of Dublin.

The power delivered to Dublin demand centres can originate from power sources located within or outside Dublin or a combination of both. This is dependent on wholesale electricity market generation costs in the Single Electricity Market (SEM) as well as network or system issues.

Recently there has been a tendency for increased high power flows into Dublin from generation located outside the area. This is a result of the increased penetration of wind generation and the commissioning of other high merit order generators outside of Dublin.

8-4

In some instances these high power flows from outside the Dublin area can be reduced when power is generated inside Dublin. This could release network capacity for transmission users. However, as more demand has sought to connect in Dublin our analysis indicates an increased requirement for existing generation to offset high power flows into, and around, Dublin.

8.3.3 Dublin Transmission Development Plans

Figure 8-3 below describes the areas of focus for demand connections in Dublin and the scale of interest in each zone. The connections fall into three zones North, West and South Dublin.

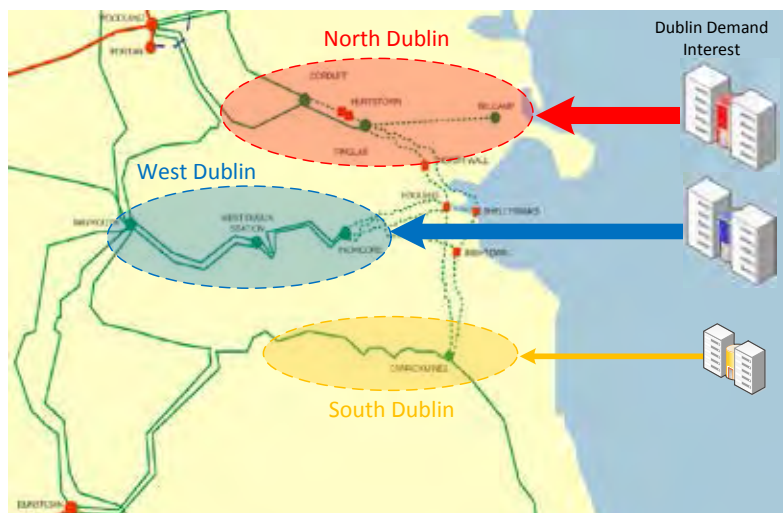

Figure 8-3: Dublin potential demand connections

Each zone is described below with consideration given to potential levels of demand connection, existing transmission infrastructure, transmission network projects and lead times.

Should the reader require more detailed transmission network project information please read our grid development strategy “Your Grid, Your Tomorrow.” published in January 2017³, the current Transmission Development Plan⁴ and the latest Associated Transmission Reinforcement (ATR) update⁵.

The project tables in the following sections provide a brief description of the projects, the estimated lead-time and the project’s status. Project status is classified into three categories: ‘pre-planning’, ‘planning’ and ‘approved’. ‘In construction’ and ‘complete’ are subsets of the approved category. A description of each project status category is given in Appendix F, Section F.1.

8.3.4 North Dublin

North Dublin includes two 220/110 kV interface stations at Corduff and Finglas with another planned at Belcamp. The level of interest for connection in North Dublin is the highest of all Dublin areas.

A number of transmission projects are in place to increase the network capacity and security of supply in this area. They are summarised in Table 81 below.

Table 8-1: North Dublin projects

Project Name	Project Description	Status	Estimated Delivery Date
Maynooth - Woodland	220 kV line refurbishment	Approved	2017
Cloghran-Corduff	New 110 kV cable	Complete	2016
Belcamp	New 220/110 kV station	Approved	2018
Finglas	Uprate/Modify 220/110 kV station	Approved	2018
Belcamp Phase 2	Additional 220/110 kV transformer and second circuit	Pre-planning	2022

The transmission projects described above are sufficient to meet the current level of demand connections either contracted or in the EirGrid and ESB Networks connection offer processes. However, assuming all applications progress to connection, additional transmission and/or generation capacity, demand side response and/or storage will be required to accommodate further demand increases and ensure continued security of supply.

Facilitating further high levels of demand connections will require additional network reinforcement in the area. This could be in the form of increased network connectivity with Woodland 400 kV station for example. Typically, such major projects delivering additional network capacity have significant lead times (five to eight years) which are dependent on the chosen technology.

3. <http://www.eirgridgroup.com/the-grid/irelands-strategy/>
 4. The latest TDP can be found on the EirGrid website <http://www.eirgridgroup.com/>
 5. The latest ATR update can be found on the EirGrid website <http://www.eirgridgroup.com/>

8.3.5 West Dublin

West Dublin includes two main 220/110 kV interface stations at Inchicore and Poolbeg with another planned at Castlebagot⁶ station. These stations are supported by the Maynooth 220 kV station on the outer rim of the Dublin region. The level of interest for connection in the West Dublin area is very high, second only to North Dublin.

A number of transmission projects are in place to increase the network capacity and security of supply in this area. They are summarised in Table 8-2 below.

Table 8-2: West Dublin projects

Project Name	Project Description	Status	Estimated Delivery Date
Inchicore-Maynooth	Uprate 220 kV No.1 & No.2 lines	Complete	2015
Maynooth-Ryebrook	Uprate 110 kV line	Complete	2015
Poolbeg	Installation of 100 Mvar reactive support	Approved	2017
Ryebrook-Corduff	Uprate 110 kV line	Approved	2017
Ryebrook	Refurbish 110 kV station	Approved	2017
Castlebagot	New 220/110 kV station	Approved	2019
Inchicore	Uprate/Modify 220/110 kV station	Approved	2022
Dunstown -Woodland Corridor Reinforcement	Increase capacity between the Dunstown and Woodland 400 kV stations	Pre-planning	2024
Maynooth	Uprate/Modify 220/110 kV station	Pre-planning	2025

It is anticipated that this area of Dublin will have a moderate level of network capacity upon completion of the new Castlebagot 220 kV station.

It will facilitate connections either contracted or in the EirGrid and ESB Networks connection offer processes. There will also be some further network capacity available to transmission network users beyond what is currently contracted or in the EirGrid and ESB Networks connection offer processes.

After the construction of the new Castlebagot 220 kV station, it is expected that additional network capacity at Inchicore 220 kV station may be available. This is due to the transferring of some existing demand at Inchicore to the new Castlebagot 220 kV station.

6. Formerly known as West Dublin 220/110 kV station.

8.3.6 South Dublin

South Dublin includes one main 220/110 kV interface station at Carrickmines. Carrickmines is connected at 220 kV to Dunstown 400 kV station and Arklow 220 kV station. The level of interest for connections in South Dublin area is lower in comparison to the interest in North and West Dublin.

A number of transmission projects are in place to increase the network capacity and security of supply in this area. They are summarised in Table 8-3 below.

Table 8-3: South Dublin projects

Project Name	Project Description	Status	Estimated Delivery Date
Dunstown	New 400/220 kV 500 MVA transformer	Complete	2015
Carrickmines	New 220/110 kV 250 MVA transformer & GIS development	Approved	2017

Considering the South Dublin transmission projects and the level of connection enquiries, this area of Dublin has a moderate level of network capacity available to facilitate connections either contracted or in the EirGrid and ESB Networks connection offer processes. Indeed there is further network capacity available to transmission network users beyond these connections.

8.3.7 Impact of Generation & Flexible Demand on North, West and South Dublin

As described in Chapter 7 there is currently a small generation deficit in the Dublin region which has the potential to increase. If additional generation was to locate in the Dublin area this would generally improve the network capacity available for transmission system users in North, West and South Dublin zones.

However, the specific location of any proposed additional generation would have to be assessed to fully understand its full impact on the network.

Similarly, if major demand customers can demonstrate a certain level of demand side flexibility during low probability system events this would also improve the capability of the network to accommodate further demand increases.

8.3.8 Looking Forward

EirGrid recently published an updated Grid Development Strategy for the long-term development of the network. In the strategy paper⁷, we explain the role of electricity transmission infrastructure in supporting new investments and jobs as well as ensuring competitiveness by offering cost-effective power capacity.

The strategy puts forward a number of major projects to upgrade the transmission network. The Regional Solution (see Chapter 2) and Dunstown – Woodland corridor reinforcement projects have many system benefits, which include providing additional network capacity and improving security of supply for the eastern side of Ireland.

The Regional Solution project involves a new circuit across the Shannon Estuary and the installation of series compensation equipment on the 400 kV circuits that extend from Moneypoint 400 kV power station in the West of Ireland towards Woodland and Dunstown 400 kV stations located on the western outskirts of Dublin.

7. <http://www.eirgridgroup.com/the-grid/irelands-strategy/>

This project will greatly enhance the capability of the existing 400 kV circuits to transfer bulk power generated in the South-West and West to Dublin and other demand centres in the East as illustrated by the green arrows in Figure 8-4.

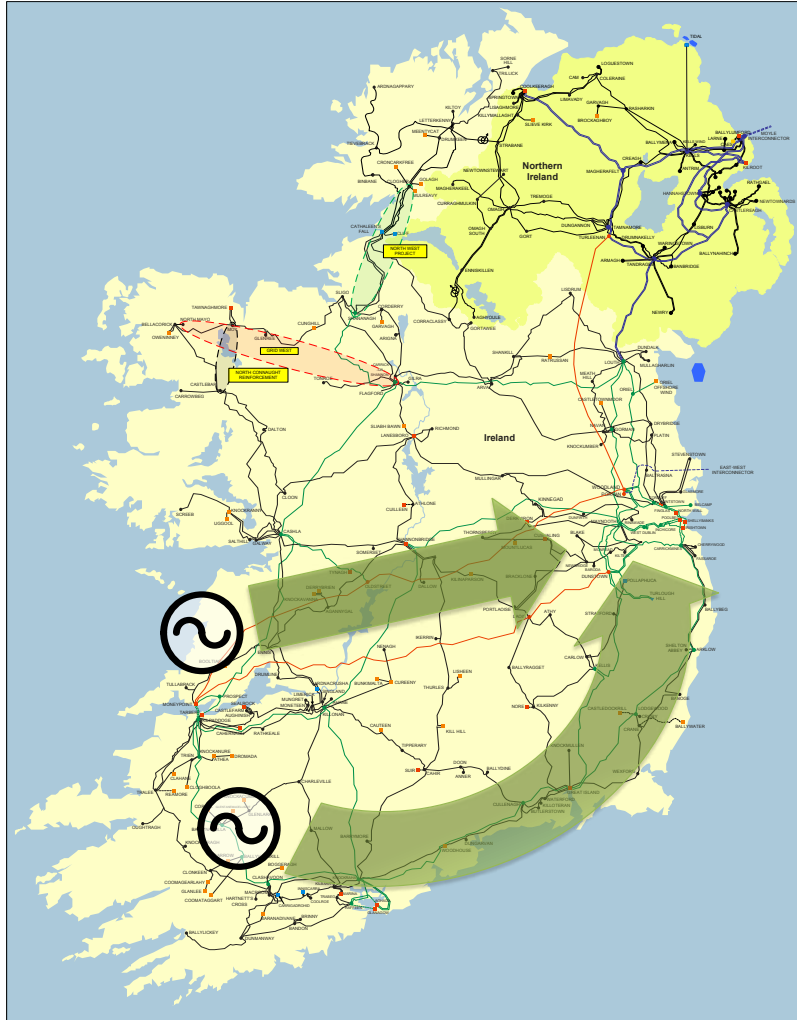

Figure 8-4: Transfer of power generated in the West and South-West regions to the East

The Dunstown – Woodland corridor reinforcement is at an early point in the project life-cycle. The project will increase the strength of the link between two 400 kV stations at Dunstown and Woodland. This will provide benefit by reducing power flows that pass through the Dublin transmission 220 kV network, thus releasing network capacity on several key constrained circuits.

To maintain system stability and facilitate significant inter-regional power flows we are also developing a number of voltage support solutions across Ireland.

8.3.9 Summary

Depending on the location, number and scale of projects that materialise and the capacity limitations of the existing network in Dublin, new transmission solutions will be required to strengthen the grid. These solutions are now under initial investigation and could vary from short to longer lead-time developments.

We continue to apply a strategic approach to network development and we are continuously considering the approach to the level of demand enquires. Our strategic approach will take account of the following:

- Companies developing data centres operate in a rapid and dynamic environment. Their business requires connection timescales that are short relative to time taken for transmission reinforcement. Most are considering being operational within two to three years and growing their power usage rapidly thereafter.
- We are working to understand the needs of these developers and their impact in terms of our grid development strategy. We are publishing information on the system adequacy, grid needs and opportunities to ensure transparency so that the impacts of this sector and its developments are known.
- To date, we have been able to facilitate connections for developers who have applied. We will continue to examine innovative solutions and technologies in response to future requests. However, as interest in connecting additional demand has developed into contracted connections, the available capacity on the existing transmission network for further large scale demand connections has largely been depleted.

It is advised that any potential new demand consumers contact EirGrid early so that we can work jointly to achieve a connection solution. This facilitates the optimisation of transmission reinforcements so that the requested capacity can be delivered.

It is also recommended to locate any new large scale data centres in close proximity to existing 220 kV stations or circuits as this may help expedite the provision of a suitable connection.

As a prudent system operator, EirGrid ensures that adequate spare capacity for regional and national demand growth is available, while avoiding unnecessary over investment in grid capability. Therefore a balance is maintained between the reasonable expectations placed on the network and the cost of grid development and maintenance. Delivering an efficient transmission grid requires that this balance of investment is maintained.

8.4 Transmission System Capability for New Demand in Ireland

Demand opportunities available on an Ireland regional basis are discussed in Sections 8.4.1 to 8.4.5. Results presented in Section 8.4 are based on the assumptions detailed in Chapter 6.

8.4.1 Opportunities for New Demand in the Midlands and West

The demand opportunities available in the Midlands and West are shown in Figure 8-5. It is shown that there are potential demand opportunities available for new customers at all stations examined in the region. In particular, Cashla and Shannonbridge 220 kV stations would be suitable connection points for major industrial load centres. Both of these stations are capable of accommodating in the order of 200 MW without additional network reinforcements.

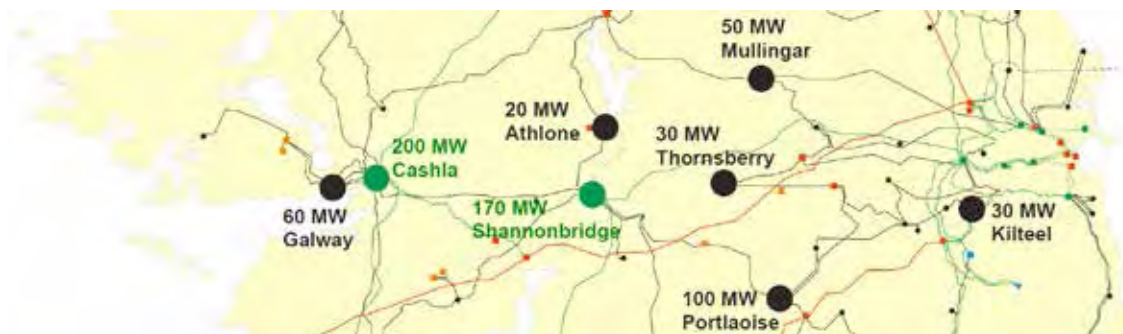

Figure 8-5 Capability for Additional Demand in Midlands and West Regions

8.4.2 Opportunities for New Demand in the North-East

The demand opportunities available for the North-East region are shown in Figure 8-6. It is shown that there are potential demand opportunities available for industrial customers at all stations examined in the region. The delivery of the North-South interconnector aids demand opportunity in the North-East. The North-South interconnector provides a route for large power transfers to flow between Northern Ireland and Ireland via the North-East region of Ireland. The North-South interconnector will benefit potential demand customers connecting in this region by releasing more capacity on the underlying 110 kV network.

Potential overloading of the Louth – Mullagharlin 110 kV line is responsible for limiting the opportunity at Mullagharlin (40 MW). The overload occurs during winter and summer peaks for single circuit outage conditions. This is a local issue as only two circuits supply the load at Mullagharlin. Drybridge (100 MW), however, is more interconnected with four circuits supplying the station.

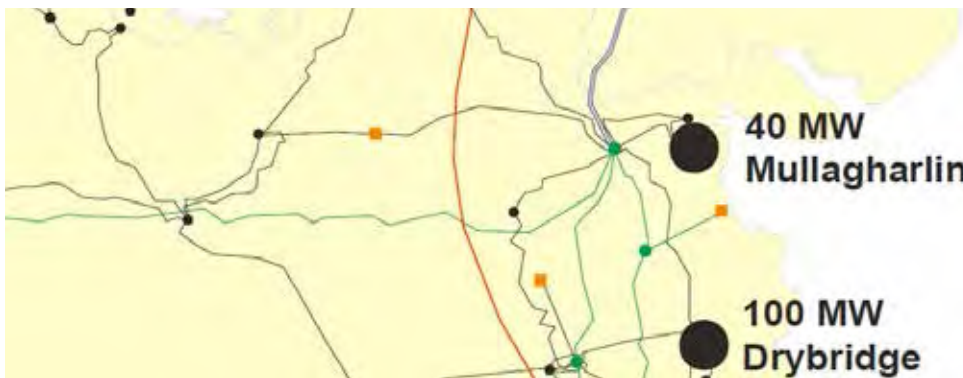

Figure 8-6 Capability for Additional Demand in North-East Region

8.4.3 Opportunities for New Demand in the North-West

The demand opportunities available for the North-West region are shown in Figure 8-7. It is shown that there are potential demand opportunities available for industrial customers at all stations examined in the region. The potential demand opportunity at Castlebar is 20 MW. Analysis has shown that the Castlebar – Cloon 110 kV line could overload as power tries to flow to Castlebar under certain maintenance-trip scenarios (see Chapter 6). The uprate of Castlebar – Cloon 110 kV line would allow for more demand opportunity at Castlebar.



Figure 8-7 Capability for Additional Demand in North-West Region

8.4.4 Opportunities for New Demand in the South-East

The demand opportunities available for the South-East region are shown in Figure 8-8. It is shown that there are potential opportunities available for industrial customers at all stations examined in the region.

The demand opportunity at Kellis 220 kV station is limited to 50 MW due to the maintenance-trip scenario (see Chapter 6) where both 220 kV lines supplying Kellis are assumed to be out of service. This scenario means that demand at Kellis 220 kV station must be supplied by the underlying 110 kV network, which does not have the capacity to carry as much power as the 220 kV network.

However, should a demand facility wishing to connect at Kellis 220 kV station implement a ‘Controllable Demand’ strategy there would be potential for much greater capacity of demand to connect to Kellis 220 kV. This is explained further in Section 8.5 on ‘Controllable Demand’.

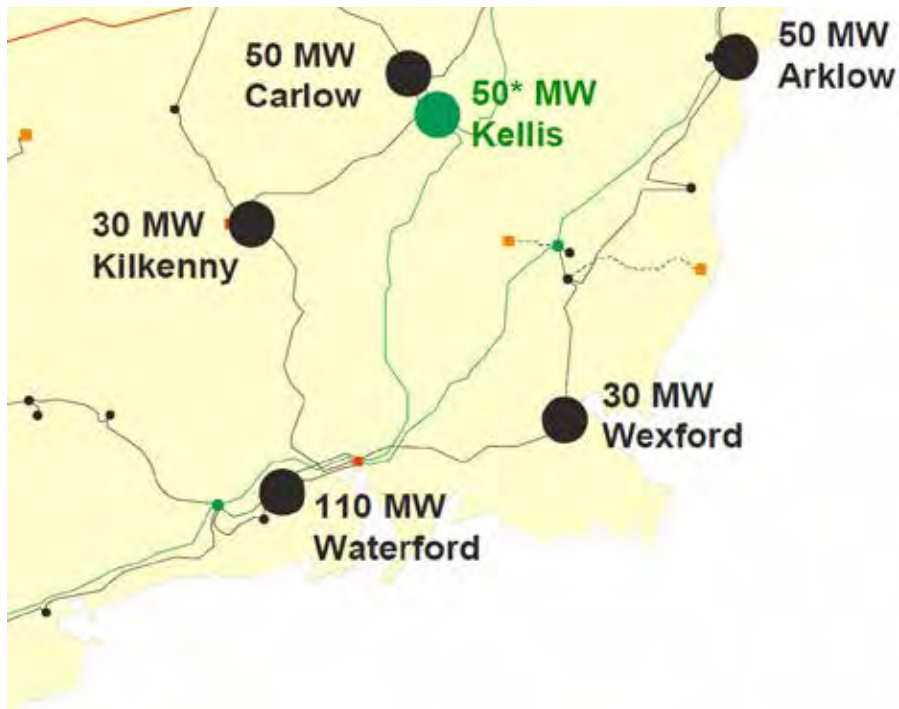

Figure 8-8 Capability for Additional Demand in the South-East Region

8.4.5 Opportunities for New Demand in the South-West

The demand opportunities available for the South-West region are shown in Figure 8-9. It can be seen that there are potential opportunities available for industrial customers at all stations examined in the region.

In particular the Killonan 220 kV station would be a suitable connection point for a major industrial load centre, with the capability of accommodating in excess of 200 MW without additional network reinforcements.

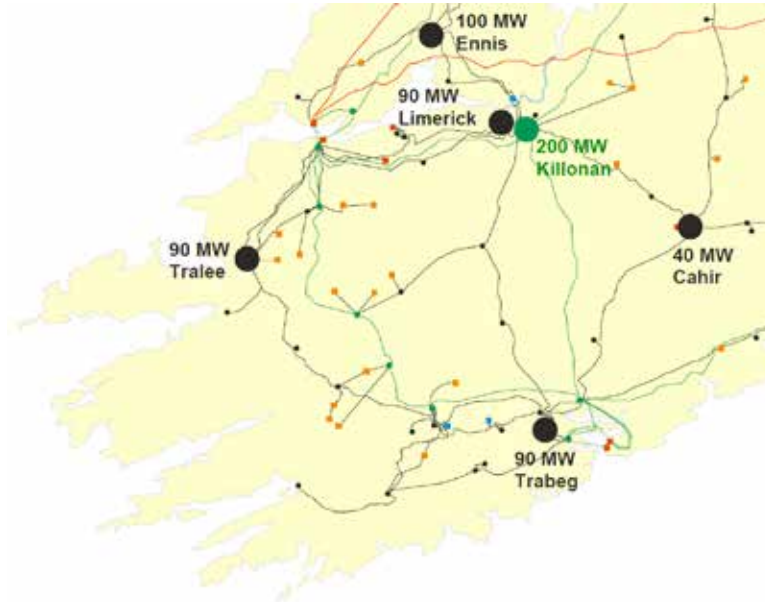

Figure 8-9 Capability for Additional Demand in South-West Region

8.5 Controllable Demand

Kellis 220 kV station is a good example to demonstrate the potential to increase the assessed capacity of a station through the concept of ‘controllable demand’. In the case of Kellis 220 kV station, demand opportunity is limited to 50 MW due to a maintenance-trip scenario where both 220 kV lines supplying Kellis 220 kV station are assumed to be out of service. The next limiting scenario after the outage of both 220 kV lines supplying Kellis would allow for much greater demand opportunity at Kellis 220 kV station.

Maintenance-trip contingency planning forms part of a suite of contingencies considered by EirGrid for prudent planning of the transmission system. However, it is also recognised in the Transmission System Security and Planning Standards (TSSPS) that exposure to maintenance-trip events is much less than the other contingency events considered.

This means that under certain circumstances, potential demand customers may enter an agreement with EirGrid to connect a higher level of demand at a particular station, on the condition that the customer would reduce load if certain contingencies occurred.

Using Kellis 220 kV station as an example, a potential demand customer may enter an agreement with EirGrid to connect 200 MW of load at Kellis, but drop to 50 MW if either of the 220 kV lines supplying Kellis are out of service.

It should be noted that Kellis has been used as an example. Depending on reliability requirements, this type of agreement may not be suitable for all types of demand facilities or locations. We encourage any potential customers to discuss the possibility of controllable demand with us at an early stage of project planning and development.

8.6 Transmission System Capability for New Demand in Northern Ireland

Section 8.6.1 discusses the demand opportunities available in the Eastern region of Northern Ireland. Section 8.6.2 discusses the demand opportunities available in the Western region. These results are based on the assumptions detailed in Chapter 6.

8.6.1 Opportunities for New Demand in East of Northern Ireland

The demand opportunities available in the Eastern region are shown in Figure 8-10.



Figure 8-10 Capability for Additional Demand (MW) in the East of Northern Ireland

It can be seen that there are potential opportunities available for industrial customers at all stations examined in the region. Each of the 275 kV stations in the East of Northern Ireland would be suitable connection points for major industrial load centres. Each of these stations is capable of accommodating in the order of 300 MW⁸ of additional demand without additional network reinforcements.

8.6.2 Opportunities for New Demand in West of Northern Ireland

The demand opportunities available for the West of Northern Ireland are shown in Figure 8-11.



Figure 8-11 Capability for Additional Demand in the West of Northern Ireland

8. Please note that the demand opportunities results are not cumulative. Each station is assessed individually, taking account of forecast demand growth only at stations outside of the test node. These figures are indicative only, with further detailed assessment of each station required. Customers considering connecting demand to the NI transmission system are advised to contact SONI as early in the project as possible.

It can be seen that there are potential opportunities available for industrial customers at all stations examined in the region. It should be noted that the North-West of Northern Ireland requires specific assessment in line with the TSSPS (see Chapter 6). As the North-West is connected by a single double circuit 275 kV spur, an N-1-1 contingency is performed as a credible contingency.

Under N-1-1 the demand capability of Coolkeeragh is limited to 130 MW. This is under the following conditions:

- The loss of the Coolkeeragh-Magherafelt 275 kV double circuit;
- Coolkeeragh steam and gas units are out on maintenance; and
- Coolkeeragh G8 is dispatched.

Enniskillen 110 kV station represents the lowest capability of the nodes assessed. Enniskillen 110 kV is connected to Omagh South station via two 110 kV circuits. The loss of one of these circuits creates a thermal overload on the other. This limits demand connection capability.

8.7 How to Use the Information for Demand

Although not every station was considered, the results presented can be regarded as a guide to opportunities at other stations in the same area.

Customers wishing to use the demand opportunity results described in this chapter when considering where to connect should follow these steps:

1. Consult the maps in Appendix A to find the nearest transmission station to the proposed development. Also, the nearest station for which opportunity has been assessed (Sections 8.4 and 8.6) should be identified, where it differs from the nearest transmission station.
2. The anticipated demand growth at the relevant station can be obtained from the demand forecasts presented in Appendix C. The transmission system is being planned to meet this level of demand increase.
3. Review assumptions in Chapters 2 to 4 and consider the impact of changes to the transmission system since the analysis was carried out.
4. Consult with EirGrid and SONI on the proposed location as early as possible as well as consulting the EirGrid application process⁹ and SONI application process¹⁰.

Potential demand customers should not be discouraged by choosing a site in which there appears to be a lack of transmission system capacity. Early consultation with us is encouraged so that we can work jointly to explore options relating to any potential proposals and enable timely decision making.

9. <http://www.eirgridgroup.com/customer-and-industry/becoming-a-customer/>

10. <http://www.soni.ltd.uk/Customers/howconnected/>

All-Island Ten Year

**Transmission Forecast
Statement** **2016**

Appendix A

Appendix A: Maps and Schematic Diagrams

Appendix A contains geographical maps of the All-Island Transmission System and short bus codes for every transmission voltage node on the island. Geographical maps are presented illustrating the All-Island Transmission System as it exists in 2016 and as planned for 2025.

A.1 Network Maps

This section includes two network maps:

- Figure A-1 is a map of the existing All-Island Transmission System as at July 2016;
- Figure A-2 is a map of the planned All-Island Transmission System in 2025

Note: There are a number of network reinforcement projects that do not have a finalised reinforcement solution. Solutions are presented in the map A-2. The solutions that will be used for these projects have not yet been finalised. They are shown on the Transmission System Map as a transparent bubble.

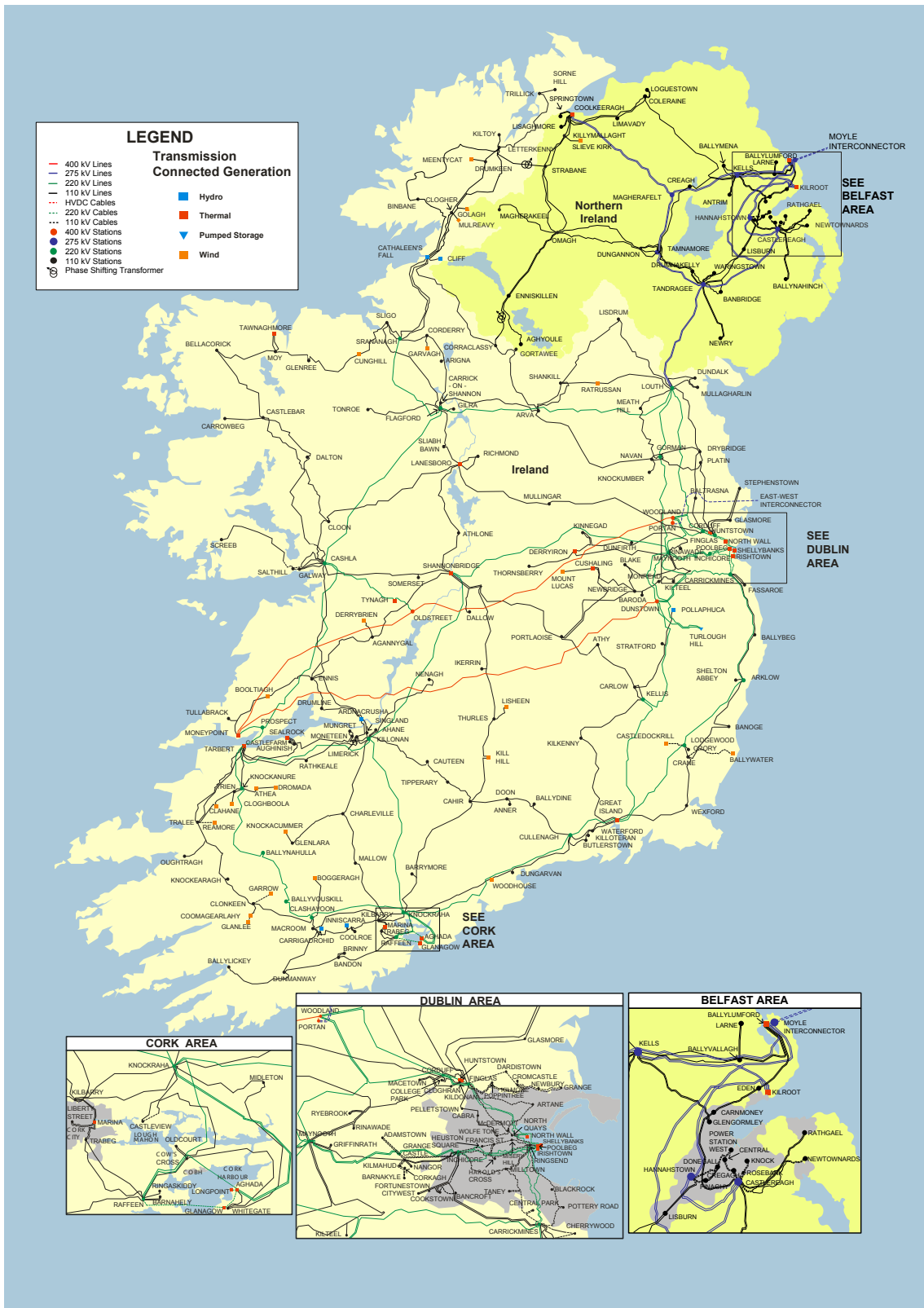

Figure A-1 Transmission System 400 kV, 275 kV, 220 kV and 110 kV - Year 2016

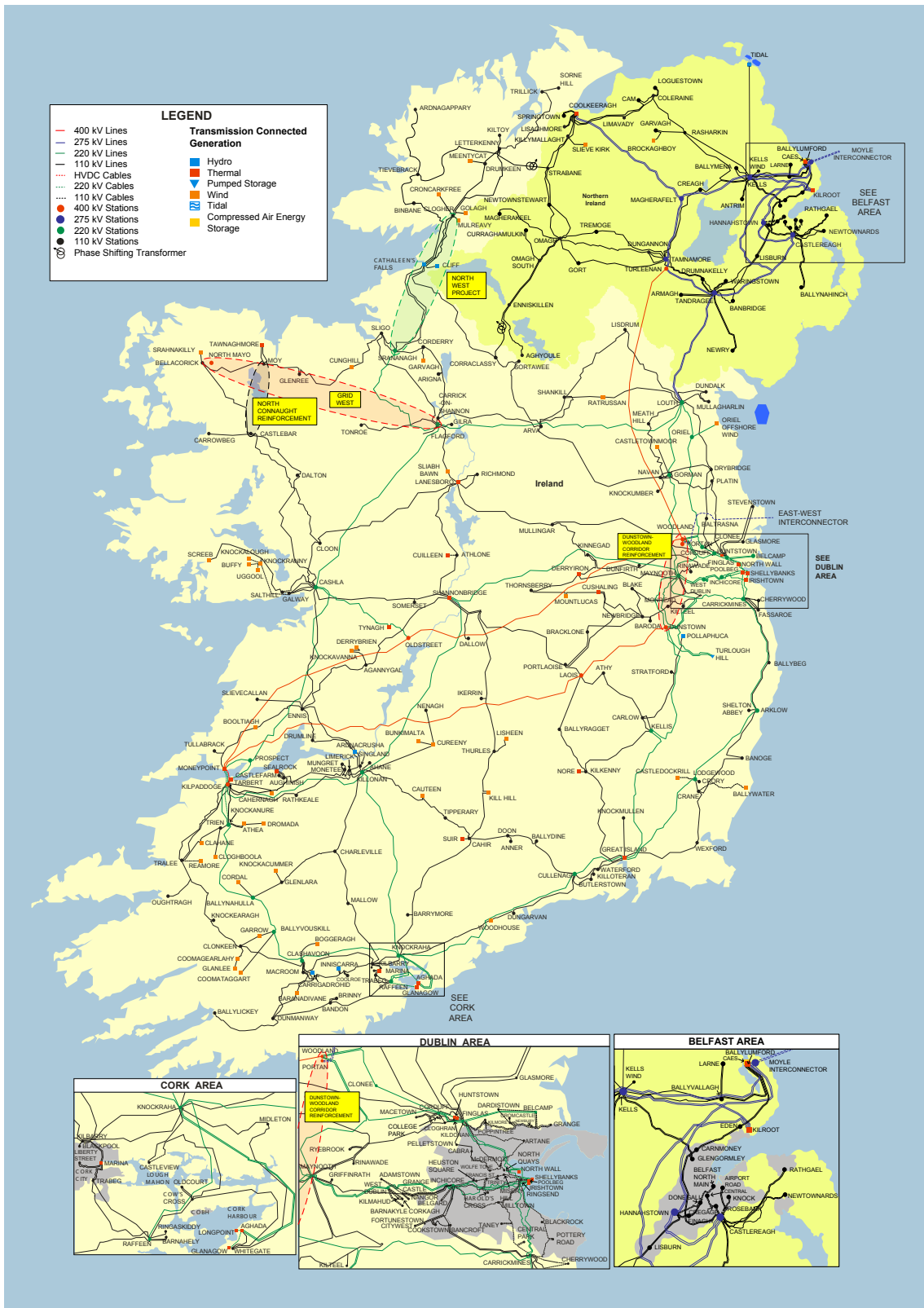

Figure A-2 Planned Transmission System 400 kV, 275 kV, 220 kV and 110 kV - As at Year End 2025

A.2 Short Bus Codes

The following table associates full station names with the two or three letter codes used in the schematic diagrams in Section A.3, in the tables in Appendices B and C, and the power flow diagrams in Appendix H. Stations in Northern Ireland and Ireland with the same three letter bus code are distinguished with (N) for Northern Ireland and (I) for Ireland.

Table A-1 Short Bus Codes

Short Bus Code	Full Name	Short Bus Code	Full Name	Short Bus Code	Full Name
AA	Ardnacrusha	BEG	Ballybeg	BWR	Ballywater
AD	Aghada	BGD	Belgard Road	BY	BallaKelly
ADM	Adamstown	BGH	Boggeragh	BYC	Ballycronan More (Moyle)
AGH	Aghyoule Main	BGT	Ballyragget	BYH	Ballynahulla
AGL	Agannygal	BIN	Binbane	CAB	Cabra
AGY	Ardnagappary	BK	Bellacorick	CAE	CAES
AHA	Ahane	BKM	Bunkimalta	CAH	Cahir
AIR	Belfast - Airport Road Main	BKY	Barnakyle	CAM	Cam Cluster
ANR	Anner	BLC	Belcamp	CAR	Belfast - Carnmoney Main
ANT	Antrim Main	BLA	Blackrock	CAS	Castlereagh Main
ARI	Arigna	BLI	Ballylickey	CBG	Carrowbeg
ARK	Arklow	BLK	Blake	CBL	Cloghboola
ARM	Armagh Main	BLP	Blackpool	CBR	Castlebar
ART	Artane	BMA	Ballymena Mesh (Rural)	CD	Carrigadrohid
ARV	Arva	BMA	Ballymena SWBD (Town)	CDK	Castledockrill
ATE	Athea	BNH	Ballynahinch Main	CDL	Cordal
ATH	Athlone	BNM	Belfast - Belfast North Main	CDU	Corduff
ATY	Athy	BOG	Banoge	CDY	Corderry
AUG	Aughinish	BOL	Booltiagh	CEN	Belfast - Belfast Central Main
BAL	Baltrasna	BPS	Ballylumford Power Station	CF	Cathaleen's Fall
BAN (I)	Bandon	BRA	Bracklone	CFM	Castlefarm
BAN (N)	Banbridge Main	BRI	Brinny	CGL	Coomagearlahy
BAR	Barrymore	BRO	Brockaghboy Main	CH	Cahernagh
BCM	Ballycummin	BRY	Barnahely	CHA	Charleville
BCT	Bancroft	BUF	Buffy	CHE	Cherrywood
BDA	Baroda	BUT	Butlerstown	CHR	Cahernagh
BDN	Ballydine	BVG	Ballyvallagh	CKG	Corkagh
BDV	Barnadivane	BVK	Ballyvouskill		

Table A-1 Short Bus Codes

Short Bus Code	Full Name	Short Bus Code	Full Name	Short Bus Code	Full Name
CKM	Carrickmines	CUL	Cullenagh	FNT	Finnstown
CKN	Clonkeen	CUN	Cunghill	FRN	Francis Street
CL	Cliff	CUR	Cureeny	FTT	Fortunestown
CLA	Clashavoon	CUS	Cushaling	GAE	Glanlee
CLE	Clonee	CVW	Castleview	GAL	Galway
CLG	Cloghran	DAL	Dallow	GAR (I)	Garvagh
CLH	Clahane	DDK	Dundalk	GAR (N)	Garvagh Cluster
CLN	Cloon	DER	Derryiron	GCA	Grange Castle
CLO	Clogher	DFR	Dunfirth	GGO	Glanagow
CLW	Carlow	DGN	Dungarvan	GI	Great Island
CMK	Curraghmulkin Cluster	DLN	Derrylyn	GIL	Gilra
COL (I)	College Park	DLT	Dalton	GLA	Glasmore
COL (N)	Coleraine Main	DMY	Dunmanway	GLE (I)	Glenlara
COO	Cookstown	DON	Belfast - Donegall Main	GLE (N)	Belfast - Glengormley Main
COR	Corraclassy	DOO	Doon	GLR	Glenree
COS	Carrick-on-Shannon	DRM	Drumkeen	GLT	Glentanemacelligot
COW	Cow Cross	DRO	Dromada	GOL	Golagh
CPK	Central Park	DRU (I)	Drumline	GOR (I)	Gorman
CPS	Coolkeeragh Power Station	DRU(N)	Drumnakelly Main	GOR (N)	Gort Cluster
CRA	Crane	DRY	Drybridge	GRA	Grange
CRE	Belfast - Cregagh Main	DSN	Dunstown	GRI	Griffinrath
CRF	Cronacarkfree	DTN	Dardistown	GRO	Garrow
CRG	Creagh Main	DUN	Dungannon Main	GWE	Gortawee
CRM	Cromcastle	DYN	Derrybrien	HAN	Hannastown
CRO	Coolroe	EDE	Eden Main	HAR	Harolds Cross
CRY	Crory	ENN (I)	Ennis	HEU	Heuston Square
CSH	Cashla	ENN (N)	Enniskillen Main	HN	Huntstown
CTG	Coomataggart	FAS	Fassaroe	IA	Inniscarra
CTN	Cauteen	FAS E	Fassaroe East	IKE	Ikerrin
CTR	Castletownmoor	FIN (I)	Finglas	INC	Inchicore
CTY	City West	FIN (N)	Belfast - Finaghy Main	ISH	Irishtown
CUI	Cuilleen	FLA	Flagford	KBY	Kilbarry

Table A-1 Short Bus Codes

Short Bus Code	Full Name	Short Bus Code	Full Name	Short Bus Code	Full Name
KCR	Knockacummer	LIM (N)	Limavady Main	MUL	Mullingar
KDN	Kildonan	LIS (I)	Lisdrum	MUN	Mungret
KEL	Kells Main	LIS (N)	Lisburn Main	NAN (I)	Nangor
KER	Knockearagh	LMR	Lisaghmore Main	NAR	Newtownards Main
KHL	Kill Hill	LOG	Loguestown Main	NAV	Navan
KIN	Kinnegad	LOU	Louth	NBY	Newbury
KKY	Kilkenny	LPT	Longpoint	NEN	Nenagh
KLH	Knockalough	LSE	Laois	NEW (I)	Newbridge
KLM	Kilmore	LSN	Lisheen	NEW (N)	Newry Main
KLN	Killonan	LWD	Lodgewood	NMO	North Mayo
KLS	Kellis	MAC	Macroom	NO	Nore
KLW	Kells Wind Cluster	MAG	Magherafelt	NQS	North Quays
KMT	Killymallaght	MAL	Mallow	NST	Newtownstewart Cluster
KNO	Belfast - Knock Main	MAY	Maynooth	NW	North Wall
KNR	Knockanure	MCD	McDermott	OLD	Oldcourt
KNV	Knockavanna	MCE	Macetown	OMA	Omagh Main
KNY	Knockranny	MEE	Meentycat	OMS	Omagh South Main
KPG	Kilpaddoge	MID	Midleton	ORL	Oriel
KPN	Killinaparson	MHL	Misery Hill	OST	Oldstreet
KPS	Kilroot Power Station	MIL	Milltown	OUG	Oughtragh
KRA	Knockraha	MKL	Magherakeel Cluster	OWN	Oweninney
KTL	Kilteel	MLC	Mountlucas	PA	Pollaphuca
KTN	Killoteran	MLN	Mullagharlin	PB	Poolbeg
KUD	Kilmahud	MON	Monread	PLA	Platin
KUR	Knockumber	MOY	Moy	PLS	Portlaoise
LA	Lanesboro	MP	Moneypoint	POP	Poppintree
LAR	Larne Main	MR	Marina	PRT	Portan
LET	Letterkenny	MRY	Mulreavy	POT	Pottery Road
LIB	Liberty Street	MTH	Meath Hill	PRO	Prospect
LIM (I)	Limerick	MTN	Moneteen	PTN	Pelletstown

Table A-1 Short Bus Codes

















Short Bus Code	Full Name	Short Bus Code	Full Name	Short Bus Code	Full Name
RAF	Raffeen	SLB	Sliabh Bawn	TMN	Tamnamore
RAT (I)	Rathkeale	SLK	Slieve Kirk	TON	Tonroe
RAT (N)	Rathgael Main	SNG	Singland	TRE	Tremoge Cluster
RE	Ringsend	SOM	Somerset	TRI	Trien
REM	Reamore	SOR	Sorne Hill	TRL	Tralee
RIC	Richmond	SPR	Springtown Main	TRN	Trinity
RNW	Rinawade	SRA	Srananagh	TSB	Thornsberry
ROS	Belfast - Rosebank Main	STR (I)	Stratford	TUR	Turleenan
RRU	Ratrussan	STR (N)	Strabane Main	TYN	Tynagh
RSK	Rasharkin Cluster	SUR	Suir	UGL	Uggool
RSY	Ringaskiddy	SVN	Stevenstown	WAR	Waringstown Main
RYB	Ryebrook	TAN	Tandragee	WAT	Waterford
SAL	Salthill	TAW	Tawnaghmore	WDU	West Dublin
SBN	Strabane	TB	Tarbert	WEX	Wexford
SCR	Screeb	TBG	Trabeg	WH	Woodhouse
SH	Shannonbridge	TBK	Tullabrack	WHI	Whitegate
SHE	Shelton Abbey	TH	Turlough Hill	WOL	Wolfe Tone
SHL	Shellybanks	THU	Thurles	WOO	Woodland
SK	Sealrock	TID	Tidal		
SKL	Shankill	TIP	Tipperary		
SKY	Srahnakilly	TIV	Tievebrack		
SLC	Slievecallan	TLK	Trillick		
SLI	Sligo	TLY	Tanley		









A.3 Schematic Diagrams of the All-Island Transmission System

Schematic diagrams of the All-Island Transmission System are included to assist users in understanding the Transmission System and in the identification of the changes outlined in Appendix B. Lines, cables, transformers, station busbars and reactive compensation devices are illustrated in the diagrams. The type of generation (thermal, wind, hydro or solar) at a station is also displayed. Table A-2 indicates the diagram conventions.

The schematic diagram for 2016 highlights the developments due to be completed by July 2016. The schematic diagram for 2025 highlights the developments due to be completed by the end of 2025.

Table A-2 Schematic Legend

Symbol	Network Element Represented
	110 kV circuit
	220 kV circuit
	275 kV circuit
	400 kV circuit
	System Link
	110 kV Busbar
	220 kV Busbar
	275 kV Busbar
	400 kV Busbar
	Busbar with Thermal Generation
	Busbar with Wind Generation (>5 MW)
	Busbar with Hydro Generation
	Busbar with Solar Generation (>5 MW)
	Compressed Air and Energy Storage (CAES)
	Busbar with Wind and Thermal Generation
	Busbar with Wind and Hydro Generation

Symbol	Network Element Represented
	Busbar with Wind and Solar Generation
	Busbar with Tidal Generation
	Capacitor
	Static Var Compensator (SVC)
	Reactor
	Phase Shifting Transformer
	Transformer
	Normally Open Point
	Series Compensation

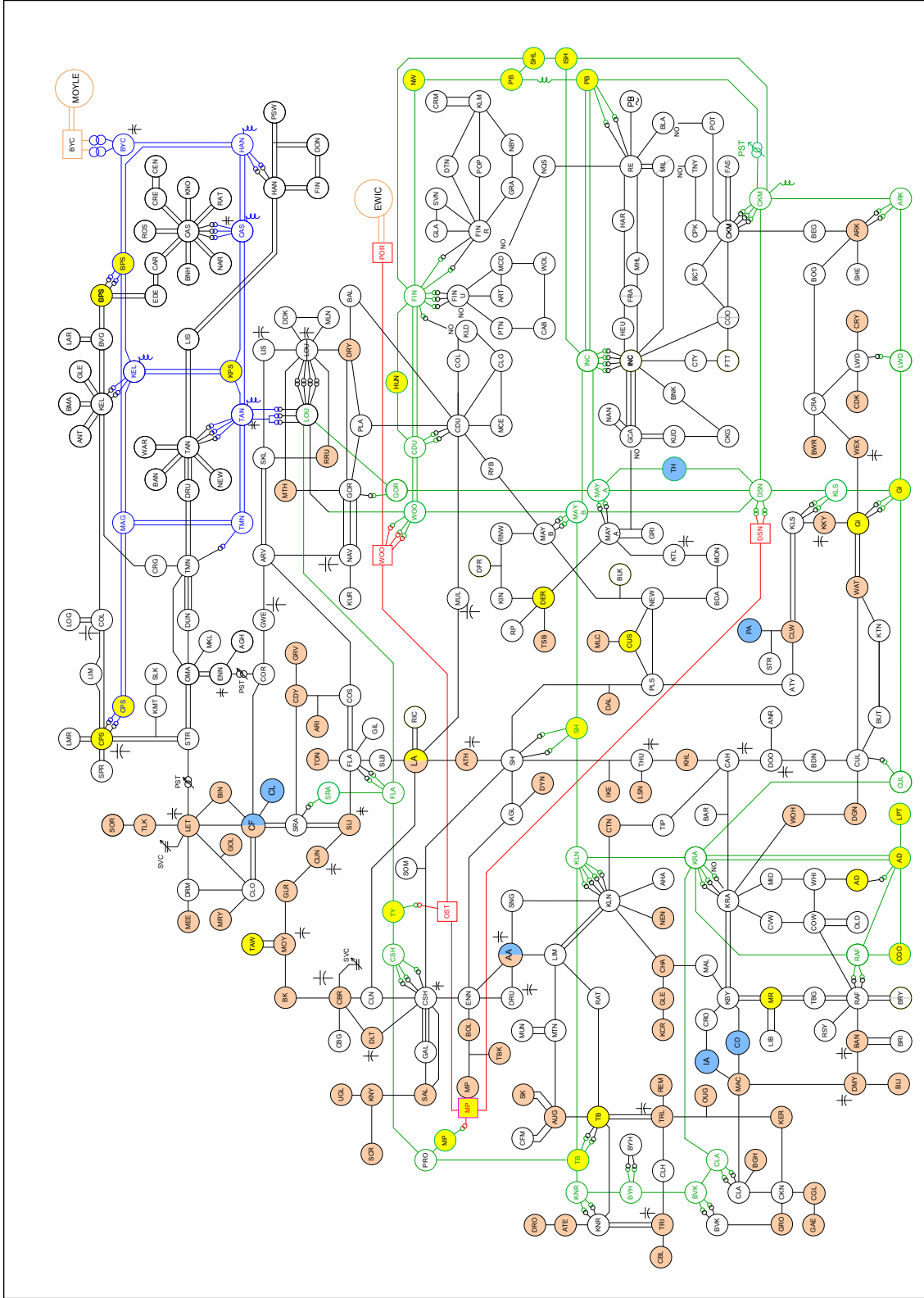

Figure A-3 Schematic Diagram of the All-Island Transmission System as of December 2016

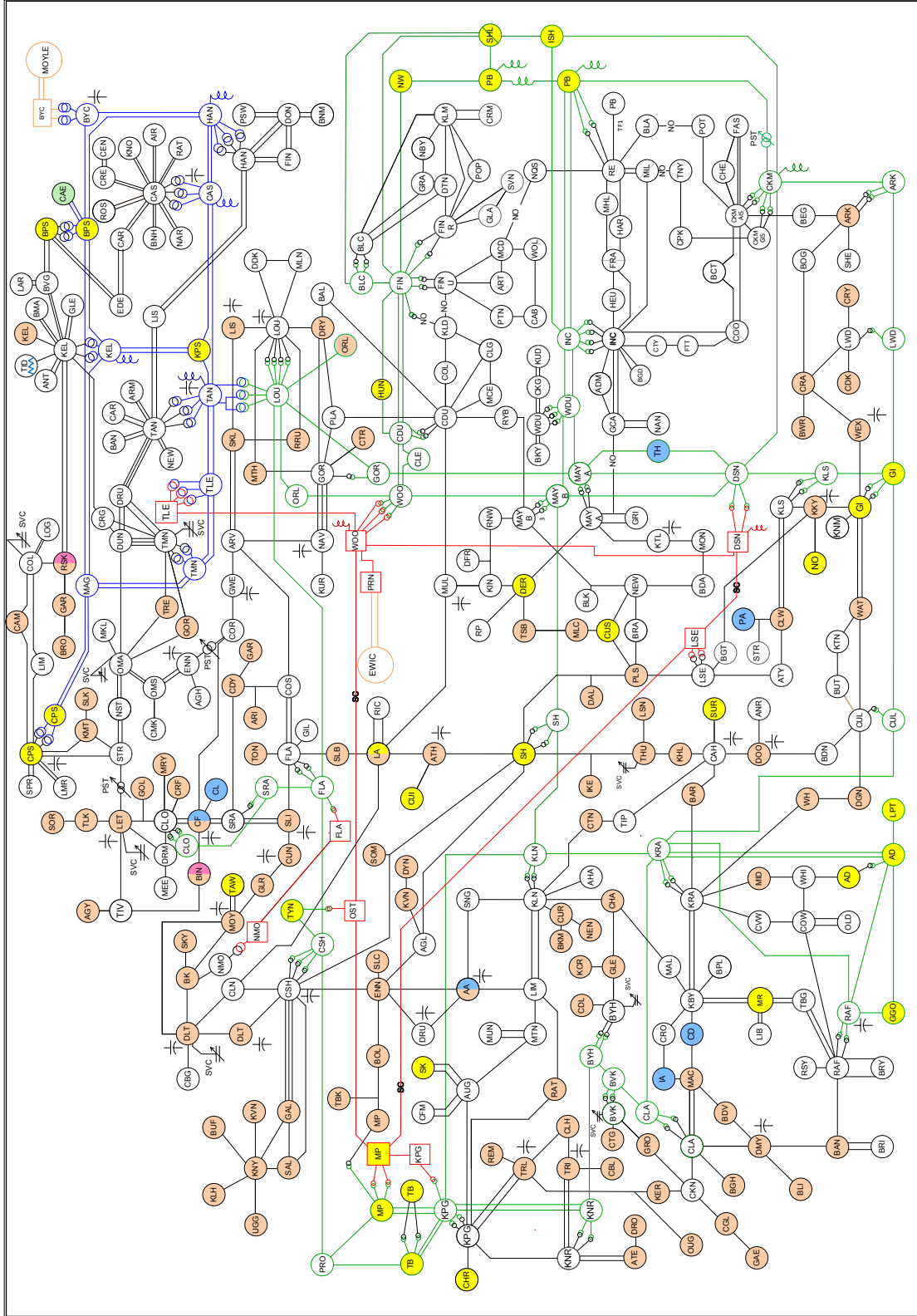
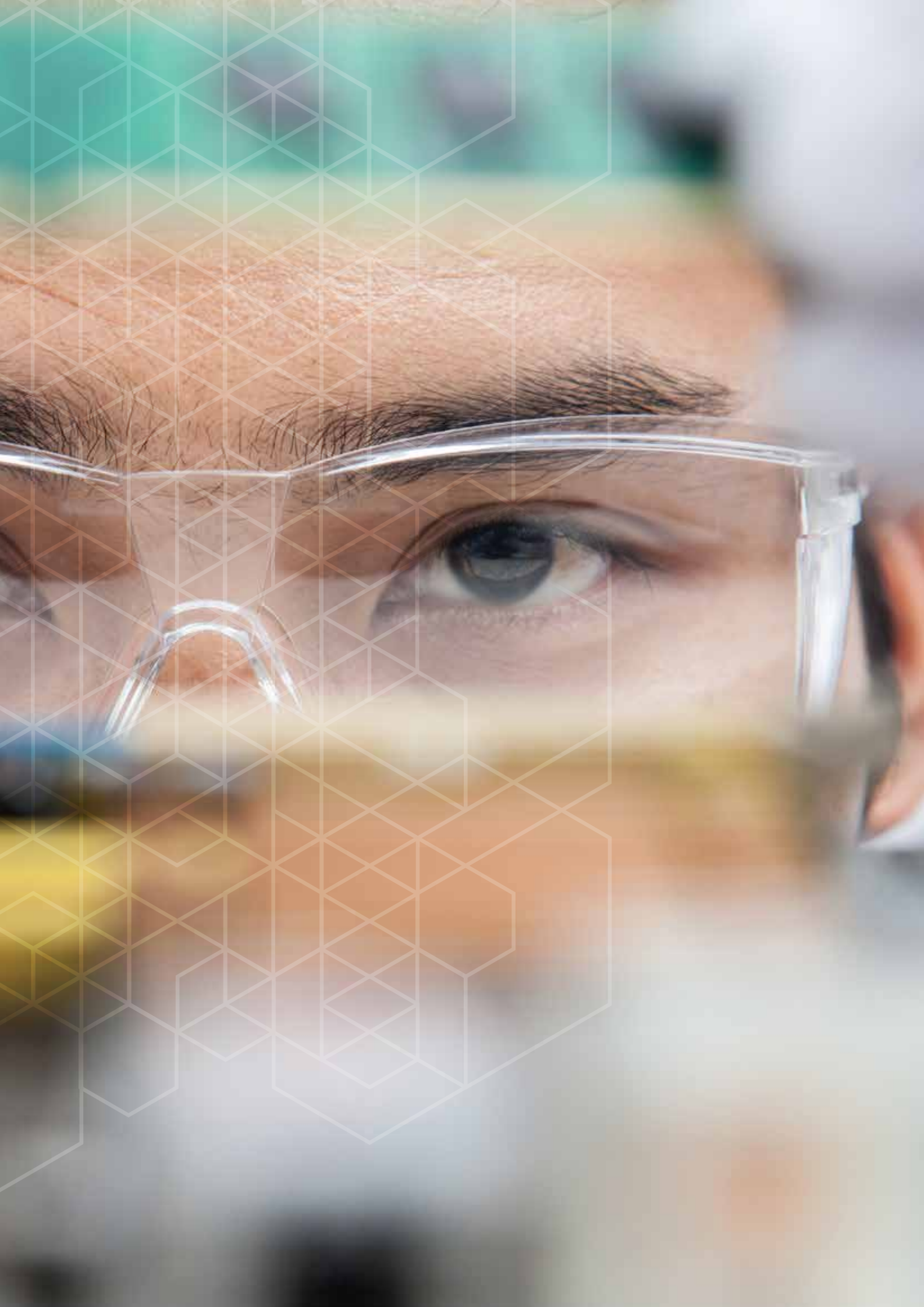

Figure A-4 Schematic Diagram of the All-Island Transmission System as at Year end 2025



All-Island Ten Year

**Transmission Forecast
Statement** **2016**

Appendix B



Appendix B: Transmission System Characteristics

This appendix presents details of the physical and electrical characteristics of the all-island transmission system in tabular form:

- Section B.1 details the data for the existing¹ transmission system; and
- Section B.2 details the data for planned transmission system developments².

Section 1.3 in Chapter 1 of the main text provides information on project developments since the data freeze.

The following is a list of tables in Section B.1:

- Table B-3 Characteristics of Existing Transmission Circuits
- Table B-4 Characteristics of Existing Transformers in Ireland
- Table B-5 Characteristics of Existing Transformers in Northern Ireland
- Table B-6 Characteristics of Existing Power Flow Controllers
- Table B-7 Characteristics of Existing Reactive Compensation

The following is a list of tables in Section B.2:

- Table B-8 Characteristics of future Transmission Circuits
- Table B-9 Characteristics of future Transformers in Ireland
- Table B-10 Characteristics of future Transformers in Northern Ireland
- Table B-11 Characteristics of future Reactive Compensation

Tables B-3 and B-8 include the ratings for lines and cables in MVA for winter and summer reference temperature conditions at 1 per unit (pu) voltage. The higher ambient temperature in summer dictates a reduced thermal rating for overhead lines. The rating is the maximum permissible power that the circuit can transport on a continuous basis. The seasonal reference ambient temperatures are shown in Table B-1:

Table B-1 Reference ambient temperatures

Winter	Summer
5°C	25°C

The electrical characteristics of the all-island transmission system at the four nominal voltage levels are documented. They are represented in per unit values; with a 100 MVA base; and the applicable reference voltage. Table B-2 below displays the four nominal and reference voltage levels on the all-island transmission system.

1. As at summer 2016

2. Includes transmission system reinforcement projects and developments necessary to connect new generation and demand.

Table B-2 Nominal and Reference Voltage Levels

Nominal Voltage Level (kV)	Reference Voltage (kV)
400	400
275	275
220	220
110	110

In some cases equipment associated with a line or cable may be lower rated than the circuit or line. However, this equipment³ is easier to upgrade than lines and cables and is therefore not expected to restrict access to the transmission system.

A small number of 110 kV stations are connected to the transmission system via a tee. A tee is an un-switched connection into an existing line between two other stations. For the purposes of describing the various sections of lines in the following tables, tee points are identified by the name of the tee'd 110 kV station with a suffix "T" added.

B.1 Characteristics of the Existing Transmission System (Summer 2016)

Table B-3 Characteristics of Existing Transmission Circuits

Voltage (kV)	From	To	No.	Length (km)	Impedance on 100 MVA Base (pu)			Rating (MVA)		
					R	X	B	Summer	Autumn	Winter
400	DSN	MP	1	208.5	0.004	0.047	1.049	1577	-	1944
400	MP	OST	1	105.0	0.002	0.023	0.530	1577	-	1944
400	OST	WOO	1	125.0	0.002	0.028	0.631	1577	-	1944
400	WOO	PRT	1	0.5	0.000	0.000	0.043	685	-	685
275	LOU	TAN	1	49.8	0.003	0.021	0.127	710	820	881
275	LOU	TAN	2	49.8	0.003	0.021	0.127	710	820	881
275	BPS	HAN	2	45.5	0.002	0.019	0.114	710	820	881
275	BPS	KEL	1	34.5	0.002	0.014	0.089	710	820	881
275	BPS	MAG	1	65.5	0.003	0.027	0.169	710	820	881
275	BPS	BYC	1	0.8	0.000	0.000	0.002	710	820	881
275	CAC02A	CPS	1	0.2	0.000	0.000	0.040	761	761	837
275	CAC02A	MAG	1	56.0	0.006	0.025	0.151	412	477	513
275	CAC02B	CPS	1	0.2	0.000	0.000	0.034	761	761	837
275	CAC02B	MAG	1	56.0	0.006	0.025	0.151	412	477	513
275	CAS	HAN	1	18.4	0.001	0.008	0.046	710	820	881
275	CAS	HAN	2	18.4	0.001	0.008	0.046	710	820	881

3. Such as Current Transformers, for example.

Table B-3 Characteristics of Existing Transmission Circuits

Voltage (kV)	From	To	No.	Length (km)	Impedance on 100 MVA Base (pu)			Rating (MVA)		
					R	X	B	Summer	Autumn	Winter
275	CAS	KPS	1	66.8	0.003	0.028	0.171	710	820	881
275	CAS	TAN	1	45.6	0.002	0.019	0.114	710	820	881
275	HAN	BYC	1	44.7	0.002	0.019	0.112	710	820	881
275	KEL	KPS	1	29.0	0.001	0.012	0.075	710	820	881
275	KEL	KPS	2	29.0	0.001	0.012	0.075	710	820	881
275	KEL	MAG	1	31.1	0.001	0.013	0.080	710	820	881
275	KPS	TAN	1	80.8	0.004	0.034	0.206	710	820	881
275	MAG	TAN	1	51.6	0.002	0.022	0.129	710	820	881
275	MAG	TMN	1	25.8	0.001	0.011	0.065	710	820	881
275	TAN	TMN	1	25.8	0.001	0.011	0.065	710	820	881
220	AD	AD	1	1.4	0.000	0.001	0.038	593	-	593
220	AD	GGO	1	3.8	0.000	0.002	0.104	593	-	593
220	AD	KRA	1	25.6	0.003	0.022	0.034	434	-	534
220	AD	KRA	2	25.6	0.003	0.022	0.034	434	-	534
220	AD	LPT	1	1.0	0.000	0.000	0.027	593	-	593
220	AD	RAF	1	15.2	0.001	0.009	0.245	434	-	534
220	ARK	CKM	1	53.3	0.006	0.046	0.070	434	-	534
220	ARK	LWD	1	39.0	0.005	0.034	0.051	434	-	534
220	CDU	FIN(I)	1	3.7	0.001	0.003	0.005	434	-	534
220	CDU	FIN(I)	2	3.7	0.001	0.003	0.005	434	-	534
220	CDU	HN	1	4.5	0.000	0.002	0.123	593	-	593
220	CDU	WOO	1	18.4	0.002	0.016	0.024	434	-	534
220	CDU	WOO	2	17.8	0.002	0.016	0.023	434	-	534
220	CKM	DSN	1	41.6	0.005	0.036	0.054	434	-	534
220	CKM	ISH	1	11.5	0.000	0.005	0.315	593	-	593
220	CLA	KNR	1	74.0	0.011	0.055	0.136	761	-	804
220	CLA	KRA	1	45.0	0.006	0.039	0.061	644	-	788
220	CSH	FLA	1	88.1	0.010	0.076	0.115	405	-	405
220	CSH	PRO	1	88.5	0.010	0.077	0.116	392	-	482
220	CSH	TYN	1	33.8	0.005	0.029	0.046	761	-	804

Table B-3 Characteristics of Existing Transmission Circuits

Voltage (kV)	From	To	No.	Length (km)	Impedance on 100 MVA Base (pu)			Rating (MVA)		
					R	X	B	Summer	Autumn	Winter
220	CUL	GI	1	23.3	0.003	0.020	0.045	761	-	804
220	CUL	KRA	1	86.0	0.012	0.074	0.117	761	-	804
220	DSN	KLS	1	59.3	0.007	0.051	0.077	434	-	534
220	DSN	MAY	1	36.3	0.004	0.032	0.048	434	-	534
220	DSN	MAY	2	30.6	0.004	0.027	0.040	434	-	534
220	DSN	TH	1	26.6	0.003	0.022	0.144	351	-	351
220	FIN(I)	HN	1	1.4	0.000	0.001	0.038	593	-	593
220	FIN(I)	NW	1	11.9	0.001	0.004	0.680	332	-	332
220	FIN(I)	SHL	1	13.4	0.001	0.005	0.367	593	-	593
220	FLA	LOU	1	110.1	0.013	0.095	0.144	434	-	534
220	FLA	SRA	1	55.0	0.006	0.048	0.072	434	-	534
220	GGO	RAF	1	9.5	0.000	0.005	0.414	593	-	593
220	GI	KLS	1	69.3	0.008	0.060	0.091	434	-	534
220	GI	LWD	1	47.9	0.006	0.042	0.063	434	-	534
220	GOR (I)	LOU	1	32.4	0.004	0.028	0.042	434	-	534
220	GOR (I)	MAY	1	42.2	0.005	0.037	0.055	434	-	534
220	INC	ISH	1	12.1	0.000	0.005	0.330	593	-	593
220	INC	MAY	2	19.2	0.003	0.017	0.025	548	-	548
220	ISH	SHL	1	1.3	0.000	0.001	0.036	593	-	593
220	KLN	SH	1	89.7	0.014	0.080	0.115	269	-	377
220	KLN	TB	1	70.6	0.008	0.061	0.092	434	-	534
220	KNR	TB	1	22.9	0.003	0.020	0.037	353	-	454
220	KRA	KLN	1	82.4	0.015	0.073	0.107	512	-	565
220	KRA	RAF	1	23.4	0.003	0.020	0.031	353	-	454
220	LOU	WOO	1	61.2	0.007	0.053	0.080	405	-	454
220	MAY	INC	1	19.1	0.003	0.016	0.026	793	-	833
220	MAY	SH	1	105.6	0.017	0.094	0.135	269	-	377
220	MAY	TH	1	53.1	0.006	0.044	0.184	351	-	351
220	MAY	WOO	1	22.3	0.003	0.020	0.030	434	-	534
220	MP	PRO	1	12.7	0.001	0.009	0.021	868	-	1070

Table B-3 Characteristics of Existing Transmission Circuits

Voltage (kV)	From	To	No.	Length (km)	Impedance on 100 MVA Base (pu)			Rating (MVA)		
					R	X	B	Summer	Autumn	Winter
220	NW	PB	1	4.5	0.000	0.001	0.261	332	-	332
220	OST	TYN	1	14.5	0.002	0.013	0.019	434	-	534
220	PB	CKM	1	14.5	0.001	0.005	0.618	267	-	267
220	PB	INC	1	12.5	0.001	0.004	0.504	267	-	267
220	PB	INC	2	11.3	0.001	0.003	0.722	267	-	351
220	PB	PB	1	1.0	0.000	0.037	0.000	450	-	450
220	PB	SHL	1	0.1	0.000	0.000	0.003	593	-	593
220	PRO	TB	1	10.3	0.001	0.007	0.173	467	-	467
110	AA	DRU (I)	1	18.4	0.029	0.067	0.006	99		125
110	AA	ENN (I)	1	32.9	0.051	0.114	0.012	99		124
110	AA	LIM (I)	1	11.7	0.007	0.037	0.012	99		125
110	AD	WHI	1	3.1	0.005	0.011	0.001	99		125
110	ADM	GCA	1	2.5	0.002	0.004	0.025	140		140
110	ADM	INC	1	10.5	0.009	0.027	0.024	103		143
110	AGH	ENN(N)	1	31.1	0.039	0.095	0.019	109	119	124
110	AGL	DYN	1	8.0	0.013	0.028	0.003	105		128
110	AGL	ENN (I)	1	38.2	0.059	0.131	0.012	99		128
110	AGL	SH	1	46.2	0.072	0.159	0.015	105		128
110	AHA	KLN	1	3.8	0.004	0.012	0.004	112		112
110	ANR	DOO	1	2.0	0.003	0.007	0.001	105		128
110	ANT	KEL	1	8.9	0.012	0.030	0.003	82	95	103
110	ANT	KEL	2	8.9	0.012	0.030	0.003	82	95	103
110	ARI	ARI T	1	0.2	0.000	0.001	0.000	105		128
110	ARK	BEG	1	21.9	0.010	0.079	0.007	136		166
110	ARK	BOG	1	29.0	0.021	0.095	0.010	178		219
110	ARK	SHE	2	2.2	0.004	0.008	0.001	34		57
110	ART	FIN (I)	1	9.0	0.005	0.010	0.055	120		131
110	ART	MCD	1	4.9	0.003	0.006	0.030	120		131
110	ARV	COS	1	43.0	0.067	0.148	0.014	99		125
110	ARV	GWE	1	30.6	0.019	0.099	0.011	178		219

Table B-3 Characteristics of Existing Transmission Circuits

Voltage (kV)	From	To	No.	Length (km)	Impedance on 100 MVA Base (pu)			Rating (MVA)		
					R	X	B	Summer	Autumn	Winter
110	ARV	NAV	1	65.5	0.041	0.213	0.023	178		219
110	ARV	SKL	1	18.6	0.029	0.065	0.006	80		110
110	ARV	SKL	2	23.6	0.015	0.076	0.010	80		219
110	ATE	DRO	1	5.5	0.003	0.003	0.064	140		140
110	ATE	KNR	1	9.0	0.006	0.029	0.003	178		219
110	ATH	CUI	1	2.3	0.002	0.003	0.023	140		140
110	ATH	LA	1	35.8	0.054	0.123	0.012	105		128
110	ATH	SH	1	21.6	0.014	0.070	0.011	178		219
110	ATY	CLW	1	25.0	0.039	0.086	0.008	99		125
110	ATY	PLS	1	26.6	0.041	0.092	0.009	99		125
110	AUG	CFM	1	0.7	0.001	0.002	0.001	96		96
110	AUG	CFM	2	0.7	0.001	0.002	0.001	96		96
110	AUG	MTN	1	27.5	0.017	0.089	0.010	178		219
110	AUG	SK	3	1.0	0.001	0.001	0.006	120		131
110	AUG	SK	4	1.0	0.001	0.001	0.006	120		131
110	AUG	TB	1	34.0	0.021	0.111	0.012	152		152
110	BAL	CDU	1	16.8	0.011	0.055	0.006	178		219
110	BAL	DRY	1	20.0	0.013	0.065	0.007	178		219
110	BAN (I)	BRI	1	2.6	0.004	0.009	0.001	105		128
110	BAN (I)	BRI	2	2.5	0.004	0.009	0.001	105		128
110	BAN (I)	DMY	1	25.9	0.040	0.089	0.008	99		125
110	BAN (I)	RAF	1	26.9	0.041	0.091	0.012	105		128
110	BAN (N)	TAN	1	18.4	0.024	0.062	0.006	82	95	103
110	BAN (N)	TAN	2	14.2	0.019	0.049	0.005	82	95	103
110	BAR	BART	1	0.3	0.000	0.001	0.000	136		166
110	BCT	CKM	1	3.1	0.002	0.005	0.031	140		140
110	BDA	MON	1	12.5	0.012	0.037	0.031	99		124
110	BDA	NEW (I)	1	7.9	0.007	0.021	0.030	120		124
110	BDN	CUL	1	21.8	0.031	0.075	0.007	196		222
110	BDN	DOO	1	11.3	0.000	0.037	0.004	178		219

Table B-3 Characteristics of Existing Transmission Circuits

Voltage (kV)	From	To	No.	Length (km)	Impedance on 100 MVA Base (pu)			Rating (MVA)		
					R	X	B	Summer	Autumn	Winter
110	BEG	CKM	1	32.3	0.015	0.116	0.010	136		166
110	BGH	CLA	1	13.5	0.008	0.040	0.039	178		219
110	BIN	CF	1	34.3	0.053	0.118	0.011	105		128
110	BIN	LET	1	69.0	0.072	0.230	0.024	136		166
110	BK	CBR	1	37.4	0.058	0.128	0.013	99		125
110	BK	MOY	1	27.0	0.042	0.093	0.009	99		114
110	BLA	POT	1	5.2	0.002	0.004	0.092	119		119
110	BLA	RE	1	7.7	0.003	0.006	0.136	119		119
110	BLI	DMY	1	27.6	0.043	0.094	0.010	105		128
110	BLK	BLK T	1	0.5	0.001	0.002	0.000	136		166
110	BMA	KEL	1	10.0	0.013	0.035	0.003	109	119	124
110	BMA	KEL	2	11.5	0.015	0.040	0.004	109	119	124
110	BNH	CAS	1	21.2	0.028	0.071	0.007	82	95	103
110	BNH	CAS	2	21.2	0.028	0.071	0.007	82	95	103
110	BOG	CRA	1	24.7	0.018	0.081	0.009	178		219
110	BOL	ENN (I)	1	24.0	0.037	0.083	0.008	105		128
110	BOL	TBK T	1	19.6	0.031	0.067	0.006	105		128
110	BPS	BVG	1	17.3	0.023	0.058	0.006	82	95	103
110	BPS	BVG	2	17.3	0.023	0.058	0.006	82	95	103
110	BPS	EDE	1	15.1	0.023	0.054	0.005	69	80	86
110	BPS	EDE	2	15.1	0.023	0.053	0.005	70	81	87
110	BRY	RAF	1	1.7	0.003	0.006	0.001	63		99
110	BRY	RAF	2	1.8	0.002	0.006	0.001	105		128
110	BUT	CUL	1	12.3	0.080	0.040	0.013	178		219
110	BUT	KTN	1	2.7	0.004	0.010	0.001	200		221
110	BVG	KEL	1	21.2	0.028	0.073	0.007	109	119	124
110	BVG	KEL	2	20.3	0.027	0.070	0.007	109	119	124
110	BVG	LAR	1	7.1	0.007	0.023	0.002	79	96	113
110	BVG	LAR	2	7.1	0.007	0.023	0.002	79	96	113
110	BWR	CRA	1	21.9	0.011	0.030	0.137	116		116

Table B-3 Characteristics of Existing Transmission Circuits

Voltage (kV)	From	To	No.	Length (km)	Impedance on 100 MVA Base (pu)			Rating (MVA)		
					R	X	B	Summer	Autumn	Winter
110	CAB	PTN	1	2.7	0.002	0.007	0.005	80		129
110	CAB	WOL	1	4.7	0.003	0.005	0.029	120		131
110	CAH	BART	1	43.7	0.065	0.150	0.014	105		128
110	CAH	DOO	1	15.7	0.010	0.051	0.006	178		219
110	CAH	KHL	1	21.8	0.013	0.066	0.033	178		219
110	CAH	TIP	1	18.1	0.011	0.059	0.006	105	178	219
110	CAR	CAS	1	24.7	0.037	0.088	0.008	69	80	86
110	CAR	CAS	2	24.7	0.037	0.086	0.008	70	81	87
110	CAR	EDE	1	12.4	0.019	0.043	0.004	70	81	87
110	CAR	EDE	2	12.4	0.019	0.044	0.004	69	80	86
110	CAS	CRE	1	3.0	0.001	0.004	0.061	132	132	145
110	CAS	CRE	2	3.0	0.001	0.004	0.061	132	132	145
110	CAS	KNO	1	4.5	0.005	0.004	0.044	66	66	73
110	CAS	KNO	2	4.5	0.005	0.004	0.044	66	66	73
110	CAS	NAR	1	18.0	0.015	0.040	0.071	109	119	124
110	CAS	NAR	2	19.8	0.018	0.046	0.070	109	119	124
110	CAS	RAT (N)	1	18.9	0.025	0.064	0.006	82	95	103
110	CAS	RAT (N)	2	18.9	0.025	0.064	0.006	82	95	103
110	CAS	ROS	1	1.9	0.001	0.002	0.026	117	117	128
110	CAS	ROS	2	1.9	0.001	0.002	0.026	117	117	128
110	CBL	TRI	1	13.8	0.009	0.029	0.090	124		124
110	CBR	CBG	1	26.5	0.038	0.083	0.052	99		124
110	CBR	CLN	1	57.5	0.089	0.198	0.020	99		125
110	CBR	DLT	1	27.8	0.043	0.096	0.009	90		95
110	CD	KBY	1	32.1	0.020	0.104	0.011	178		219
110	CD	MAC	1	2.4	0.004	0.008	0.001	99	178	219
110	CDK	LWD	1	6.6	0.003	0.009	0.041	116		116
110	CDU	MUL	1	73.3	0.088	0.237	0.041	105		128
110	CDU	PLA	1	37.0	0.023	0.120	0.013	178		219
110	CDU	RYB	1	13.0	0.014	0.043	0.005	178	178	219

Table B-3 Characteristics of Existing Transmission Circuits

Voltage (kV)	From	To	No.	Length (km)	Impedance on 100 MVA Base (pu)			Rating (MVA)		
					R	X	B	Summer	Autumn	Winter
110	CDY	ARIT	1	13.7	0.014	0.046	0.005	136		166
110	CDY	GRV	1	7.3	0.005	0.024	0.003	178		219
110	CDY	SRA	1	12.7	0.020	0.044	0.004	99		125
110	CEN	CRE	1	4.2	0.001	0.004	0.030	144	144	144
110	CEN	CRE	2	4.2	0.001	0.004	0.030	144	144	144
110	CF	CL	1	5.5	0.006	0.018	0.002	178		219
110	CF	COR	1	61.3	0.039	0.199	0.022	178		219
110	CF	DRM	1	51.3	0.077	0.176	0.017	99		125
110	CF	GOLT	1	25.5	0.036	0.093	0.009	196		222
110	CF	SRA	1	53.0	0.065	0.179	0.021	187		190
110	CGL	BVK	1	30.0	0.019	0.098	0.011	178		219
110	CGL	CKN	1	6.3	0.004	0.021	0.002	178		219
110	CGL	GAE	1	2.0	0.001	0.003	0.015	130		130
110	CHA	GLE (I)	1	30.0	0.047	0.103	0.010	105		128
110	CHA	KLN	1	36.9	0.039	0.123	0.013	136		166
110	CHA	MAL	1	22.5	0.014	0.073	0.008	178		219
110	CHE	FAS	1	2.2	0.004	0.008	0.001	105		128
110	CKG	BKY	1	3.0	0.001	0.003	0.033	187		223
110	CKG	KUD	1	0.8	0.000	0.001	0.008	187		223
110	CKM	CHE	1	4.0	0.004	0.008	0.030	105		128
110	CKM	CPK	1	0.1	0.000	0.000	0.000	136		166
110	CKM	FAS	1	2.9	0.005	0.010	0.001	105		128
110	CKM	POT	1	3.2	0.001	0.003	0.057	119		119
110	CKN	KER	1	20.3	0.013	0.066	0.007	178		219
110	CLA	CKN	1	29.8	0.019	0.097	0.011	178		219
110	CLA	MAC	1	5.7	0.004	0.018	0.002	160		196
110	CLG	KDN	1	3.6	0.004	0.011	0.007	124		124
110	CLG	MCE	1	4.7	0.005	0.015	0.005	99		125
110	CLH	TRI	1	9.0	0.014	0.031	0.003	99		125
110	CLH	TRL	1	13.5	0.020	0.045	0.025	105		128

Table B-3 Characteristics of Existing Transmission Circuits

Voltage (kV)	From	To	No.	Length (km)	Impedance on 100 MVA Base (pu)			Rating (MVA)		
					R	X	B	Summer	Autumn	Winter
110	CLN	LA	1	64.8	0.095	0.222	0.021	99		125
110	CLW	KLS	1	5.4	0.008	0.019	0.002	99		125
110	CLW	KLS	2	5.3	0.008	0.019	0.002	99		125
110	CLW	STR (I)	1	17.6	0.027	0.061	0.006	105		128
110	COL (I)	CDU	1	2.7	0.001	0.004	0.020	130		130
110	COL (I)	KDN	1	5.0	0.003	0.013	0.037	104		124
110	COL (N)	CPS	1	46.7	0.061	0.161	0.015	82	95	103
110	COL (N)	KEL	1	58.9	0.067	0.201	0.020	109	119	124
110	COL (N)	LIM (N)	1	18.6	0.024	0.064	0.006	82	95	103
110	COL (N)	LOG	1	8.1	0.011	0.027	0.003	82	95	103
110	COL (N)	LOG	2	8.1	0.011	0.027	0.003	82	95	103
110	COO	BCT	1	15.1	0.014	0.045	0.027	130		130
110	COO	CKM	2	16.0	0.013	0.042	0.060	130		130
110	COR	ENN(I)	1	27.5	0.043	0.095	0.009	105		128
110	COR	GWE	1	10.9	0.007	0.036	0.004	161		196
110	COS	ARIT	1	20.7	0.022	0.069	0.007	120		128
110	COS	FLA	1	3.4	0.005	0.012	0.001	99		125
110	COS	FLA	2	3.4	0.005	0.011	0.001	99		125
110	COW	CVW	1	17.2	0.025	0.054	0.018	99		125
110	COW	OLD	1	2.3	0.004	0.008	0.001	105		128
110	COW	OLD	2	2.2	0.003	0.008	0.001	105		128
110	COW	RAF	1	6.9	0.010	0.024	0.003	99		125
110	COW	WHI	1	17.8	0.027	0.062	0.006	105		128
110	CPK	CPK T	1	3.4	0.002	0.004	0.025	100		100
110	CPK	TLY	1	5.6	0.003	0.006	0.073	100		100
110	CPS	KMT	1	14.5	0.011	0.048	0.005	143	158	166
110	CPS	LIM (N)	1	29.5	0.039	0.101	0.010	82	95	103
110	CPS	LMR	1	9.0	0.012	0.030	0.003	82	95	103
110	CPS	LMR	1	9.0	0.012	0.030	0.003	82	95	103
110	CPS	SPR	1	9.2	0.011	0.029	0.012	82	95	103

Table B-3 Characteristics of Existing Transmission Circuits

Voltage (kV)	From	To	No.	Length (km)	Impedance on 100 MVA Base (pu)			Rating (MVA)		
					R	X	B	Summer	Autumn	Winter
110	CPS	SPR	2	9.4	0.011	0.029	0.013	82	95	103
110	CPS	STR (N)	1	27.0	0.018	0.053	0.017	143	158	166
110	CRA	LWD	1	8.0	0.005	0.026	0.003	178		219
110	CRA	WEX	1	21.3	0.022	0.071	0.007	136		166
110	CRG	DUN	1	37.4	0.047	0.125	0.017	82	95	103
110	CRG	KEL	1	23.1	0.029	0.077	0.013	82	95	103
110	CRM	KLM	1	1.4	0.001	0.002	0.014	140		140
110	CRM	KLM	2	1.4	0.001	0.002	0.014	140		140
110	CRO	IA	1	2.7	0.004	0.001	0.001	196		222
110	CRO	KBY	1	14.4	0.009	0.047	0.005	178		219
110	CSH	CLN	1	22.8	0.014	0.074	0.008	178		219
110	CSH	DLT	1	60.8	0.075	0.205	0.020	99		125
110	CSH	ENN (I)	1	53.5	0.034	0.174	0.019	178		219
110	CSH	GAL	1	13.8	0.022	0.048	0.005	99		125
110	CSH	GAL	2	11.3	0.018	0.039	0.004	99		125
110	CSH	GAL	3	11.3	0.018	0.039	0.004	99		125
110	CSH	SAL	1	24.9	0.025	0.072	0.068	99		105
110	CSH	SOM T	1	50.0	0.078	0.172	0.016	99		125
110	CTN	KLN	1	28.1	0.044	0.098	0.009	105		128
110	CTN	TIP	1	13.2	0.008	0.043	0.005	105		129
110	CTY	COO	1	2.9	0.004	0.010	0.001	103		128
110	CTY	INC	1	8.9	0.011	0.030	0.003	103		128
110	CUL	DGN	1	34.2	0.022	0.109	0.020	178		219
110	CUL	WAT	1	13.1	0.006	0.033	0.055	178		219
110	CUN	GLR	1	25.9	0.037	0.095	0.009	178		219
110	CUN	SLI	1	21.3	0.033	0.073	0.007	99		126
110	CUS	MLC	1	13.7	0.015	0.048	0.005	136		166
110	CUS	NEW (I)	1	24.6	0.026	0.082	0.008	136		166
110	CUS	PLS	1	42.1	0.044	0.140	0.014	136		166
110	CVW	DKL	1	0.4	0.001	0.001	0.000	105		128

Table B-3 Characteristics of Existing Transmission Circuits

Voltage (kV)	From	To	No.	Length (km)	Impedance on 100 MVA Base (pu)			Rating (MVA)		
					R	X	B	Summer	Autumn	Winter
110	CVW	KRA	1	7.6	0.012	0.026	0.004	99		125
110	DAL	DAL T	1	12.2	0.019	0.042	0.004	105		128
110	DAL T	KPN	1	25.5	0.016	0.083	0.009	178		219
110	DDK	LOU	1	16.8	0.026	0.058	0.005	105		128
110	DDK	MLN	1	7.5	0.012	0.026	0.003	105		128
110	DER	KIN	1	15.1	0.012	0.050	0.005	99		125
110	DER	MAY	1	43.0	0.027	0.139	0.018	74		93
110	DER	TSB	1	19.7	0.031	0.068	0.006	105		128
110	DFR	DFR T	1	0.1	0.000	0.000	0.000	105		128
110	DGN	WH	1	8.7	0.006	0.028	0.003	178		219
110	DMY	MAC	1	26.2	0.037	0.096	0.009	120		222
110	DON	BNM	1	6.3	0.006	0.006	0.066	75	75	82
110	DON	BNM	2	6.3	0.006	0.006	0.066	75	75	82
110	DON	FIN (N)	1	3.7	0.004	0.011	0.008	69	80	86
110	DON	FIN (N)	2	3.7	0.004	0.011	0.007	69	80	86
110	DON	HAN	1	5.8	0.002	0.005	0.140	144	144	158
110	DON	HAN	2	5.8	0.002	0.005	0.140	144	144	158
110	DRM	LET	1	8.3	0.013	0.028	0.003	105		128
110	DRM	MEE	1	5.0	0.008	0.017	0.002	105		128
110	DRU (I)	ENN (I)	1	17.4	0.027	0.060	0.006	99		125
110	DRU (N)	DUN	1	25.5	0.033	0.087	0.009	82	95	103
110	DRU (N)	DUN	2	28.7	0.037	0.095	0.010	82	95	103
110	DRU (N)	TAN	1	4.4	0.004	0.014	0.002	79	96	113
110	DRU (N)	TAN	2	4.4	0.004	0.014	0.002	79	96	113
110	DRU (N)	TAN	3	4.1	0.005	0.014	0.001	79	96	113
110	DRY	GOR (I)	1	19.4	0.029	0.067	0.006	99		125
110	DRY	LOU	1	31.9	0.020	0.104	0.011	178		219
110	DRY	PLA	1	5.3	0.008	0.018	0.002	105		128
110	DTN	FIN (I)	1	9.2	0.002	0.014	0.111	140		140
110	DTN	KLM	1	3.2	0.002	0.005	0.032	140		140

Table B-3 Characteristics of Existing Transmission Circuits

Voltage (kV)	From	To	No.	Length (km)	Impedance on 100 MVA Base (pu)			Rating (MVA)		
					R	X	B	Summer	Autumn	Winter
110	DUN	OMA	1	36.1	0.042	0.124	0.012	150	150	150
110	DUN	OMA	2	39.5	0.047	0.135	0.013	150	150	150
110	DUN	TMN	1	5.9	0.004	0.017	0.005	132		152
110	ENN (N)	OMA	1	33.8	0.044	0.113	0.011	82	95	103
110	ENN (N)	OMA	2	33.7	0.044	0.113	0.011	82	95	103
110	FAS	CKM	1	7.5	0.012	0.026	0.002	105		128
110	FAS E	FAS	1	5.0	0.008	0.017	0.002	105		128
110	FIN (I)	GLA	1	14.0	0.022	0.048	0.005	105		128
110	FIN (I)	GRA	1	13.2	0.005	0.012	0.236	119		119
110	FIN (I)	MCD	1	7.9	0.003	0.007	0.141	119		119
110	FIN (I)	POP	1	4.3	0.002	0.005	0.026	120		131
110	FIN (I)	PTN	1	3.5	0.003	0.010	0.006	80		129
110	FIN (I)	SVN	1	32.2	0.039	0.104	0.056	105		115
110	FIN (N)	HAN	1	3.1	0.001	0.003	0.022	144	144	144
110	FIN (N)	HAN	2	3.1	0.001	0.003	0.022	144	144	144
110	FLA	GIL	1	10.6	0.017	0.037	0.003	105		128
110	FLA	LA	1	30.6	0.048	0.105	0.010	99		125
110	FLA	SLI	1	50.5	0.079	0.174	0.016	105		128
110	FLA	TON	1	32.3	0.050	0.111	0.010	99		126
110	FRN	HAR	1	2.3	0.002	0.004	0.030	107		107
110	FRN	HEU	1	2.4	0.002	0.004	0.024	140		140
110	FRN	INC	1	5.6	0.004	0.010	0.073	107		107
110	FRN	MHL	1	4.2	0.003	0.006	0.042	140		140
110	GAL	SAL	1	6.1	0.004	0.009	0.061	105		105
110	GCA	GRI	1	8.9	0.009	0.029	0.006	103		131
110	GCA	GRI T	1	8.9	0.009	0.029	0.006	103		131
110	GCA	INC	1	8.1	0.008	0.025	0.009	103		143
110	GCA	INC	2	8.1	0.008	0.025	0.009	103		143
110	GCA	INC	3	7.7	0.005	0.004	0.004	103		124
110	GCA	KUD	1	2.1	0.002	0.003	0.021	140		140

Table B-3 Characteristics of Existing Transmission Circuits

Voltage (kV)	From	To	No.	Length (km)	Impedance on 100 MVA Base (pu)			Rating (MVA)		
					R	X	B	Summer	Autumn	Winter
110	GCA	KUD	2	2.1	0.002	0.003	0.021	140		140
110	GCA	NAN	1	1.8	0.001	0.002	0.011	120		131
110	GCA	NAN	2	1.7	0.001	0.002	0.011	120		131
110	GI	KKY	1	49.2	0.077	0.169	0.016	99		125
110	GI	WAT	1	11.7	0.007	0.038	0.004	178		219
110	GI	WAT	2	12.9	0.008	0.042	0.005	178		219
110	GI	WEX	1	34.5	0.054	0.119	0.011	99		125
110	GLA	SVN	1	18.0	0.017	0.055	0.052	136		154
110	GLE (N)	KEL	1	21.4	0.027	0.068	0.027	82	82	90
110	GLE (N)	KEL	1	21.4	0.027	0.068	0.027	82	82	90
110	GOL	GOL T	1	3.9	0.006	0.014	0.001	105		128
110	GOR (I)	MTH	1	27.3	0.028	0.090	0.013	99		125
110	GOR (I)	NAV	1	5.3	0.008	0.019	0.002	99		125
110	GOR (I)	NAV	2	6.3	0.009	0.022	0.002	99		125
110	GOR (I)	NAV	3	6.5	0.007	0.022	0.002	99		125
110	GOR (I)	PLA	1	19.7	0.030	0.068	0.006	103		143
110	GRA	NBY	1	5.1	0.002	0.005	0.089	119		119
110	GRI	GRI T	1	1.0	0.002	0.004	0.000	105		128
110	GRO	CKN	1	15.2	0.008	0.014	0.150	120		120
110	HAN	LIS (N)	1	9.2	0.010	0.026	0.018	82	95	103
110	HAN	LIS (N)	2	9.2	0.009	0.026	0.018	80	93	100
110	HAR	RE	1	5.6	0.005	0.010	0.073	107		107
110	HEU	INC	1	3.6	0.003	0.005	0.036	140		140
110	IA	MAC	1	18.6	0.027	0.068	0.006	211		222
110	IKE	IKE T	1	0.2	0.000	0.001	0.000	80		129
110	INC	BKY	1	10.0	0.002	0.011	0.110	187		
110	INC	COO	1	6.2	0.006	0.016	0.029	136		140
110	INC	MIL	1	8.4	0.004	0.009	0.051	120		131
110	KCR	GLE (I)	1	11.2	0.008	0.017	0.115	140		140
110	KER	OUG T	1	22.6	0.014	0.074	0.008	178		219

Table B-3 Characteristics of Existing Transmission Circuits

Voltage (kV)	From	To	No.	Length (km)	Impedance on 100 MVA Base (pu)			Rating (MVA)		
					R	X	B	Summer	Autumn	Winter
110	KHL	THU	1	21.8	0.013	0.066	0.033	178		219
110	KIN	DFR T	1	29.3	0.021	0.096	0.010	99		125
110	KKY	KLS	1	34.3	0.053	0.118	0.011	99		125
110	KLM	NBY	1	1.2	0.001	0.001	0.020	119		119
110	KLM	POP	1	6.0	0.003	0.007	0.037	120		131
110	KLN	LIM (I)	1	9.0	0.014	0.031	0.003	99		125
110	KLN	NEN	1	33.6	0.052	0.116	0.018	105		128
110	KLN	SNG	1	4.1	0.003	0.013	0.003	178		219
110	KMT	SLK	1	6.2	0.007	0.018	0.006	98	105	110
110	KMT	STR (N)	1	11.2	0.008	0.037	0.004	143	158	166
110	KNR	TB	1	15.0	0.016	0.050	0.005	136		166
110	KNR	TRI	1	4.4	0.005	0.017	0.002	120		128
110	KNR	TRI	2	5.7	0.004	0.019	0.002	178		219
110	KRA	BAR	1	19.5	0.020	0.065	0.007	136		166
110	KRA	KBY	1	11.9	0.008	0.039	0.004	178		219
110	KRA	KBY	2	12.5	0.018	0.043	0.004	99		125
110	KRA	MID	1	10.7	0.017	0.037	0.004	99		125
110	KRA	WH	1	45.4	0.029	0.147	0.016	178		219
110	KTL	MAY	1	21.4	0.022	0.072	0.007	99		125
110	KTL	MON	1	8.9	0.009	0.030	0.003	136		166
110	KTN	WAT	1	5.0	0.004	0.008	0.050	99		125
110	KUR	NAV	1	6.1	0.010	0.021	0.002	105		128
110	LA	MUL	1	46.3	0.072	0.160	0.015	105		128
110	LA	RIC	1	15.7	0.024	0.054	0.007	105		128
110	LA	RIC	2	12.5	0.020	0.043	0.005	105		128
110	LA	SLB	1	9.1	0.014	0.031	0.003	105		128
110	LET	GOL T	1	38.4	0.058	0.132	0.012	103		128
110	LET	STR (N)	1	22.3	0.035	0.077	0.007	105		128
110	LET	TLK	1	34.9	0.054	0.120	0.013	105		128
110	LIB	MR	1	2.7	0.001	0.003	0.017	100		100

Table B-3 Characteristics of Existing Transmission Circuits

Voltage (kV)	From	To	No.	Length (km)	Impedance on 100 MVA Base (pu)			Rating (MVA)		
					R	X	B	Summer	Autumn	Winter
110	LIB	MR	2	2.7	0.002	0.003	0.017	120		131
110	LIM (I)	KLN	1	11.7	0.018	0.040	0.009	80		110
110	LIM (I)	MTN	1	6.5	0.005	0.025	0.003	178		219
110	LIM (I)	RAT (I)	1	29.1	0.044	0.101	0.012	99		125
110	LIS (I)	LOU	1	40.4	0.063	0.139	0.013	105		128
110	LIS (I)	SKL	1	39.3	0.061	0.135	0.013	105		128
110	LIS (N)	TAN	1	31.0	0.040	0.106	0.010	82	95	103
110	LIS (N)	TAN	2	29.2	0.034	0.100	0.009	80	93	100
110	LOU	MLN	1	13.0	0.020	0.045	0.004	105		128
110	LOU	RRU	1	37.5	0.058	0.129	0.012	105		128
110	LSN	THU	1	10.4	0.016	0.036	0.003	99		125
110	MAL	KBY	1	29.2	0.018	0.095	0.010	136		166
110	MAY	BLK T	1	30.9	0.032	0.103	0.011	136		166
110	MAY	GRI	1	2.2	0.003	0.009	0.001	105		128
110	MAY	GRI T	1	2.2	0.002	0.007	0.002	103		120
110	MAY	RNW	1	7.1	0.008	0.024	0.002	103		128
110	MAY	RYB	1	9.0	0.009	0.030	0.005	178		219
110	MCD	NQS	1	2.0	0.001	0.002	0.036	119		119
110	MCD	WOL	1	1.4	0.001	0.002	0.009	120		131
110	MCE	CDU	1	4.1	0.003	0.010	0.016	99		125
110	MHL	RE	1	3.0	0.002	0.005	0.030	140		140
110	MID	WHI	1	20.0	0.030	0.069	0.007	99		125
110	MIL	RE	1	4.9	0.003	0.005	0.075	100		100
110	MIL	RE	2	5.6	0.003	0.006	0.034	100		131
110	MIL	TLY	1	5.5	0.003	0.006	0.070	100		100
110	MKL	OMA	1	37.5	0.028	0.113	0.015	139	150	157
110	MOY	GLR	1	14.0	0.022	0.048	0.005	99		125
110	MOY	TAW	1	8.4	0.013	0.029	0.003	105		125
110	MOY	TAW	2	8.3	0.013	0.029	0.003	105		128
110	MP	TBK T	1	6.6	0.010	0.023	0.002	105		128

Table B-3 Characteristics of Existing Transmission Circuits

Voltage (kV)	From	To	No.	Length (km)	Impedance on 100 MVA Base (pu)			Rating (MVA)		
					R	X	B	Summer	Autumn	Winter
110	MR	KBY	1	4.0	0.004	0.013	0.003	99		115
110	MR	KBY	2	4.0	0.004	0.013	0.003	99		115
110	MR	TBG	1	3.3	0.001	0.004	0.036	178		219
110	MR	TBG	2	3.3	0.001	0.004	0.036	178		219
110	MTH	LOU	1	15.1	0.024	0.052	0.005	99		125
110	MTN	MUN	1	0.7	0.001	0.003	0.000	105		128
110	MTN	MUN	2	0.7	0.001	0.002	0.000	105		128
110	NEW (I)	BLK T	1	12.2	0.013	0.041	0.004	136		166
110	NEW (I)	PLS	1	43.0	0.055	0.146	0.014	105		128
110	NEW (N)	TAN	1	24.1	0.031	0.080	0.008	82	95	103
110	NEW (N)	TAN	2	24.0	0.031	0.080	0.008	82	95	103
110	NQS	RE	1	2.1	0.001	0.002	0.038	119		119
110	OMA	STR (N)	1	35.5	0.046	0.123	0.012	109	119	124
110	OMA	STR (N)	2	36.1	0.047	0.125	0.012	109		103
110	OUG	OUG T	1	11.0	0.017	0.038	0.004	105		128
110	PA	STR (I)	1	22.4	0.035	0.077	0.007	105		128
110	PB	RE	3	1.4	0.000	0.002	0.046	269		269
110	PB	RE	4	1.4	0.000	0.002	0.046	269		269
110	PLS	DAL T	1	32.0	0.020	0.104	0.011	178		219
110	RAF	RSY	1	2.1	0.003	0.007	0.001	63		99
110	RAF	TBG	1	10.6	0.016	0.036	0.005	105		128
110	RAF	TBG	2	9.5	0.006	0.031	0.005	178		219
110	RAT (I)	TB	1	33.6	0.035	0.112	0.012	136		166
110	RE	PB	1	1.2	0.001	0.001	0.016	112		112
110	REM	TRL	1	12.0	0.006	0.018	0.120	106		106
110	RNW	DFR T	1	25.9	0.020	0.085	0.009	99		125
110	RRU	SKL	1	14.5	0.023	0.050	0.005	99		125
110	SCR	SAL	1	51.8	0.053	0.166	0.056	136		140
110	SH	DAL T	1	12.0	0.008	0.039	0.007	178		219
110	SH	IKET	1	53.7	0.034	0.175	0.019	178		219

Table B-3 Characteristics of Existing Transmission Circuits

Voltage (kV)	From	To	No.	Length (km)	Impedance on 100 MVA Base (pu)			Rating (MVA)		
					R	X	B	Summer	Autumn	Winter
110	SH	SOM T	1	13.8	0.021	0.047	0.006	105		128
110	SLI	SRA	1	11.1	0.017	0.038	0.004	99		125
110	SLI	SRA	2	12.0	0.019	0.041	0.004	99		125
110	SNG	AA	1	5.6	0.004	0.018	0.004	178		219
110	SOM	SOM T	1	2.0	0.003	0.007	0.001	105		128
110	SOR	TLK	1	4.4	0.007	0.015	0.002	105		128
110	SRA	CF	2	49.2	0.031	0.160	0.017	178		219
110	STR (I)	STR T	1	2.0	0.003	0.007	0.001	105		128
110	TAN	WAR	1	12.9	0.013	0.042	0.005	79	96	113
110	TAN	WAR	2	12.9	0.013	0.042	0.005	79	96	113
110	TB	TRL	1	42.0	0.063	0.147	0.014	99		125
110	TBK	TBK T	1	2.9	0.005	0.010	0.001	105		128
110	THU	IKE T	1	25.9	0.016	0.084	0.009	178		219
110	TRL	OUG T	1	11.3	0.007	0.037	0.004	178		219
110	TRL	TB	2	45.7	0.028	0.148	0.024	178		219

Table B-4 Characteristics of Existing Transformers in Ireland

Station	Transformer	Rating (MVA)	HV/LV (kV)	Impedance on 100 MVA Base (pu)		Voltage Ratio Tapping Range	
				R	X	+	-
DSN	T4201	500	400/220	0.000	0.032	1%	15%
DSN	T4202	500	400/220	0.0003	0.027	10%	7%
MP	T4201	500	400/220	0.000	0.033	1%	15%
OST	T4202	500	400/220	0.000	0.027	10%	7%
WOO	T4201	500	400/220	0.000	0.032	1%	15%
WOO	T4202	550	400/220	0.000	0.027	N/A	
WOO	T4204	500	400/220	0.000	0.0316	1%	15%
LOU	AT1	300	275/220	0.001	0.03	15%	15%
LOU	AT2	600	275/220	0.001	0.015	15%	15%
LOU	AT3	300	275/220	0.001	0.03	15%	15%
AD	T2102	125	220/110	0.001	0.124	10%	18%
ARK	T2101	63	220/110	0.007	0.18	23%	19%
ARK	T2102	125	220/110	0.002	0.124	9%	18%
CLA	T2101	125	220/110	0.001	0.124	9%	17%
CLA	T2102	250	220/110	0.001	0.065	9%	17%
CSH	T2101 ⁴	238	220/110	0	0.063	9%	18%
CSH	T2102	250	220/110	0	0.063	9%	18%
CSH	T2104	175	220/110	0.002	0.133	22%	18%
CKM	T2101	250	220/110	0.001	0.065	9%	17%
CKM	T2102	250	220/110	0.001	0.065	9%	17%
CKM	T2103	250	220/110	0.001	0.065	9%	17%
CUL	T2101	250	220/110	0.001	0.064	9%	18%
CDU	T2101	250	220/110	0.001	0.062	9%	17%
CDU	T2102	250	220/110	0.001	0.061	9%	17%
FLA	T2101	125	220/110	0.003	0.128	9%	18%
FLA	T2102	125	220/110	0.001	0.133	9%	18%
FIN (I)	T2101	250	220/110	0.001	0.065	9%	18%
FIN (I)	T2102	250	220/110	0.001	0.065	9%	18%
FIN (I)	T2103	250	220/110	0.001	0.064	9%	17%

4. Transformer is limited to 238 MVA at 110 kV by the 110 kV switchgear.

Table B-4 Characteristics of Existing Transformers in Ireland

Station	Transformer	Rating (MVA)	HV/LV (kV)	Impedance on 100 MVA Base (pu)		Voltage Ratio Tapping Range	
				R	X	+	-
FIN (I)	T2104	250	220/110	0.001	0.064	9%	17%
FIN (I)	T2105	250	220/110	0.001	0.064	9%	17%
GI	T2101	125	220/110	0.003	0.133	9%	18%
GI	T2102	125	220/110	0.002	0.124	22%	18%
GOR (I)	T2101	250	220/110	0.001	0.064	9%	18%
INC	T2101	250	220/110	0.001	0.0564	9%	17%
INC	T2102	250	220/110	0.001	0.0564	9%	17%
INC	T2103	250	220/110	0.0001	0.06	9%	18%
INC	T2104	250	220/110	0.0001	0.06	9%	18%
KNR	T2101	250	220/110	0.001	0.064	10%	18%
KNR	T2102	250	220/110	0.0001	0.064	10%	18%
KRA	T2101	250	220/110	0.001	0.065	9%	17%
KRA	T2102	250	220/110	0.001	0.065	9%	17%
KRA	T2103	250	220/110	0.001	0.065	9%	18%
KLN	T2101	63	220/110	0.007	0.245	22%	18%
KLN	T2102	63	220/110	0.01	0.247	22%	18%
KLN	T2103	250	220/110	0	0.063	9%	18%
KLN	T2104	120	220/110	0.001	0.123	9%	18%
KLS	T2101	125	220/110	0.001	0.124	9%	18%
KLS	T2102	125	220/110	0.001	0.124	9%	18%
LOU	T2101	125	220/110	0.002	0.133	22%	18%
LOU	T2102	125	220/110	0.002	0.132	23%	18%
LOU	T2103	125	220/110	0.002	0.132	22%	18%
LOU	T2104	250	220/110	0.001	0.064	9%	17%
LWD	T2102	250	220/110	0.001	0.064	9%	18%
MAY	T2101	125	220/110	0.002	0.134	22%	18%
MAY	T2102 ¹	238	220/110	0.001	0.064	9%	17%
MAY	T2103	125	220/110	0.002	0.132	22%	18%
MAY	T2104	250	220/110	0.001	0.064	9%	17%
PB	TF3	250	220/110	0.001	0.059	8%	17%

Table B-4 Characteristics of Existing Transformers in Ireland

Station	Transformer	Rating (MVA)	HV/LV (kV)	Impedance on 100 MVA Base (pu)		Voltage Ratio Tapping Range	
				R	X	+	-
PB	TF4	250	220/110	0.001	0.061	8%	17%
RAF	T2101 ¹	238	220/110	0.001	0.064	9%	17%
RAF	T2102	250	220/110	0	0.056	9%	17%
SH	T2101	125	220/110	0.006	0.124	9%	18%
SH	T2102	125	220/110	0.001	0.124	9%	18%
SRA	T2101	250	220/110	0.001	0.064	9%	18%
TB	T2101 ¹	238	220/110	0.001	0.055	9%	17%
TB	T2102 ¹	238	220/110	0.001	0.055	9%	17%

Table B-5 Characteristics of Existing Transformers in Northern Ireland

Substation/ Transformer	HV/ LV	Impedance pu on 100 MVA base						Rating (MVA)			Off Nominal Ratio (pu)		No. of Taps
		W1-2		W2-3		W3-1		W1	W2	W3	Upper	Lower	
		R	X	R	X	R	X						
BPS IBTx 1	275/ 110	0.0018	0.0641	0.0018	0.2092	0	0.1325	240	240	30	1.15	0.85	19
BPS IBTx 2	275/ 110	0.0018	0.0641	0.0018	0.2059	0	0.128	240	240	30	1.15	0.85	19
CAS IBTx 1	275/ 110	0.0018	0.0641	0.0018	0.2092	0	0.1325	240	240	60	1.15	0.85	19
CAS IBTx 2	275/ 110	0.0014	0.0639	0.0014	0.2236	0	0.1449	240	240	30	1.15	0.85	19
CAS IBTx 3	275/ 110	0.0018	0.0656	0.0018	0.2375	0	0.1593	240	240	30	1.15	0.85	19
CPS IBTx 1	275/ 110	0.0018	0.0609	0.0018	0.1273	0	0.057	240	240	60	1.15	0.85	19
CPS IBTx 2	275/ 110	0.0014	0.0639	0.0014	0.2236	0	0.1449	240	240	30	1.15	0.85	19
HAN IBTx 1	275/ 110	0.0018	0.0591	0.0018	0.1261	0	0.056	240	240	45	1.15	0.85	19
HAN IBTx 2	275/ 110	0.0018	0.0591	0.0018	0.1261	0	0.056	240	240	45	1.15	0.85	19
HAN IBTx 3	275/ 110	0.0014	0.0639	0.0014	0.2236	0	0.1449	240	240	60	1.15	0.85	19
KEL IBTx 1	275/ 110	0.0018	0.0609	0.0018	0.1273	0	0.057	240	240	45	1.15	0.85	19
KEL IBTx 2	275/ 110	0.0018	0.0607	0.0018	0.1317	0	0.057	240	240	45	1.15	0.85	19
TAN IBTx 1	275/ 110	0.0018	0.0641	0.0018	0.2092	0	0.1325	240	240	30	1.15	0.85	19
TAN IBTx 2	275/ 110	0.0018	0.0641	0.0018	0.2092	0	0.1325	240	240	30	1.15	0.85	19
TAN IBTx 3	275/ 110	0.0014	0.0639	0.0018	0.2375	0	0.1575	240	240	60	1.15	0.85	19
TAN IBTx 1	275/ 110	0.0014	0.0656	0.0018	0.2375	0	0.1449	240	240	60	1.15	0.85	19
KPS IBTx 1	275/ 11.5	0	0.1635	0	0.3040	0	0.1635	110	55	55	1.15	0.938	33

Table B-6 Characteristics of Existing Power Flow Controllers

Station	Voltage (kV)	Circuit	Rating (MVA)	Impedance on 100 MVA Base (pu)		Phase Angle Range (electrical degrees)	
				R	X	+	-
CKM	220	CKM – PB	350	0.000	0.029	15.3	15.3
ENN (N)	110	ENNK – COR	125	0.000	0.0213	1.2	0.8
STR (N)	110	STRA – LET	125	0.000	0.0213	1.2	0.8

Table B-7 Characteristics of Existing Reactive Compensation

Station	Voltage (kV)	Plant	Capability (Mvar)	
			Generate	Absorb
ARD	110	1 Capacitor	30	
ATH	110	2 Capacitors (1 Mobile)	60	
BAN (I)	110	1 Capacitor	15	
BYC	275	4 Capacitors (4 x 59)	236	
CAH	110	4 Capacitors (4 x 15)	60	
CAS	22	3 Capacitors (3 x 25)	75	
CAS	22	1 Shunt Reactor		30
CBR	110	1 Capacitor	30	
CBR	110	1 Static Var Compensator	60	10
CF	110	1 Capacitor	15	
CKM	220	1 Shunt Reactor		100
COL (N)	110	1 Capacitor	36	
CPS	110	1 Capacitor	40	
CSH	110	2 Capacitors (2 x 40)	80	
DLN	33	1 Capacitor	5	
DLT	110	1 Capacitor	15	
DMY	110	1 Capacitor	15	
DOO	110	1 Capacitor	15	
DRU (I)	110	1 Capacitor	15	
DSN	400	1 Shunt Reactor		80
ENN (N)	33	4 Capacitors (4 x 6)	24	
GWE	110	1 Capacitor	15	
HAN	22	2 Shunt Reactors (2 x 30)		60
KEL	22	2 Shunt Reactors (2 x 30)		60
KKY	110	2 Capacitor (2 x 15)	30	
KTL	10	1 Capacitor	30	
LET	110	2 Capacitor (1 Mobile)	45	
LET	110	1 Static Var Compensators	30	
LIS (I)	110	2 Capacitors (2 x 15)	30	
LOU	110	1 Capacitor	30	

Table B-7 Characteristics of Existing Reactive Compensation

Station	Voltage (kV)	Plant	Capability (Mvar)	
			Generate	Absorb
MOY	110	2 Capacitors (2 x 15)	30	
MUL	110	2 Capacitors (2 x 15)	30	
NAV	110	1 Capacitor (1 Mobile)	30	
POR	400	EWIC HVDC	175	175
RAF	110	1 Capacitor	60	
SKL	110	1 Capacitor (1 Mobile)	30	
SLI	110	1 Capacitor	15	
SLK	20	1 Capacitor	13	
TAN	22	2 Capacitors (2 x 25)	50	
TAN	22	2 Shunt Reactors (2 x 30)		60
THU	110	2 Capacitor (2 x 15)	30	
TRI	110	1 Capacitor	30	
TRL	110	1 Capacitor	30	
WEX	110	2 Capacitors (2 x 15)	30	
WOO	400	1 Shunt Reactor		80

B.2 Transmission System Developments

Future developments of the transmission system are listed in this section according to the year in which they are expected to be completed. The network changes related to each development project are grouped together and collectively headed by a Capital Project (CP) number and title. The physical and electrical characteristics of future transmission plant or changes to the characteristics brought about by planned developments are listed in the tables. These characteristics are indicative at this stage and will be reviewed when the item of plant is commissioned.

Table B-8 Expected Changes in Circuit Characteristics

Action	Voltage (kV)	From	To	No.	Length (km)	Impedance on 100 MVA Base (pu)			Rating (MVA)		Year
						R	X	B	Summer	Winter	
Add	110	BVK	GRO	1	4.9	0.002	0.002	0.033	195	220	2016
Add	220	BVK	CLA	1	18.4	0.002	0.002	0.054	761	804	2016
Add	220	BVK	BYH	1	14.5	0.002	0.012	0.054	761	660	2016
Add	110	CLG	CDU	1	2.5	0.001	0.003	0.028	187	219	2016
Add	110	CF	CLO	2	25.9	0.037	0.094	0.009	187	222	2016
Add	110	SCR	KNY	1	33.3	0.033	0.106	0.042	136	140	2016
Add	110	KNY	UGL	1	3.4	0.001	0.004	0.047	228	228	2016
Add	110	KNY	GAL	1	26.5	0.005	0.031	0.363	228	228	2016
Add	110	KNY	SAL	1	28.3	0.019	0.063	0.081	187	223	2016
Add	110	DRM	CLO	1	27	0.039	0.091	0.015	103	128	2016
Add	110	FLA	SLB	1	21.7	0.034	0.075	0.007	105	128	2016
Add	110	FRA	TRN	1	2.8	0.002	0.004	0.028	140	140	2016
Add	110	CLO	MRY	1	7.4	0.005	0.011	0.074	124	124	2016
Add	110	CLO	CF	1	26.5	0.016	0.085	0.016	178	219	2016
Add	110	CLO	GL T	1	0.3	0.000	0.001	0.001	187	222	2016
Add	220	KNR	BYH	1	47	0.006	0.040	0.064	761	660	2016
Add	110	BYH	GLE	1	12.5	0.005	0.024	0.244	178	219	2016
Add	110	KIN	MUL	1	27	0.017	0.088	0.010	178	219	2016
Add	110	MHL	TRN	1	1.4	0.001	0.002	0.014	140	140	2016
Add	110	BNM	DON	1	-	0.005	0.005	0.053	75	82	2016
Add	110	BNM	DON	1	-	0.005	0.005	0.053	75	82	2016
Add	110	COL (N)	RSK	1	-	0.024	0.069	0.007	185	193	2016
Add	110	CRG	TMN	1	-	0.045	0.119	0.022	109	124	2016
Add	110	DRU	TMN	1	-	0.028	0.073	0.012	82	103	2016

Table B-8 Expected Changes in Circuit Characteristics

Action	Voltage (kV)	From	To	No.	Length (km)	Impedance on 100 MVA Base (pu)			Rating (MVA)		Year
						R	X	B	Summer	Winter	
Add	110	DRU	TMN	2	-	0.029	0.075	0.008	82	103	2016
Add	110	DUN	TMN	1	-	0.004	0.017	0.005	139	152	2016
Add	110	DUN	TMN	2	-	0.009	0.023	0.002	139	152	2016
Add	110	DUN	OMA	1	-	0.042	0.124	0.012	186	193	2016
Add	110	DUN	TMN	3	-	0.004	0.020	0.019	186	193	2016
Add	110	GOR (N)	OMA	1	-	0.011	0.066	0.006	188	213	2016
Add	110	GOR (N)	TMN	1	-	0.021	0.131	0.013	188	213	2016
Add	110	KEL	RSK	1	-	0.039	0.133	0.013	185	193	2016
Add	275	MAG	TMN	2	-	0.001	0.011	0.065	710	881	2016
Add	110	OMA	TRE	1	-	0.025	0.073	0.007	186	193	2016
Add	275	TAN	TMN	2	-	0.002	0.011	0.065	710	881	2016
Add	110	TRE	TMN	1	-	0.025	0.082	0.025	186	193	2016
Remove	220	CLA	KNR	1	2016
Remove	110	CF	DRM	1	2016
Remove	110	CF	GL T	1	2016
Remove	110	SCR	SAL	1	2016
Remove	110	FLA	LA	1	2016
Remove	110	FRA	MHL	1	2016
Remove	110	COL (N)	KEL	1	2016
Remove	110	CRG	DUN	1	2016
Remove	110	DON	PSW	1	2016
Remove	110	DON	PSW	1	2016
Remove	110	DRU	DUN	1	2016
Remove	110	DRU	DUN	2	2016
Remove	110	DUN	OMA	1	2016
Remove	110	DUN	OMA	2	2016
Remove	110	DUN	TMN	1	2016
Remove	275	MAG	TAN	1	2016
Add	110	BGD	INC	1	6.5	0.005	0.010	0.065	140	140	2017

Table B-8 Expected Changes in Circuit Characteristics

Action	Voltage (kV)	From	To	No.	Length (km)	Impedance on 100 MVA Base (pu)			Rating (MVA)		Year
						R	X	B	Summer	Winter	
Add	110	BGD	INC	2	6.5	0.005	0.010	0.065	140	140	2017
Add	110	AGY	TIV	1	35	0.054	0.120	0.011	105	128	2017
Amend	110	ARV	SKL	1	...	0.029	0.065	0.006	137	137	2017
Add	110	AUG	KPG	1	32.8	0.021	0.107	0.012	178	219	2017
Remove	110	AUG	TB	1	2017
Remove	110	BIN	LET	1	2017
Add	110	BIN	TIV	1	23.2	0.024	0.077	0.008	136	166	2017
Amend	110	BK	CBR	1	...	0.058	0.128	0.013	195	221	2017
Amend	110	BOL	TK T	1	...	0.031	0.067	0.006	178	219	2017
Add	110	BRO	RSK	1	-	0.010	0.062	0.020	178	219	2017
Add	110	CDL	BYH	1	9	0.002	0.010	0.099	209	223	2017
Remove	220	CDU	WOO	1	2017
Amend	110	CDY	AG T	1	...	0.014	0.046	0.005	178	219	2017
Add	110	CLA	DMY	1	35	0.022	0.114	0.012	178	219	2017
Add	220	CLE	CDU	1	40	0.005	0.035	0.052	434	534	2017
Add	220	CLE	WOO	1	40	0.005	0.035	0.052	434	534	2017
Amend	110	COS	AG T	1	...	0.022	0.069	0.007	178	219	2017
Add	110	CTG	BVK	1	31.7	0.006	0.036	0.386	228	228	2017
Amend	110	CTN	TIP	1	...	0.021	0.046	0.004	178	219	2017
Add	110	CTR	GOR (I)	1	14	0.003	0.015	0.154	187	223	2017
Add	110	DMY	BDV	1	15.6	0.022	0.057	0.005	187	223	2017
Remove	110	DMY	MAC	1	2017
Add	110	ENN (I)	SLC	1	20	0.005	0.022	0.221	192	192	2017
Add	110	FIN (I)	KLM	1	9.3	0.005	0.010	0.056	140	143	2017
Add	110	GLT	BYH	1	9.3	0.006	0.030	0.003	178	219	2017
Add	110	KCR	GLE (I)	1	11.2	0.008	0.017	0.115	140	140	2017
Add	110	KNR	KPG	1	15	0.015	0.050	0.005	136	166	2017
Add	220	KNR	KPG	1	21.4	0.003	0.015	0.054	660	660	2017
Remove	110	KNR	TB	1	2017

Table B-8 Expected Changes in Circuit Characteristics

Action	Voltage (kV)	From	To	No.	Length (km)	Impedance on 100 MVA Base (pu)			Rating (MVA)		Year
						R	X	B	Summer	Winter	
Remove	220	KNR	TB	1	2017
Add	110	KNY	BUF	1	0.5	0.000	0.001	0.006	140	140	2017
Add	110	KNY	KLH	1	9.9	0.002	0.011	0.110	190	190	2017
Add	220	KPG	MP	1	5.4	0.000	0.002	0.236	660	660	2017
Add	110	KPG	RAT (I)	1	32.2	0.033	0.108	0.011	136	166	2017
Add	110	KPG	TB	1	1.6	0.002	0.006	0.001	120	128	2017
Add	220	KPG	TB	1	2.8	0.000	0.002	0.026	761	802	2017
Add	110	KPG	TB	2	1.6	0.002	0.006	0.001	120	128	2017
Add	110	KPG	TRL	1	39.4	0.060	0.135	0.013	105	128	2017
Add	110	KPG	TRL	2	44.4	0.028	0.144	0.016	178	219	2017
Add	110	LET	TIV	1	45.2	0.047	0.151	0.015	136	166	2017
Add	220	LOU	ORL	1	14.5	0.002	0.013	0.019	434	534	2017
Remove	220	LOU	WOO	1	2017
Add	110	MAC	BDV	1	10.6	0.015	0.039	0.004	187	222	2017
Add	110	MLC	TSB	1	19.2	0.012	0.063	0.007	178	219	2017
Amend	110	MP	TK T	1	...	0.010	0.023	0.002	178	219	2017
Add	220	ORL	ORL L	1	20.1	0.001	0.008	0.550	593	593	2017
Add	220	ORL L	ORL O	1	15.9	0.001	0.002	0.528	570	570	2017
Amend	110	RAF	TBG	1	...	0.016	0.036	0.005	178	219	2017
Remove	110	RAT	TB	1	2017
Add	220	TB	KPG	1	2.8	0.000	0.002	0.028	660	660	2017
Remove	110	TB	TRL	1	2017
Remove	110	TRL	TB	2	2017
Add	220	WOO	ORL	1	49.2	0.006	0.043	0.064	434	534	2017
Add	110	BKM	CUR	1	7.3	0.004	0.007	0.072	120	120	2018
Add	220	BLC	FIN (I)	1	10	0.000	0.002	0.332	570	570	2018
Add	110	BLC	GRA	1	4.3	0.003	0.005	0.031	140	140	2018
Add	110	BLC	KLM	1	4	0.002	0.005	0.029	140	140	2018
Add	110	BRA	NEW (I)	1	9.3	0.010	0.031	0.003	136	166	2018

Table B-8 Expected Changes in Circuit Characteristics

Action	Voltage (kV)	From	To	No.	Length (km)	Impedance on 100 MVA Base (pu)			Rating (MVA)		Year
						R	X	B	Summer	Winter	
Add	110	BRA	PLS	1	19.3	0.030	0.067	0.006	105	128	2018
Add	110	CURT	BKM	1	17.3	0.004	0.019	0.192	190	190	2018
Add	110	CURT	NEN	1	18.8	0.029	0.065	0.006	105	128	2018
Remove	110	ENN (N)	OMA	1	2018
Remove	110	ENN (N)	OMA	2	2018
Remove	110	FIN (I)	GRA	1	2018
Add	110	KBY	KBY	1	0.2	0.000	0.000	0.002	130	130	2018
Add	110	KLN	CURT	1	14.8	0.011	0.048	0.005	136	166	2018
Remove	110	KLN	NEN	1	2018
Add	110	MAC	CLA	2	9	0.002	0.010	0.099	192	192	2018
Remove	110	NEW	PLS	1	2018
Add	110	OMS	CMK	1	8.6	0.007	0.045	0.004	167	188	2018
Add	110	OMS	ENN (N)	1	23.8	0.026	0.066	0.007	82	103	2018
Add	110	OMS	ENN (N)	2	23.7	0.026	0.066	0.007	82	103	2018
Add	110	OMS	OMA	1	10	0.018	0.047	0.005	82	103	2018
Add	110	OMS	OMA	2	10	0.018	0.047	0.005	82	103	2018
Add	110	AIR	ROS	1	-	0.009	0.022	0.004	82	103	2019
Add	110	AIR	ROS	1	-	0.009	0.022	0.004	82	103	2019
Add	110	ATE	KNR	1	9.0	0.006	0.029	0.003	178	219	2019
Add	110	ATY	LSE	1	21.9	0.014	0.071	0.008	178	219	2019
Remove	110	ATY	PLS	1	2019
Add	110	BGT	KKY	1	22	0.014	0.072	0.008	178	219	2019
Add	110	BGT	LSE	1	28	0.018	0.091	0.010	178	219	2019
Amend	110	BK	MOY	1	...	0.017	0.088	0.010	137	137	2019
Add	275	BPS	-	1	-	0.000	0.000	0.032	366	366	2019
Add	275	BPS	-	1	-	0.000	0.000	0.032	366	366	2019
Add	110	BRO	GAR (N)	1	-	0.003	0.016	0.005	178	219	2019
Remove	110	BRO	RSK	1	2019
Amend	220	BVK	BYH	1	...	0.002	0.012	0.054	761	804	2019

Table B-8 Expected Changes in Circuit Characteristics

Action	Voltage (kV)	From	To	No.	Length (km)	Impedance on 100 MVA Base (pu)			Rating (MVA)		Year
						R	X	B	Summer	Winter	
Remove	110	CKG	BKY	1	2019
Add	110	CKG	WDU	1	0.8	0.000	0.001	0.008	187	223	2019
Add	110	CKG	WDU	2	0.8	0.000	0.001	0.008	187	223	2019
Amend	275	CPS	MAG	1	...	0.006	0.025	0.151	1000	1000	2019
Amend	275	CPS	MAG	1	...	0.006	0.025	0.151	1000	1000	2019
Add	110	CRF	CLO	1	18	0.011	0.059	0.006	178	219	2019
Add	400	DSN	LSE	1	44.8	0.001	0.010	0.226	1577	1944	2019
Remove	400	DSN	MP	1	2019
Add	110	GAR (N)	RSK	1	-	0.010	0.059	0.017	178	219	2019
Add	110	GCA	INC	3	7.7	0.005	0.004	0.094	124	124	2019
Remove	110	GCA	KUD	1	2019
Remove	110	GCA	KUD	2	2019
Remove	110	INC	BKY	1	2019
Remove	220	INC	MAY	2	2019
Add	220	INC	WDU	2	14.3	0.002	0.012	0.020	761	804	2019
Add	220	KLN	KPG	1	70.6	0.009	0.061	0.114	434	534	2019
Remove	220	KLN	TB	1	2019
Amend	220	KNR	BYH	1	...	0.006	0.040	0.064	761	804	2019
Add	220	KNR	KPG	2	20	0.000	0.010	0.971	660	660	2019
Add	220	KPG	MP	2	5.4	0.000	0.002	0.236	660	660	2019
Add	110	KUD	WDU	1	0.8	0.000	0.001	0.008	187	223	2019
Add	110	KUD	WDU	2	0.8	0.000	0.001	0.008	187	223	2019
Add	400	LSE	MP	1	170	0.003	0.038	0.858	1577	1944	2019
Add	110	LSE	PLS	1	8.4	0.005	0.026	0.008	178	219	2019
Remove	220	MAY	INC	1	2019
Amend	110	MOY	GLR	1	...	0.022	0.048	0.005	105	128	2019
Add	110	NMO	BK	1	3.3	0.002	0.011	0.001	178	219	2019
Add	110	NMO	BK	2	3.3	0.002	0.011	0.001	178	219	2019
Add	110	NMO	BK	3	14.1	0.009	0.046	0.005	178	219	2019

Table B-8 Expected Changes in Circuit Characteristics

Action	Voltage (kV)	From	To	No.	Length (km)	Impedance on 100 MVA Base (pu)			Rating (MVA)		Year
						R	X	B	Summer	Winter	
Add	110	NMO	BK	4	38.5	0.024	0.125	0.014	178	219	2019
Add ¹	400	NMO	FLA	1	115	0.002	0.027	0.621	1577	1944	2019
Add ²	220	SRA	FLA 1	1	47	0.005	0.041	0.061	434	353	2019
		FLA 1	FLA	1	8	0.000	0.003	0.324	680	680	2019
		NMO	NMO 1	1	2	0.000	0.001	0.081	680	680	2019
		NMO 1	NMO 2	1	11	0.001	0.010	0.014	434	535	2019
		NMO 2	NMO 3	1	20	0.001	0.009	0.809	680	680	2019
		NMO 3	FLA	1	72	0.008	0.062	0.094	434	535	2019
Add ³	320	NMO	FLA	1	112.5	500	500	2019
Amend	110	OMS	OMA	1	10	0.018	0.047	0.005	186	195	2018
Amend	110	OMS	OMA	2	10	0.018	0.047	0.005	186	195	2018
Remove	275	TAN	TMN	1	2019
Remove	275	TAN	TMN	2	2019
Add	275	TAN	TUR	1	-	0.001	0.009	0.051	710	881	2019
Add	275	TAN	TUR	2	-	0.001	0.009	0.051	710	881	2019
Add	275	TMN	TUR	1	-	0.000	0.002	0.014	710	881	2019
Add	275	TMN	TUR	2	-	0.000	0.002	0.014	710	881	2019
Add	110	WDU	BKY	1	1	0.000	0.001	0.011	187	223	2019
Add	110	WDU	BKY	2	0.6	0.000	0.001	0.011	187	223	2019
Add	220	WDU	INC	1	14.3	0.002	0.009	0.014	761	804	2019
Add	220	WDU	MAY	1	11.7	0.002	0.012	0.018	761	804	2019
Add	220	WDU	MAY	2	11.7	0.002	0.010	0.016	761	804	2019
Add	110	ARM	TAN	1	-	0.024	0.057	0.007	82	103	> 2019
Add	110	ARM	TAN	1	-	0.024	0.057	0.007	82	103	> 2019
Add	110	BK	SKY	1	4	0.001	0.004	0.044	187	223	> 2019
Add	110	BLC	DTN	1	8	0.004	0.009	0.049	140	143	> 2019
Add	220	BLC	SHL	1	23.4	0.001	0.003	0.777	570	570	> 2019
Add	110	BLP	KBY	1	0.2	0.000	0.000	0.002	124	124	> 2019

1. Grid West 400 kV overhead line option.
2. Grid West 220 kV partial cable option.
3. Grid West 320 kV HVDC option (generic model provided).

Table B-8 Expected Changes in Circuit Characteristics

Action	Voltage (kV)	From	To	No.	Length (km)	Impedance on 100 MVA Base (pu)			Rating (MVA)		Year
						R	X	B	Summer	Winter	
Add	110	CAM	COL (N)	1	-	0.027	0.080	0.008	185	193	> 2019
Add	110	CAM	CPS	1	-	0.027	0.080	0.008	181	193	> 2019
Add ⁴	110	CBR	MOY	1	37	0.023	0.120	0.013	178	219	> 2019
Add ⁵	110	CBR	MOY1	1	11	0.001	0.017	0.134	295	295	> 2019
		MOY1	CBR	1	26	0.016	0.084	0.092	178	219	> 2019
Add ⁶	220	CLO	SRA	1	83	0.010	0.072	0.109	434	534	> 2019
Add ⁷	220	CLO	CLO1	1	25	0.001	0.010	0.684	593	593	> 2019
		CLO1	SRA	1	58	0.007	0.050	0.076	434	534	> 2019
Amend	110	COL (N)	CPS	1	...	0.061	0.161	0.015	185	193	>2019
Amend	110	COL (N)	LIM (N)	1	...	0.024	0.064	0.006	185	193	>2019
Amend	110	CPS	KMT	1	...	0.011	0.048	0.005	186	193	>2019
Amend	110	CPS	LIM (N)	1	...	0.039	0.101	0.010	185	193	>2019
Amend	110	CPS	STR (N)	1	...	0.018	0.053	0.017	185	193	>2019
Amend ⁸	220	DSN	MAY	2	30.6	0.004	0.027	0.040	434	534	> 2019
Add	400	DSN	WOO	1	58	0.001	0.013	0.293	1577	1944	> 2019
Remove	220	GOR (I)	MAY	1	> 2019
Add	220	GOR (I)	WOO	1	27	0.003	0.036	0.144	434	534	> 2019
Remove	110	DTN	FIN (I)	1	> 2019
Remove	220	FIN (I)	SHL	1	> 2019
Add	110	KEL	RSK	2	-	0.022	0.134	0.013	188	213	> 2019
Add	110	KEL	TID	1	-	0.035	0.192	0.019	309	309	> 2019
Add	110	KEL	KEL 1	2	-	0.005	0.031	0.003	126	156	> 2019
Add	110	KEL1	KEL2	3	-	0.000	0.001	0.008	144	144	> 2019
Amend	110	KMT	STR (N)	1	...	0.008	0.037	0.004	185	193	>2019
Add	110	KPG	CH	1	22.6	0.024	0.075	0.008	136	166	> 2019
Add	400	KPN	MP	1	5.5	0.001	0.000	0.549	1210	1210	> 2019

4. North Connaught Reinforcement 110 kV overhead line option.
 5. North Connaught Reinforcement 110 kV partial cable option (generic model provided).
 6. North West project 220 kV overhead line option.
 7. North West project 220 kV partial cable option (generic model provided).
 8. The need for reinforcement of the Dunstown-Woodland corridor has been confirmed. However this project is in the early stage of the network development process. As such, reinforcement options have not been fully investigated and assessed. The amendments to the network described above are included only to create a stable base case for network analysis and do not represent a preferred option for this development.

Table B-8 Expected Changes in Circuit Characteristics

Action	Voltage (kV)	From	To	No.	Length (km)	Impedance on 100 MVA Base (pu)			Rating (MVA)		Year
						R	X	B	Summer	Winter	
Amend	400	LSE	MP	1	170	0.003	0.011	0.858	1577	1944	>2019
Amend	400	DSN	LSE	1	0.003	>2019
Add	110	OMA	NST	1	-	0.023	0.061	0.006	109	124	> 2019
Add	110	OMA	NST	2	-	0.024	0.062	0.006	82	103	> 2019
Remove	110	OMA	STR (N)	1	> 2019
Remove	110	OMA	STR (N)	2	> 2019
Amend	400	OST	WOO	1008	> 2019
Add	110	STR (N)	NST	1	-	0.023	0.061	0.006	109	124	> 2019
Add	110	STR (N)	NST	2	-	0.024	0.062	0.006	82	103	> 2019
Add	400	WOO	TUR	1	106	0.003	0.031	0.707	1424	1731	> 2019

Table B-9 Characteristics of Transformer Changes in Ireland

Action	Station	Transformer	Rating (MVA)	HV/ LV (kV)	Impedance on 100 MVA Base (pu)		Voltage Ratio Tapping Range		Year
					R	X	+	-	
Add	BVK	T2101	250	220/110	0.0010	0.0640	0.09	0.17	2016
Add	BVK	T2102	250	220/110	0.0010	0.0640	0.09	0.17	2016
Add	BYH	T2101	250	220/110	0.0010	0.0640	0.09	0.17	2016
Add	BYH	T2102	250	220/110	0.0010	0.0640	0.09	0.17	2016
Add	CKM	T2104	250	220/110	0.0004	0.0631	0.09	0.18	2017
Add	KPG	T2101	250	220/110	0.0004	0.0631	0.09	0.18	2017
Add	KPG	T2102	250	220/110	0.0004	0.0631	0.09	0.18	2017
Add	BLC	T2101	250	220/110	0.0010	0.0646	0.09	0.17	2018
Add	FLA	T4201	500	400/220	0.0003	0.0270	0.10	0.07	2019
Add	LSE	T4101	250	400/110	0.0005	0.0720	0.15	0.15	2019
Add	LSE	T4102	250	400/110	0.0005	0.0720	0.15	0.15	2019
Add	MP	T2101	250	220/110	0.0010	0.0640	0.09	0.18	2019
Add	MP	T4201	500	400/220	0.0003	0.0270	0.10	0.07	2019
Add	NMO	T4101	500	400/110	0.0005	0.0360	0.15	0.15	2019
Add	WDU	T2101	250	220/110	0.0010	0.0646	0.09	0.17	2019
Add	WDU	T2102	250	220/110	0.0010	0.0646	0.10	0.10	2019
Add	WDU	T2103	250	220/110	0.0010	0.0646	0.10	0.10	2019
Add	BLC	T2102	250	220/110	0.0010	0.0646	0.09	0.17	>2019
Add	CLO	T2101	250	220/110	0.0004	0.0631	0.09	0.18	>2019
Add	CLO	T2102	250	220/110	0.0004	0.0631	0.09	0.18	>2019
Remove	KLN	T2101	250	220/110	0.0004	0.0631	0.09	0.18	>2019
Remove	KLN	T2102	250	220/110	0.0004	0.0631	0.09	0.18	>2019
Add	KPG	T4101	500	400/220	0.0003	0.0270	0.10	0.07	>2019
Remove	KRA	T2103	250	220/110	0.0013	0.0647	0.09	0.17	>2019

Table B-10 Expected Changes in the Characteristics of Transformers in Northern Ireland

Action	Substation/ Transformer	Impedance pu on 100 MVA base						Rating (MVA)			Off Nominal Ratio (pu)		No. of Taps	Year
		W1-2		W2-3		W3-1		W1	W2	W3	Upper	Lower		
		R	X	R	X	R	X							
Add	TMN IBTx2	0.0014	0.0644	0.004	0.2299	0.0000	0.15	240	240	60	1.15	0.85	19	2016
Add	CAE IBTx1	0.0000	0.0647	0.0000	0.1203	0.0000	0.0647	224	224	60	1.1	0.9	19	2019
Add	CAE IBTx2	0.0000	0.0647	0.0000	0.1203	0.0000	0.0647	224	224	60	1.1	0.9	19	2019
Add	TUR IBTx1	0.0008	0.015	0.0000	0.0001	0.0000	0.0001	600	600	60	1.1	0.9	23	2019
Add	TUR IBTx2	0.0008	0.015	0.0000	0.0001	0.0000	0.0001	600	600	60	1.1	0.9	23	2019
Add	TUR IBTx3	0.0008	0.015	0.0000	0.0001	0.0000	0.0001	600	600	60	1.1	0.9	23	2019

Table B-11 Expected Changes in the Characteristics of Reactive Compensation

Action	Station	Voltage	Plant	Mvar Capability		Year
				Generate	Absorb	
Add	KNY	110	1 Capacitor	30		2016
Add	CTR	110	1 Capacitor	15		2017
Add	PB	220	2 Reactor (2 x 50)		100	2017
Remove	COL (N)	110	1 Capacitor	36		>2019
Add	COL (N)	110	SVC	150	150	>2019
Add	KNR	220	Reactor		50	>2019
Add	OMA	110	SVC	120	120	>2019
Add	BVK	110	Statcom	100	100	>2019
Add	BYH	110	Statcom	100	100	>2019
Remove	THU	110	2 Capacitor (2 x 15)	30		>2019
Add	THU	110	Statcom	30	30	>2019
Add	TMN	110	SVC	200	200	>2019



All-Island Ten Year

Transmission Forecast
Statement **2016**

Appendix C

Appendix C: Demand Forecasts at Individual Transmission Interface Stations

Transmission Interface Stations and Bulk Supply Points are connection points to the transmission system. These connection points include transmission system connections to the distribution system or directly-connected customers. Table C-1 to Table C-4 list the demand forecasts at each Transmission Interface Station and Bulk Supply Point. The forecasts are noted for each node between 2016 and 2025 at the winter peak, summer peak, and summer valley. The autumn peak forecasts are also given for Northern Ireland.

The station demand values do not include transmission losses. Demand values at stations that interface with the distribution system do include distribution losses.

Transmission Interface Stations are generally 110 kV stations. The exceptions to this are four 220 kV interface stations that supply the Dublin City networks. These four interface stations, namely Carrickmines, Finglas, Inchicore and Poolbeg, are operated by the DSO of Ireland.

Only stations feeding demand (generation stations are not included) are included in the tables below.

Table C-1 Demand Forecasts at Time of Winter Peak

Bus Code	Bus Name	Power Factor	Demand Forecast (MW)									
			2016	2017	2018	2019	2020	2021	2022	2023	2024	2025
AA	Ardnacrusha	0.98	33.7	33.6	32.9	33.2	33.6	33.9	34.5	35.1	35.7	36.3
AD	Aghada	0.95	1.7	1.69	1.66	1.67	1.69	1.71	1.74	1.77	1.8	1.83
AGH	Aghyoule	0.99	16.9	17.1	17.3	17.5	17.8	18	18.2	18.5	18.7	19
AGY	Ardnagappary	0.95	0	15.3	15	15.1	15.2	15.4	15.7	16	16.2	16.5
AHA	Ahane	0.99	4.45	4.44	4.34	4.38	4.43	4.48	4.55	4.64	4.72	4.8
AIR	Belfast - Airport Road Main	0.97	-	-	-	22.3	22.4	22.5	22.6	22.6	22.7	22.8
ANR	Anner	0.9	14	14	14	14	14	14	14	14	14	14
ANT	Antrim Main	0.98	41.7	41.8	41.8	41.9	42.1	42.3	42.5	42.7	42.9	43.2
ARI	Arigna	0.82	4.55	4.54	4.45	4.48	4.53	4.58	4.66	4.74	4.83	4.91
ARK	Arklow	1	37	36.8	27.2	27.4	27.8	28.1	28.5	29.1	29.6	30.1
ARM	Armagh	0.97	-	-	-	-	-	45.2	45.4	45.6	45.8	46.1
ATH	Athlone	0.98	65.8	65.6	64.2	64.8	65.5	66.2	67.3	68.5	69.8	70.9
ATY	Athy	0.93	18.1	18	17.6	17.8	18	18.2	18.5	18.8	19.2	19.5
BAL	Baltrasna	0.98	14	13.9	13.6	13.7	13.9	14	14.3	14.5	14.8	15
BAN (N)	Banbridge Main	0.98	39.9	39.9	39.9	39.9	40	40	40.1	40.2	40.3	40.5
BAN (I)	Bandon	0.97	55.2	55.1	54	54.4	55	55.5	56.5	57.4	58.4	59.4
BAR	Barrymore	0.98	26.1	26	25.5	25.7	26	26.2	26.7	27.2	27.7	28.1
BDA	Baroda	0.99	5.26	5.26	5.26	5.26	5.26	5.26	5.26	5.26	5.26	5.26
BDN	Ballydine	0.97	17.1	17.1	16.9	16.9	17.1	17.2	17.4	17.6	17.8	18
BEG	Ballybeg	0.99	13.7	13.6	13.4	13.5	13.6	13.8	14	14.2	14.5	14.7
BGD	Belgard	0.95	-	63.00	63.00	63.00	63.00	63.00	63.00	63.00	63.00	63.00
BGT	Ballyrag	0.95	0	0	0	24.7	25	25.3	25.7	26.2	26.7	27.1
BIN	Binbane	0.88	25.4	15.1	14.8	14.9	15.1	15.2	15.5	15.8	16	16.3
BK	Bellacorick	0.95	5.71	5.69	5.57	5.62	5.68	5.74	5.84	5.95	6.05	6.15
BKY	Barnakyle	0.95	9.79	9.76	9.55	9.63	9.74	9.84	10	10.2	10.4	10.6
BLI	Ballylickey	0.72	15.7	15.6	15.3	15.4	15.6	15.7	16	16.3	16.6	16.9
BLK	Blake	0.98	26.1	26	12.4	12.5	12.6	12.7	13	13.2	13.4	13.7
BMA	Ballymena Main	0.96	85.3	85.5	85.6	85.9	86.2	86.6	86.9	87.4	87.9	88.3
BNH	Ballynahinch Main	0.99	60.4	60.4	60.3	60.4	60.5	60.5	60.7	60.8	61	61.1
BNM	Belfast - Belfast North Main	0.96	50	49.9	54.1	54.4	54.8	55.2	55.5	55.9	56.3	56.7

Table C-1 Demand Forecasts at Time of Winter Peak

Bus Code	Bus Name	Power Factor	Demand Forecast (MW)									
			2016	2017	2018	2019	2020	2021	2022	2023	2024	2025
BOG	Banoge	0.96	5.36	5.34	21	21.2	21.4	21.7	22	22.4	22.8	23.2
BRA	Bracklon	0.95	0	0	13.1	13.2	13.3	13.5	13.7	14	14.2	14.4
BRI	Brinny	0.97	3.95	3.95	3.95	3.95	3.95	3.95	3.95	3.95	3.95	3.95
BRY	Barnahely	0.95	30.8	30.7	30.1	30.3	30.7	31	31.5	32.1	32.7	33.2
BUT	Butlerstown	0.99	32.7	32.6	31.9	32.2	32.6	32.9	33.5	34.1	34.7	35.2
CAH	Cahir	0.99	25.6	25.5	24.9	25.1	25.4	25.7	26.1	26.6	27.1	27.5
CAR	Belfast - Carnmoney Main	0.99	27.7	27.6	27.5	27.4	27.3	27.2	27.1	27.1	27.1	27
CBG	Carrowbeg	0.99	18	17.9	17.6	17.7	17.9	18.1	18.4	18.7	19.1	19.4
CBR	Castlebar	0.95	43.2	43	42.1	42.5	43	43.4	44.2	45	45.8	46.5
CDY	Corderry	0.1	0.18	0.17	0.17	0.17	0.17	0.18	0.18	0.18	0.19	0.19
CEN	Belfast - Belfast Central Main	0.99	57.3	57.5	57.6	57.9	58.2	58.5	58.8	59.1	59.5	59.8
CF	Cathaleen's Fall	0.95	17.4	17.4	17	17.1	17.3	17.5	17.8	18.2	18.5	18.8
CFM	Castlefarm	0.9	50.8	50.8	50.8	50.8	50.8	50.8	50.8	0	50.8	50.8
CHA	Charleville	0.96	18.9	18.8	18.4	18.6	18.8	19	19.3	19.7	20	20.4
CKG	Corkagh	0.95	33.3	33.3	113	113	113	113	113	113	113	113
CKM	Carrickmines	0.97	248	248	244	246	247	249	252	306	258	261
CLE	Clonee	0.95	-	43.60	69.34	69.34	69.34	69.34	69.34	69.34	69.34	69.34
CLG	Cloghran	0.95	23.8	23.8	23.8	23.8	23.8	23.8	23.8	23.8	23.8	23.8
CLN	Cloon	0.98	30.9	30.8	30.2	30.4	30.8	31.1	31.6	32.2	32.8	33.3
CLW	Carlow	0.97	62	61.8	60.5	61	61.7	62.4	63.5	64.6	65.7	66.8
COL (N)	Coleraine Main	0.98	42.5	42.5	42.4	42.4	42.5	42.6	42.7	42.8	43	43.1
COL (I)	College Park	0.99	22.9	22.9	22.4	22.6	22.8	23.1	23.5	23.9	24.3	24.7
COS	Carickonshannon	0.98	27.7	27.6	27	27.3	27.6	27.9	28.3	28.9	29.4	29.8
COW	Cow Cross	0.95	17.1	17.1	16.7	16.8	17	17.2	17.5	17.8	18.1	18.4
CPS	Coolkeeragh Main	0.96	27.9	28.1	28.2	28.5	28.8	29.1	29.3	29.6	30	30.3
CRA	Crane	0.99	37	36.9	29.2	29.4	29.8	30.1	30.6	31.2	31.7	32.2
CRE	Belfast - Cregagh Main	0.98	77.5	77.6	77.6	64.7	64.9	65.1	65.3	65.6	65.9	66.2
CRG	Creagh Main	1	25.7	25.7	25.6	25.6	25.7	25.7	25.8	25.9	25.9	26
CRO	Coolroe	0.99	11.2	11.2	11	11.1	11.2	11.3	11.5	11.7	11.9	12.1
CVW	Castleview	0.96	24.7	24.6	24.1	24.3	24.5	24.8	25.2	25.7	26.1	26.6

Table C-1 Demand Forecasts at Time of Winter Peak

Bus Code	Bus Name	Power Factor	Demand Forecast (MW)									
			2016	2017	2018	2019	2020	2021	2022	2023	2024	2025
DAL	Dallow	0.97	17.3	17.3	16.9	17	17.2	17.4	17.7	18	18.4	18.7
DDK	Dundalk	0.99	65.6	65.3	64	64.5	65.2	65.9	67.1	68.3	69.5	44.3
DFR	Dunfirth	0.95	7.28	7.25	7.1	7.16	7.24	7.31	7.44	7.58	7.71	7.84
DGN	Dungarvan	0.96	41.6	41.5	40.6	40.9	41.4	41.8	42.6	43.4	44.1	44.8
DLT	Dalton	0.97	23	23	22.5	22.7	22.9	23.1	23.6	24	24.4	24.8
DMY	Dunmanway	0.96	27.6	27.5	26.9	27.1	27.4	27.7	28.2	28.7	29.2	29.7
DON	Belfast - Donegall Main	0.99	107	107	107	108	108	108	109	109	110	110
DOO	Doon	0.97	29.5	29.4	28.8	29	29.3	29.6	30.1	30.7	31.2	31.7
DRU (I)	Drumline	0.96	28.4	28.3	27.7	28	28.3	28.6	29.1	115	30.1	30.6
DRU (N)	Drumnakelly Main	0.98	96.3	98.6	102	104	105	60.6	60.9	61.2	61.6	62
DRY	Drybridge	0.97	81.5	81.3	79.6	80.2	81.1	82	83.4	0	86.4	81.5
DUN	Dungannon Main	0.95	100	101	101	101	102	102	102	103	104	104
EDE	Eden Main	0.98	32.8	32.8	32.7	32.7	32.8	32.8	32.9	32.9	33	33.1
ENN (I)	Ennis	0.95	64.4	64.2	62.8	63.3	64.1	64.7	65.9	139	68.2	69.4
ENN (N)	Enniskillen Main	0.98	58.4	58.5	58.5	58.6	58.8	58.9	59.1	59.3	59.5	59.8
FIN (N)	Belfast - Finaghy Main	0.99	32.9	33	33	33.1	33.2	33.3	33.4	33.6	33.7	33.9
FIN (I)	Finglas	0.98	477	476	467	470	475	479	487	423	502	510
GAL	Galway	0.99	71.3	71	69.6	70.1	70.9	71.6	72.9	83.2	75.5	76.8
GI	Great Island	0.95	13.7	13.7	13.4	13.5	13.6	13.8	14	14.3	14.5	14.8
GIL	Gilra	0.97	11.4	11.4	11.4	11.4	11.4	11.4	11.4	11.4	11.4	11.4
GLE (N)	Belfast - Glengormely Main	0.98	24.6	24.8	24.8	25	25.1	25.3	25.4	25.6	25.8	26
GLE (I)	Glenlara	0.84	23.4	23.3	22.8	23	23.3	23.5	23.9	24.4	24.8	25.2
GRI	Griffinrath	0.95	53.1	53	51.9	52.3	52.9	53.4	54.4	55.3	56.3	57.3
GWE	Gortawee	0.95	34.2	34.1	33.9	34	34.1	34.3	34.5	34.7	35	35.2
IKE	Ikerrin	1	29.6	29.5	28.9	29.1	29.4	29.7	30.3	30.8	31.3	31.9
INC	Inchicore	0.97	422	421	436	439	443	446	453	450	466	472
KBY	Kilbarry	0.99	88.6	88.3	86.5	87.2	89.1	90.1	91.7	93.3	95	96.5
KER	Knockeragh	0.98	35	34.9	34.2	34.5	34.9	35.2	35.8	36.5	37.1	37.8

Table C-1 Demand Forecasts at Time of Winter Peak

Bus Code	Bus Name	Power Factor	Demand Forecast (MW)									
			2016	2017	2018	2019	2020	2021	2022	2023	2024	2025
KIN	Kinnegad	0.97	10.2	10.2	10.2	10.2	10.2	10.2	10.2	10.2	10.2	10.2
KKY	Kilkenny	0.98	64.6	64.3	63	52.7	53.3	53.8	54.8	55.7	56.7	57.7
KNO	Belfast - Knock Main	0.98	50.1	50.1	50.1	42.2	42.3	42.4	42.6	42.7	42.8	43
KTL	Kilteel	0.96	45.6	45.4	44.5	44.9	45.4	45.8	46.6	47.5	48.3	49.1
KTN	Killoteran	0.97	16.6	16.6	16.2	16.3	16.5	16.7	17	17.3	17.6	17.9
KUR	Knockumber	0.91	23.7	23.7	23.7	23.7	23.7	23.7	23.7	23.7	23.7	23.7
LA	Lanesboro	0.97	16	15.9	15.6	15.7	15.9	16.1	16.3	16.6	16.9	17.2
LAR	Larne - Main	0.95	46.8	46.8	46.7	46.8	46.9	47	47.1	47.3	47.4	47.6
LET	Letterkenny	0.9	69.4	64.1	62.8	63.3	64	64.7	65.8	67	68.2	69.3
LIB	Liberty	1	20.1	20	19.6	19.7	20	20.2	20.5	20.9	21.3	21.6
LIM (N)	Limavady Main	0.86	22.7	22.6	22.6	22.6	22.7	22.7	22.7	22.8	22.8	22.9
LIM (I)	Limerick	0.99	78.3	78.1	76.4	77	77.9	78.7	80.1	81.6	83	84.4
LIS (N)	Lisburn Main	0.99	74.9	74.9	74.8	74.9	75.1	75.3	75.5	75.7	76	76.2
LIS (I)	Lisdrum	0.97	29.4	29.3	28.7	28.9	29.2	29.5	30	30.6	31.1	31.6
LMR	Lisaghmore Main	0.98	50.5	50.4	50.3	50.4	50.4	50.5	50.6	50.7	50.9	51
LOG	Loughestown Main	0.98	39.9	40	39.9	40	40.2	40.3	40.5	40.7	40.9	41.1
LSN	Lisheen	0.96	19.5	0	0	0	0	0	0	0	0	0
MAC	Macroom	0.82	17.7	17.6	17.2	17.4	17.6	17.8	18.1	18.4	18.7	19
MAL	Mallow	0.99	21.8	21.8	21.3	21.5	21.7	22	22.3	22.7	23.1	23.5
MCE	Macetown	0.98	31.7	31.6	31	31.2	31.5	31.8	32.3	32.8	33.3	33.8
MID	Midleton	0.96	39.9	39.7	38.9	39.2	39.7	40.1	40.8	41.5	42.3	43
MLN	Mullagharlin	0.96	4.46	4.46	4.46	4.46	4.46	4.46	4.46	4.46	4.46	4.46
MON	Monread	0.99	14.4	14.4	14.1	14.2	14.3	14.5	14.7	15	15.3	15.5
MOY	Moy	0.99	27.1	27	26.4	26.6	26.9	27.2	27.7	28.2	28.7	29.2
MR	Marina	0.98	15.1	15	14.7	14.8	15	15.1	15.4	15.7	16	16.2
MTH	Meath Hill	0.92	51.8	51.7	50.6	51	51.6	52.1	53	54	54.9	55.8
MUL	Mullingar	0.98	47.7	47.5	46.5	46.9	47.4	47.9	48.8	49.6	50.5	51.3
MUN	Mungret	0.87	21.5	21.5	21.5	21.5	21.5	21.5	21.5	21.5	21.5	21.5
NAR	Newtownards Main	0.99	46.7	46.7	46.6	46.7	46.7	46.8	46.9	47	47.2	47.3
NAV	Navan	0.97	60.9	60.7	59.4	59.9	60.6	61.2	62.3	63.4	64.5	65.6
NEN	Nenagh	0.97	54.1	53.9	52.8	53.2	53.8	54.4	55.4	56.3	57.3	58.3

Table C-1 Demand Forecasts at Time of Winter Peak

Bus Code	Bus Name	Power Factor	Demand Forecast (MW)									
			2016	2017	2018	2019	2020	2021	2022	2023	2024	2025
NEW (I)	Newbridge	0.98	28.6	28.5	27.9	28.1	28.4	28.7	29.2	29.7	30.3	30.8
NEW (N)	Newry Main	0.99	81.3	81.3	81.2	81.4	81.6	81.8	82.1	82.4	82.7	83
OLD	Oldcourt	0.96	0.3	0.3	0.3	0.3	0.3	0.3	0.3	0.3	0.3	0.3
OMA	Omagh Main	0.98	60.5	60.5	60.4	60.5	60.6	60.8	60.9	61.1	61.4	61.6
OUG	Oughtragh	0.97	24.7	24.6	24.1	24.3	24.6	24.8	25.2	25.7	26.2	26.6
PB	Poolbeg	0.99	261	260	255	257	260	262	267	272	276	281
PLA	Platin	0.96	12.7	12.7	12.7	12.7	12.7	12.7	12.7	12.7	12.7	12.7
PLS	Portlaoise	0.99	54.3	54.1	53	39.5	40	40.4	41.1	41.9	42.6	43.3
RAT (N)	Rathgael Main	1	61.9	61.9	61.8	61.9	62.1	62.2	62.4	62.6	62.8	63
RAT (I)	Rathkeale	0.78	23.2	23.1	22.6	22.8	23.1	23.3	23.7	24.1	24.6	25
RIC	Richmond	0.97	35.8	35.6	34.9	35.2	35.6	36	36.6	37.2	37.9	38.5
RNW	Rinawade	0.99	9.13	9.13	9.13	9.13	9.13	9.13	9.13	9.13	9.13	9.13
ROS	Rosebank Main	0.96	34.7	34.7	34.6	34.6	34.7	34.7	34.8	34.9	35	35
RSY	Ringaskiddy	0.95	3.81	3.8	3.72	3.75	3.79	3.83	3.9	3.97	4.04	4.11
RYB	Ryebrook	0.96	105	105	105	105	105	105	105	105	105	105
SAL	Salthill	0.99	48.5	48.4	47.4	47.7	48.3	48.8	49.7	50.6	51.4	52.3
SCR	Screeb	0.9	32.1	32	31.3	31.5	31.9	32.2	32.8	33.4	34	34.5
SHE	Shelton Abbey	0.96	2.29	2.29	2.29	2.29	2.29	2.29	2.29	2.29	2.29	2.29
SKL	Shankill	0.97	54.7	54.5	53.3	53.8	54.4	55	55.9	56.9	57.9	58.9
SLI	Sligo	1	55.2	55	53.9	54.3	54.9	55.5	56.5	57.5	58.5	59.5
SNG	Singland	0.99	13.2	13.2	12.9	13	13.2	13.3	13.5	13.8	14	14.3
SOM	Somerset	0.98	18.5	18.4	18.1	18.2	18.4	18.6	18.9	19.3	19.6	19.9
SPR	Springtown Main	0.98	30.3	30.5	30.5	30.6	30.9	31.1	31.3	31.5	31.7	32
STR (N)	Strabane Main	0.98	39.8	39.7	39.7	39.7	39.8	39.8	39.9	40	40.1	40.2
STR (I)	Stratford	0.99	20.8	20.7	20.3	20.4	20.7	20.9	21.3	21.6	22	22.4
TBG	Trabeg	0.95	71.6	71.4	69.9	70.4	71.3	72	73.3	74.6	75.9	77.1
TBK	Tullabrack	0.83	7.92	7.9	7.73	7.8	7.89	7.97	8.11	8.25	8.4	8.54
THU	Thurles	0.96	29.1	29	28.4	28.6	29	29.3	29.8	30.3	30.8	31.4
TIP	Tipperary	0.93	20.3	20.2	19.8	20	20.2	20.4	20.8	21.1	21.5	21.9
TLK	Trillick	0.96	20.4	20.4	19.9	20.1	20.3	20.5	20.9	21.3	21.7	22

Table C-1 Demand Forecasts at Time of Winter Peak

Bus Code	Bus Name	Power Factor	Demand Forecast (MW)									
			2016	2017	2018	2019	2020	2021	2022	2023	2024	2025
TON	Tonroe	0.78	15.6	15.5	15.2	15.3	15.5	15.6	15.9	16.2	16.5	16.8
TRI	Trien	0.96	24.4	24.4	23.9	24	24.3	24.6	25	25.5	25.9	26.3
TRL	Tralee	0.97	55.7	55.5	54.3	54.7	55.4	55.9	56.9	58	59	60
TSB	Thornsberry	0.96	32	31.9	31.2	31.5	31.9	32.2	32.7	33.3	33.9	34.5
WAR	Waringstown Main	0.99	66.8	66.8	66.6	66.7	66.8	66.9	67	67.2	67.4	67.6
WAT	Waterford	0.85	52	51.8	50.7	51.1	50.8	51.3	52.2	53.1	54.1	54.9
WEX	Wexford	0.94	57.5	57.3	56.1	56.5	57.2	57.8	58.8	59.9	60.9	61.9
WHI	Whitegate	0.87	9	9	9	9	9	9	9	9	9	9

Table C-2 Demand Forecasts at Time of Summer Peak

Bus Code	Bus Name	Power Factor	Demand Forecast (MW)									
			2016	2017	2018	2019	2020	2021	2022	2023	2024	2025
AA	Ardnacrusha	0.98	26	26.5	26.1	25.3	25.6	25.8	26.3	26.8	27.3	27.8
AD	Aghada	0.95	1.31	1.34	1.31	1.27	1.29	1.3	1.33	1.35	1.38	1.4
AGH	Aghyoule	0.99	13.3	13.5	13.6	13.8	13.9	14.1	14.3	14.5	14.7	14.9
AGY	Ardnagappary	0.95	0	0	11.8	11.5	11.6	11.7	12	12.2	12.4	12.6
AHA	Ahane	0.99	3.43	3.49	3.44	3.33	3.37	3.41	3.47	3.54	3.6	3.66
AIR	Belfast - Airport Road Main	0.97	-	-	-	-	17.6	17.7	17.7	17.8	17.9	18
ANR	Anner	0.9	14	14	14	14	14	14	14	14	14	14
ANT	Antrim Main	0.98	32.8	32.8	32.8	32.9	33.1	33.2	33.4	33.5	33.7	33.9
ARI	Arigna	0.83	3.52	3.58	3.53	3.42	3.46	3.5	3.56	3.63	3.7	3.76
ARK	Arklow	1	28.6	29.1	28.6	20.9	21.2	21.4	21.8	22.2	22.6	23
ARM	Armagh	0.97	-	-	-	-	-	35.5	35.7	35.8	36	36.2
ATH	Athlone	0.98	54.6	51.7	50.9	49.3	49.9	50.4	51.4	52.4	53.3	54.3
ATY	Athy	0.93	14	14.2	14	13.5	13.7	13.9	14.1	14.4	14.6	14.9
BAL	Baltrasna	0.98	10.8	11	10.8	10.5	10.6	10.7	10.9	11.1	11.3	11.5
BAN (N)	Banbridge Main	0.98	31.4	31.4	31.3	31.4	31.4	31.5	31.5	31.6	31.7	31.8
BAN (I)	Bandon	0.97	35.2	43.8	43.2	41.9	42.4	42.8	43.6	44.3	45.1	45.9
BAR	Barrymore	0.98	20.2	20.5	20.2	19.6	19.8	20	20.4	20.8	21.2	21.5
BDA	Baroda	0.99	5.26	5.26	5.26	5.26	5.26	5.26	5.26	5.26	5.26	5.26
BDN	Ballydine	0.97	14.6	14.7	14.6	14.3	14.4	14.5	14.7	14.8	15	15.2
BEG	Ballybeg	0.99	10.6	10.8	10.6	10.3	10.4	10.5	10.7	10.9	11.1	11.3
BGD	Belgard	0.95	-	-	63.00	63.00	63.00	63.00	63.00	63.00	63.00	63.00
BGT	Ballyrag	0.95	0	0	0	0	19.1	19.3	19.6	20	20.4	20.7
BIN	Binbane	0.88	19.6	20	11.7	11.3	11.5	11.6	11.8	12	12.3	12.5
BK	Bellacorick	0.95	4.41	4.49	4.41	4.27	4.33	4.37	4.46	4.54	4.62	4.7
BKY	Barnakyle	0.95	7.56	7.7	7.57	7.33	7.42	7.5	7.64	7.79	7.93	8.07
BLI	Ballylickey	0.72	12.1	12.3	12.1	11.7	11.9	12	12.2	12.5	12.7	12.9
BLK	Blake	0.98	20.1	20.5	9.8	9.5	9.61	9.72	9.9	10.1	10.3	10.5
BMA	Ballymena Main	0.96	67	67.2	67.2	67.5	67.8	68.1	68.4	68.7	69.1	69.4
BNH	Ballynahinch Main	0.99	47.5	47.5	47.4	47.4	47.5	47.6	47.7	47.8	47.9	48.1
BNM	Belfast - Belfast North Main	0.96	39.3	39.2	42.5	42.8	43.1	43.3	43.6	43.9	44.3	44.6
BOG	Banoge	0.96	4.14	4.21	4.14	16.1	16.3	16.5	16.8	17.1	17.5	17.8
BRA	Bracklon	0.95	0	0	0	10	10.2	10.3	10.5	10.7	10.9	11

Table C-2 Demand Forecasts at Time of Summer Peak

Bus Code	Bus Name	Power Factor	Demand Forecast (MW)									
			2016	2017	2018	2019	2020	2021	2022	2023	2024	2025
BRI	Brinny	0.97	3.95	3.95	3.95	3.95	3.95	3.95	3.95	3.95	3.95	3.95
BRY	Barnahely	0.95	23.8	24.2	23.8	23.1	23.4	23.6	24.1	24.5	25	25.4
BUT	Butlerstown	0.99	25.3	25.7	25.3	24.5	24.8	25.1	25.5	26	26.5	27
CAH	Cahir	0.99	19.7	20.1	19.8	19.1	19.4	19.6	19.9	20.3	20.7	21.1
CAR	Belfast - Carnmoney Main	0.99	21.8	21.7	21.6	21.5	21.4	21.4	21.3	21.3	21.3	21.2
CBG	Carrowbeg	0.99	13.9	14.2	13.9	13.5	13.6	13.8	14.1	14.3	14.6	14.8
CBR	Castlebar	0.95	33.3	33.9	33.4	32.4	32.7	33.1	33.7	34.4	35	35.6
CDY	Corderry	0.1	0.13	0.13	0.13	0.13	0.13	0.13	0.13	0.13	0.14	0.14
CEN	Belfast - Belfast Central Main	0.99	45.1	45.2	45.3	45.5	45.7	45.9	46.2	46.4	46.7	47
CF	Cathaleen's Fall	0.95	13.5	13.7	13.5	13.1	13.2	13.4	13.6	13.9	14.1	14.4
CFM	Castlefarm	0.9	50.8	50.8	50.8	50.8	50.8	50.8	50.8	50.8	50.8	50.8
CHA	Charleville	0.96	14.6	14.8	14.6	14.2	14.3	14.5	14.7	15	15.3	15.6
CKG	Corkagh	0.96	33.3	33.3	33.3	113	113	113	113	113	113	113
CKM	Carrickmines	0.97	212	214	212	208	209	211	213	215	218	220
CLE	Clonee	0.95	-	-	43.60	69.34	69.34	69.34	69.34	69.34	69.34	69.34
CLG	Cloghran	0.95	23.8	23.8	23.8	23.8	23.8	23.8	23.8	23.8	23.8	23.8
CLN	Cloon	0.98	20.1	24.3	23.9	23.2	23.4	23.7	24.1	24.6	25.1	25.5
CLW	Carlow	0.97	47.9	48.8	48	46.5	47	47.5	48.4	49.3	50.3	51.1
COL (N)	Coleraine Main	0.98	33.4	33.4	33.3	33.4	33.4	33.5	33.6	33.7	33.8	33.9
COL (I)	College Park	0.99	17.7	18	17.7	17.2	17.4	17.6	17.9	18.3	18.6	18.9
COS	Carickonshannon	0.98	21.4	21.8	21.4	20.8	21	21.2	21.6	22	22.4	22.8
COW	Cow Cross	0.95	13.2	13.5	8.61	12.8	13	13.1	13.4	13.6	13.9	14.1
CPS	Coolkeeragh Main	0.96	21.9	22.1	22.2	22.4	22.6	22.8	23.1	23.3	23.5	23.8
CRA	Crane	0.99	28.6	29.1	28.6	22.4	22.7	22.9	23.3	23.8	24.2	24.7
CRE	Belfast - Cregagh Main	0.98	60.9	61	61	50.8	51	51.2	51.3	51.6	51.8	52
CRG	Creagh Main	1	20.2	20.2	20.1	20.2	20.2	20.2	20.3	20.3	20.4	20.4
CRO	Coolroe	0.99	8.68	8.84	8.69	8.42	8.53	8.62	8.78	8.95	9.11	9.27
CVW	Castleview	0.97	19.1	19.4	19.1	18.5	18.7	18.9	19.3	19.6	20	20.3
DAL	Dallow	0.97	13.4	13.6	13.4	13	13.1	13.3	13.5	13.8	14	14.3
DDK	Dundalk	0.99	50.6	51.5	50.7	49.1	49.7	50.3	51.2	52.2	53.1	54.1
DFR	Dunfirth	0.95	5.62	5.72	5.63	5.45	5.52	5.58	5.68	5.79	5.9	6
DGN	Dungarvan	0.96	32.1	32.7	32.2	31.2	31.6	31.9	32.5	33.1	33.7	34.3

Table C-2 Demand Forecasts at Time of Summer Peak

Bus Code	Bus Name	Power Factor	Demand Forecast (MW)									
			2016	2017	2018	2019	2020	2021	2022	2023	2024	2025
DLT	Dalton	0.97	17.8	18.1	17.8	17.2	17.5	17.6	18	18.3	18.7	19
DMY	Dunmanway	0.96	24.9	21.7	21.3	20.6	20.9	21.1	21.5	21.9	22.3	22.7
DON	Belfast - Donegall Main	0.99	84.1	84.3	84.3	84.5	84.8	85.1	85.5	85.9	86.3	86.7
DOO	Doon	0.97	22.8	23.2	22.8	22.1	22.3	22.6	23	23.4	23.9	24.3
DRU (I)	Drumline	0.96	22	22.4	22	21.3	21.6	21.8	22.2	22.6	23	23.4
DRU (N)	Drumnakelly Main	0.98	75.7	77.5	79.8	82	82.4	47.6	47.9	48.1	48.4	48.7
DRY	Drybridge	0.97	63	64.1	63	61.1	61.8	62.5	63.7	64.9	66.1	67.2
DUN	Dungannon Main	0.95	79	79.2	79.2	79.4	79.8	80.2	80.5	81	81.4	81.9
EDE	Eden Main	0.98	25.8	25.8	25.7	25.7	25.8	25.8	25.8	25.9	26	26
ENN (I)	Ennis	0.95	49.7	50.6	49.8	48.2	48.8	49.4	50.3	51.2	52.2	53.1
ENN (N)	Enniskillen Main	0.98	45.9	46	46	46	46.2	46.3	46.5	46.6	46.8	47
FIN (N)	Belfast - Finaghy Main	0.99	25.9	25.9	25.9	26	26.1	26.2	26.3	26.4	26.5	26.6
FIN (I)	Finglas	0.98	380	386	381	370	374	378	384	390	396	402
GAL	Galway	0.99	55	56	55.1	53.4	54	54.6	55.6	56.7	57.8	58.8
GI	Great Island	0.95	10.6	10.8	10.6	10.3	10.4	10.5	10.7	10.9	11.1	11.3
GIL	Gilra	0.97	11.4	11.4	11.4	11.4	11.4	11.4	11.4	11.4	11.4	11.4
GLE (N)	Belfast - Glengormely Main	0.98	19.3	19.5	19.5	19.6	19.8	19.9	20	20.1	20.3	20.5
GLE (I)	Glenlara	0.84	18.1	18.4	18.1	17.5	17.8	17.9	18.3	18.6	19	19.3
GRI	Griffinrath	0.95	41.1	41.8	41.1	39.8	40.3	40.7	41.5	42.3	43.1	43.8
GWE	Gortawee	0.95	31.2	31.4	31.2	30.9	31	31.1	31.3	31.5	31.7	31.9
IKE	Ikerrin	1	22.8	23.3	22.9	22.2	22.4	22.7	23.1	23.5	24	24.4
INC	Inchicore	0.96	340	345	340	354	358	361	366	371	376	381
KBY	Kilbarry	0.99	68.4	69.7	68.5	66.4	67.2	68.7	70	71.3	72.6	73.9
KER	Knockeraugh	0.98	27.1	27.5	27.1	26.3	26.6	26.9	27.4	27.9	28.4	28.9
KIN	Kinnegad	0.97	10.2	10.2	10.2	10.2	10.2	10.2	10.2	10.2	10.2	10.2
KKY	Kilkenny	0.98	49.9	50.7	49.9	48.4	40.6	41	41.8	42.6	43.4	44.1
KNO	Belfast - Knock Main	0.98	39.4	39.4	39.4	33.2	33.3	33.4	33.4	33.6	33.7	33.8
KTL	Kilteel	0.96	35.2	35.8	35.3	34.2	34.6	34.9	35.6	36.3	36.9	37.6
KTN	Killoteran	0.97	12.8	13.1	12.8	12.4	12.6	12.7	13	13.2	13.5	13.7
KUR	Knockumber	0.91	23.7	23.7	23.7	23.7	23.7	23.7	23.7	23.7	23.7	23.7
LA	Lanesboro	0.97	11	11.1	11.3	10.7	10.9	11.1	11.2	11.4	11.4	11.1
LAR	Larne - Main	0.95	36.8	36.8	36.7	36.8	36.8	36.9	37	37.1	37.3	37.4

Table C-2 Demand Forecasts at Time of Summer Peak

Bus Code	Bus Name	Power Factor	Demand Forecast (MW)									
			2016	2017	2018	2019	2020	2021	2022	2023	2024	2025
LET	Letterkenny	0.9	53.6	54.5	49.7	48.2	48.8	49.3	50.2	51.2	52.1	53
LIB	Liberty	1	15.5	15.8	15.5	15	15.2	15.4	15.7	16	16.3	16.5
LIM (N)	Limavady Main	0.86	17.8	17.8	17.8	17.8	17.8	17.8	17.9	17.9	18	18
LIM (I)	Limerick	0.99	60.5	61.6	60.6	58.7	59.4	60	61.1	62.3	63.5	64.6
LIS (N)	Lisburn Main	0.99	58.8	58.9	58.8	58.9	59	59.2	59.3	59.5	59.7	59.9
LIS (I)	Lisdrum	0.97	22.7	23.1	22.7	22	22.3	22.5	22.9	23.4	23.8	24.2
LMR	Lisaghmore Main	0.98	39.7	39.6	39.6	39.6	39.7	39.7	39.8	39.9	40	40.1
LOG	Loughestown Main	0.98	31.3	31.4	31.4	31.5	31.6	31.7	31.8	32	32.1	32.3
LSN	Lisheen	0.96	19.5	19.5	0	0	0	0	0	0	0	0
MAC	Macroon	0.82	17.9	13.9	13.7	13.2	13.4	13.5	13.8	14.1	14.3	14.6
MAL	Mallow	0.99	16.9	17.2	16.9	16.4	16.6	16.7	17.1	17.4	17.7	18
MCE	Macetown	0.98	25.5	25.9	25.5	24.9	25.1	25.3	25.7	26.1	26.5	26.9
MID	Midleton	0.96	30.8	31.3	30.8	29.9	30.2	30.6	31.1	31.7	32.3	32.9
MLN	Mullagharlin	0.96	4.46	4.46	4.46	4.46	4.46	4.46	4.46	4.46	4.46	4.46
MON	Monread	0.99	11.1	11.3	11.1	10.8	10.9	11	11.2	11.5	11.7	11.9
MOY	Moy	0.99	20.9	21.3	20.9	20.3	20.5	20.7	21.1	21.5	21.9	22.3
MR	Marina	0.98	11.6	11.8	11.6	11.3	11.4	11.5	11.8	12	12.2	12.4
MTH	Meath Hill	0.92	40	40.8	40.1	38.8	39.3	39.7	40.5	41.2	42	42.7
MUL	Mullingar	0.98	36.8	37.5	36.9	35.7	36.1	36.5	37.2	37.9	38.6	39.3
MUN	Mungret	0.87	21.5	21.5	21.5	21.5	21.5	21.5	21.5	21.5	21.5	21.5
NAR	Newtownards Main	0.99	36.7	36.7	36.6	36.7	36.7	36.8	36.9	37	37.1	37.2
NAV	Navan	0.97	47	47.9	47.1	45.6	46.2	46.7	47.5	48.4	49.3	50.2
NEN	Nenagh	0.97	41.8	42.5	41.8	40.5	41	41.5	42.2	43	43.8	44.6
NEW (I)	Newbridge	0.98	22.1	22.5	22.1	21.4	21.7	21.9	22.3	22.7	23.1	23.5
NEW (N)	Newry Main	0.99	63.9	63.9	63.8	64	64.2	64.3	64.5	64.7	65	65.3
OLD	Oldcourt	0.96	0.3	0.3	0.3	0.3	0.3	0.3	0.3	0.3	0.3	0.3
OMA	Omagh Main	0.98	47.5	47.5	47.5	47.5	47.6	47.8	47.9	48.1	48.2	48.4
OUG	Oughtragh	0.97	19.1	19.4	19.1	18.5	18.7	18.9	19.3	19.6	20	20.3
PB	Poolbeg	0.99	201	205	202	195	198	200	204	208	211	215
PLA	Platin	0.96	12.7	12.7	12.7	12.7	12.7	12.7	12.7	12.7	12.7	12.7
PLS	Portlaoise	0.99	41.9	42.7	42	40.7	30.5	30.8	31.4	32	32.6	33.1
RAT (N)	Rathgael Main	1	48.7	48.7	48.6	48.7	48.8	48.9	49	49.2	49.3	49.5

Table C-2 Demand Forecasts at Time of Summer Peak

Bus Code	Bus Name	Power Factor	Demand Forecast (MW)									
			2016	2017	2018	2019	2020	2021	2022	2023	2024	2025
RAT (I)	Rathkeale	0.78	17.9	18.2	17.9	17.4	17.6	17.8	18.1	18.4	18.8	19.1
RIC	Richmond	0.97	27.6	28.1	27.7	26.8	27.1	27.4	27.9	28.5	29	29.5
RNW	Rinawade	0.99	9.13	9.13	9.13	9.13	9.13	9.13	9.13	9.13	9.13	9.13
ROS	Rosebank Main	0.96	27.3	27.2	27.2	27.2	27.3	27.3	27.3	27.4	27.5	27.5
RSY	Ringaskiddy	0.95	2.94	3	2.95	2.86	2.89	2.92	2.98	3.03	3.09	3.14
RYB	Ryebrook	0.96	105	105	105	105	105	105	105	105	105	105
SAL	Salthill	0.99	37.5	38.2	37.5	36.4	36.8	37.2	37.9	38.6	39.3	40
SCR	Screeb	0.9	24.8	25.2	24.8	24	24.3	24.6	25	25.5	26	26.4
SHE	Shelton Abbey	0.96	2.29	2.29	2.29	2.29	2.29	2.29	2.29	2.29	2.29	2.29
SKL	Shankill	0.97	42.2	43	42.3	40.9	41.4	41.9	42.7	43.5	44.3	45.1
SLI	Sligo	1	42.6	43.4	42.7	41.4	41.9	42.3	43.1	43.9	44.7	45.5
SNG	Singland	0.99	10.2	10.4	10.2	9.91	10	10.1	10.3	10.5	10.7	10.9
SOM	Somerset	0.98	14.3	14.5	14.3	13.9	14	14.2	14.4	14.7	15	15.3
SPR	Springtown Main	0.98	23.8	23.9	23.9	24.1	24.3	24.4	24.6	24.8	25	25.2
STR (N)	Strabane Main	0.98	31.3	31.2	31.2	31.2	31.3	31.3	31.4	31.4	31.5	31.6
STR (I)	Stratford	0.99	16	16.3	16.1	15.6	15.8	15.9	16.2	16.5	16.8	17.1
TBG	Trabeg	0.95	55.3	56.3	55.4	53.6	54.3	54.9	55.9	57	58	59
TBK	Tullabrack	0.83	6.13	6.24	6.14	5.94	6.02	6.08	6.19	6.31	6.43	6.54
THU	Thurles	0.96	22.5	22.9	22.5	21.8	22.1	22.3	22.7	23.2	23.6	24
TIP	Tipperary	0.93	15.7	16	15.7	15.2	15.4	15.6	15.9	16.2	16.5	16.7
TLK	Trillick	0.96	15.8	16.1	15.8	15.3	15.5	15.7	15.9	16.2	16.5	16.8
TON	Tonroe	0.78	12	12.2	12	11.7	11.8	11.9	12.1	12.4	12.6	12.8
TRI	Trien	0.96	18.9	19.2	18.9	18.3	18.5	18.7	19.1	19.4	19.8	20.1
TRL	Tralee	0.97	43	43.7	43	41.7	42.2	42.7	43.4	44.3	45.1	45.9
TSB	Thornsberry	0.96	24.7	25.2	24.8	24	24.3	24.5	25	25.5	25.9	26.4
WAR	Waringstown Main	0.99	52.5	52.5	52.4	52.4	52.5	52.6	52.7	52.8	53	53.1
WAT	Waterford	0.85	40.1	40.9	40.2	38.9	39.4	39.1	39.8	40.6	41.3	42
WEX	Wexford	0.94	44.4	45.2	44.5	43.1	43.6	44.1	44.9	45.7	46.6	47.4
WHI	Whitegate	0.87	9	9	9	9	9	9	9	9	9	9

Table C-3 Demand Forecasts at Time of Summer Valley

Bus Code	Bus Name	Power Factor	Demand Forecast (MW)									
			2016	2017	2018	2019	2020	2021	2022	2023	2024	2025
AA	Ardnacrusha	0.96	11.3	11.6	10.9	9.63	9.81	9.97	10.3	10.5	10.8	11.1
AD	Aghada	0.95	0.42	0.43	0.4	0.36	0.36	0.37	0.38	0.39	0.4	0.41
AGH	Aghyoule	0.99	4.96	5.01	5.06	5.13	5.2	5.27	5.33	5.41	5.48	5.56
AGY	Ardnagappary	0.95	0	0	3.41	3.03	3.09	3.14	3.22	3.32	3.41	3.49
AHA	Ahane	0.98	0.76	0.77	0.72	0.64	0.65	0.67	0.68	0.7	0.72	0.74
AIR	Belfast - Airport Road Main	0.97	-	-	-	-	6.56	6.58	6.61	6.63	6.66	6.69
ANR	Anner	0.9	14	14	14	14	14	14	14	14	14	14
ANT	Antrim Main	0.98	12.2	12.2	12.2	12.3	12.3	12.4	12.4	12.5	12.6	12.6
ARI	Arigna	0.44	1.07	1.1	1.02	0.91	0.92	0.94	0.97	0.99	1.02	1.05
ARK	Arklow	0.96	7.93	8.12	7.59	4.94	5.03	5.11	5.26	5.4	5.55	5.69
ARM	Armagh	0.97	-	-	-	-	-	13.2	13.3	13.4	13.4	13.5
ATH	Athlone	1	17.3	16.5	15.4	13.7	13.9	14.2	14.6	15	15.4	15.8
ATY	Athy	0.84	4.18	4.28	4	3.55	3.61	3.67	3.77	3.88	3.99	4.09
BAL	Baltrasna	0.98	3.47	3.55	3.32	2.95	3	3.05	3.14	3.23	3.31	3.4
BAN (N)	Banbridge Main	0.98	11.7	11.7	11.7	11.7	11.7	11.7	11.8	11.8	11.8	11.9
BAN (I)	Bandon	0.98	11.9	14.6	13.8	12.4	12.6	12.8	13.1	13.4	13.7	14
BAR	Barrymore	0.95	6.42	6.58	6.15	5.45	5.56	5.65	5.81	5.97	6.13	6.29
BDA	Baroda	0.99	5.26	5.26	5.26	5.26	5.26	5.26	5.26	5.26	5.26	5.26
BDN	Ballydine	0.96	8.25	8.3	8.15	7.9	7.94	7.97	8.03	8.09	8.14	8.2
BEG	Ballybeg	1	3.19	3.27	3.06	2.71	2.76	2.81	2.89	2.97	3.05	3.13
BGD	Belgard	0.95	-	-	63.00	63.00	63.00	63.00	63.00	63.00	63.00	63.00
BGT	Ballyrag	0.95	0	0	0	0	5.07	5.15	5.29	5.44	5.59	5.74
BIN	Binbane	0.79	5.94	6.09	3.39	3.01	3.07	3.12	3.2	3.29	3.39	3.47
BK	Bellacorick	0.95	1.13	1.15	1.08	0.96	0.98	0.99	1.02	1.05	1.08	1.1
BKY	Barnakyle	0.95	2.28	2.34	2.18	1.94	1.97	2	2.06	2.12	2.18	2.23
BLI	Ballylickey	0.48	3.03	3.11	2.9	2.58	2.62	2.67	2.74	2.82	2.9	2.97
BLK	Blake	0.81	7.25	7.42	3.95	3.5	3.57	3.63	3.73	3.83	3.94	4.04
BMA	Ballymena Main	0.96	25	25	25.1	25.2	25.2	25.4	25.5	25.6	25.7	25.9
BNH	Ballynahinch Main	0.99	17.7	17.7	17.7	17.7	17.7	17.7	17.8	17.8	17.9	17.9
BNM	Belfast - Belfast North Main	0.96	14.6	14.6	15.8	15.9	16.1	16.2	16.3	16.4	16.5	16.6
BOG	Banoge	0.97	1.96	2.01	1.88	4.87	4.96	5.04	5.18	5.33	5.48	5.61

Table C-3 Demand Forecasts at Time of Summer Valley

Bus Code	Bus Name	Power Factor	Demand Forecast (MW)									
			2016	2017	2018	2019	2020	2021	2022	2023	2024	2025
BRA	Bracklon	0.95	0	0	0	2.65	2.7	2.74	2.82	2.9	2.98	3.06
BRI	Brinny	0.97	3.95	3.95	3.95	3.95	3.95	3.95	3.95	3.95	3.95	3.95
BRY	Barnahely	0.93	13	13.3	12.4	11	11.2	11.4	11.7	12.1	12.4	12.7
BUT	Butlerstown	1	8.57	8.78	8.2	7.28	7.41	7.53	7.75	7.96	8.18	8.39
CAH	Cahir	1	6.5	6.66	6.22	5.52	5.62	5.72	5.88	6.04	6.21	6.37
CAR	Belfast - Carnmoney Main	0.99	8.13	8.09	8.04	8.01	7.99	7.97	7.95	7.93	7.92	7.91
CBG	Carrowbeg	1	6.45	6.61	6.17	5.48	5.58	5.67	5.83	6	6.16	6.32
CBR	Castlebar	0.92	6.99	7.16	6.69	5.94	6.05	6.15	6.32	6.5	6.68	6.85
CDY	Corderry	0	0	0	0	0	0	0	0	0	0	0
CEN	Belfast - Belfast Central Main	0.99	16.8	16.8	16.9	17	17	17.1	17.2	17.3	17.4	17.5
CF	Cathleen's Fall	1	3.66	3.75	3.5	3.11	3.16	3.22	3.31	3.4	3.49	3.58
CFM	Castlefarm	0.9	50.8	50.8	50.8	50.8	50.8	50.8	50.8	50.8	50.8	50.8
CHA	Charleville	0.98	4.67	4.78	4.47	3.97	4.04	4.11	4.22	4.34	4.46	4.57
CKG	Corkagh	0.96	33.3	33.3	33.3	113	113	113	113	113	113	113
CKM	Carrickmines	0.96	128	129	126	122	123	123	124	125	126	127
CLE	Clonee	0.95	-	-	43.60	69.34	69.34	69.34	69.34	69.34	69.34	69.34
CLG	Cloghran	0.95	23.8	23.8	23.8	23.8	23.8	23.8	23.8	23.8	23.8	23.8
CLN	Cloon	0.95	5.28	6.57	6.14	5.45	5.55	5.64	5.8	5.96	6.13	6.28
CLW	Carlow	1	14.3	14.6	13.6	12.1	12.3	12.5	12.9	13.3	13.6	14
COL (N)	Coleraine Main	0.98	12.4	12.4	12.4	12.4	12.5	12.5	12.5	12.6	12.6	12.6
COL (I)	College Park	0.97	11.5	11.8	11	9.77	9.95	10.1	10.4	10.7	11	11.3
COS	Carickonshannon	0.99	6.69	6.85	6.4	5.68	5.78	5.88	6.04	6.21	6.39	6.55
COW	Cow Cross	0.95	6.58	6.74	4.97	5.59	5.69	5.78	5.95	6.11	6.29	6.44
CPS	Coolkeeragh Main	0.96	8.16	8.24	8.27	8.34	8.43	8.51	8.59	8.68	8.77	8.87
CRA	Crane	1	8.73	8.94	8.35	6	6.12	6.21	6.39	6.57	6.76	6.93
CRE	Belfast - Cregagh Main	0.98	22.7	22.7	22.7	18.9	19	19.1	19.1	19.2	19.3	19.4
CRG	Creagh Main	1	7.52	7.51	7.5	7.51	7.53	7.54	7.55	7.57	7.6	7.62
CRO	Coolroe	0.95	4.34	4.45	4.16	3.69	3.76	3.82	3.93	4.04	4.15	4.25
CVW	Castlevew	0.98	8.79	9	8.41	7.46	7.6	7.73	7.94	8.17	8.39	8.61
DAL	Dallow	0.99	3.8	3.89	3.63	3.22	3.28	3.34	3.43	3.53	3.63	3.72

Table C-3 Demand Forecasts at Time of Summer Valley

Bus Code	Bus Name	Power Factor	Demand Forecast (MW)									
			2016	2017	2018	2019	2020	2021	2022	2023	2024	2025
DDK	Dundalk	1	12.4	12.7	11.8	10.5	10.7	10.9	11.2	11.5	11.8	12.1
DFR	Dunfirth	0.95	2.16	2.21	2.07	1.83	1.87	1.9	1.95	2.01	2.06	2.12
DGN	Dungarvan	0.97	8.59	8.79	8.21	7.29	7.42	7.55	7.76	7.98	8.2	8.41
DLT	Dalton	0.96	6.25	6.4	5.98	5.31	5.4	5.49	5.65	5.81	5.97	6.12
DMY	Dunmanway	0.54	6.72	5.77	5.39	4.78	4.87	4.95	5.09	5.24	5.38	5.52
DON	Belfast - Donegall Main	0.99	31.4	31.4	31.4	31.5	31.6	31.7	31.9	32	32.2	32.3
DOO	Doon	1	6.51	6.67	6.23	5.53	5.63	5.72	5.88	6.05	6.22	6.38
DRU (I)	Drumline	0.95	8.11	8.31	7.76	6.89	7.02	7.13	7.33	7.54	7.75	7.94
DRU (N)	Drumnakelly Main	0.98	28.2	28.9	29.7	30.6	30.7	17.8	17.8	17.9	18	18.2
DRY	Drybridge	1	19.4	19.8	18.5	16.5	16.8	17	17.5	18	18.5	19
DUN	Dungannon Main	0.95	29.4	29.5	29.5	29.6	29.7	29.9	30	30.2	30.3	30.5
EDE	Eden Main	0.98	9.61	9.6	9.58	9.59	9.6	9.61	9.63	9.65	9.67	9.7
ENN (I)	Ennis	1	14.1	14.5	13.5	12	12.2	12.4	12.8	13.1	13.5	13.8
ENN (N)	Enniskillen Main	0.98	17.1	17.1	17.1	17.2	17.2	17.3	17.3	17.4	17.4	17.5
FIN (N)	Belfast - Finaghy Main	0.99	9.64	9.66	9.66	9.68	9.72	9.75	9.79	9.83	9.88	9.92
FIN (I)	Finglas	0.97	159	162	155	143	145	146	149	152	155	157
GAL	Galway	1	20.8	21.3	19.9	17.7	18	18.3	18.8	19.3	19.9	20.4
GI	Great Island	0.95	3.77	3.86	3.61	3.2	3.26	3.31	3.41	3.5	3.6	3.69
GIL	Gilra	0.97	11.4	11.4	11.4	11.4	11.4	11.4	11.4	11.4	11.4	11.4
GLE (N)	Belfast - Glengormely Main	0.98	7.21	7.25	7.26	7.3	7.36	7.4	7.46	7.51	7.57	7.62
GLE (I)	Glenlara	0.41	4.31	4.41	4.12	3.66	3.72	3.79	3.89	4	4.11	4.22
GRI	Griffinrath	0.95	12.2	12.5	11.7	10.4	10.6	10.7	11	11.4	11.7	12
GWE	Gortawee	0.95	26.4	26.6	26.2	25.6	25.7	25.8	25.9	26.1	26.2	26.3
IKE	Ikerrin	1	7.21	7.38	6.9	6.12	6.24	6.34	6.52	6.7	6.89	7.06
INC	Inchicore	0.97	160	163	156	168	170	171	173	176	179	181
KBY	Kilbarry	0.99	14.7	15	14	12.5	12.7	13.1	13.5	13.8	14.2	14.6
KER	Knockeragh	0.99	10.2	10.5	9.77	8.67	8.83	8.98	9.23	9.49	9.75	10
KIN	Kinnegad	0.97	10.2	10.2	10.2	10.2	10.2	10.2	10.2	10.2	10.2	10.2
KKY	Kilkenny	1	11.9	12.2	11.4	10.1	8.07	8.2	8.43	8.67	8.91	9.14
KNO	Belfast - Knock Main	0.98	14.7	14.7	14.7	12.4	12.4	12.4	12.5	12.5	12.6	12.6

Table C-3 Demand Forecasts at Time of Summer Valley

Bus Code	Bus Name	Power Factor	Demand Forecast (MW)									
			2016	2017	2018	2019	2020	2021	2022	2023	2024	2025
KTL	Kilteel	0.98	11.3	11.5	10.8	9.55	9.73	9.89	10.2	10.5	10.7	11
KTN	Killoteran	0.97	4.44	4.54	4.25	3.77	3.84	3.9	4.01	4.12	4.24	4.35
KUR	Knockumber	0.91	23.7	23.7	23.7	23.7	23.7	23.7	23.7	23.7	23.7	23.7
LA	Lanesboro	0.98	3.19	3.27	3.06	2.71	2.76	2.81	2.89	2.97	3.05	3.13
LAR	Larne - Main	0.95	13.7	13.7	13.7	13.7	13.7	13.8	13.8	13.8	13.9	13.9
LET	Letterkenny	0.98	14.3	14.6	12.5	11.1	11.3	11.5	11.8	12.2	12.5	12.8
LIB	Liberty	0.97	5.52	5.65	5.28	4.69	4.78	4.85	4.99	5.13	5.27	5.41
LIM (N)	Limavady Main	0.86	6.64	6.63	6.62	6.63	6.63	6.64	6.65	6.67	6.69	6.7
LIM (I)	Limerick	1	20.7	21.2	19.8	17.6	17.9	18.2	18.7	19.2	19.7	20.2
LIS (N)	Lisburn Main	0.99	21.9	21.9	21.9	21.9	22	22	22.1	22.2	22.3	22.3
LIS (I)	Lisdrum	0.98	7.04	7.2	6.73	5.97	6.08	6.18	6.36	6.54	6.72	6.89
LMR	Lisaghmore Main	0.98	14.8	14.8	14.7	14.8	14.8	14.8	14.8	14.9	14.9	14.9
LOG	Loughestown Main	0.98	11.7	11.7	11.7	11.7	11.8	11.8	11.9	11.9	12	12
LSN	Lisheen	0.96	19.5	19.5	0	0	0	0	0	0	0	0
MAC	Macroom	0.49	8.69	7.57	7.07	6.27	6.39	6.5	6.68	6.87	7.06	7.24
MAL	Mallow	0.99	5.53	5.66	5.29	4.69	4.78	4.86	5	5.14	5.28	5.41
MCE	Macetown	0.99	12.2	12.4	11.9	11	11.2	11.3	11.5	11.7	11.8	12
MID	Midleton	0.97	14.4	14.8	13.8	12.2	12.5	12.7	13	13.4	13.8	14.1
MLN	Mullagharlin	0.96	4.46	4.46	4.46	4.46	4.46	4.46	4.46	4.46	4.46	4.46
MON	Monread	1	3	3.08	2.87	2.55	2.6	2.64	2.72	2.79	2.87	2.94
MOY	Moy	1	6.43	6.59	6.15	5.46	5.56	5.65	5.81	5.98	6.14	6.3
MR	Marina	0.95	4.15	4.25	3.97	3.52	3.59	3.65	3.75	3.85	3.96	4.06
MTH	Meath Hill	0.97	11	11.3	10.5	9.33	9.5	9.66	9.93	10.2	10.5	10.8
MUL	Mullingar	0.97	9.59	9.82	9.17	8.14	8.29	8.43	8.66	8.91	9.16	9.39
MUN	Mungret	0.87	21.5	21.5	21.5	21.5	21.5	21.5	21.5	21.5	21.5	21.5
NAR	Newtownards Main	0.99	13.7	13.7	13.7	13.7	13.7	13.7	13.7	13.8	13.8	13.9
NAV	Navan	0.77	12.5	12.8	11.9	10.6	10.8	11	11.3	11.6	11.9	12.2
NEN	Nenagh	0.97	11.7	12	11.2	9.92	10.1	10.3	10.6	10.9	11.2	11.4
NEW (I)	Newbridge	0.99	5.92	6.06	5.67	5.03	5.12	5.21	5.35	5.5	5.66	5.8
NEW (N)	Newry Main	0.99	23.8	23.8	23.8	23.8	23.9	24	24	24.1	24.2	24.3

Table C-3 Demand Forecasts at Time of Summer Valley

Bus Code	Bus Name	Power Factor	Demand Forecast (MW)									
			2016	2017	2018	2019	2020	2021	2022	2023	2024	2025
OLD	Oldcourt	0.96	0.3	0.3	0.3	0.3	0.3	0.3	0.3	0.3	0.3	0.3
OMA	Omagh Main	0.98	17.7	17.7	17.7	17.7	17.8	17.8	17.8	17.9	18	18.1
OUG	Oughtragh	0.82	7.59	7.77	7.26	6.44	6.56	6.67	6.86	7.05	7.25	7.43
PB	Poolbeg	0.99	81	83	77	69	70	71	73	75	77	79
PLA	Platin	0.96	12.7	12.7	12.7	12.7	12.7	12.7	12.7	12.7	12.7	12.7
PLS	Portlaoise	0.95	12.8	13.1	12.2	10.8	8.18	8.31	8.55	8.8	9.04	9.26
RAT (N)	Rathgael Main	1	18.1	18.1	18.1	18.1	18.2	18.2	18.3	18.3	18.4	18.5
RAT (I)	Rathkeale	0.99	5.79	5.93	5.54	4.92	5.01	5.09	5.23	5.38	5.53	5.67
RIC	Richmond	1	8.03	8.23	7.68	6.82	6.95	7.06	7.26	7.46	7.67	7.87
RNW	Rinawade	0.99	9.13	9.13	9.13	9.13	9.13	9.13	9.13	9.13	9.13	9.13
ROS	Rosebank Main	0.96	10.2	10.2	10.1	10.1	10.2	10.2	10.2	10.2	10.2	10.3
RSY	Ringaskiddy	0.95	0.65	0.67	0.63	0.56	0.57	0.58	0.59	0.61	0.63	0.64
RYB	Ryebrook	0.96	105	105	105	105	105	105	105	105	105	105
SAL	Salthill	0.95	13.5	13.8	12.9	11.4	11.6	11.8	12.2	12.5	12.9	13.2
SCR	Screeb	0.84	9.14	9.36	8.74	7.76	7.9	8.03	8.26	8.49	8.73	8.95
SHE	Shelton Abbey	0.96	2.29	2.29	2.29	2.29	2.29	2.29	2.29	2.29	2.29	2.29
SKL	Shankill	0.98	10.9	11.1	10.4	9.21	9.38	9.54	9.8	10.1	10.4	10.6
SLI	Sligo	1	13.3	13.6	12.7	11.3	11.5	11.7	12	12.3	12.7	13
SNG	Singland	1	3.46	3.55	3.31	2.94	2.99	3.04	3.13	3.22	3.31	3.39
SOM	Somerset	0.99	4.94	5.06	4.73	4.19	4.27	4.34	4.46	4.59	4.72	4.84
SPR	Springtown Main	0.98	8.87	8.92	8.92	8.97	9.04	9.1	9.16	9.22	9.3	9.37
STR (N)	Strabane Main	0.98	11.7	11.7	11.6	11.6	11.7	11.7	11.7	11.7	11.7	11.8
STR (I)	Stratford	1	4.01	4.11	3.84	3.4	3.47	3.52	3.62	3.73	3.83	3.93
TBG	Trabeg	0.95	22.8	23.4	21.8	19.4	19.7	20.1	20.6	21.2	21.8	22.3
TBK	Tullabrack	0.85	2.52	2.58	2.41	2.14	2.18	2.21	2.27	2.34	2.4	2.47
THU	Thurles	0.99	7.15	7.32	6.84	6.07	6.18	6.29	6.46	6.65	6.83	7
TIP	Tipperary	0.84	5.06	5.19	4.84	4.3	4.38	4.45	4.58	4.71	4.84	4.96
TLK	Trillick	0.97	3.97	4.06	3.79	3.37	3.43	3.49	3.58	3.68	3.79	3.88
TON	Tonroe	0.95	4.74	4.86	4.54	4.03	4.1	4.17	4.29	4.41	4.53	4.65
TRI	Trien	0.95	11.5	11.8	11	9.8	9.98	10.1	10.4	10.7	11	11.3

Table C-3 Demand Forecasts at Time of Summer Valley

Bus Code	Bus Name	Power Factor	Demand Forecast (MW)									
			2016	2017	2018	2019	2020	2021	2022	2023	2024	2025
TRL	Tralee	0.95	11.2	11.5	10.7	9.52	9.7	9.85	10.1	10.4	10.7	11
TSB	Thornsberry	0.86	7.05	7.22	6.74	5.99	6.1	6.2	6.37	6.55	6.73	6.9
WAR	Waringstown Main	0.99	19.6	19.6	19.5	19.5	19.6	19.6	19.6	19.7	19.7	19.8
WAT	Waterford	0.92	19.4	19.8	18.5	16.4	16.7	16.8	17.3	17.8	18.3	18.7
WEX	Wexford	0.99	14.6	15	14	12.4	12.6	12.8	13.2	13.6	14	14.3
WHI	Whitegate	0.87	9	9	9	9	9	9	9	9	9	9

Table C-4 Demand Forecasts at Time of Autumn Peak – Northern Ireland only

Bus Code	Bus Name	Power Factor	Demand Forecast (MW)									
			2016	2017	2018	2019	2020	2021	2022	2023	2024	2025
AGH	Aghyoule	0.99	14.7	14.89	15.02	15.22	15.42	15.62	15.82	16.03	16.03	16.49
AIR	Belfast - Airport Road Main	0.974	-	-	-	19.41	19.47	19.53	19.6	19.68	19.68	19.85
ANT	Antrim Main	0.98	36.22	36.3	36.3	36.42	36.58	36.74	36.9	37.09	37.09	37.5
ARM	Armagh	0.974	-	-	-	-	-	39.28	39.43	39.62	39.62	40.06
BAN (N)	Banbridge Main	0.98	34.71	34.69	34.64	34.67	34.74	34.79	34.86	34.95	34.95	35.15
BMA	Ballymena Main	0.96	74.1	74.32	74.33	74.61	74.93	75.25	75.57	75.92	75.92	76.75
BNH	Ballynahinch Main	0.99	52.51	52.48	52.4	52.44	52.53	52.61	52.7	52.83	52.83	53.12
BNM	Belfast - Belfast North Main	0.96	43.41	43.39	46.98	47.3	47.61	47.92	48.22	48.55	48.55	49.3
CAR	Belfast - Carnmoney Main	0.99	24.11	23.99	23.85	23.77	23.71	23.64	23.58	23.54	23.54	23.47
CEN	Belfast - Belfast Central Main	0.99	49.82	49.97	50.07	50.29	50.55	50.8	51.06	51.34	51.34	51.98
COL (N)	Coleraine Main	0.98	36.9	36.89	36.84	36.89	36.97	37.03	37.11	37.22	37.22	37.44
CPS	Coolkeeragh Main	0.96	24.2	24.45	24.52	24.76	25.01	25.25	25.49	25.75	25.75	26.32
CRE	Belfast - Cregagh Main	0.98	67.37	67.47	67.45	56.18	56.38	56.56	56.78	56.99	56.99	57.53
CRG	Creagh Main	1	22.3	22.29	22.26	22.28	22.33	22.36	22.41	22.47	22.47	22.6
DON	Belfast - Donegall Main	0.99	93.01	93.16	93.16	93.43	93.8	94.13	94.51	94.93	94.93	95.88
DRU (N)	Drumnakelly Main	0.98	83.71	85.67	88.22	90.68	91.13	52.67	52.92	53.21	53.21	53.88
DUN	Dungannon Main	0.95	87.3	87.54	87.52	87.82	88.24	88.63	89.04	89.5	89.5	90.52
EDE	Eden Main	0.98	28.5	28.48	28.43	28.44	28.48	28.52	28.56	28.62	28.62	28.77
ENN (N)	Enniskillen Main	0.98	50.77	50.82	50.81	50.9	51.05	51.19	51.34	51.53	51.53	51.95
FIN (N)	Belfast - Finaghy Main	0.99	28.6	28.66	28.65	28.73	28.84	28.94	29.04	29.17	29.17	29.44
GLE (N)	Belfast - Glengormely Main	0.98	21.38	21.52	21.55	21.68	21.83	21.97	22.11	22.27	22.27	22.63
KNO	Belfast - Knock Main	0.98	43.56	43.57	43.51	36.69	36.79	36.88	36.98	37.09	37.09	37.37
LAR	Larne - Main	0.95	40.63	40.63	40.58	40.63	40.73	40.83	40.93	41.06	41.06	41.34
LIM (N)	Limavady Main	0.86	19.69	19.68	19.64	19.65	19.69	19.71	19.75	19.78	19.78	19.89
LIS (N)	Lisburn Main	0.99	65.05	65.07	64.99	65.09	65.26	65.4	65.57	65.77	65.77	66.24

Table C-4 Demand Forecasts at Time of Autumn Peak – Northern Ireland only

Bus Code	Bus Name	Power Factor	Demand Forecast (MW)									
			2016	2017	2018	2019	2020	2021	2022	2023	2024	2025
LMR	Lisaghmore Main	0.98	43.84	43.8	43.74	43.76	43.84	43.89	43.97	44.07	44.07	44.31
LOG	Lougestown Main	0.98	34.65	34.72	34.69	34.79	34.93	35.06	35.2	35.35	35.35	35.71
NAR	Newtownards Main	0.99	40.58	40.56	40.5	40.54	40.62	40.69	40.78	40.88	40.88	41.13
NEW (N)	Newry Main	0.99	70.61	70.66	70.59	70.72	70.93	71.12	71.33	71.58	71.58	72.15
OMA	Omagh Main	0.98	52.53	52.56	52.47	52.56	52.69	52.81	52.94	53.13	53.13	53.51
RAT (N)	Rathgael Main	1	53.79	53.8	53.73	53.8	53.94	54.05	54.19	54.35	54.35	54.74
ROS	Rosebank Main	0.96	30.14	30.12	30.06	30.08	30.13	30.17	30.22	30.29	30.29	30.45
SPR	Springtown Main	0.98	26.32	26.47	26.47	26.62	26.81	26.99	27.17	27.37	27.37	27.81
STR (N)	Strabane Main	0.98	34.56	34.52	34.48	34.5	34.57	34.61	34.69	34.78	34.78	34.95
WAR	Waringstown Main	0.99	58.04	58	57.91	57.95	58.05	58.13	58.24	58.38	58.38	58.7

All-Island Ten Year

Transmission Forecast
Statement **2016**

Appendix D



Appendix D: Generation Capacity and Dispatch Details

Table D-1 lists existing and committed future transmission connected generation, their connection details and the Registered Capacity¹ of each unit. Table D-2 details capacities of these units for the ten years of this TYTFS. All generation capacity figures in Table D-1 and Table D-2 are expressed in exported terms. Exported terms are given by the generation unit output less the unit's own auxiliary load. The units are grouped in these tables on a geographical basis. Generation capacity figures are rounded to the nearest MW.

Table D-3 lists the existing and committed future wind generation. The wind generation included in this table is wind generation that feeds into each 110 kV transmission station, from the distribution system. The results for each year up to 2025 are included. Table D-3 is based on the wind farms that currently have signed connection agreements with the DSO. The connection agreements are based on the best available knowledge as at the beginning of July 2016.

Table D-4 lists the existing and committed dispatchable distribution connected conventional generation in Ireland. Their respective MW capacity over the period of the statement is included.

Table D-5 lists the existing and committed distribution connected renewable generation in Northern Ireland, excluding wind generation. Their respective MW capacity over the period of the statement is included.

Table D-6 lists the existing and proposed generating plant contract details in Northern Ireland.

Please see EirGrid's website² for an update on the Gate 3 generators which have committed to connecting to the transmission system. This commitment is given by executing connection agreements with EirGrid.

Where dual fuel capability exists, the fuel type highlighted in red is utilised to meet peak demand.

1. The Registered Capacity of future units will not be known until the unit enters the Single Electricity Market. Therefore, for future units the Maximum Export Capacity of the unit appears in Table D-1.

2. <http://www.eirgridgroup.com/customer-and-industry/general-customer-information/gate-3/>

D.1 Generation Capacity Details

Table D-1 MEC and Connection Information of Existing and Committed Transmission-Connected Generation

Area	Generation Station	Unit ID	Connected At		Fuel Type	Maximum Export Capacity (MEC)
Dublin	Dublin Bay Power	DB1	Irishstown	220 kV	Gas/DO	415
	Huntstown	HNC	Huntstown A	220 kV	Gas/DO	352
	Huntstown	HN2	Huntstown B	220 kV	Gas/DO	412
	North Wall	NW5	North Wall	220 kV	Gas/DO	109
	Poolbeg	PBC	Shellybanks	220 kV	Gas/DO	460
	Liffey Hydro	LI1	Pollaphuca	110 kV	Distillate	15
	Liffey Hydro	LI2	Pollaphuca	110 kV	Hydro	15
	Liffey Hydro	LI4	Pollaphuca	110 kV	Hydro	4
	Turlough Hill	TH1	Turlough Hill	220 kV	Hydro	73
	Turlough Hill	TH2	Turlough Hill	220 kV	Hydro	73
	Turlough Hill	TP	Turlough Hill	220 kV	Hydro	73
	Turlough Hill	TH4	Turlough Hill	220 kV	Hydro	73
Dublin Area Total						2074
Midlands	Cuilleen OCGT	-	Athlone	110 kV	Gas/DO	98
	Dooray	-	Killinaparson	110 kV	Wind	55
	Edenderry Power	ED1	Cushaling	110 kV	Peat	122
	Edenderry PCP	ED3	Cushaling	110 kV	Distillate	58
	Edenderry PCP	ED5	Cushaling	110 kV	Distillate	58
	Kill Hill	-	Kill Hill	110 kV	Wind	59
	Lisheen	-	Lisheen	110 kV	Wind	59
	Mount Lucas	-	Mount Lucas	110 kV	Wind	79
	Rhode PCP	RP1	Derryiron	110 kV	Distillate	52
	Rhode PCP	RP2	Derryiron	110 kV	Distillate	52
	Suir OCGT	SUR	Cahir	110 kV	Gas/DO	98
	West Offaly Power	WO4	Shannonbridge	110 kV	Peat	141
Midlands Area Total						931

Table D-1 MEC and Connection Information of Existing and Committed Transmission-Connected Generation

Area	Generation Station	Unit ID	Connected At		Fuel Type	Maximum Export Capacity (MEC)
Mid-West	Ardnacrusha	AA1	Ardnacrusha	110 kV	Hydro	22
	Ardnacrusha	AA2	Ardnacrusha	110 kV	Hydro	22
	Ardnacrusha	AA3	Ardnacrusha	110 kV	Hydro	21
	Ardnacrusha	AA4	Ardnacrusha	110 kV	Hydro	21
	Aughinish	SK3	Sealrock	110 kV	Gas/DO	65
	Aughinish	SK4	Sealrock	110 kV	Gas/DO	65
	Booltiagh	-	Booltiagh	110 kV	Wind	20
	Booltiagh Ext	-	Booltiagh	110 kV	Wind	12
	Cahernagh Mid Merit	-	Cahernagh Mid Merit	110 kV	OCGT	101
	Derrybrien	-	Derrybrien	110 kV	Wind	60
	Keelderry (1)	-	Knockavanna	110 kV	Wind	27
	Moneypoint	MP1	Moneypoint	380 kV	Coal	288
	Moneypoint	MP2	Moneypoint	380 kV	Coal/HFO	288
	Moneypoint	MP3	Moneypoint	380 kV	Coal	288
	Moneypoint	-	Moneypoint	110 kV	Wind	22
	Tarbert	TB1	Tarbert	110 kV	HFO	54
	Tarbert	TB2	Tarbert	110 kV	HFO	54
	Tarbert	TB3	Tarbert	220 kV	HFO	241
	Tarbert	TB4	Tarbert	220 kV	HFO	241
	Tynagh	TY	Tynagh	220 kV	Gas	404
Mid West Area Total						2343
North-East	Bindoo	-	Ratrussan	110 kV	Wind	48
	Castletownmoor	-	Castletownmoor	110 kV	Wind	120
	Mountain Lodge	-	Ratrussan	110 kV	Wind	31
	Oriel	-	Oriel	110kV	Wind	210
North-East Area Total						409

Table D-1 MEC and Connection Information of Existing and Committed Transmission-Connected Generation

Area	Generation Station	Unit ID	Connected At		Fuel Type	Maximum Export Capacity (MEC)
Northern Ireland	Ballylumford B10	B10	Ballylumford	110 kV	Gas/Gasoil	97
	Ballylumford B31	B31	Ballylumford	275 kV	Gas/Gasoil	245
	Ballylumford B32	B32	Ballylumford	275 kV	Gas/Gasoil	245
	Ballylumford GT7	BGT1	Ballylumford	110 kV	Gasoil	58
	Ballylumford GT8	BGT2	Ballylumford	110 kV	Gasoil	58
	Ballylumford ST4 &5	B4 & 5	Ballylumford	275 kV	Gas/HFO	250
	Brockaghboy	-	Brockaghboy	110 kV	Wind	66
	CAES	-	Ballylumford	275 kV	Comp. Air	330
	Coolkeeragh CCGT	C30	Coolkeeragh	275 & 110 kV	Gas/Gasoil	402
	Coolkeeragh GT8	CGT8	Coolkeeragh	275 kV	Gasoil	53
	Kilroot GT1	KGT1	Kilroot	275 kV	Gasoil	29
	Kilroot GT2	KGT2	Kilroot	275 kV	Gasoil	29
	Kilroot GT3	KGT3	Kilroot	275 kV	Gasoil	42
	Kilroot GT4	KGT4	Kilroot	275 kV	Gasoil	42
	Kilroot ST1	K1	Kilroot	275 kV	Coal/Oil	257
	Kilroot ST2	K2	Kilroot	275 kV	Coal/Oil	257
	Slieve Kirk	SLK	Killymallaght	110 kV	Wind	83
	Torr Head, Fair Head	-	Kells	110 kV	Tidal	210
Northern Ireland Area Total						2691

Table D-1 MEC and Connection Information of Existing and Committed Transmission-Connected Generation

Area	Generation Station	Unit ID	Connected At		Fuel Type	Maximum Export Capacity (MEC)
North-West	Cronacarkfree	-	Cronacarkfree	110 kV	Wind	105
	Erne	ER3	Cathaleen's Fall	110 kV	Hydro	23
	Erne	ER4	Cathaleen's Fall	110 kV	Hydro	23
	Erne	ER1	Cliff	110 kV	Hydro	10
	Erne	ER2	Cliff	110 kV	Hydro	10
	Golagh	-	Golagh	110 kV	Wind	15
	Garvagh	-	Garvagh	110 kV	Wind	26
	Garvagh	-	Garvagh	110 kV	Wind	22
	Kingsmountain	-	Cunghill	110 kV	Wind	35
	Lough Ree Power	LR4	Lanesboro	110 kV	Peat	94
	Meentycat	-	Meentycat	110 kV	Wind	85
	Mulreavy	-	Mulreavy	110 kV	Wind	82
	Mulreavy Ext.	-	Mulreavy	110 kV	Wind	13
	Oweninney (1)	-	Bellacorick	400 kV	Wind	89
	Oweninney (2)	-	Bellacorick	400 kV	Wind	83
	Oweninney (5)	-	Bellacorick	400 kV	Wind	199
	Seecon	-	Ugool	110 kV	Wind	105
	Sliabh Bawn	-	Sliabh Bawn	110 kV	Wind	58
Ugool	-	Ugool	110 kV	Wind	64	
North-West Area Total						1141
South-East	Ballywater	-	Ballywater	110 kV	Wind	42
	Castledockrill	-	Castledockrill	110 kV	Wind	41
	Great Island	GI4	Great Island	220 kV	Gas	431
	Nore Power	NO1	Nore	110 kV	Gas/DO	98
South-East Area Total						612

Table D-1 MEC and Connection Information of Existing and Committed Transmission-Connected Generation

Area	Generation Station	Unit ID	Connected At		Fuel Type	Maximum Export Capacity (MEC)
South-West	Aghada	AD1	Aghada	220 kV	Gas	258
	Aghada	AT1	Aghada	220 kV	Gas/DO	90
	Aghada	AT2	Aghada	220 kV	Gas/DO	90
	Aghada	AT4	Aghada	220 kV	Gas/DO	90
	Aghada CCGT	AD2	Longpoint	220 kV	Gas	431
	Athea	-	Athea	110 kV	Wind	99
	Barnadivane	-	Barnadivane	110 kV	Wind	60
	Boggeragh	-	Boggeragh	110 kV	Wind	57
	Boggeragh (2)	-	Boggeragh	110 kV	Wind	48
	Clahane	-	Clahane	110 kV	Wind	38
	Clahane (2)	-	Clahane	110 kV	Wind	14
	Cloghboola	-	Cloghboola	110 kV	Wind	46
	Cloghboola (2) ext	-	Cloghboola	110 kV	Wind	10
	Coomacheo	-	Garrow	110 kV	Wind	41
	Coomacheo ext	-	Garrow	110 kV	Wind	18
	Coomagearlahy	-	Coomagearlahy	110 kV	Wind	43
	Coomagearlahy ext	-	Coomagearlahy	110 kV	Wind	39
	Coomataggart	-	Coomataggart	110kV	Wind	114
	Cordal	-	Cordal	110kV	Wind	101
	Dromada	-	Dromada	110 kV	Wind	29
	Dromada (1a)	-	Dromada	110 kV	Wind	18
	Glanlee	-	Glanlee	110 kV	Wind	30
	Glanlee (2)	-	Glanlee	110 kV	Wind	6
	Kilavoy	-	Boggeragh	110kV	Wind	18
	Kilgarvan (1)	-	Coomataggart	110kV	Wind	62
	Lee Hydro	LE1	Inniscarra	110 kV	Hydro	15
	Lee Hydro	LE2	Inniscarra	110 kV	Hydro	4
	Lee Hydro	LE3	Carrigadrohid	110 kV	Hydro	8
	Marina	MRT	Marina	110 kV	Gas/DO	85
	Whitegen CCGT	WG	Glanagow	220 kV	Gas/DO	445
	Woodhouse	-	Woodhouse	110 kV	Wind	20
	South-West Area Total					

Table D-2 Forecast MEC of Existing and Committed Transmission-Connected Generation

Area	Generation Station	Unit ID	Maximum Export Capacity (MEC)									
			2016	2017	2018	2019	2020	2021	2022	2023	2024	2025
Dublin	Dublin Bay Power	DB1	415	415	415	415	415	415	415	415	415	415
	Huntstown	HNC	352	352	352	352	352	352	352	352	352	352
	Huntstown	HN2	412	412	412	412	412	412	412	412	412	412
	North Wall	NW 5	109	109	109	109	109	109	109	109	109	109
	Poolbeg	PBC	460	460	460	460	460	460	460	460	460	460
	Liffey Hydro	LI1	15	15	15	15	15	15	15	15	15	15
	Liffey Hydro	LI2	15	15	15	15	15	15	15	15	15	15
	Liffey Hydro	LI4	4	4	4	4	4	4	4	4	4	4
	Turlough Hill	TH1	73	73	73	73	73	73	73	73	73	73
	Turlough Hill	TH2	73	73	73	73	73	73	73	73	73	73
	Turlough Hill	TP	73	73	73	73	73	73	73	73	73	73
	Turlough Hill	TH4	73	73	73	73	73	73	73	73	73	73
Dublin Area Total			207 4	207 4	207 4	207 4	207 4	207 4	207 4	207 4	207 4	207 4
Midlands	Culleen OCGT	-	-	-	-	-	98	98	98	98	98	98
	Dooray	-	-	-	-	-	55	55	55	55	55	55
	Edenderry Power	ED1	122	122	122	122	122	122	122	122	122	122
	Edenderry PCP	ED3	58	58	58	58	58	58	58	58	58	58
	Edenderry PCP	ED5	58	58	58	58	58	58	58	58	58	58
	Kill Hill	-	36	36	36	36	59	59	59	59	59	59
	Lisheen	-	59	59	59	59	59	59	59	59	59	59
	Mount Lucas	-	79	79	79	79	79	79	79	79	79	79
	Rhode PCP	RP1	52	52	52	52	52	52	52	52	52	52
	Rhode PCP	RP2	52	52	52	52	52	52	52	52	52	52
	Suir OCGT	SUR	-	-	-	-	98	98	98	98	98	98
West Offaly Power	WO 4	141	141	141	141	141	141	141	141	141	141	
Midlands Area Total			657	657	657	657	931	931	931	931	931	931

Table D-2 Forecast MEC of Existing and Committed Transmission-Connected Generation

Area	Generation Station	Unit ID	Maximum Export Capacity (MEC)									
			2016	2017	2018	2019	2020	2021	2022	2023	2024	2025
Mid-West	Ardnacrusha	AA1	22	22	22	22	22	22	22	22	22	22
	Ardnacrusha	AA2	22	22	22	22	22	22	22	22	22	22
	Ardnacrusha	AA3	21	21	21	21	21	21	21	21	21	21
	Ardnacrusha	AA4	21	21	21	21	21	21	21	21	21	21
	Aughinish	SK3	65	65	65	65	65	65	65	65	65	65
	Aughinish	SK4	65	65	65	65	65	65	65	65	65	65
	Booltiagh	-	20	20	20	20	20	20	20	20	20	20
	Booltiagh Ext	-	12	12	12	12	12	12	12	12	12	12
	Cahernagh Mid Merit	-	-	-	-	-	101	101	101	101	101	101
	Derrybrien	-	60	60	60	60	60	60	60	60	60	60
	Keelderry (1)	-	-	27	27	27	27	27	27	27	27	27
	Moneypoint	MP1	288	288	288	288	288	288	288	288	288	288
	Moneypoint	MP2	288	288	288	288	288	288	288	288	288	288
	Moneypoint	MP3	288	288	288	288	288	288	288	288	288	288
	Moneypoint	-	-	22	22	22	22	22	22	22	22	22
	Tarbert	TB1	54	54	54	54	54	54	54	-	-	-
	Tarbert	TB2	54	54	54	54	54	54	54	-	-	-
	Tarbert	TB3	241	241	241	241	241	241	241	-	-	-
Tarbert	TB4	241	241	241	241	241	241	241	-	-	-	
Tynagh	TY	404	404	404	404	404	404	404	404	404	404	
Mid-West Area Total			216 6	221 5	221 5	221 5	231 6	231 6	231 6	172 6	172 6	172 6
North-East	Bindoo	-	48	48	48	48	48	48	48	48	48	48
	Castletown-moor	-	-	120	120	120	120	120	120	120	120	120
	Mountain Lodge	-	31	31	31	31	31	31	31	31	31	31
	Oriel	-	-	-	-	-	210	210	210	210	210	210
North-East Area Total			79	199	199	199	409	409	409	409	409	409

Table D-2 Forecast MEC of Existing and Committed Transmission-Connected Generation

Area	Generation Station	Unit ID	Maximum Export Capacity (MEC)									
			2016	2017	2018	2019	2020	2021	2022	2023	2024	2025
Northern Ireland	Ballylumford B10	B10	97	97	97	97	97	97	97	97	97	97
	Ballylumford B31	B31	245	245	245	245	245	245	245	245	245	245
	Ballylumford B32	B32	245	245	245	245	245	245	245	245	245	245
	Ballylumford GT7	BGT	58	58	58	58	58	58	58	58	58	58
	Ballylumford GT8	BGT 2	58	58	58	58	58	58	58	58	58	58
	Ballylumford ST4 & 5	B4 & 5	250	250	250	-	-	-	-	-	-	-
	Brockaghboy	-	-	66	66	66	66	66	66	66	66	66
	CAES	-	-	-	330	330	330	330	330	330	330	330
	Coolkeeragh CCGT	C30	402	402	402	402	402	402	402	402	402	402
	Coolkeeragh GT8	CGT 8	53	53	53	53	53	53	53	53	53	53
	Kilroot GT1	KGT 1	29	29	29	29	29	29	29	29	29	29
	Kilroot GT2	KGT 2	29	29	29	29	29	29	29	29	29	29
	Kilroot GT3	KGT 3	42	42	42	42	42	42	42	42	42	42
	Kilroot GT4	KGT4	42	42	42	42	42	42	42	42	42	42
	Kilroot ST1	K1	257	257	257	257	257	257	257	257	-	-
	Kilroot ST2	K2	257	257	257	257	257	257	257	257	-	-
	Slieve Kirk	SLK	74	83	83	83	83	83	83	83	83	83
Torr Head Fair Head	-	-	-	10	10	210	210	210	210	210	210	
Northern Ireland Area Total			2138	2213	2491	2241	2441	2441	2441	2441	1927	1927

Table D-2 Forecast MEC of Existing and Committed Transmission-Connected Generation

Area	Generation Station	Unit ID	Maximum Export Capacity (MEC)										
			2016	2017	2018	2019	2020	2021	2022	2023	2024	2025	
North-West	Cronacarkfree	-	-	-	-	-	-	-	105	105	105	105	105
	Erne	ER3	23	23	23	23	23	23	23	23	23	23	23
	Erne	ER4	23	23	23	23	23	23	23	23	23	23	23
	Erne	ER1	10	10	10	10	10	10	10	10	10	10	10
	Erne	ER2	10	10	10	10	10	10	10	10	10	10	10
	Golagh	-	15	15	15	15	15	15	15	15	15	15	15
	Garvagh	-	26	26	26	26	26	26	26	26	26	26	26
	Garvagh	-	22	22	22	22	22	22	22	22	22	22	22
	Kingsmountain	-	35	35	35	35	35	35	35	35	35	35	35
	Lough Ree Power	LR4	94	94	94	94	94	94	94	94	94	94	94
	Meentycat	-	85	85	85	85	85	85	85	85	85	85	85
	Mulreavy	-	82	82	82	82	82	82	82	82	82	82	82
	Mulreavy Ext.	-	13	13	13	13	13	13	13	13	13	13	13
	Oweninney (1)	-	-	-	89	89	89	89	89	89	89	89	89
	Oweninney (2)	-	-	-	83	83	83	83	83	83	83	83	83
	Oweninney (5)	-	-	-	-	-	199	199	199	199	199	199	199
	Seecon	-	105	105	105	105	105	105	105	105	105	105	105
	Sliabh Bawn	-	58	58	58	58	58	58	58	58	58	58	58
Ugool	-	64	64	64	64	64	64	64	64	64	64	64	
North-West Area Total			665	665	837	837	1036	1141	1141	1141	1141	1141	

Table D-2 Forecast MEC of Existing and Committed Transmission-Connected Generation

Area	Generation Station	Unit ID	Maximum Export Capacity (MEC)									
			2016	2017	2018	2019	2020	2021	2022	2023	2024	2025
South-East	Ballywater	-	42	42	42	42	42	42	42	42	42	42
	Castledockrill	-	41	41	41	41	41	41	41	41	41	41
	Great Island	GI4	431	431	431	431	431	431	431	431	431	431
	Nore Power	NO1	-	-	-	-	98	98	98	98	98	98
South-East Area Total			514	514	514	514	612	612	612	612	612	612
South-West	Aghada	AD1	258	258	258	258	258	258	258	258	258	258
	Aghada	AT1	90	90	90	90	90	90	90	90	90	90
	Aghada	AT2	90	90	90	90	90	90	90	90	90	90
	Aghada	AT4	90	90	90	90	90	90	90	90	90	90
	Aghada CCGT	AD2	431	431	431	431	431	431	431	431	431	431
	Athea	-	54	54	54	55	99	99	99	99	99	99
	Barndivane	-	-	60	60	60	60	60	60	60	60	60
	Boggeragh	-	57	57	57	57	57	57	57	57	57	57
	Boggeragh (2)	-	48	48	48	48	48	48	48	48	48	48
	Clahane	-	38	38	38	38	38	38	38	38	38	38
	Clahane (2)	-	14	14	14	14	14	14	14	14	14	14
	Cloghboola	-	46	46	46	46	46	46	46	46	46	46
	Cloghboola (2) est	-	-	10	10	10	10	10	10	10	10	10
	Coomacheo	-	41	41	41	41	41	41	41	41	41	41
	Coomacheo ext	-	18	18	18	18	18	18	18	18	18	18
	Coomagearlahy	-	43	43	43	43	43	43	43	43	43	43
	Coomagearlahy ext	-	39	39	39	39	39	39	39	39	39	39
	Coomataggart	-	-	114	114	114	114	114	114	114	114	114
	Cordal	-	-	101	101	101	101	101	101	101	101	101
	Dromada	-	29	29	29	29	29	29	29	29	29	29
Dromada (1a)	-	-	-	-	18	18	18	18	18	18	18	
Glanlee	-	30	30	30	30	30	30	30	30	30	30	
Glanlee (2)	-	-	-	-	6	6	6	6	6	6	6	

Table D-2 Forecast MEC of Existing and Committed Transmission-Connected Generation

Area	Generation Station	Unit ID	Maximum Export Capacity (MEC)									
			2016	2017	2018	2019	2020	2021	2022	2023	2024	2025
South-West	Lee Hydro	LE1	15	15	15	15	15	15	15	15	15	15
	Lee Hydro	LE2	4	4	4	4	4	4	4	4	4	4
	Lee Hydro	LE3	8	8	8	8	8	8	8	8	8	8
	Marina	MRT	85	85	85	85	85	85	85	85	85	85
	Whitegen CCGT	WG	445	445	445	445	445	445	445	445	445	445
	Woodhouse	-	20	20	20	20	20	20	20	20	20	20
South-West Area Total			1993	2278	2278	2303	2347	2347	2347	2347	2347	2347

Table D-3 Forecast MEC of Existing and Committed Distribution-Connected Wind Farm Capacity

Area	110 kV Station	Maximum Export Capacity (MEC)									
		2016	2017	2018	2019	2020	2021	2022	2023	2024	2025
Dublin	Glasmore	0.8	0.8	0.8	0.8	0.8	0.8	0.8	0.8	0.8	0.8
Dublin Area Total		0.8	0.8	0.8	0.8	0.8	0.8	0.8	0.8	0.8	0.8
Midlands	Barrymore	39.9	39.9	39.9	39.9	39.9	39.9	39.9	39.9	39.9	39.9
	Cauteen	111.4	176.6	176.6	196.6	196.6	196.6	196.6	196.6	196.6	196.6
	Cureeny	-	-	140.5	140.5	140.5	140.5	140.5	140.5	140.5	140.5
	Dallow	6.8	21	21	21	21	21	21	21	21	21
	Doon	-	-	-	-	-	25	25	25	25	25
	Dungarvan	4.6	38.6	38.6	38.6	40.3	40.3	40.3	40.3	40.3	40.3
	Ikerrin	36	36	36	36	36	36	36	36	36	36
	Lisheen	39.6	39.6	39.6	39.6	39.6	39.6	39.6	39.6	39.6	39.6
	Nenagh	14	14	14	14	14	14	14	14	14	14
	Portlaoise	9.2	9.2	9.2	9.2	9.2	9.2	9.2	9.2	9.2	9.2
	Thurles	13.8	41.8	41.8	41.8	41.8	41.8	41.8	41.8	41.8	41.8
Tipperary	1.6	1.6	1.6	1.6	1.6	1.6	1.6	1.6	1.6	1.6	
Midlands Area Total		276.9	418.3	558.8	578.8	580.5	605.5	605.5	605.5	605.5	605.5
Mid-West	Ardnacrusha	8.1	8.1	8.1	8.1	8.1	8.1	8.1	8.1	8.1	8.1
	Booltiagh	-	78.6	78.6	83.6	89.6	103	103	103	103	103
	Ennis	-	26.9	26.9	26.9	26.9	26.9	26.9	26.9	26.9	26.9
	Tullabrack	31	31	31	31	31	31	31	31	31	31
Mid-West Area Total		39.1	144.6	144.6	149.6	155.6	169	169	169	169	169
North-East	Drybridge	6.5	6.5	6.5	6.5	7	7	7	7	7	7
	Dundalk	0.5	0.5	0.5	0.5	15.5	15.5	15.5	15.5	15.5	15.5
	Lisdrum	-	33.1	33.1	33.1	49.2	49.2	49.2	49.2	49.2	49.2
	Meath Hill	22.5	48.1	48.1	48.1	50.1	70.7	70.7	70.7	70.7	70.7
	Navan	-	-	4	4	9	9	9	9	9	9
	Shankill	3	3	3	3	25	25	25	25	25	25
North-East Area Total		32.5	91.2	95.2	95.2	155.8	176.4	176.4	176.4	176.4	176.4

Table D-3 Forecast MEC of Existing and Committed Distribution-Connected Wind Farm Capacity

Area	110 kV Station	Maximum Export Capacity (MEC)									
		2016	2017	2018	2019	2020	2021	2022	2023	2024	2025
Northern Ireland	Aghyoule	82.5	82.5	82.5	82.5	82.5	82.5	82.5	82.5	82.5	82.5
	Antrim	4.9	9.9	9.9	9.9	11.6	11.6	11.6	11.6	11.6	11.6
	Ballymena (Rural)	11	55.2	55.2	55.2	60.2	60.2	60.2	60.2	60.2	60.2
	Cam	-	-	-	-	-	-	-	-	90	90
	Carnmoney	13.8	13.8	13.8	13.8	13.8	13.8	13.8	13.8	13.8	13.8
	Coleraine	108	108	108	108	108	108	108	108	108	108
	Coolkeeragh	12	12	12	12	12	12	12	12	12	12
	Curragahmulkin	-	-	88.6	103.6	103.6	103.6	103.6	103.6	103.6	103.6
	Drumnakelly	-	-	4.6	4.6	4.6	4.6	4.6	4.6	4.6	4.6
	Dungannon	17.5	17.5	17.5	17.5	17.5	17.5	17.5	17.5	17.5	17.5
	Eden	2.5	2.5	2.5	2.5	2.5	2.5	2.5	2.5	2.5	2.5
	Enniskillen	31.9	31.9	34.4	34.4	34.4	34.4	34.4	34.4	34.4	34.4
	Garvagh	-	-	-	50.1	50.1	50.1	90	90	90	90
	Gort	-	57.7	70.2	70.2	70.2	70.2	70.2	70.2	70.2	70.2
	Kells	-	-	-	-	90	90	90	90	90	90
	Killymallaght	38.7	38.7	38.7	38.7	38.7	38.7	38.7	38.7	38.7	38.7
	Larne	15	15	15	15	15	15	15	15	15	15
	Limavady	37.7	37.7	37.7	37.7	37.7	37.7	37.7	37.7	37.7	37.7
	Lisaghmore	17.5	17.5	17.5	17.5	17.5	17.5	17.5	17.5	17.5	17.5
	Loguestown	12	12	12	12	12	12	12	12	12	12
	Magherakeel	123.1	123.1	123.1	123.1	123.1	123.1	123.1	123.1	123.1	123.1
	Newry	3.8	3.8	15.3	15.3	15.3	15.3	15.3	15.3	15.3	15.3
	Newtownstewart	-	-	-	-	-	-	-	90	90	90
Omagh	125.7	125.7	125.7	125.7	125.7	125.7	125.7	125.7	125.7	125.7	
Rasharkin	36.8	58	58	58	58	58	58	58	58	58	
Springtown	-	-	-	45	45	45	45	45	45	45	
Strabane	27.4	27.4	27.4	27.4	27.4	27.4	27.4	27.4	27.4	27.4	
Tremoge	49.5	77	77	77	77	77	77	77	77	77	
Northern Ireland Area Total		771.3	926.9	1046.6	1156.7	1253.4	1253.4	1293.3	1383.3	1473.3	1473.3

Table D-3 Forecast MEC of Existing and Committed Distribution-Connected Wind Farm Capacity

Area	110 kV Station	Maximum Export Capacity (MEC)									
		2016	2017	2018	2019	2020	2021	2022	2023	2024	2025
North-West	Ardnagappary	-	13.1	13.1	13.1	13.1	13.1	13.1	13.1	13.1	13.1
	Arigna	15.6	15.6	15.6	15.6	15.6	15.6	15.6	15.6	15.6	15.6
	Bellacorick	9	9	59.7	59.7	75.8	85	85	85	85	85
	Binbane	40.3	76.7	76.7	76.7	81.6	85.8	85.8	85.8	85.8	85.8
	CarrickonShannon	-	-	-	-	4.3	4.3	4.3	4.3	4.3	4.3
	Castlebar	36.2	36.2	36.2	42.3	47.5	47.5	47.5	47.5	47.5	47.5
	CathleenFalls	29.4	29.4	29.4	29.4	29.4	29.4	29.4	29.4	29.4	29.4
	Cloon	4.3	4.3	4.3	4.3	4.3	4.3	4.3	4.3	4.3	4.3
	Corderry	39.5	39.5	39.5	41.1	76.8	76.8	76.8	76.8	76.8	76.8
	Dalton	43.2	43.2	43.2	43.2	43.2	43.2	43.2	43.2	43.2	43.2
	Doolick	-	73.8	73.8	73.8	73.8	73.8	73.8	73.8	73.8	73.8
	Garvagh	-	34	34	34	34	34	34	34	34	34
	Glenree	34.2	34.2	34.2	36.8	49.3	77.3	77.3	77.3	77.3	77.3
	Gortawee	3	3	3	3	3	3	3	3	3	3
	Knockalough	-	33.6	33.6	33.6	33.6	33.6	33.6	33.6	33.6	33.6
	Lanesboro	4.6	4.6	4.6	4.6	4.6	4.6	4.6	4.6	4.6	4.6
	Letterkenny	40.9	51.7	51.7	51.7	68.2	88.2	88.2	88.2	88.2	88.2
	Moy	6	6	6	6	6	6	6	6	6	6
	Mulreavy	38.5	38.5	38.5	38.5	38.5	38.5	38.5	38.5	38.5	38.5
	Salthill	46.1	46.1	46.1	46.1	46.1	46.1	46.1	46.1	46.1	46.1
	Screeb	-	3	3	3	30	30	30	30	30	30
	Sligo	13.7	13.7	13.7	13.7	13.7	13.7	13.7	13.7	13.7	13.7
	Somerset	7.7	7.7	7.7	7.7	19.5	19.5	19.5	19.5	19.5	19.5
SorneHill	56.8	56.8	56.8	56.8	63.4	63.4	63.4	63.4	63.4	63.4	
Tawnaghmore	30	30	30	30	30	30	30	30	30	30	
Tonroe	9.5	9.5	9.5	12	12	12	12	12	12	12	
Trillick	44.7	44.7	44.7	44.7	44.7	44.7	44.7	44.7	44.7	44.7	
North-West Total		553.2	757.9	808.6	821.4	962	1023.4	1023.4	1023.4	1023.4	1023.4

Table D-3 Forecast MEC of Existing and Committed Distribution-Connected Wind Farm Capacity

Area	110 kV Station	Maximum Export Capacity (MEC)									
		2016	2017	2018	2019	2020	2021	2022	2023	2024	2025
South-East	Arklow	79.7	79.7	83.7	83.7	83.7	89.7	89.7	89.7	89.7	89.7
	Ballydine	-	-	-	-	-	24	24	24	24	24
	Butlerstown	1.7	1.7	1.7	1.7	5.7	5.7	5.7	5.7	5.7	5.7
	Carlow	34.4	34.4	34.4	39.4	39.4	39.4	39.4	39.4	39.4	39.4
	Crane	5	5	5	5	7.5	7.5	7.5	7.5	7.5	7.5
	Croy	61.5	61.5	61.5	61.5	61.5	61.5	61.5	61.5	61.5	61.5
	Waterford	18	18	18	18	18	18	18	18	18	18
	Wexford	38.9	38.9	38.9	38.9	38.9	38.9	38.9	38.9	38.9	38.9
South-East Area Total		239.2	239.2	243.2	248.2	254.7	284.7	284.7	284.7	284.7	284.7
South-West	Athea	-	-	-	-	-	4	4	4	4	4
	Athea-2	-	-	-	4	4	81.6	81.6	81.6	81.6	81.6
	Aughinish	-	-	-	-	-	20	20	20	20	20
	Ballylickey	36.5	36.5	36.5	54	54	54	54	54	54	54
	Bandon	4.9	10.7	10.7	10.7	27	27	27	27	27	27
	Boggeragh	20	20	20	26	44	44	44	44	44	44
	Charleville	46	65.7	65.7	65.7	65.7	65.7	65.7	65.7	65.7	65.7
	Coomataggart	-	64.2	64.2	64.2	70.2	70.2	70.2	70.2	70.2	70.2
	Cordal	-	107.8	107.8	107.8	111.6	111.6	111.6	111.6	111.6	111.6
	Cloghboola	20	32	32	44.6	44.6	44.6	44.6	44.6	44.6	44.6
	Dunmanway	32.6	32.6	32.6	35.6	49.6	65.6	65.6	65.6	65.6	65.6
	Garrow	15	15	15	15	15	15	15	15	15	15
	Glentane	-	-	-	-	38.5	38.5	38.5	38.5	38.5	38.5
	Kilpaddoge	18	18	18	18	18	57.6	57.6	57.6	57.6	57.6
	Knockacummer	105	105	105	105	105	105	105	105	105	105
	Knockearagh	13.9	13.9	13.9	19.3	20.5	20.5	20.5	20.5	20.5	20.5
	Macroom	34.1	34.1	34.1	34.1	34.1	34.1	34.1	34.1	34.1	34.1
	Midleton	1.6	1.6	5.6	5.6	9.5	27.2	27.2	27.2	27.2	27.2
	Oughtragh	9.2	9.2	9.2	9.2	9.2	9.2	9.2	9.2	9.2	9.2
	Rathkeale	29.8	29.8	29.8	29.8	29.8	29.8	29.8	29.8	29.8	29.8
Reamore	57.4	57.4	57.4	57.4	70.9	96.2	96.2	96.2	96.2	96.2	
Tralee	45.9	45.9	45.9	45.9	47.6	47.6	47.6	47.6	47.6	47.6	
Trien	66.1	66.1	66.1	66.1	66.1	66.1	66.1	66.1	66.1	66.1	
South-West Area Total		609	818.5	822.5	877	993.9	1194.1	1194.1	1194.1	1194.1	1194.1

Table D-6 Existing and Proposed Northern Ireland Generating Plant Contract Details

Generation Unit	Fuel Type	Contract	
		Type	Details
Ballylumford ST 4	GAS/HFO	IPP	See Note 1
Ballylumford ST 5	GAS/HFO	IPP	See Note 1
Ballylumford CCGT 21	GAS/GASOIL	Power NI (PPB)	See Note 2
Ballylumford CCGT 22	GAS/GASOIL	Power NI (PPB)	See Note 2
Ballylumford CCGT 20	STEAM	Power NI (PPB)	See Note 2
Ballylumford CCGT 10	GAS/GASOIL	Power NI (PPB)	See Note 2
Ballylumford GT 7	GASOIL	IPP	Independent from 01/11/12
Ballylumford GT 8	GASOIL	IPP	Independent from 01/11/12
Kilroot ST 1	COAL/OIL	IPP	Independent from 01/11/10; See Note 3
Kilroot ST 2	COAL/OIL	IPP	Independent from 01/11/10; See Note 3
Kilroot GT 1	GASOIL	IPP	Independent from 01/11/12
Kilroot GT 2	GASOIL	IPP	Independent from 01/11/12
Kilroot GT 3	GASOIL	IPP	Commenced Operation 01/03/2009
Kilroot GT 4	GASOIL	IPP	Commenced Operation 01/03/2009
Coolkeeragh GT8	GASOIL	IPP	Independent from 01/02/2013
Coolkeeragh CCGT	GAS/GASOIL	IPP	Commenced Operation 01/04/2005
Moyle	DC LINK		See Note 4

NOTE 1: This is an independent Power Producer (IPP). Ballylumford ST4 and ST5 are contracted to provide a total capacity of 250 MW of local reserve until the end of 2018. There is an option for SONI to extend this by a further two years if deemed required.

NOTE 2: In a Generator Unit Agreement (GUA) with Power NI Energy Limited’s Power Procurement Business (PPB). The contract expiry date is 23rd September 2018 (with a five year extension option)³.

NOTE 3: Kilroot ST1 and ST2 are currently due to be decommissioned by 2024.

NOTE 4: Capacity is auctioned regularly (daily, monthly, seasonally and annually) to the market participants. Capacity is also available in SEM through implicit auction process.

3. <https://www.uregni.gov.uk/publications/gua-decision-paper>

D.2 Generation Dispatch Details

Table D-7 through to Table D-9 lists generation dispatch profiles. These dispatch profiles are used for the purposes of the short circuit current level analyses and power flow diagrams. In the tables the SV column represents the dispatch at summer valley, SP denotes the summer peak dispatch and WP denotes the winter peak dispatch.

For the purpose of short circuit current level studies, wind farms were dispatched at 10% of their rated capacity for winter peak cases. Wind farms were not dispatched in summer valley cases. These dispatches are given in Table D-7 and Table D-8.

For the purpose of power flow diagram dispatches, wind farms were dispatched at 30% of their rated capacity for winter peak cases. Wind farms were dispatched at 10% for summer peak and summer valley cases. These dispatches are given in Table D-9.

The values shown are in exported terms. They are the net of each generation unit's own consumption. They indicate the power delivered to the transmission system.

In all instances, a dispatch of 0 MW indicates that the unit is synchronised to the system, but dispatched at 0 MW. This scenario is only used for the winter peak short circuit current level studies. In all other dispatch profiles, unless a MW value is provided for the generator, the unit is not dispatched and not synchronised to the system.

It should be noted that station demand projections are developed from the system demand forecasts on a top-down basis. The projections use a forecast of transmission losses. The transmission loss figures calculated by the network models used in this TYTFS may differ from the forecast figures. Hence the dispatch totals may differ from the system demand forecasts in Table 3-1 in Chapter 3.

Table D-7 Dispatch Profiles – Ireland Short Circuit

Area	Generation Station	Unit ID	2016		2019		2022		
			SV	WP	SV	WP	SV	WP	
Dublin	Dublin Bay Power	DB1	345	365	236	345	276	325	
	EWIC	EW1	100	350	100	350	100	350	
	Huntstown	HNC	-	294	-	236	-	216	
	Huntstown	HN2	300	350	300	320	250	380	
	Liffey Hydro	LI1	-	10	-	10	-	14	
	Liffey Hydro	LI2	-	10	-	10	-	14	
	Liffey Hydro	LI4	-	4	-	4	-	4	
	North Wall	NW5	-	60	-	0	-	0	
	Poolbeg	PBC	-	300	-	295	-	158	
	Turlough Hill	1,2,3,4	-120	271	-245	205	-145	212	
	Elm Park Development (3)	-	-	0.6	-	0	-	0	
	Keelings CHP	-	-	1	-	1	1	1.6	
	Kilbush Nurseries CHP	-	-	1	-	1	1	1	
	Installed wind	-	-	5.6	-	21.9	-	28.3	
Dublin Area Total			625	2022.2	391	1798.9	483	1703.9	
Midlands	Cuilleen	-					-	0	
	Edenderry Power	ED1	82	91	64	91	91	101	
	Edenderry PCP	ED3	-	0	-	0	-	0	
	Edenderry PCP	ED5	-	0	-	0	-	0	
	Rhode PCP	RP1	-	0	-	0	-	0	
	Rhode PCP	RP2	-	0	-	0	-	0	
	Rhode Biomass	RP3			-	12	10	10	
	Suir	-						-	0
	West Offally Power	WO4	92	128	55	119	-	0	
	Dublin Waste to Energy	-	-	0	-	0	35	44	
	Dairygold Mitchelstown	-	-		-	3	3	3	
	Derryclure CHP	-	-	8	-	7	5	8	
Installed wind	-	-	64.6	-	82.5	-	106.9		
Midlands Area Total			174	291.6	119	314.5	144	272.9	

Table D-7 Dispatch Profiles – Ireland Short Circuit

Area	Generation Station	Unit ID	2016		2019		2022	
			SV	WP	SV	WP	SV	WP
Mid-West	Ardnacrusha	AA1	-	15	-	15	-	9
	Ardnacrusha	AA2	-	15	-	15	-	22
	Ardnacrusha	AA3	-	15	-	15	-	9
	Ardnacrusha	AA4	-	20	-	15	-	23
	Aughinish	SK3	50	70	60	70	50	70
	Aughinish	SK4	50	70	60	70	50	70
	Cahernagh Mid Merit	MP1					-	0
	Moneypoint	MP1	94	234	187	187	131	225
	Moneypoint	MP2	-	234	-	187	131	225
	Moneypoint	MP3	-	234	-	187	-	225
	Tarbert	TB1	-	0	-	0	-	0
	Tarbert	TB2	-	0	-	0	-	0
	Tarbert	TB3	-	0	-	0	-	0
Tarbert	TB4	-	0	-	0	-	0	
Tynagh	TY	-	380	-	316	-	385	
Installed wind	-	-	15.2	-	23.6	-	25.5	
Mid-West Area Total			194	1302.2	307	1100.6	362	1288.5
North-East	Bailie Foods CHP	-	-	1	-	1	1	1
	Corranure LFG	-			-	0	-	0.5
	Knockharley Landfill	-	-	4	-	4	3	3
	Meath Waste to Energy	-	-	13	9	13	13	14
	Rathdrinagh Biogas	-			-	1	2	2
	Whiteriver LFG	-	-	1.3	-	1	1	1
	Installed wind	-	-	12.1	-	27.9	-	63.7
North-East Area Total			-	31.4	9	47.9	20	85.2

Table D-7 Dispatch Profiles – Ireland Short Circuit

Area	Generation Station	Unit ID	2016		2019		2022	
			SV	WP	SV	WP	SV	WP
North-West	Erne	ER1	-	5	-	5	-	10
	Erne	ER2	-	5	-	5	-	10
	Erne	ER3	-	15	-	15	-	15
	Erne	ER4	-	15	-	15	-	15
	Lough Ree Power	LR4	73	82	64	73	-	0
	Tawnaghmore Peaking	-	-	0	-	0	-	0
	Tawnaghmore Peaking	-	-	0	-	0	-	0
	AMETS Belmullet	-			-	5	5	5
	Clady Hydro	-	-	4.3	-	3	-	0
	Connaught Landfill	-	-	0.8	-	0	-	0
	Mayo Power Biomass CHP	-	-	46.6	20	45	30	40
	Installed wind	-	-	103.8	-	178.7	-	220.6
North-West Area Total			73	277.5	84	344.7	35	315.6
South-East	Great Island	GI4	295	380	236	354	236	344
	Ballynagran LFG	-	-	3	-	3	2	3
	Nore Power	NO1					-	0
	Ballyshannon Farms	-	-	0.2	-	0	-	0
	Glanbia Ballyraggett CHP	-			-	5	4	5
	Installed wind	-	-	32.5	-	32.6	-	32.7
South-East Area Total			295	415.7	236	394.6	242	384.7

Table D-7 Dispatch Profiles – Ireland Short Circuit

Area	Generation Station	Unit ID	2016		2019		2022	
			SV	WP	SV	WP	SV	WP
South-West	Aghada	AD1	-	150	-	58	-	0
	Aghada	AT1	-	0	-	0	-	0
	Aghada	AT2	-	0	-	0	-	0
	Aghada	AT4	-	0	-	0	-	0
	Aghada CCGT	ADC	-	322	225	293	225	332
	Lee Hydro	LE1	-	10	-	10	-	14
	Lee Hydro	LE2	-	10	-	10	-	14
	Lee Hydro	LE3	-	4	-	4	-	5
	Marina	MRT	-	0	-	0	-	0
	Pfizer Askeaton	-	-	5	-	5	4	5
	Whitegate CCGT	WG	297	380	238	361	198	356
	Adambridge	-	-	3	-	3	2	2.9
	Carbery Milk Products CHP	-	-	4	-	3	3	4
	FMC Gas Turbine ext.	-	-	-	-	1	1	0
	Shamrock Renewable Fuels	-	-	-	-	5	6	12.4
Installed wind	-	-	93.5	-	154.2	-	224.2	
South-West Area Total			297	981.5	463	907.2	439	969.5

Table D-8 Dispatch Profiles – Northern Ireland Short Circuit

Area	Generation Station	Unit ID	2016		2019		2022	
			SV	WP	SV	WP	SV	WP
Northern Ireland	Ballylumford CCGT 10	B10	68	98	-	78	-	90
	Ballylumford CCGT 21	B31	-	151	-	146	-	150
	Ballylumford CCGT 22	B32	-	151	-	149	-	150
	Ballylumford CCGT 20	-	-	165	-	161	-	170
	Ballylumford GT7	BGT1	-	0	-	0	-	0
	Ballylumford GT8	BGT2	-	0	-	0	-	0
	Ballylumford ST4	B4	-	0				
	Ballylumford ST5	B5	-	0				
	CAES	-				33.6	-	33.6
	Coolkeeragh CCGT	C30	260	399	260	350	260	390
	Coolkeeragh GT8	CGT8	-	0	-	0	-	0
	Biomass Maydown	-	10	17.6	-	17.6	17.6	17.6
	Biomass Rosebank	-			-	10	10	10
	Kilroot ST1	K1	102	166	110	175	138	180
	Kilroot ST2	K2	-	166	110	175	-	180
	Kilroot GT1	KGT1	-	0	-	0	-	0
	Kilroot GT2	KGT2	-	0	-	0	-	0
	Kilroot GT3	KGT3	-	0	-	0	-	0
	Kilroot GT4	KGT4	-	0	-	0	-	0
	Moyle (Import positive)	-	100	150	100	150	100	150
	Installed Wind	-	-	85.9	-	133.6	-	143.3
Installed PV	-			9.8	0	13.3	0	
Installed Tidal	-			-	3	-	21	
Northern Ireland Area Total			540	1549.5	589.8	1581.8	538.9	1685.5

Table D-9 Dispatch Profiles – Power Flow Diagrams

Area	Generation Station	Unit ID	2016			2025		
			SV	SP	WP	SV	SP	WP
Dublin	Dublin Bay Power	DB1	250	315	295	163	345	364
	EWIC	EW1	100	350	300	100	350	300
	Huntstown	HNC	-	280	194	-	-	-
	Huntstown	HN2	250	320	350	194	350	370
	Liffey Hydro	LI1	-	15	15	-	15	15
	Liffey Hydro	LI2	-	15	15	-	15	15
	Liffey Hydro	LI4	-	4	4	-	4	4
	North Wall	NW5	-	-	-	-	-	-
	Poolbeg	PBC	-	50	50	-	-	-
	Turlough Hill	1,2,3,4	-260	187.8	220.6	-258	124.8	210.6
	Installed wind	-	1.8	1.8	5.4	11.3	13.5	34.9
Dublin Area Total			341.8	1538.6	1449	210.3	1217.3	1313.5
Midlands	Cuilleen	-				-	-	-
	Edenderry Power	ED1	119	119	119	119	119	119
	Edenderry PCP	ED3	-	-	-	-	-	-
	Edenderry PCP	ED5	-	-	-	-	-	-
	Rhode PCP	RP1	-	-	-	-	-	-
	Rhode PCP	RP2	-	-	-	-	-	-
	Suir	-				-	-	-
	West Offally Power	WO4	138	138	138	-	-	-
	Installed wind	-	39.3	42.3	140.4	88.7	88.7	236.4
Midlands Area Total			296.3	299.3	397.4	207.7	207.7	355.4

Table D-9 Dispatch Profiles – Power Flow Diagrams

Area	Generation Station	Unit ID	2016			2025		
			SV	SP	WP	SV	SP	WP
Mid-West	Ardnacrusha	AA1	-	21	21	-	21	21
	Ardnacrusha	AA2	-	22	22	-	22	22
	Ardnacrusha	AA3	-	19	19	-	19	19
	Ardnacrusha	AA4	-	24	24	-	24	24
	Aughinish	SK3	-	80	80	80	80	80
	Aughinish	SK4	-	80	80	80	80	80
	Cahernagh Mid Merit	-				-	-	
	Moneypoint	MP1	150	262	262	262	262	262
	Moneypoint	MP2	-	262	262	-	262	262
	Moneypoint	MP3	-	262	262	262	262	262
	Tarbert	TB1	-	-	-			
	Tarbert	TB2	-	-	-			
	Tarbert	TB3	-	-	-			
	Tarbert	TB4	-	-	-			
	Tynagh	TY	-	266	-	-	266	-
	Installed wind	-	15.2	15.2	17.9	25.5	25.5	76.8
Mid-West Area Total			165.2	1313.2	1049.9	709.5	1323.5	1108.8
N-East	Installed Wind	-	11.5	11.5	34.4	38.3	59.6	111.9
North-East Area Total			11.5	11.5	34.4	38.3	59.6	111.9

Table D-9 Dispatch Profiles – Power Flow Diagrams

Area	Generation Station	Unit ID	2016			2025		
			SV	SP	WP	SV	SP	WP
Northern Ireland	Ballylumford CCGT 10	B10	-	-	78	-	-	92
	Ballylumford CCGT 21	B31	-	-	146	68	140	146
	Ballylumford CCGT 22	B32	-	-	146	-	140	146
	Ballylumford CCGT 20	-	-	-	156	47	150	156
	Ballylumford GT7	BGT1	-	-	-	-	-	-
	Ballylumford GT8	BGT2	-	-	-	-	-	-
	Ballylumford ST4	B4	-	-	-			
	Ballylumford ST5	B5	-	-	-			
	CAES	-				-100	33.6	220
	Coolkeeragh CCGT	C30	260	389	399	260	380	399
	Coolkeeragh GT8	CGT8	-	-	-	-	-	-
	Biomass Maydown	-	17.6	17.6	17.6	17.6	17.6	17.6
	Biomass Rosebank	-				9.9	9.9	9.9
	Kilroot ST1	K1	110	161	166			
	Kilroot ST2	K2	110	161	166			
	Kilroot GT1	KGT1	-	-	-	-	-	-
	Kilroot GT2	KGT2	-	-	-	-	-	-
	Kilroot GT3	KGT3	-	-	-	-	-	-
	Kilroot GT4	KGT4	-	-	-	-	-	-
	Moyle (Import positive)	-	100	100	150	-80	100	150
Installed Wind	-	72.6	72.6	257.7	161.7	161.7	391.1	
Installed PV	-				51.6	12.9	-	
Installed Tidal	-				63	21	63	
Northern Ireland Area Total			670.2	901.2	1682.3	498.8	1166.7	1790.6

Table D-9 Dispatch Profiles – Power Flow Diagrams

Area	Generation Station	Unit ID	2016			2025		
			SV	SP	WP	SV	SP	WP
North-West	Erne	ER1	-	22	22	-	22	22
	Erne	ER2	-	23	23	-	23	23
	Erne	ER3	-	10	10	-	10	10
	Erne	ER4	-	10	10	-	10	10
	Lough Ree Power	LR4	91	91	91	-	-	-
	Tawnaghmore Peaking	-	-	-	-	-	-	-
	Tawnaghmore Peaking	-	-	-	-	-	-	-
	Mayo Power Biomass CHP	-				40	40	40
	Installed wind	-	65.6	65.6	312.4	195.5	195.5	479.3
North-West Area Total			156.6	221.6	468.4	235.5	300.5	584.3
South-East	Great Island	GI4	-	315	403	-	374	403
	Nore Power	NO1				-	-	-
	Installed wind	-	31.6	31.6	94.9	33.9	33.9	98.2
South-East Area Total			31.6	346.6	497.9	33.9	407.9	501.2
South-West	Aghada	AD1	-	-	-	-	245	-
	Aghada	AT1	-	-	-	-	-	-
	Aghada	AT2	-	-	-	-	-	-
	Aghada	AT4	-	-	-	-	-	-
	Aghada CCGT	ADC	222	312	400	222	351	390
	Lee Hydro	LE1	-	15	15	-	15	15
	Lee Hydro	LE2	-	15	15	-	15	15
	Lee Hydro	LE3	-	8	8	-	8	8
	Marina	MRT	-	-	-	-	-	58
	Whitegate CCGT	WG	200	317	406	110	356	396
	Installed wind	-	90	97.8	280.2	200.8	211.3	544.3
South-West Area Total			512	764.8	1124.2	532.8	1201.3	1426.3

All-Island Ten Year

**Transmission Forecast
Statement** **2016**

Appendix E

Appendix E: Short Circuit Currents

E.1 Background of Short Circuit Currents

The main driver for calculating short circuit current levels is safety. All transmission system equipment must be capable of carrying very high currents. These high currents typically occur in the event of a short circuit fault. In particular, circuit breakers must be capable of closing onto a fault and opening to isolate a fault.

Their correct operation minimises risk to human life and prevents damage to transmission system equipment. It is also crucial for maintaining transmission system stability, security and quality of supply.

Short circuit current levels also give an indication of the electrical strength of the transmission system at each station. This provides an indication of the suitability of a station for connection of 'voltage sensitive' equipment.

A station with a high short circuit current level will be more attractive to these types of load. This is due to strong generation infeeds minimising distortions in voltage and frequency caused by transmission system disturbances. Similarly, generators will have less difficulty to ride through faults and maintain stability when connected to stations with high short circuit current levels.

Short circuit current levels vary across the transmission system. They are affected by the transmission system topology, system impedance and the available short circuit contribution from rotating machines (i.e. generators and large motors). Changes in the transmission system topology or the addition/retirement of generation units can bring about an increase/reduction in the short circuit current levels on the transmission system. Similarly, seasonal variations in generation dispatches and demand levels combined with possible transmission system sectionalising or plant outages will result in variations of short circuit current levels at different locations. To ensure safe and reliable operation of the transmission system and customer's equipment at all times, two types of short circuit current level calculations are carried out:

- Maximum short circuit current levels are required for the specification of transmission system equipment and for connections to the transmission system. Plant in substations is typically subjected to the most onerous short circuit currents. The high capital costs of HV equipment means that it is important to predict the maximum short circuit current the equipment may see in its lifetime, and this must be specified to a rating above the maximum expected short circuit current level. Also, for customers, the design and specification of equipment at lower voltage levels will depend on the short circuit level at the transmission connection point.
- Minimum short circuit current levels are required to guarantee reliable and coordinated operation of protection systems or to assess the suitability of a station for the connection of 'voltage sensitive' equipment. Minimum short circuit current levels are also required at the design stage of generation plants to ensure fault ride through capabilities are in accordance with Grid Code requirements.

E.2 The Nature of Short Circuit Currents

The plot in Figure E-1 shows a typical short circuit current waveform. Short circuit current is normally made up of a symmetrical AC component, with a decay rate, and a DC offset component, which has a much faster decay rate. The combination of AC and DC components results in an asymmetrical current waveform.

While the AC component is always present in the short circuit current, the DC offset is dependent on the instant that the fault occurs within the voltage waveform. For the purposes of this document, it is assumed that the fault occurs at the instant of maximum DC offset in the short circuit current.

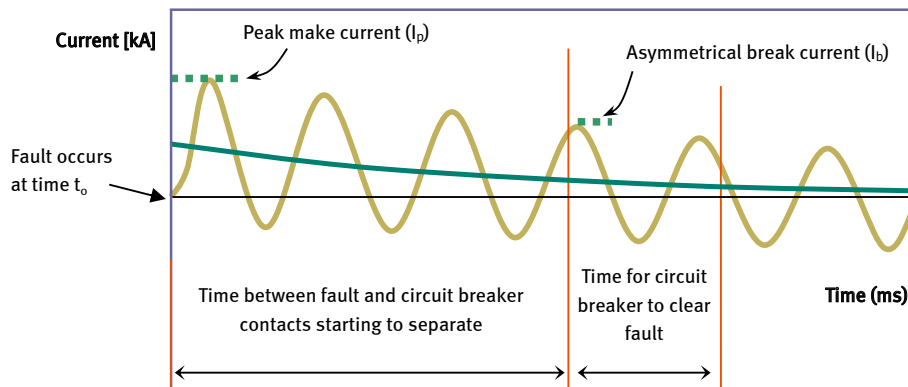

Figure E-1 Typical Short Circuit Current

The DC component of a short circuit current decays exponentially. Its rate of decay is influenced by the individual ratios of the reactance (X) to the resistance (R) of the paths back to the generators feeding power to the fault (the X/R ratio). Transmission nodes where large generators can have high X/R ratios, which may result in a slower decay time for the DC component of the short circuit current.

The AC component of a short circuit current also decays with time. This is due to the changes in the synchronous generators internal reactance and, thus, the AC reduction effect is more pronounced in the vicinity of large generation plants. The internal impedance of a synchronous generator is not constant after the start of the fault. It increases progressively and the short circuit current contribution becomes weaker, passing through three characteristic stages:

- Subtransient: (approx. 0.01 to 0.1 sec). Short-circuit current (RMS value of the AC component) is high: 5 to 10 times permanent rated current. This is called sub-transient short-circuit current, I_k'' .
- Transient: (between 0.1 and 1 sec). Short-circuit current (RMS value of the AC component) drops to between 2 and 6 times rated current. This is called transient short-circuit current, I_k' .
- Continuous: Short-circuit current (RMS value of the AC component) drops to between 0.5 and 2 times rated current. This is called steady-state short-circuit current, I_k .

E.3 Duty of Circuit Breakers

Over the duration of a fault the switchgear has to be able to withstand two events, namely the fault initiation and then the fault clearance. The short circuit currents at these two instances are referred to as the Make current and the Break current respectively.

- (i) The make current (I_p) is the maximum instantaneous current that the circuit breaker is called to withstand. The initiation of a fault causes an instantaneous peak current which results in the generation of electromechanical forces along the busbars and transmission lines. An example of such a fault initiation would be a circuit breaker energising a line that is still earthed following maintenance, hence the term Make Current.

Make current is expressed in peak values and is comprised of an AC and a DC component. Essentially, the make current is the maximum instantaneous peak of the short circuit current waveform, and this will occur at approximately 10 milliseconds after the instant of fault (see Figure E-1), whether the fault is energised through a circuit breaker or it spontaneously occurs on the transmission system. Circuit breakers are typically rated approximately 2.5 times higher for make duty than for break duty, as per IEC 62271-100 standard.

(ii) After the fault initiation, there is a time period during which the protection scheme will identify the fault, make a decision and then instruct the relevant circuit breaker to open to interrupt the fault. This could take anything from 10 ms in modern fast protection systems to 60 ms in older systems. At this point the circuit breaker begins to open and it takes a certain time period before the contacts actually separate, normally around two cycles or 40 ms in modern switchgear equipment. The total time from the start of the fault until the breaker opening or fault clearance time can vary from 50 ms to 120 ms, depending on the protection system. In some cases; if main protection fails and back-up main protection is not installed; clearance times can be considerably longer than 120 ms.

At the point of physical separation, the short circuit current forms an arc and the thermal energy generated by this arc has to be dissipated as the short circuit current is interrupted. The short circuit current when this interruption occurs is referred to as the Break Current, I_b . This value is expressed in RMS (root mean square) terms and is comprised of an AC component and a DC component. Circuit breakers designed and tested in accordance with the IEC 62271-100 standard can interrupt any short circuit current up to its rated breaking current containing any AC component up to the rated value and, associated with it, any percentage DC component up to that specified (typically 30%).

The duty of the circuit breaker is calculated from the make and break current as a percentage of the circuit breaker rating.

E.4 Short Circuit Current Calculation Methodology

Engineering Recommendation G74 has been applied to all short circuit studies reported in this document. Some of the general assumptions applied include:

- Short circuit level contribution from loads has been considered following G74 recommendations. The demand at each node is assumed to contribute 1 MVA of induction motor fault infeed per MW of load. A constant X/R ratio of 2.76 is assumed for all of the loads,
- A break time of 50 ms is assumed typical for the circuit breakers at 110 kV, 220 kV, 275 kV and 400 kV.

Winter Peak study results give an indication of the maximum prospective short circuit current levels on the transmission system. For winter peak studies, all generators have been included in the calculations. A merit order economic dispatch has been used and to enable maximum short circuit current level to be calculated, any generators that were not dispatched have been switched in with 0 MW output, thus contributing to short circuit current levels.

Summer Night Valley study results give an indication of the minimum short circuit current levels to be expected on the transmission system under normal transmission system operating conditions (i.e. maintenance outages are not considered in this section¹). For summer night valley studies, only generators dispatched on a merit order are considered in the model.

E.5 Short Circuit Currents in Ireland

E.5.1 Methodology Used in Ireland

Short circuit current levels are calculated in accordance with the UK Engineering Recommendation G74, which is a computer based analysis, based on the International Standard IEC60909. Compliance with G74 includes:

- Short circuit contributions from rotating plant, including induction motors embedded in the general load,
- Comprehensive plant parameters including impedances, transformer winding and earthing configurations,
- Pre-fault voltage levels at each node which should be obtained from a credible, pre-fault load flow study, Pre-fault transformer tap settings should also be obtained from the load flow study.

1. Minimum fault levels including maintenance outages are currently provided to generator applicants wishing to connect to the transmission system as part of the connection offer process to allow developers to design the plant in accordance with the Grid Code requirements.

The short circuit current level network model includes the following component parameters:

- Transformer impedance variation with tap position,
- Zero sequence mutual coupling effect,
- Saturated generator reactance values,
- Power station auxiliaries short circuit current level contributions.

The calculation of the X/R ratios, used by EirGrid, is undertaken in accordance with IEC60909-0 Method B. Method B is currently considered to be the most appropriate general purpose method for calculating DC short circuit currents in the transmission system of Ireland. The use of this calculation method is currently under review by EirGrid.

The transmission system of Ireland is designed and operated to maintain RMS break short circuit levels in accordance with EirGrid Grid Code CC.8.6. A summary of these requirements is set out in Table E-1. In designing the system, a 10% safety margin is applied.

It should be noted that the EirGrid Grid Code Version 4.0 (released in December 2011) contains a modification which stipulates that short circuit current levels at designated stations, in Ireland may be allowed to increase to 31.5 kA. If necessary, the equipment at these stations is to be modified or replaced in order to comply with this new rating. The stations currently designated for operation of the 110 kV equipment up to 31.5 kA, as proposed by the TSO, are; Barnahely, Cloghran, College Park, Corduff, Finglas, Kilbarry, Knockraha, Louth, Marina, Raffeen, Tarbert and Trabeg. EirGrid will annually publish an updated list of designated stations.

Circuit breakers with a higher rating than the current levels may be necessary for a number of reasons, including, but not limited to the need to provide an adequate safety margin or to cater for a high DC component in the short circuit current.

E-4

Voltage Level (kV)		Standard Equipment Short Circuit Current Rating (kA)
400		50
220		40
110	Outside the Dublin Area ²	25
	Designated sites	31.5

Table E-1 Ireland station equipment rating range by voltage level

E.5.2 Analysis

The generation dispatches used in the short circuit analysis are shown in Table D-7 in Appendix D.

The total RMS break current at a busbar is an indication of the short circuit level that one could expect at that point in the transmission system. However, they do not necessarily represent the short circuit current that could flow through each individual breaker, which may be lower.

2. New equipment installed at 110 kV level must have a short circuit rating of 31.5 kA.

E.5.3 Ireland Short Circuit Currents Level Results

Tables E-2 to E-4 list subtransient (I_k''), transient (I_k') currents and X/R ratios for single-phase to earth and balanced three-phase faults for transmission system busbars of Ireland. These are presented for maximum winter peak and minimum summer valley intact system demand conditions for 2016, 2019 and 2022. From these values, the relevant currents required to assess circuit breaker duty can be derived using the following equations:

- Peak Make current (I_p)

$$I_p = \sqrt{2} \cdot \left[1.02 + 0.98 \cdot e^{-3 \frac{R}{X}} \right] \cdot I_k''$$

- AC component ($I_{RMS_AC_b}$) of short-circuit current at a selected time of break (t_b)

$$I_{RMS_AC_b} = I_k' + (I_k'' - I_k') \cdot e^{-\frac{t_b}{40ms}}$$

- DC component (I_{DC_b}) of short-circuit current at a selected time of break (t_b)

$$I_{DC_b} = \sqrt{2} \cdot I_k'' \cdot e^{-2 \cdot \pi \cdot 50 \cdot t_b \cdot \frac{R}{X}}$$

- Break current (I_b) at a selected time of break (t_b)

$$I_b = \sqrt{I_{DC_b}^2 + I_{RMS_AC_b}^2}$$

Table E-2 Ireland Short Circuit Currents for Maximum and Minimum Demand in 2016

Station	Summer						Winter					
	Three phase			Single phase			Three phase			Single phase		
	X/R Ratio	I_k'' [kA]	I_k'' [kA]	X/R Ratio	I_k'' [kA]	I_k'' [kA]	X/R Ratio	I_k'' [kA]	I_k'' [kA]	X/R Ratio	I_k'' [kA]	I_k'' [kA]
Adamstown 110 kV	13.98	10.55	9.43	8.84	11.82	11.30	13.82	12.84	11.32	8.47	13.76	13.12
Agannygal 110 kV	2.77	4.59	4.42	3.81	3.97	3.93	3.02	6.16	5.51	4.27	4.79	4.65
Aghada 110 kV	5.12	7.35	6.84	6.01	8.79	8.53	4.62	9.97	9.43	5.68	11.24	11.00
Aghada A 220 kV	8.87	7.86	7.07	9.60	10.30	9.81	12.57	18.23	16.17	13.78	20.37	19.42
Aghada B 220 kV	11.64	8.99	7.97	11.14	11.57	10.95	13.39	17.54	15.58	11.51	19.93	19.00
Aghada C 220 kV	8.81	7.73	6.97	9.23	10.13	9.65	12.17	17.66	15.71	12.27	19.81	18.91
Aghada D 220 kV	8.81	7.73	6.97	9.23	10.13	9.65	12.17	17.66	15.71	12.27	19.81	18.91
Ahane 110 kV	5.37	9.78	8.95	5.99	8.69	8.46	4.94	14.26	13.14	5.82	10.89	10.66
Anner 110 kV	3.87	5.73	5.38	4.42	4.69	4.61	3.91	7.10	6.56	4.49	5.31	5.20
Ardnacrusha 110 kV	5.78	10.41	9.44	6.84	11.98	11.52	6.41	17.00	15.19	8.04	17.00	16.35
Arigna 110 kV	3.76	5.90	5.61	4.74	4.71	4.65	3.77	7.96	7.23	4.93	5.57	5.44
Arklow 110 kV	10.31	7.59	7.22	11.10	9.39	9.19	10.96	9.41	8.70	11.85	11.16	10.81

Table E-2 Ireland Short Circuit Currents for Maximum and Minimum Demand in 2016

Station	Summer						Winter					
	Three phase			Single phase			Three phase			Single phase		
	X/R Ratio	Ik'' [kA]	Ik'' [kA]	X/R Ratio	Ik'' [kA]	Ik'' [kA]	X/R Ratio	Ik'' [kA]	Ik'' [kA]	X/R Ratio	Ik'' [kA]	Ik'' [kA]
Arklow 220 kV	9.24	6.82	6.44	10.63	6.54	6.41	8.96	8.42	7.98	10.47	7.56	7.44
Artane 110 kV	13.28	9.66	9.02	6.33	11.74	11.41	13.34	13.00	11.85	5.71	15.04	14.49
Arva 110 kV	3.82	7.74	7.26	4.83	6.24	6.13	3.69	9.85	8.96	4.87	7.16	6.99
Athea 110 kV	6.78	7.24	6.79	7.74	8.02	7.82	8.12	12.16	10.50	9.57	11.28	10.75
Athlone 110 kV	4.50	7.11	6.68	5.26	7.88	7.69	4.11	8.38	7.76	4.91	8.85	8.61
Athy 110 kV	3.32	5.45	5.23	4.47	4.59	4.54	3.11	6.45	6.08	4.35	5.16	5.08
Aughinish 110 kV	9.15	8.73	7.65	11.13	9.73	9.24	8.31	10.28	9.23	10.40	10.75	10.34
Ballybeg 110 kV	9.53	6.10	5.83	9.78	7.22	7.09	10.38	6.57	6.18	10.71	7.52	7.34
Ballydine 110 kV	3.97	6.40	6.03	3.82	5.42	5.33	3.91	7.78	7.24	3.78	6.08	5.96
Ballylickey 110 kV	2.74	2.51	2.40	3.83	1.68	1.66	2.84	3.30	3.06	4.01	1.89	1.86
Ballynahulla 110 kV	-	-	-	-	-	-	8.45	11.76	10.79	10.10	11.11	10.81
Ballynahulla 220 kV	-	-	-	-	-	-	6.74	10.28	9.41	7.48	10.65	10.31
Ballyvouskill 110 kV	-	-	-	-	-	-	12.30	11.46	10.31	12.28	12.24	11.77
Ballyvouskill 220 kV	-	-	-	-	-	-	6.60	11.22	10.19	7.55	12.67	12.19
Ballywater 110 kV	4.65	4.90	4.74	3.32	5.20	5.14	4.66	6.08	5.74	3.20	5.98	5.86
Baltrasna 110 kV	6.38	9.42	8.86	7.45	7.47	7.35	5.94	10.77	10.23	7.18	8.18	8.07
Bancroft 110 kV	11.07	13.31	11.88	6.35	14.55	13.93	13.87	9.07	8.22	8.83	9.25	8.93
Bandon 110 kV	3.34	5.01	4.68	4.30	5.16	5.04	3.01	6.76	6.13	4.13	6.36	6.17
Banoge 110 kV	6.11	5.38	5.19	6.84	4.94	4.88	6.00	6.39	6.05	6.80	5.48	5.39
Barnahealy A 110 kV	5.45	9.56	8.72	5.99	10.43	10.07	4.55	14.12	13.01	5.37	13.85	13.47
Barnahealy B 110 kV	7.34	9.32	8.48	7.74	10.06	9.71	6.68	13.77	12.60	7.34	13.32	12.93
Baroda 110 kV	4.30	7.37	6.89	5.07	8.61	8.39	4.00	9.21	8.57	4.86	10.22	9.95
Barrymore 110 kV	4.03	6.53	6.13	4.93	4.29	4.23	3.75	8.71	8.21	4.88	4.96	4.91
Bellacorick A 110 kV	2.96	3.28	3.10	3.77	3.40	3.33	3.94	4.91	4.47	5.16	4.57	4.44
Binbane 110 kV	3.20	3.36	3.21	4.32	3.34	3.30	3.43	5.12	4.59	4.97	4.34	4.21
Blackrock 110 kV	8.78	12.49	11.25	2.38	10.79	10.46	10.99	11.51	10.46	2.85	9.92	9.64
Blake 110 kV	4.20	7.12	6.71	5.13	5.05	4.98	3.96	8.72	8.18	5.03	5.68	5.60
Boggeragh 110 kV	6.31	5.51	5.22	7.46	6.14	6.01	6.79	8.23	7.60	8.20	7.95	7.74
Booltiagh 110 kV	2.77	3.28	3.17	3.92	3.11	3.08	5.48	5.00	4.53	7.61	4.06	3.94
Brinny A 110 kV	3.22	4.58	4.30	4.18	4.36	4.27	2.91	6.02	5.52	4.02	5.22	5.09

Table E-2 Ireland Short Circuit Currents for Maximum and Minimum Demand in 2016

Station	Summer						Winter					
	Three phase			Single phase			Three phase			Single phase		
	X/R Ratio	Ik'' [kA]	Ik'' [kA]	X/R Ratio	Ik'' [kA]	Ik'' [kA]	X/R Ratio	Ik'' [kA]	Ik'' [kA]	X/R Ratio	Ik'' [kA]	Ik'' [kA]
Brinny B 110 kV	3.22	4.59	4.31	4.18	4.38	4.29	2.91	6.05	5.54	4.02	5.26	5.12
Butlerstown 110 kV	6.17	9.19	8.65	5.83	9.54	9.33	5.53	11.22	10.37	5.40	11.05	10.75
Cabra 110 kV	12.37	9.37	8.75	5.16	10.64	10.36	12.21	12.52	11.44	4.63	13.38	12.94
Cahir 110 kV	3.92	7.02	6.54	4.54	8.01	7.78	4.25	9.79	8.83	5.05	10.11	9.75
Carlow 110 kV	5.33	7.25	6.90	6.05	7.99	7.84	5.30	9.30	8.54	6.09	9.60	9.31
Carrickmines 220 kV	14.38	14.86	12.97	9.70	18.32	17.25	14.03	21.97	19.38	8.50	25.21	23.94
Carrickmines A 110 kV	21.15	14.97	13.27	16.72	16.79	16.01	31.70	13.31	12.02	23.61	14.06	13.54
Carrickmines B 110 kV	21.15	14.97	13.27	16.72	16.79	16.01	22.51	9.76	8.83	18.54	10.03	9.68
Carrick-on-Shannon 110 kV	4.40	9.38	8.72	5.08	10.37	10.09	4.10	12.76	11.51	4.94	13.06	12.59
Carrigadrohid 110 kV	6.56	8.70	7.97	7.22	8.18	7.95	6.26	13.50	12.31	7.17	10.64	10.38
Carrowbeg 110 kV	2.62	2.41	2.31	3.54	2.28	2.25	2.70	3.07	2.81	3.77	2.67	2.60
Cashla 110 kV	6.83	12.14	11.11	7.46	15.51	14.92	7.41	18.64	16.83	7.79	22.51	21.57
Cashla 220 kV	8.00	7.56	7.03	9.14	8.28	8.06	8.37	12.20	11.41	9.53	11.74	11.48
Castlebar 110 kV	2.97	3.98	3.76	3.80	4.27	4.18	3.35	5.86	5.15	4.46	5.54	5.31
Castledockrill 110 kV	6.87	6.39	6.15	4.92	7.79	7.67	6.92	8.10	7.63	4.70	9.24	9.02
Castlefarm A 110 kV	8.27	8.45	7.43	9.70	9.11	8.68	7.47	9.91	8.92	9.03	10.03	9.66
Castlefarm B 110 kV	8.29	8.43	7.41	9.71	9.10	8.67	7.49	9.89	8.91	9.04	10.02	9.65
Castleview 110 kV	4.59	9.53	8.71	4.94	7.71	7.52	3.79	13.87	12.80	4.53	9.52	9.34
Cathaleen's Fall 110 kV	4.22	6.15	5.77	4.97	6.85	6.69	5.44	11.66	9.87	6.41	10.82	10.24
Cauteen 110 kV	3.34	5.71	5.41	4.28	3.96	3.91	5.03	8.36	7.76	5.97	5.06	4.98
Central 110 kV	11.12	13.31	11.94	5.97	14.44	13.86	14.41	12.08	10.99	7.56	12.51	12.09
Charleville 110 kV	4.61	5.25	4.94	5.84	4.03	3.96	4.08	9.15	8.57	5.68	7.45	7.31
Cherrywood 110 kV	8.27	12.05	10.89	5.99	12.19	11.76	10.22	11.08	10.14	7.41	10.91	10.58
City West 110 kV	6.25	7.20	6.63	6.16	5.53	5.41	5.95	8.55	7.67	5.99	6.11	5.94
Clahane 110 kV	4.63	6.87	6.43	5.27	6.79	6.64	4.07	11.42	10.14	5.04	9.12	8.82
Clashavoon 220 kV	7.89	6.12	5.64	8.81	6.67	6.47	7.37	11.41	10.37	8.11	11.53	11.14
Clashavoon A 110 kV	7.77	9.53	8.70	8.68	10.83	10.45	8.05	15.81	14.26	9.32	15.81	15.26
Clashavoon B 110 kV	7.77	9.53	8.70	8.68	10.83	10.45	8.05	15.81	14.26	9.32	15.81	15.26
Cliff 110 kV	3.99	5.03	4.77	5.00	5.15	5.06	4.73	8.57	7.53	6.06	7.18	6.91
Clogher 110 kV	-	-	-	-	-	-	4.99	9.88	8.08	5.38	9.35	8.72

Table E-2 Ireland Short Circuit Currents for Maximum and Minimum Demand in 2016

Station	Summer						Winter					
	Three phase			Single phase			Three phase			Single phase		
	X/R Ratio	Ik'' [kA]	Ik'' [kA]	X/R Ratio	Ik'' [kA]	Ik'' [kA]	X/R Ratio	Ik'' [kA]	Ik'' [kA]	X/R Ratio	Ik'' [kA]	Ik'' [kA]
Cloghran 110 kV	7.28	14.20	12.97	7.34	13.43	13.04	8.65	20.87	19.18	8.76	21.85	21.19
Clonkeen A 110 kV	5.80	4.90	4.64	6.47	5.64	5.52	5.55	6.44	6.08	6.83	4.43	4.37
Clonkeen B 110 kV	5.85	4.85	4.60	6.51	5.60	5.49	5.77	9.13	8.13	4.60	9.86	9.43
Cloon 110 kV	4.40	6.50	6.15	5.29	4.72	4.66	4.24	8.44	7.85	5.26	5.47	5.38
College Park 110 kV	9.82	17.56	15.77	6.95	19.70	18.89	8.33	19.82	18.28	6.12	21.94	21.27
Cookstown 110 kV	6.73	8.95	8.29	5.66	7.18	7.03	8.49	6.88	6.38	6.96	5.68	5.56
Coolroe 110 kV	5.54	7.69	7.11	6.74	7.75	7.54	5.10	11.21	10.34	6.66	9.85	9.61
Coomagearlahy 110 kV	5.73	4.08	3.90	6.57	4.99	4.90	6.11	7.56	6.60	6.58	8.34	7.91
Corderry 110 kV	3.70	6.11	5.80	4.64	6.19	6.09	3.91	9.02	7.93	5.18	7.98	7.66
Corduff 110 kV	10.73	19.42	17.28	11.57	22.02	21.02	9.48	22.86	20.88	10.63	25.41	24.54
Corduff 220 kV	15.05	15.31	13.51	13.80	18.99	17.97	15.95	25.59	22.55	13.65	28.87	27.44
Corkagh 110 kV	17.74	10.92	9.71	12.27	12.21	11.66	18.09	13.36	11.72	11.99	14.28	13.59
Corraclassy 110 kV	4.35	5.61	5.28	5.39	4.61	4.53	4.37	6.98	6.52	5.57	5.17	5.08
Cow Cross 110 kV	5.00	9.60	8.74	5.21	8.78	8.53	4.14	14.12	13.00	4.71	11.18	10.93
Crane 110 kV	6.46	6.94	6.63	6.53	7.59	7.46	6.63	9.05	8.31	6.57	9.08	8.81
Cromcastle A 110 kV	12.05	9.61	8.75	7.54	10.83	10.44	11.98	12.30	10.93	7.16	13.11	12.54
Cromcastle B 110 kV	12.05	9.61	8.75	7.54	10.83	10.44	11.98	12.30	10.93	7.16	13.11	12.54
Croy 110 kV	18.95	10.89	9.71	12.40	12.02	11.50	19.53	13.33	11.72	12.13	14.04	13.39
Cuilleen 110 kV	4.29	6.77	6.38	5.23	7.64	7.46	3.93	7.94	7.38	4.89	8.56	8.33
Cullenagh 110 kV	8.24	11.22	10.45	8.69	13.22	12.85	7.27	14.10	12.98	7.87	15.87	15.37
Cullenagh 220 kV	9.22	8.03	7.56	9.38	8.27	8.09	8.09	9.91	9.43	8.56	9.63	9.47
Cunghill 110 kV	3.21	4.41	4.20	3.69	4.28	4.21	3.24	6.20	5.72	3.82	5.27	5.15
Cushaling 110 kV	5.97	7.10	6.40	7.06	8.75	8.37	7.85	10.84	9.59	9.73	11.86	11.32
Dallow 110 kV	3.53	4.85	4.66	4.66	3.04	3.02	3.42	5.57	5.28	4.62	3.33	3.29
Dalton 110 kV	3.00	3.58	3.42	4.10	3.15	3.11	3.31	5.04	4.54	4.66	3.79	3.69
Dardistown 110 kV	15.09	9.73	8.85	12.05	11.21	10.80	15.64	12.49	11.09	11.97	13.66	13.05
Derrybrien 110 kV	2.64	3.63	3.53	3.69	3.55	3.52	3.05	5.01	4.40	4.48	4.43	4.26
Derryiron 110 kV	5.59	4.36	4.17	6.58	5.06	4.98	6.47	8.27	7.65	8.04	8.11	7.90
Doon 110 kV	4.11	6.22	5.82	4.57	5.30	5.20	4.21	7.84	7.20	4.69	6.06	5.92
Dromada 110 kV	5.48	6.90	6.49	4.63	7.39	7.22	5.70	11.36	9.86	4.53	10.20	9.75

Table E-2 Ireland Short Circuit Currents for Maximum and Minimum Demand in 2016

Station	Summer						Winter					
	Three phase			Single phase			Three phase			Single phase		
	X/R Ratio	Ik'' [kA]	Ik'' [kA]	X/R Ratio	Ik'' [kA]	Ik'' [kA]	X/R Ratio	Ik'' [kA]	Ik'' [kA]	X/R Ratio	Ik'' [kA]	Ik'' [kA]
Drumkeen 110 kV	3.40	4.57	4.33	4.14	4.69	4.60	4.03	8.29	6.97	5.03	7.00	6.64
Drumline 110 kV	3.55	6.35	5.96	4.61	5.79	5.68	3.29	8.52	7.86	4.57	6.96	6.80
Drybridge 110 kV	5.83	11.75	10.83	6.69	10.14	9.89	5.27	14.50	13.35	6.35	11.65	11.39
Dundalk 110 kV	3.81	7.75	7.32	4.75	7.27	7.14	3.44	9.18	8.52	4.48	8.16	7.98
Dunfirth 110 kV	4.88	4.86	4.66	6.38	4.16	4.11	4.64	6.58	6.34	6.34	5.04	4.99
Dungarvan 110 kV	6.06	5.50	5.26	7.74	4.75	4.69	5.82	6.82	6.35	7.71	5.49	5.38
Dunmanway 110 kV	3.45	4.89	4.56	4.43	4.55	4.45	3.33	6.92	6.24	4.54	5.56	5.40
Dunstown 220 kV	12.85	15.00	13.33	11.79	14.83	14.22	10.82	20.14	18.45	10.41	18.32	17.81
Dunstown 400 kV	21.71	4.40	4.15	15.25	3.86	3.79	20.64	5.67	5.46	14.43	4.71	4.66
Ennis 110 kV	3.87	7.44	6.94	4.92	7.33	7.16	4.47	10.95	9.79	5.94	9.54	9.23
Fassaroe East 110 kV	4.84	8.31	7.73	5.15	6.03	5.92	6.21	6.59	6.09	6.21	4.98	4.88
Fassaroe West 110 kV	4.97	8.50	7.90	5.24	6.24	6.12	6.39	6.70	6.19	6.34	5.11	5.00
Finglas 220 kV	14.56	14.63	12.93	14.11	18.67	17.65	17.11	25.22	22.09	15.39	29.40	27.81
Finglas A 110 kV	27.14	11.05	9.98	25.91	12.57	12.08	35.28	14.63	12.83	30.58	15.64	14.89
Finglas B 110 kV	27.16	10.71	9.94	25.82	13.57	13.13	36.34	14.71	13.33	31.49	17.87	17.14
Flagford 110 kV	4.74	9.80	9.09	5.49	11.92	11.55	4.42	13.44	12.09	5.32	15.43	14.79
Flagford 220 kV	7.27	6.07	5.71	9.20	5.90	5.78	7.41	8.02	7.59	9.72	7.10	6.99
Francis Street A 110 kV	11.34	10.04	9.27	5.82	12.34	11.92	10.48	13.84	12.53	5.04	16.01	15.39
Francis Street B 110 kV	13.05	11.01	10.20	6.91	13.46	13.03	12.78	13.48	12.40	6.49	15.98	15.44
Galway 110 kV	4.87	9.53	8.81	5.46	10.60	10.29	5.07	14.22	12.86	4.50	16.06	15.44
Garrow 110 kV	4.66	4.25	4.05	4.60	4.93	4.84	9.52	11.06	9.94	9.70	11.90	11.43
Garvagh 110 kV	3.94	4.78	4.59	5.11	4.68	4.62	4.35	6.78	6.02	5.89	5.83	5.63
Gilra 110 kV	3.26	5.68	5.40	4.07	4.51	4.45	3.01	6.85	6.44	3.95	5.08	5.00
Glanagow 220 kV	12.00	9.27	8.18	12.18	11.98	11.31	13.83	18.16	16.06	13.29	20.75	19.74
Glanlee 110 kV	5.69	3.98	3.81	6.25	4.87	4.79	6.05	7.27	6.37	6.09	8.05	7.64
Glasmore A 110 kV	4.98	6.16	5.74	5.35	4.51	4.43	4.72	7.55	6.80	5.22	5.02	4.90
Glenlara A 110 kV	2.99	2.52	2.41	4.36	2.20	2.17	6.08	9.83	8.93	7.35	7.19	7.02
Glenlara B 110 kV	2.99	2.52	2.41	4.36	2.20	2.17	6.08	9.83	8.93	7.35	7.19	7.02
Glenree 110 kV	3.26	3.65	3.44	3.96	3.33	3.27	3.74	5.57	5.14	4.50	4.24	4.16
Golagh 110 kV	3.17	3.56	3.42	4.00	2.68	2.65	4.02	7.83	6.62	4.60	6.29	5.99

Table E-2 Ireland Short Circuit Currents for Maximum and Minimum Demand in 2016

Station	Summer						Winter					
	Three phase			Single phase			Three phase			Single phase		
	X/R Ratio	Ik'' [kA]	Ik'' [kA]	X/R Ratio	Ik'' [kA]	Ik'' [kA]	X/R Ratio	Ik'' [kA]	Ik'' [kA]	X/R Ratio	Ik'' [kA]	Ik'' [kA]
Gorman 110 kV	6.86	12.56	11.50	7.74	14.00	13.54	6.11	15.59	14.30	7.15	16.56	16.05
Gorman 220 kV	9.66	9.77	8.98	10.31	8.41	8.20	8.50	12.22	11.56	9.61	9.70	9.55
Gortawee 110 kV	4.41	5.48	5.13	5.80	4.72	4.63	4.43	6.67	6.18	6.04	5.19	5.09
Grange 110 kV	12.91	9.81	8.91	4.62	10.35	9.99	12.98	12.65	11.19	4.28	12.42	11.90
Grange Castle 110 kV	17.95	11.04	9.81	13.09	12.48	11.91	18.34	13.55	11.86	12.86	14.64	13.92
Great Island 110 kV	7.95	11.19	10.48	8.71	14.61	14.19	6.92	13.82	12.71	7.73	17.49	16.86
Great Island 220 kV	12.43	10.44	9.74	13.81	12.60	12.24	10.55	12.60	11.87	11.99	14.53	14.18
Griffinrath A 110 kV	7.58	8.97	8.45	7.79	9.30	9.11	6.77	11.21	10.58	7.21	11.02	10.81
Griffinrath B 110 kV	8.86	9.56	8.98	8.85	10.34	10.10	7.93	12.07	11.36	8.16	12.40	12.14
Harolds 110 kV	11.51	10.07	9.29	5.51	12.31	11.90	10.67	13.87	12.57	4.76	15.95	15.33
Heuston 110 kV	14.05	11.21	10.37	8.28	13.83	13.38	13.88	13.76	12.64	7.83	16.49	15.92
Huntstown A 220 kV	13.95	14.15	12.55	12.68	18.07	17.11	16.36	24.29	21.36	13.20	28.34	26.86
Huntstown B 220 kV	15.01	14.47	12.86	11.65	17.97	17.06	15.18	22.81	20.39	10.55	26.13	24.96
Ikerrin 110 kV	5.19	4.13	3.92	6.00	3.18	3.14	5.75	5.62	5.09	6.45	3.81	3.72
Inchicore 220 kV	14.44	16.87	14.50	11.27	20.91	19.54	13.94	26.60	23.04	9.98	30.42	28.67
Inchicore A 110 kV	26.95	12.24	11.27	24.38	15.45	14.90	30.48	15.26	13.93	26.23	18.73	18.02
Inchicore B 110 kV	38.31	12.42	11.00	31.82	15.83	15.00	49.09	15.54	13.55	36.55	19.26	18.15
Inniscarra 110 kV	5.13	7.39	6.86	6.19	7.29	7.10	4.74	10.76	9.94	6.14	9.17	8.95
Irishtown 220 kV	15.14	16.00	13.83	12.46	20.15	18.86	15.40	24.86	21.62	11.55	28.98	27.33
Kellis 110 kV	6.39	7.78	7.39	7.30	9.36	9.17	6.21	9.85	9.09	7.22	11.32	10.97
Kellis 220 kV	8.22	7.10	6.74	9.90	6.24	6.14	7.68	8.49	8.13	9.55	7.06	6.97
Kilbarry 110 kV	7.47	13.04	11.51	8.04	14.66	13.95	7.17	23.63	20.43	8.02	22.35	21.28
Kildonan 110 kV	9.10	15.75	14.30	6.51	14.06	13.64	6.89	17.31	16.12	6.00	15.81	15.46
Kilkenny 110 kV	3.03	4.66	4.49	3.44	5.73	5.64	2.97	5.58	5.16	3.42	6.59	6.38
Kill Hill 110 kV	4.52	4.93	4.65	5.44	4.78	4.69	5.50	7.38	6.55	6.57	6.19	5.98
Killonan 110 kV	6.69	12.82	11.45	7.76	14.85	14.19	6.69	21.33	18.97	8.22	21.73	20.85
Killonan 220 kV	7.72	7.34	6.73	9.50	7.63	7.39	7.73	11.62	10.86	10.20	10.42	10.20
Killoteran 110 kV	6.36	9.76	9.15	5.42	10.90	10.63	5.65	12.02	11.05	4.95	12.80	12.41
Kilmahud 110 kV	17.53	10.95	9.74	12.42	12.37	11.81	17.84	13.41	11.75	12.15	14.49	13.78
Kilmore 110 kV	14.62	10.01	9.08	9.65	11.34	10.92	15.07	12.96	11.44	9.35	13.85	13.21

Table E-2 Ireland Short Circuit Currents for Maximum and Minimum Demand in 2016

Station	Summer						Winter					
	Three phase			Single phase			Three phase			Single phase		
	X/R Ratio	Ik'' [kA]	Ik'' [kA]	X/R Ratio	Ik'' [kA]	Ik'' [kA]	X/R Ratio	Ik'' [kA]	Ik'' [kA]	X/R Ratio	Ik'' [kA]	Ik'' [kA]
Kilteel 110 kV	4.60	6.79	6.42	5.60	6.34	6.23	4.34	8.40	7.84	5.46	7.24	7.09
Kinnegad 110 kV	5.20	4.16	3.98	6.43	4.21	4.14	4.89	8.17	7.68	6.40	7.09	6.96
Knockearagh 110 kV	5.46	4.65	4.40	6.72	4.55	4.47	5.27	6.27	5.78	7.25	5.07	4.95
Knocknagoshel 110 kV	4.91	5.62	5.33	5.28	6.64	6.50	5.00	9.50	8.09	5.58	9.72	9.17
Knockraha A 110 kV	8.74	14.04	12.40	9.34	15.20	14.50	8.22	24.39	21.53	9.13	22.33	21.45
Knockraha A 220 kV	10.16	9.51	8.44	10.56	11.40	10.83	10.95	19.64	17.45	11.08	19.78	18.96
Knockraha B 110 kV	8.74	14.04	12.40	9.34	15.20	14.50	8.22	24.39	21.53	9.13	22.33	21.45
Knockraha B 220 kV	10.16	9.51	8.44	10.56	11.40	10.83	10.95	19.64	17.45	11.08	19.78	18.96
Knockumber 110 kV	3.92	7.58	7.11	4.70	5.78	5.68	3.59	8.73	8.20	4.51	6.30	6.20
Lanesboro 110 kV	4.17	9.26	8.49	5.15	10.13	9.81	3.81	12.05	10.83	5.00	11.96	11.53
Letterkenny 110 kV	3.73	5.31	4.98	4.39	6.15	5.99	4.38	9.87	8.18	5.41	9.58	8.97
Liberty A 110 kV	6.34	11.61	10.36	5.51	13.68	13.05	5.78	19.93	17.50	4.87	20.46	19.52
Liberty B 110 kV	6.26	11.60	10.35	5.36	13.66	13.03	5.66	19.90	17.48	4.70	20.40	19.46
Limerick 110 kV	5.52	11.49	10.29	6.22	11.69	11.24	5.11	18.05	16.09	6.10	15.71	15.17
Lisdrum 110 kV	2.88	4.58	4.40	4.14	4.11	4.06	2.72	5.27	4.92	4.05	4.41	4.32
Lisheen 110 kV	3.88	3.25	3.06	3.89	4.87	4.72	5.00	5.19	4.46	5.01	7.79	7.19
Lodgewood 110 kV	8.51	7.22	6.92	8.91	9.08	8.92	8.86	9.33	8.71	9.07	10.99	10.68
Lodgewood 220 kV	8.99	6.60	6.27	10.15	6.52	6.40	8.77	8.06	7.67	9.95	7.48	7.36
Longpoint 220 kV	8.75	7.76	6.99	9.12	10.12	9.65	12.27	17.93	15.93	12.09	19.87	18.96
Louth 220 kV	11.06	13.36	11.86	11.90	15.81	15.04	9.30	18.70	17.20	10.54	20.31	19.69
Louth A 110 kV	7.39	11.07	10.31	8.36	13.47	13.08	6.59	13.54	12.57	7.68	15.94	15.47
Louth B 110 kV	8.02	11.93	11.05	8.81	14.87	14.39	7.04	14.66	13.59	7.93	17.70	17.16
Macetown 110 kV	7.85	15.44	14.01	7.58	15.49	14.98	7.11	18.08	16.76	7.15	17.64	17.20
Macroon 110 kV	6.65	9.33	8.49	7.21	9.26	8.96	6.37	15.08	13.59	7.16	12.55	12.18
Mallow 110 kV	5.32	5.59	5.25	6.96	4.89	4.80	4.99	7.89	7.44	6.84	6.37	6.26
Marina 110 kV	7.27	12.53	11.09	8.02	14.94	14.19	7.19	22.65	19.58	8.33	23.23	22.03
Maynooth A 110 kV	11.79	10.96	10.22	12.32	13.61	13.21	10.61	14.21	13.28	11.32	17.01	16.55
Maynooth A 220 kV	11.27	14.07	12.50	10.67	13.87	13.31	9.64	19.26	17.59	9.54	17.32	16.83
Maynooth B 110 kV	8.81	14.74	13.38	10.10	14.67	14.19	7.86	18.32	17.10	9.41	17.26	16.88
Maynooth B 220 kV	11.74	15.63	13.78	10.89	15.54	14.86	9.71	22.46	20.40	9.52	20.10	19.50

Table E-2 Ireland Short Circuit Currents for Maximum and Minimum Demand in 2016

Station	Summer						Winter					
	Three phase			Single phase			Three phase			Single phase		
	X/R Ratio	Ik'' [kA]	Ik'' [kA]	X/R Ratio	Ik'' [kA]	Ik'' [kA]	X/R Ratio	Ik'' [kA]	Ik'' [kA]	X/R Ratio	Ik'' [kA]	Ik'' [kA]
McDermott 110 kV	15.49	9.91	9.23	6.42	11.80	11.46	16.55	13.47	12.23	5.82	15.17	14.60
Meath Hill 110 kV	4.13	7.85	7.41	5.23	6.72	6.61	3.82	9.48	8.78	5.06	7.59	7.43
Meentycat 110 kV	3.18	3.94	3.76	4.05	4.00	3.93	3.74	6.80	5.82	5.03	5.65	5.39
Midleton 110 kV	4.15	8.28	7.62	5.00	7.11	6.94	3.47	11.48	10.67	4.62	8.65	8.48
Milltown A 110 kV	15.11	10.74	9.87	7.51	13.37	12.89	14.93	15.07	13.59	6.59	17.68	16.95
Milltown B 110 kV	9.19	10.02	9.33	4.30	12.04	11.69	8.75	12.15	11.21	4.00	14.12	13.67
Misery Hill 110 kV	13.77	10.52	9.69	8.20	13.19	12.73	13.27	14.70	13.26	7.29	17.43	16.70
Moneteen 110 kV	5.72	9.07	8.22	6.45	7.33	7.13	5.30	12.19	11.20	6.28	8.65	8.47
Moneypoint 110 kV	2.53	2.04	1.99	3.71	1.48	1.47	3.80	2.96	2.72	5.01	1.79	1.75
Moneypoint 220 kV	8.29	5.19	4.88	8.06	6.12	5.96	12.47	10.74	9.98	9.81	10.30	10.05
Moneypoint G1 400 kV	19.73	4.92	4.58	17.78	5.46	5.31	23.27	7.28	6.83	18.86	7.18	7.03
Moneypoint G2 400 kV	13.06	1.89	1.81	13.42	2.37	2.33	29.19	3.95	3.71	23.07	4.16	4.06
Moneypoint G3 400 kV	19.73	4.92	4.58	17.78	5.46	5.31	23.27	7.28	6.83	18.86	7.18	7.03
Monread 110 kV	4.31	6.66	6.29	5.14	6.81	6.67	4.03	8.19	7.66	4.96	7.83	7.66
Mount Lucas 110 kV	4.45	4.22	3.96	5.62	4.09	4.00	5.04	5.92	5.49	6.52	5.10	4.98
Moy 110 kV	3.47	3.70	3.44	4.18	4.28	4.16	4.97	6.31	5.66	6.19	6.28	6.05
Mullagharlin 110 kV	3.92	7.88	7.45	4.92	7.77	7.62	3.53	9.25	8.66	4.62	8.70	8.52
Mullingar 110 kV	2.81	4.06	3.90	3.86	4.23	4.17	3.49	7.39	6.93	4.89	6.74	6.61
Mulreavy 110 kV	-	-	-	-	-	-	4.57	8.66	7.08	5.46	8.60	8.00
Mungret A 110 kV	5.40	8.67	7.89	6.15	6.85	6.68	4.96	11.51	10.62	5.96	8.01	7.86
Mungret B 110 kV	5.39	8.69	7.90	6.14	6.86	6.68	4.95	11.53	10.64	5.95	8.02	7.87
Nangor 110 kV	15.76	10.80	9.61	10.49	12.17	11.63	15.80	13.19	11.59	10.15	14.23	13.55
Navan 110 kV	5.82	11.13	10.25	6.54	11.09	10.78	5.25	13.66	12.55	6.14	12.81	12.47
Nenagh 110 kV	2.71	3.23	3.08	3.82	1.93	1.91	2.66	4.00	3.68	3.87	2.08	2.05
Newbridge 110 kV	4.56	8.44	7.81	5.23	8.49	8.27	4.27	10.96	10.06	5.07	10.16	9.89
Newbury 110 kV	13.84	9.94	9.01	7.31	11.03	10.62	14.10	12.83	11.33	6.92	13.38	12.79
Nore 110 kV	2.97	4.43	4.27	3.47	5.54	5.45	2.91	5.26	4.88	3.45	6.34	6.15
North Kerry 220 kV	7.40	5.84	5.42	8.18	6.94	6.73	9.03	11.86	10.71	9.79	11.86	11.44
North Kerry A 110 kV	7.34	9.08	8.38	8.00	10.70	10.36	9.45	16.39	14.01	10.40	15.85	15.01
North Kerry B 110 kV	7.34	9.08	8.38	8.00	10.70	10.36	5.82	13.44	11.79	6.33	10.34	9.98

Table E-2 Ireland Short Circuit Currents for Maximum and Minimum Demand in 2016

Station	Summer						Winter					
	Three phase			Single phase			Three phase			Single phase		
	X/R Ratio	Ik'' [kA]	Ik'' [kA]	X/R Ratio	Ik'' [kA]	Ik'' [kA]	X/R Ratio	Ik'' [kA]	Ik'' [kA]	X/R Ratio	Ik'' [kA]	Ik'' [kA]
North Quays 110 kV	17.84	10.92	10.03	7.04	13.38	12.91	18.67	15.40	13.87	6.13	17.69	16.97
North Wall 220 kV	13.69	13.48	12.02	9.48	15.89	15.15	15.29	22.72	20.10	8.56	23.76	22.69
Oldcourt A 110 kV	4.37	8.31	7.66	4.77	6.90	6.74	3.64	11.60	10.83	4.38	8.40	8.25
Oldcourt B 110 kV	4.41	8.35	7.70	4.80	6.96	6.80	3.68	11.68	10.90	4.40	8.48	8.34
Oldstreet 220 kV	13.19	6.81	6.45	11.88	8.00	7.83	15.31	11.08	10.48	12.52	11.69	11.46
Oldstreet 400 kV	15.76	5.33	4.98	11.22	5.49	5.36	17.69	7.73	7.36	10.91	7.19	7.08
Oughtragh 110 kV	3.75	3.95	3.75	4.73	2.79	2.75	3.45	5.16	4.79	4.69	3.12	3.07
Pelletstown 110 kV	13.70	9.45	8.83	8.13	10.44	10.18	13.72	12.61	11.53	7.58	13.09	12.67
Platin 110 kV	5.26	10.95	10.15	5.83	8.56	8.38	4.69	13.13	12.23	5.51	9.59	9.42
Pollaphuca 110 kV	2.77	2.39	2.35	3.98	2.23	2.22	3.31	3.11	2.98	4.72	2.56	2.53
Poolbeg A 110 kV	23.94	11.38	10.43	20.70	14.57	14.02	28.55	16.12	14.51	22.31	19.62	18.76
Poolbeg A 220 kV	14.29	13.56	12.08	8.30	15.21	14.52	16.16	22.86	20.22	7.19	22.36	21.41
Poolbeg B 110 kV	23.92	11.37	10.42	20.69	14.56	14.01	28.51	16.10	14.49	22.29	19.60	18.74
Poolbeg B 220 kV	13.83	15.83	13.71	10.67	18.53	17.44	13.51	24.55	21.48	9.59	26.17	24.86
Poolbeg C 110 kV	19.63	11.11	10.19	8.10	13.65	13.16	21.41	15.75	14.17	7.15	18.15	17.39
Poppintree 110 kV	15.41	10.25	9.31	9.83	11.61	11.18	16.09	13.34	11.78	9.53	14.23	13.58
Portan 260 kV	23.68	8.16	7.65	87.27	2.90	2.87	24.28	11.13	10.70	107.66	3.12	3.11
Portan 400 kV	20.09	6.39	5.93	19.11	7.39	7.17	19.71	8.99	8.56	18.93	10.01	9.82
Portlaoise 110 kV	4.17	7.28	6.83	5.51	6.24	6.12	3.92	9.16	8.46	5.43	7.19	7.04
Pottery 110 kV	13.11	13.93	12.43	4.43	14.04	13.48	17.54	12.57	11.38	5.55	12.26	11.85
Prospect 220 kV	7.81	6.22	5.78	7.96	7.53	7.30	11.10	13.97	12.73	9.90	13.71	13.27
Raffeen 220 kV	11.09	9.02	7.99	11.12	11.68	11.04	12.12	18.92	16.70	11.56	21.39	20.33
Raffeen A 110 kV	6.58	10.81	9.75	7.23	13.22	12.66	5.63	16.82	15.30	6.55	18.89	18.20
Raffeen B 110 kV	8.90	10.49	9.46	9.58	12.86	12.31	8.68	16.31	14.72	9.61	18.32	17.60
Rathkeale 110 kV	3.60	5.65	5.34	4.73	4.90	4.82	3.42	7.77	7.22	4.80	5.93	5.82
Ratrussan 110 kV	3.13	5.69	5.44	3.91	6.51	6.40	3.61	7.94	6.79	4.73	8.24	7.79
Reamore 110 kV	4.35	5.65	5.32	3.51	5.36	5.26	4.00	8.41	7.58	3.24	6.69	6.50
Richmond A 110 kV	3.30	6.38	5.98	4.37	5.97	5.85	3.05	7.82	7.20	4.25	6.81	6.64
Richmond B 110 kV	3.30	6.38	5.98	4.37	5.97	5.85	3.05	7.82	7.20	4.25	6.81	6.64
Rinawade 110 kV	5.18	9.32	8.72	6.07	7.06	6.94	4.79	11.34	10.82	5.86	8.01	7.92

Table E-2 Ireland Short Circuit Currents for Maximum and Minimum Demand in 2016

Station	Summer						Winter					
	Three phase			Single phase			Three phase			Single phase		
	X/R Ratio	Ik'' [kA]	Ik'' [kA]	X/R Ratio	Ik'' [kA]	Ik'' [kA]	X/R Ratio	Ik'' [kA]	Ik'' [kA]	X/R Ratio	Ik'' [kA]	Ik'' [kA]
Ringaskiddy 110 kV	6.52	9.08	8.29	6.67	9.40	9.10	5.75	13.28	12.20	6.16	12.27	11.94
Ringsend 110 kV	23.88	11.38	10.42	21.37	14.59	14.03	29.07	16.29	14.60	23.64	19.81	18.91
Ryebrook 110 kV	5.72	12.86	11.58	6.57	11.69	11.31	5.20	15.02	13.90	6.21	13.02	12.72
Salthill 110 kV	4.90	8.82	8.18	4.81	9.82	9.54	5.09	12.82	11.65	3.83	14.29	13.77
Screeb 110 kV	3.49	2.34	2.24	4.46	1.36	1.34	3.55	2.74	2.54	2.79	2.68	2.61
Seal Rock A 110 kV	8.85	8.61	7.56	10.54	9.62	9.14	7.98	10.11	9.09	9.78	10.61	10.20
Seal Rock B 110 kV	8.88	8.62	7.56	10.56	9.62	9.14	8.01	10.12	9.09	9.80	10.61	10.21
Shankill 110 kV	3.49	6.89	6.50	4.47	6.54	6.42	3.49	9.10	8.02	4.67	7.86	7.57
Shannonbridge 110 kV	7.02	14.36	12.80	8.54	16.44	15.71	5.96	17.38	15.64	7.51	18.96	18.22
Shannonbridge 220 kV	8.14	6.28	5.92	10.48	5.63	5.53	7.19	7.59	7.32	9.75	6.40	6.34
Shellybanks A 220 kV	14.06	13.53	12.06	8.23	16.73	15.91	15.85	22.82	20.19	7.00	25.57	24.34
Shellybanks B 220 kV	14.42	15.43	13.40	10.93	19.22	18.04	14.81	23.95	20.91	9.94	27.52	26.01
Shelton Abbey 110 kV	7.58	6.80	6.49	7.60	7.30	7.18	7.56	8.26	7.70	7.61	8.42	8.22
Singland 110 kV	6.23	10.93	9.89	7.14	11.54	11.12	6.45	17.24	15.55	7.63	15.70	15.20
Sligo 110 kV	3.91	7.11	6.67	4.51	7.17	7.01	3.69	10.40	9.31	4.48	9.17	8.86
Somerset 110 kV	3.15	6.94	6.57	4.09	4.61	4.55	2.90	8.12	7.68	3.96	5.10	5.04
Sorne Hill 110 kV	2.68	2.17	2.10	3.31	2.53	2.50	3.41	3.62	3.18	4.31	3.62	3.46
Srananagh 110 kV	4.67	8.01	7.48	5.37	9.17	8.93	4.66	12.20	10.81	5.60	12.52	11.99
Srananagh 220 kV	6.70	3.89	3.72	8.77	3.33	3.29	7.41	4.99	4.75	9.73	3.88	3.83
Stevenstown 110 kV	4.80	5.20	4.92	5.16	3.58	3.53	4.57	6.11	5.66	5.05	3.91	3.84
Stratford 110 kV	3.17	3.65	3.54	4.14	2.97	2.94	3.36	4.57	4.30	4.37	3.35	3.30
Suir 110 kV	3.90	6.52	6.10	4.60	7.79	7.58	4.19	8.89	8.10	5.12	9.77	9.43
Taney 110 kV	7.15	11.53	10.48	2.65	11.13	10.78	8.69	10.69	9.81	3.18	10.15	9.86
Tarbert 110 kV	6.84	8.95	8.29	8.15	9.59	9.33	7.96	15.91	14.24	10.04	13.64	13.19
Tarbert 220 kV	7.91	6.69	6.16	8.63	8.82	8.49	13.36	16.84	14.93	14.58	18.74	17.86
Tawnaghmore A 110 kV	3.16	3.03	2.85	4.00	3.25	3.17	4.47	5.09	4.65	5.83	4.53	4.41
Tawnaghmore B 110 kV	3.61	3.34	3.08	4.44	3.86	3.74	5.20	5.42	4.91	6.67	5.41	5.23
Thornsberry 110 kV	3.61	2.73	2.63	4.54	2.95	2.91	3.47	4.22	3.94	4.71	4.07	3.98
Thurles 110 kV	4.90	4.20	3.94	5.29	4.84	4.72	6.10	6.58	5.67	6.40	6.76	6.40
Tipperary 110 kV	3.67	5.65	5.34	4.68	4.30	4.24	4.33	7.76	7.19	5.48	5.20	5.11

Table E-2 Ireland Short Circuit Currents for Maximum and Minimum Demand in 2016

Station	Summer						Winter					
	Three phase			Single phase			Three phase			Single phase		
	X/R Ratio	Ik'' [kA]	Ik'' [kA]	X/R Ratio	Ik'' [kA]	Ik'' [kA]	X/R Ratio	Ik'' [kA]	Ik'' [kA]	X/R Ratio	Ik'' [kA]	Ik'' [kA]
Tonroe 110 kV	2.69	3.03	2.94	3.75	1.91	1.90	2.70	3.67	3.39	3.82	2.09	2.06
Trabeg 110 kV	7.28	12.47	11.03	7.89	14.68	13.96	7.12	22.31	19.33	8.02	22.59	21.46
Tralee 110 kV	4.86	7.05	6.56	5.71	6.70	6.54	4.45	11.58	10.18	5.72	8.75	8.46
Trien A 110 kV	6.59	8.29	7.68	6.97	9.56	9.28	7.00	15.99	13.46	7.35	14.85	14.02
Trien B 110 kV	6.59	8.29	7.68	6.97	9.56	9.28	7.00	15.99	13.46	7.35	14.85	14.02
Trillick 110 kV	2.72	2.33	2.25	3.39	2.55	2.52	3.52	3.97	3.45	4.42	3.61	3.45
Trinity 110 kV	-	-	-	-	-	-	11.64	14.27	12.90	6.07	16.75	16.07
Tullabrack 110 kV	2.55	2.16	2.10	3.72	1.60	1.59	3.91	3.16	2.90	5.13	1.94	1.91
Turlough 220 kV	12.18	10.93	9.85	13.39	9.98	9.65	10.58	12.90	11.95	12.21	11.08	10.83
Tynagh 220 kV	10.45	6.58	6.23	11.47	8.23	8.04	15.05	12.57	11.63	16.70	13.54	13.15
Uggool 110 kV	-	-	-	-	-	-	6.19	8.35	7.85	5.73	10.44	10.17
Waterford 110 kV	7.55	10.61	9.90	7.65	11.96	11.65	6.65	13.24	12.10	6.95	14.23	13.77
West Galway A 110 kV	-	-	-	-	-	-	3.90	5.27	4.95	2.67	3.99	3.92
West Galway B 110 kV	-	-	-	-	-	-	6.10	8.72	8.18	5.33	10.84	10.54
Wexford 110 kV	3.96	5.64	5.40	5.07	5.26	5.18	4.06	7.19	6.45	5.33	6.13	5.94
Whitegate 110 kV	4.88	7.85	7.26	5.51	8.43	8.19	4.28	10.80	10.15	5.12	10.61	10.39
Wolfe Tone 110 kV	13.99	9.73	9.07	5.88	11.46	11.14	14.40	13.15	11.96	5.31	14.64	14.11
Woodhouse 110 kV	6.04	5.42	5.19	7.30	4.20	4.15	5.86	6.76	6.33	7.29	4.80	4.73
Woodland 220 kV	14.29	15.82	14.05	13.66	17.87	17.04	12.39	23.97	21.76	12.27	24.88	24.02
Woodland 400 kV	21.30	6.41	5.95	20.54	7.42	7.20	21.41	9.04	8.60	20.79	10.08	9.89
Barnakyle 110 kV	2.88	4.58	4.40	4.14	4.11	4.06	2.72	5.27	4.92	4.05	4.41	4.32
Cloghboola 110 kV	4.91	5.62	5.33	5.28	6.64	6.50	5.00	9.50	8.09	5.58	9.72	9.17
Knockanure 110 kV	7.34	9.08	8.38	8.00	10.70	10.36	5.82	13.44	11.79	6.33	10.34	9.98
Knockanure 220 kV	7.40	5.84	5.42	8.18	6.94	6.73	9.03	11.86	10.71	9.79	11.86	11.44
Knockranny 110 kV	-	-	-	-	-	-	6.10	8.72	8.18	5.33	10.84	10.54
North Mayo 110 kV	2.96	3.28	3.10	3.77	3.40	3.33	3.94	4.91	4.47	5.16	4.57	4.44
Sliabh Bawn 110 kV	3.18	5.78	5.47	4.13	5.84	5.73	3.49	10.39	9.42	4.61	9.12	8.86

Table E-3 Ireland Short Circuit Currents for Maximum and Minimum Demand in 2019

Station	Summer						Winter					
	Three phase			Single phase			Three phase			Single phase		
	X/R Ratio	Ik'' [kA]	Ik'' [kA]	X/R Ratio	Ik'' [kA]	Ik'' [kA]	X/R Ratio	Ik'' [kA]	Ik'' [kA]	X/R Ratio	Ik'' [kA]	Ik'' [kA]
Adamstown 110 kV	13.83	11.10	9.69	8.74	12.25	11.62	11.64	13.13	11.78	6.22	15.39	14.72
Agannygal 110 kV	2.78	4.92	4.78	3.86	4.17	4.13	2.95	6.44	5.79	4.23	4.91	4.77
Aghada 110 kV	5.13	8.37	7.94	6.13	9.76	9.56	4.57	9.97	9.48	5.63	11.22	11.00
Aghada A 220 kV	12.11	11.91	10.76	13.20	14.70	14.06	12.02	18.78	16.77	13.28	20.95	20.03
Aghada B 220 kV	13.08	11.84	10.66	11.94	14.64	13.99	12.91	18.04	16.16	11.18	20.35	19.47
Aghada C 220 kV	11.81	11.62	10.52	12.13	14.35	13.74	11.66	18.16	16.27	11.85	20.34	19.47
Aghada D 220 kV	11.81	11.62	10.52	12.13	14.35	13.74	11.66	18.16	16.27	11.85	20.34	19.47
Ahane 110 kV	5.57	10.94	10.24	6.09	9.45	9.27	5.02	15.25	14.07	5.83	11.38	11.15
Anner 110 kV	4.05	5.95	5.66	4.55	4.83	4.76	3.98	7.23	6.71	4.55	5.37	5.27
Ardnacrusha 110 kV	6.31	11.88	11.02	7.51	13.24	12.87	6.53	18.62	16.70	8.22	18.06	17.40
Ardnagappary 110 kV	2.76	1.82	1.78	3.92	1.18	1.17	2.89	2.49	2.27	4.22	1.32	1.30
Arigna 110 kV	4.41	6.15	5.89	5.44	5.10	5.04	4.66	8.51	7.76	5.82	6.16	6.02
Arklow 110 kV	10.30	7.54	7.21	11.09	9.35	9.18	10.64	9.70	9.01	11.49	11.50	11.16
Arklow 220 kV	9.06	6.90	6.54	10.49	6.59	6.47	8.91	8.56	8.13	10.45	7.68	7.56
Artane 110 kV	13.16	9.62	9.03	6.31	11.73	11.42	13.36	12.37	11.22	5.92	14.48	13.91
Arva 110 kV	3.86	7.94	7.51	4.95	6.43	6.33	3.85	10.44	9.46	5.13	7.53	7.34
Athea 110 kV	11.05	6.92	6.70	10.88	7.78	7.68	13.32	11.62	9.92	12.66	11.28	10.67
Athlone 110 kV	4.40	7.24	6.85	5.17	7.99	7.82	4.08	8.44	7.84	4.88	8.86	8.63
Athy 110 kV	3.23	5.61	5.41	4.36	4.73	4.68	4.67	7.87	7.51	5.80	6.38	6.29
Aughinish 110 kV	9.08	9.71	8.65	11.03	10.79	10.32	8.08	10.82	9.75	10.07	11.53	11.09
Ballybeg 110 kV	9.71	5.93	5.70	9.94	7.07	6.96	9.83	7.14	6.77	10.05	8.25	8.08
Ballydine 110 kV	4.08	6.62	6.32	3.87	5.56	5.49	3.93	7.93	7.42	3.79	6.17	6.06
Ballylickey 110 kV	2.83	3.02	2.93	3.90	1.93	1.92	2.94	3.80	3.57	4.05	2.10	2.07
Ballynahulla 110 kV	11.84	7.66	7.37	11.61	8.41	8.30	14.42	12.47	11.16	12.94	11.49	11.08
Ballynahulla 220 kV	7.04	6.97	6.59	7.31	8.10	7.92	7.44	11.84	10.88	7.91	11.51	11.18
Ballyragget 110 kV	-	-	-	-	-	-	4.87	7.15	6.78	5.86	5.25	5.18
Ballyvouskill 110 kV	11.78	7.99	7.66	11.88	9.40	9.24	13.47	12.54	11.26	12.99	13.07	12.57
Ballyvouskill 220 kV	6.76	7.57	7.11	7.38	9.37	9.12	6.85	12.88	11.74	7.81	14.08	13.59
Ballywater 110 kV	4.61	4.91	4.77	3.30	5.21	5.16	4.62	6.21	5.85	3.18	6.10	5.98
Baltrasna 110 kV	6.33	9.61	9.09	7.43	7.56	7.45	5.87	11.36	10.81	7.17	8.44	8.34

Table E-3 Ireland Short Circuit Currents for Maximum and Minimum Demand in 2019

Station	Summer						Winter					
	Three phase			Single phase			Three phase			Single phase		
	X/R Ratio	Ik'' [kA]	Ik'' [kA]	X/R Ratio	Ik'' [kA]	Ik'' [kA]	X/R Ratio	Ik'' [kA]	Ik'' [kA]	X/R Ratio	Ik'' [kA]	Ik'' [kA]
Bancroft 110 kV	12.48	11.17	10.20	7.17	13.06	12.59	12.20	13.38	12.27	6.79	15.22	14.71
Bandon 110 kV	3.32	5.93	5.64	4.37	5.81	5.71	3.01	7.47	6.85	4.20	6.82	6.64
Banoge 110 kV	6.08	5.40	5.22	6.82	4.96	4.90	5.93	6.62	6.22	6.75	5.66	5.56
Barnadivane 110 kV	4.22	7.56	7.19	4.79	7.55	7.43	4.20	10.98	9.90	4.93	9.72	9.41
Barnahealy A 110 kV	6.07	11.25	10.51	6.60	11.78	11.50	5.30	14.55	13.50	6.05	14.13	13.78
Barnahealy B 110 kV	7.35	10.86	10.15	7.79	11.25	10.98	6.44	14.12	13.05	7.15	13.52	13.17
Baroda 110 kV	4.16	7.77	7.31	4.90	9.05	8.83	3.87	10.06	9.45	4.72	11.03	10.77
Barrymore 110 kV	3.93	7.06	6.76	5.40	5.71	5.64	3.73	8.90	8.38	5.42	6.57	6.47
Belcamp 110 kV	14.38	12.63	11.54	9.03	14.33	13.83	14.94	16.77	15.01	8.61	17.86	17.14
Belcamp 220 kV	11.84	13.47	12.07	10.25	16.86	16.07	11.69	22.26	19.65	9.44	25.45	24.18
Bellacorick 400 kV	-	-	-	-	-	-	17.30	6.84	6.19	16.17	9.23	8.81
Bellacorick A 110 kV	3.43	3.40	3.23	3.81	4.26	4.17	5.21	6.87	5.91	5.83	7.37	6.96
Bellacorick B 110 kV	-	-	-	-	-	-	13.73	2.37	2.23	14.51	2.89	2.81
Binbane 110 kV	3.18	3.41	3.29	4.30	3.40	3.36	3.61	5.90	5.20	5.39	4.72	4.55
Blackrock 110 kV	11.19	9.58	8.90	3.01	8.81	8.61	10.95	11.63	10.58	2.85	10.04	9.76
Blake 110 kV	4.08	7.40	7.02	5.06	5.22	5.16	3.85	9.22	8.76	4.98	5.94	5.87
Boggeragh 110 kV	6.12	6.45	6.21	7.22	7.00	6.90	6.54	9.04	8.35	7.82	8.77	8.54
Booltiagh 110 kV	6.31	6.36	6.14	7.87	5.57	5.51	6.87	9.19	8.37	8.73	6.82	6.65
Bracklone 110 kV	3.89	7.43	7.01	4.89	7.13	7.00	3.67	10.24	9.66	4.81	8.83	8.68
Brinny A 110 kV	3.19	5.35	5.11	4.22	4.83	4.77	2.91	6.58	6.10	4.07	5.52	5.41
Brinny B 110 kV	3.18	5.37	5.13	4.22	4.86	4.80	2.90	6.61	6.12	4.07	5.57	5.44
Butlerstown 110 kV	6.08	9.41	8.96	5.76	9.71	9.55	5.40	11.56	10.74	5.31	11.28	11.00
Cabra 110 kV	12.27	9.33	8.77	5.15	10.63	10.38	12.30	11.93	10.84	4.80	12.93	12.47
Cahir 110 kV	4.41	7.43	7.05	5.06	8.41	8.25	4.53	10.10	9.17	5.34	10.39	10.04
Carlow 110 kV	5.19	7.33	7.02	5.92	8.07	7.94	5.66	9.99	9.27	6.43	10.15	9.89
Carrickmines 220 kV	13.92	15.49	13.57	9.83	19.20	18.10	13.78	22.58	19.87	8.83	26.23	24.87
Carrickmines A 110 kV	27.76	10.94	10.09	23.14	12.11	11.74	31.46	13.46	12.16	24.47	14.25	13.73
Carrickmines B 110 kV	23.07	12.29	11.20	19.82	14.78	14.22	25.07	14.95	13.65	20.55	17.48	16.85
Carrick-on-Shannon 110 kV	4.39	9.64	9.04	5.08	10.65	10.39	4.30	13.48	12.21	5.09	13.94	13.45
Carrigadrohid 110 kV	6.95	10.90	10.20	7.11	10.98	10.73	6.72	16.14	14.65	6.96	13.99	13.59

Table E-3 Ireland Short Circuit Currents for Maximum and Minimum Demand in 2019

Station	Summer						Winter					
	Three phase			Single phase			Three phase			Single phase		
	X/R Ratio	Ik'' [kA]	Ik'' [kA]	X/R Ratio	Ik'' [kA]	Ik'' [kA]	X/R Ratio	Ik'' [kA]	Ik'' [kA]	X/R Ratio	Ik'' [kA]	Ik'' [kA]
Carrowbeg 110 kV	2.68	2.46	2.38	3.54	2.34	2.32	2.67	3.19	2.93	3.68	2.78	2.71
Cashla 110 kV	6.99	12.57	11.66	7.32	16.24	15.70	7.36	20.48	18.37	7.76	24.44	23.36
Cashla 220 kV	8.10	7.90	7.42	8.99	8.67	8.47	8.55	12.93	12.10	9.67	12.29	12.02
Castlebar 110 kV	3.12	4.13	3.93	3.69	4.64	4.55	3.35	6.41	5.61	4.12	6.37	6.08
Castledockrill 110 kV	6.80	6.42	6.20	4.88	7.82	7.71	6.85	8.27	7.78	4.67	9.43	9.20
Castlefarm A 110 kV	8.13	9.36	8.36	9.52	10.03	9.62	7.26	10.39	9.39	8.75	10.68	10.30
Castlefarm B 110 kV	8.14	9.34	8.35	9.53	10.02	9.60	7.27	10.37	9.37	8.76	10.66	10.29
Castleview 110 kV	4.33	10.94	10.25	4.81	8.42	8.27	3.71	14.07	13.09	4.48	9.62	9.45
Cathleen's Fall 110 kV	4.27	6.30	5.97	4.93	7.18	7.04	5.35	12.88	10.91	6.39	11.63	11.02
Cauteen 110 kV	5.40	6.44	6.18	6.30	4.57	4.53	5.81	8.97	8.30	6.66	5.32	5.24
Central 110 kV	14.34	10.04	9.31	7.91	10.89	10.59	14.34	12.21	11.11	7.61	12.67	12.25
Charleville 110 kV	4.56	5.62	5.38	5.96	5.27	5.20	4.76	7.68	6.96	6.51	6.48	6.30
Cherrywood 110 kV	10.47	9.33	8.68	7.71	9.61	9.37	10.18	11.20	10.25	7.45	11.04	10.72
City West 110 kV	6.20	7.33	6.69	6.13	5.54	5.40	5.95	8.53	7.72	5.99	6.13	5.98
Clahane 110 kV	4.24	6.30	6.03	5.20	5.96	5.88	4.06	8.23	7.60	5.14	6.93	6.77
Clashavoon 220 kV	7.96	7.77	7.29	8.65	9.40	9.15	7.52	13.09	11.93	8.49	13.96	13.48
Clashavoon A 110 kV	7.79	12.42	11.54	8.09	16.09	15.58	7.96	19.82	17.65	8.26	23.58	22.47
Clashavoon B 110 kV	7.79	12.42	11.54	8.09	16.09	15.58	7.96	19.82	17.65	8.26	23.58	22.47
Cliff 110 kV	4.02	5.14	4.92	4.97	5.29	5.21	4.62	9.17	8.10	6.02	7.50	7.24
Clogher 110 kV	3.90	5.24	5.00	4.27	6.05	5.94	5.25	11.76	9.42	5.57	11.21	10.37
Cloghran 110 kV	9.71	18.60	16.74	9.56	19.89	19.13	9.19	24.51	22.38	9.13	24.38	23.63
Clonkeen A 110 kV	5.72	5.49	5.29	6.78	4.13	4.09	5.49	6.62	6.28	6.71	4.54	4.48
Clonkeen B 110 kV	5.34	6.34	6.13	4.56	7.50	7.40	5.61	9.76	8.70	4.46	10.35	9.92
Cloon 110 kV	4.41	6.72	6.41	5.74	6.01	5.92	4.15	8.69	8.10	5.70	7.07	6.94
College Park 110 kV	9.46	17.82	16.12	6.69	20.01	19.24	8.93	23.29	21.36	6.13	24.69	23.91
Cookstown 110 kV	7.43	7.92	7.43	6.03	6.78	6.66	7.09	9.17	8.64	5.84	7.57	7.44
Coolroe 110 kV	5.37	8.86	8.38	6.60	8.56	8.40	4.91	11.75	10.90	6.42	10.28	10.05
Coomagearlahy 110 kV	5.30	5.13	4.99	5.71	6.13	6.06	5.97	7.97	6.97	6.48	8.69	8.25
Cordal 110 kV	9.98	6.73	6.51	8.33	6.52	6.45	11.56	10.79	9.70	8.43	8.47	8.22
Corderry 110 kV	4.02	6.30	6.03	4.98	6.23	6.14	4.33	9.64	8.51	5.59	8.15	7.85

Table E-3 Ireland Short Circuit Currents for Maximum and Minimum Demand in 2019

Station	Summer						Winter					
	Three phase			Single phase			Three phase			Single phase		
	X/R Ratio	Ik'' [kA]	Ik'' [kA]	X/R Ratio	Ik'' [kA]	Ik'' [kA]	X/R Ratio	Ik'' [kA]	Ik'' [kA]	X/R Ratio	Ik'' [kA]	Ik'' [kA]
Corduff 110 kV	10.43	19.87	17.78	11.47	22.59	21.62	9.97	26.58	24.13	11.22	28.37	27.38
Corduff 220 kV	14.43	15.21	13.50	13.38	18.94	17.97	15.04	25.32	22.22	13.08	28.66	27.18
Corkagh 110 kV	17.54	11.57	10.02	12.13	12.73	12.04	22.88	18.08	16.52	22.82	13.34	13.04
Corraclassy 110 kV	4.37	5.74	5.44	5.41	4.69	4.62	4.40	7.21	6.75	5.61	5.29	5.21
Cow Cross 110 kV	5.03	11.20	10.46	5.38	10.01	9.80	4.31	14.40	13.36	4.93	11.65	11.41
Crane 110 kV	6.39	6.97	6.69	6.47	7.63	7.51	6.54	9.26	8.48	6.50	9.29	9.01
Cromcastle A 110 kV	12.23	12.31	11.25	8.04	14.06	13.57	12.21	16.26	14.56	7.58	17.48	16.77
Cromcastle B 110 kV	12.23	12.31	11.25	8.04	14.06	13.57	12.21	16.26	14.56	7.58	17.48	16.77
Cronacarkfree 220 kV	-	-	-	-	-	-	6.05	6.80	5.63	5.68	7.01	6.53
Croy 110 kV	18.74	11.51	10.01	12.26	12.48	11.84	21.95	17.95	16.42	21.77	13.21	12.92
Cuilleen 110 kV	4.20	6.89	6.54	5.15	7.74	7.59	3.90	7.99	7.45	4.87	8.57	8.35
Cullenagh 110 kV	8.17	11.60	10.96	8.63	13.59	13.29	7.14	14.59	13.50	7.77	16.32	15.84
Cullenagh 220 kV	8.98	8.41	8.00	9.21	8.55	8.40	8.06	10.10	9.64	8.53	9.78	9.63
Cunghill 110 kV	3.26	4.51	4.32	3.74	4.39	4.33	3.21	6.49	6.00	3.81	5.50	5.38
Cushaling 110 kV	5.67	8.53	7.76	6.83	10.22	9.83	6.90	13.46	12.12	8.78	14.10	13.57
Dallow 110 kV	3.50	4.92	4.75	4.63	3.08	3.06	3.46	5.75	5.44	4.65	3.39	3.35
Dalton 110 kV	3.06	3.69	3.55	4.10	3.25	3.21	3.24	5.24	4.74	4.54	3.95	3.85
Dardistown 110 kV	13.52	12.19	11.15	10.54	14.16	13.67	13.84	16.07	14.41	10.27	17.64	16.92
Derrybrien 110 kV	2.63	3.86	3.77	3.73	3.70	3.68	2.99	5.18	4.57	4.43	4.52	4.35
Derryiron 110 kV	4.92	7.18	6.84	6.05	7.74	7.60	5.76	10.61	9.91	7.33	10.06	9.84
Doon 110 kV	4.35	6.47	6.15	4.74	5.47	5.39	4.31	8.00	7.38	4.75	6.14	6.01
Dromada 110 kV	7.92	6.63	6.43	5.60	7.23	7.15	7.95	10.95	9.38	5.09	10.23	9.72
Drumkeen 110 kV	3.52	4.75	4.53	4.19	4.97	4.89	3.88	8.93	7.53	4.93	7.37	7.01
Drumline 110 kV	3.56	7.21	6.87	4.71	6.28	6.19	3.22	9.46	8.75	4.59	7.34	7.18
Drybridge 110 kV	5.84	12.19	11.32	6.71	10.35	10.14	5.17	15.15	13.99	6.30	11.98	11.73
Dundalk 110 kV	3.76	7.89	7.50	4.72	7.35	7.24	3.38	9.55	8.88	4.44	8.40	8.22
Dunfirth 110 kV	4.70	5.88	5.65	6.31	4.70	4.65	4.54	6.84	6.62	6.27	5.16	5.11
Dungarvan 110 kV	5.98	5.71	5.53	7.71	4.84	4.79	5.91	7.40	6.82	7.91	5.69	5.57
Dunmanway 110 kV	4.28	7.00	6.65	5.14	6.51	6.40	4.20	9.88	8.91	5.25	8.00	7.77
Dunstown 220 kV	12.65	15.97	14.25	12.29	18.52	17.67	10.87	21.93	20.08	10.83	24.12	23.32

Table E-3 Ireland Short Circuit Currents for Maximum and Minimum Demand in 2019

Station	Summer						Winter					
	Three phase			Single phase			Three phase			Single phase		
	X/R Ratio	Ik'' [kA]	Ik'' [kA]	X/R Ratio	Ik'' [kA]	Ik'' [kA]	X/R Ratio	Ik'' [kA]	Ik'' [kA]	X/R Ratio	Ik'' [kA]	Ik'' [kA]
Dunstown 400 kV	17.66	6.21	5.77	19.86	6.87	6.68	15.57	8.62	8.19	17.62	9.18	9.01
Ennis 110 kV	4.96	9.40	8.87	6.22	8.76	8.60	5.14	14.39	12.64	6.72	11.30	10.91
Fassaroe East 110 kV	5.35	7.42	6.99	5.43	5.74	5.65	5.06	8.62	8.10	5.28	6.37	6.27
Fassaroe West 110 kV	5.50	7.57	7.12	5.53	5.93	5.83	5.20	8.81	8.27	5.37	6.59	6.48
Finglas 220 kV	14.10	14.59	12.98	13.82	18.80	17.82	16.05	25.22	21.97	14.80	29.70	28.02
Finglas A 110 kV	20.01	13.45	12.24	17.17	15.50	14.93	23.81	18.25	16.18	18.44	19.68	18.81
Finglas B 110 kV	26.43	10.67	9.96	25.36	13.55	13.15	34.06	13.96	12.58	30.34	17.14	16.40
Flagford 110 kV	4.69	10.08	9.44	5.44	12.25	11.92	4.63	14.22	12.85	5.50	16.69	16.02
Flagford 220 kV	7.16	6.24	5.91	9.09	6.04	5.93	7.91	9.05	8.49	8.83	10.17	9.92
Flagford 400 kV	-	-	-	-	-	-	13.44	3.15	2.98	12.74	3.61	3.53
Francis Street A 110 kV	11.20	10.15	9.42	5.75	12.45	12.06	10.46	13.90	12.59	5.04	16.11	15.48
Francis Street B 110 kV	12.89	11.41	10.43	6.83	13.90	13.38	12.72	13.83	12.53	6.47	16.40	15.74
Galway 110 kV	4.89	9.78	9.15	4.49	12.14	11.81	5.25	15.72	14.02	4.53	17.72	16.95
Garrow 110 kV	8.93	7.69	7.38	9.17	9.10	8.95	9.81	12.06	10.82	9.87	12.68	12.18
Garvagh 110 kV	4.23	4.91	4.74	5.44	4.74	4.69	4.80	7.24	6.43	6.40	6.00	5.80
Gilra 110 kV	3.23	5.81	5.55	4.05	4.60	4.54	3.03	7.10	6.70	3.95	5.27	5.19
Glanagow 220 kV	13.68	12.30	11.03	13.54	15.28	14.56	13.33	18.69	16.69	12.89	21.20	20.25
Glanlee 110 kV	5.27	4.98	4.85	5.43	5.96	5.89	5.92	7.65	6.71	5.99	8.37	7.96
Glasmore A 110 kV	4.39	6.78	6.40	4.88	4.81	4.74	4.11	8.32	7.62	4.74	5.38	5.27
Glenlara A 110 kV	2.94	2.63	2.55	4.20	2.34	2.31	3.14	3.32	3.01	4.65	2.74	2.67
Glenlara B 110 kV	8.70	5.72	5.55	6.83	5.83	5.77	9.45	8.85	7.90	6.60	7.73	7.47
Glenree 110 kV	3.40	3.73	3.53	4.12	3.64	3.57	3.82	6.05	5.56	4.74	4.86	4.75
Golagh 110 kV	3.58	4.56	4.38	4.05	4.56	4.50	4.01	8.95	7.49	4.59	7.07	6.72
Gorman 110 kV	6.72	12.86	11.89	7.61	14.23	13.82	6.00	16.21	14.91	7.06	17.06	16.55
Gorman 220 kV	9.47	10.04	9.30	10.14	8.57	8.38	8.45	12.83	12.12	9.55	10.06	9.91
Gortawee 110 kV	4.44	5.60	5.28	5.85	4.78	4.70	4.49	6.88	6.40	6.12	5.33	5.23
Grange 110 kV	12.03	12.21	11.17	6.11	13.59	13.13	11.97	16.12	14.43	5.64	16.80	16.13
Grange Castle 110 kV	17.74	11.68	10.12	12.95	13.01	12.30	14.20	14.05	12.52	9.10	16.95	16.14
Great Island 110 kV	7.80	11.41	10.81	8.57	14.87	14.52	6.69	14.43	13.36	7.51	18.19	17.59
Great Island 220 kV	11.92	10.70	10.09	13.32	12.86	12.55	10.54	12.78	12.07	12.00	14.60	14.28

Table E-3 Ireland Short Circuit Currents for Maximum and Minimum Demand in 2019

Station	Summer						Winter					
	Three phase			Single phase			Three phase			Single phase		
	X/R Ratio	Ik'' [kA]	Ik'' [kA]	X/R Ratio	Ik'' [kA]	Ik'' [kA]	X/R Ratio	Ik'' [kA]	Ik'' [kA]	X/R Ratio	Ik'' [kA]	Ik'' [kA]
Griffinrath A 110 kV	7.18	9.46	8.96	7.49	9.67	9.49	6.62	11.55	10.94	7.10	11.29	11.09
Griffinrath B 110 kV	8.37	10.12	9.55	8.48	10.79	10.57	7.74	12.47	11.78	8.02	12.73	12.48
Harolds 110 kV	11.37	10.17	9.44	5.45	12.42	12.04	10.65	13.93	12.62	4.75	16.05	15.42
Heuston 110 kV	13.88	11.62	10.61	8.17	14.31	13.77	13.81	14.12	12.77	7.79	16.94	16.24
Huntstown A 220 kV	13.55	14.12	12.60	12.45	18.19	17.27	15.46	24.29	21.25	12.78	28.62	27.05
Huntstown B 220 kV	14.47	14.40	12.88	11.44	17.95	17.09	14.50	22.62	20.13	10.35	25.98	24.77
Ikerrin 110 kV	5.25	4.16	4.02	6.04	3.22	3.19	5.78	5.67	5.17	6.47	3.82	3.74
Inchicore 220 kV	13.92	17.87	15.35	10.69	22.08	20.64	13.67	26.98	23.30	9.57	31.08	29.24
Inchicore A 110 kV	26.59	12.76	11.56	23.98	16.09	15.42	30.06	15.72	14.09	25.80	19.34	18.45
Inchicore B 110 kV	37.81	13.11	11.37	31.29	16.57	15.56	48.01	15.27	13.56	35.35	18.93	17.98
Inniscarra 110 kV	4.93	8.53	8.09	6.00	8.09	7.95	4.56	11.36	10.54	5.89	9.69	9.48
Irishtown 220 kV	14.62	16.76	14.52	12.03	21.15	19.82	15.11	25.40	22.04	11.36	29.87	28.13
Kellis 110 kV	6.21	7.86	7.52	7.11	9.46	9.29	6.55	10.60	9.88	7.63	12.02	11.69
Kellis 220 kV	8.04	7.21	6.88	9.70	6.33	6.24	7.95	8.73	8.38	9.74	7.24	7.16
Kilbarry 110 kV	7.91	15.86	14.42	8.44	17.08	16.48	7.19	24.82	21.69	8.01	23.20	22.19
Kildonan 110 kV	9.06	17.01	15.46	6.90	15.33	14.88	8.60	22.08	20.36	6.50	18.26	17.84
Kilgarvan 110 kV	8.80	5.24	5.09	6.71	3.57	3.55	9.09	7.29	6.76	6.55	4.04	3.98
Kilkenny 110 kV	3.00	4.68	4.54	3.41	5.76	5.68	3.71	7.90	7.39	4.29	8.75	8.53
Kill Hill 110 kV	4.82	5.06	4.87	5.75	4.89	4.83	5.69	7.50	6.72	6.73	6.24	6.05
Killonan 110 kV	7.46	14.76	13.51	8.46	16.87	16.30	7.23	23.65	20.98	8.61	23.80	22.82
Killonan 220 kV	8.28	8.74	8.16	10.28	8.66	8.46	7.89	12.38	11.68	10.34	10.87	10.68
Killoteran 110 kV	6.26	9.99	9.49	5.34	11.11	10.89	5.51	12.41	11.48	4.86	13.10	12.74
Kilmahud 110 kV	17.33	11.60	10.05	12.28	12.91	12.20	22.38	17.97	16.43	22.51	13.29	12.99
Kilmore 110 kV	15.94	12.98	11.81	11.77	14.93	14.39	17.15	17.39	15.47	11.63	18.79	17.98
Kilpaddoge 110 kV	11.84	13.66	12.65	12.32	17.38	16.81	12.53	20.03	18.23	13.14	23.79	22.89
Kilpaddoge 220 kV	12.08	11.63	10.70	11.15	15.48	14.89	15.90	25.33	22.60	13.75	30.42	28.98
Kilteel 110 kV	4.46	6.97	6.63	5.49	6.46	6.36	4.25	8.67	8.13	5.40	7.40	7.26
Kinnegad 110 kV	4.56	7.16	6.81	5.92	6.58	6.48	4.59	9.15	8.68	6.16	7.65	7.54
Knockacummer 110 kV	5.88	4.82	4.71	6.03	5.23	5.19	6.04	7.22	6.49	6.22	6.95	6.70
Knockearagh 110 kV	5.45	5.03	4.84	7.18	4.40	4.35	5.28	6.24	5.78	7.22	5.05	4.94

Table E-3 Ireland Short Circuit Currents for Maximum and Minimum Demand in 2019

Station	Summer						Winter					
	Three phase			Single phase			Three phase			Single phase		
	X/R Ratio	Ik'' [kA]	Ik'' [kA]	X/R Ratio	Ik'' [kA]	Ik'' [kA]	X/R Ratio	Ik'' [kA]	Ik'' [kA]	X/R Ratio	Ik'' [kA]	Ik'' [kA]
Knocknagoshel 110 kV	6.48	4.83	4.72	6.92	5.72	5.67	6.91	7.81	6.52	7.49	8.29	7.73
Knockraha A 110 kV	9.17	17.04	15.49	9.76	17.70	17.10	7.84	25.26	22.52	8.85	23.06	22.23
Knockraha A 220 kV	11.68	12.87	11.62	11.75	14.56	13.98	10.48	20.56	18.45	10.73	20.46	19.69
Knockraha B 110 kV	9.17	17.04	15.49	9.76	17.70	17.10	7.84	25.26	22.52	8.85	23.06	22.23
Knockraha B 220 kV	11.68	12.87	11.62	11.75	14.56	13.98	10.48	20.56	18.45	10.73	20.46	19.69
Knockumber 110 kV	3.86	7.73	7.29	4.66	5.86	5.77	3.54	9.04	8.51	4.48	6.49	6.39
Lanesboro 110 kV	4.08	9.88	9.12	5.17	10.46	10.16	3.74	12.23	11.04	4.93	12.10	11.69
Laois 110 kV	-	-	-	-	-	-	7.05	15.01	14.13	7.46	18.31	17.86
Laois 400 kV	-	-	-	-	-	-	14.12	8.04	7.68	9.98	7.40	7.29
Letterkenny 110 kV	3.82	5.47	5.17	4.44	6.36	6.23	4.23	10.66	8.85	5.32	10.12	9.50
Liberty A 110 kV	6.57	13.88	12.74	5.49	15.87	15.35	5.87	20.70	18.37	4.87	21.16	20.28
Liberty B 110 kV	6.46	13.87	12.73	5.32	15.84	15.32	5.75	20.67	18.35	4.70	21.10	20.22
Limerick 110 kV	5.78	13.05	11.98	6.44	12.79	12.42	5.14	19.33	17.32	6.09	16.41	15.88
Lisdrum 110 kV	2.89	4.67	4.51	4.15	4.17	4.13	2.81	5.76	5.31	4.24	4.64	4.53
Lisheen 110 kV	3.94	3.22	3.13	3.95	4.82	4.76	5.00	5.21	4.54	5.00	7.81	7.27
Lodgewood 110 kV	8.40	7.25	6.98	8.81	9.12	8.98	8.75	9.53	8.88	8.98	11.22	10.90
Lodgewood 220 kV	8.79	6.67	6.38	9.99	6.56	6.47	8.70	8.21	7.82	9.90	7.62	7.50
Longpoint 220 kV	12.07	11.83	10.69	12.17	14.49	13.87	11.74	18.46	16.51	11.68	20.44	19.57
Louth 220 kV	10.73	13.80	12.40	11.34	16.43	15.71	9.54	20.09	18.26	10.46	21.78	21.00
Louth A 110 kV	7.32	11.34	10.65	8.30	13.78	13.42	6.51	14.20	13.19	7.60	16.65	16.17
Louth B 110 kV	7.89	12.20	11.40	8.67	15.19	14.76	6.96	15.50	14.34	7.87	18.64	18.06
Macetown 110 kV	7.74	16.04	14.62	7.60	16.03	15.53	7.13	20.51	18.96	7.17	19.13	18.65
Macroom 110 kV	7.20	12.02	11.18	7.13	13.70	13.32	7.11	18.91	16.86	6.98	18.89	18.15
Mallow 110 kV	5.27	6.03	5.78	6.91	5.33	5.27	5.21	7.49	7.00	7.08	6.12	6.00
Marina 110 kV	7.89	15.18	13.83	8.79	17.52	16.88	7.46	23.65	20.68	8.67	24.14	23.01
Maynooth A 110 kV	11.06	11.71	10.97	11.67	14.40	14.01	10.34	14.75	13.83	11.09	17.61	17.15
Maynooth A 220 kV	11.06	14.78	13.19	10.41	14.47	13.91	9.33	20.99	19.14	9.30	18.86	18.32
Maynooth B 110 kV	8.51	15.30	13.97	9.85	15.07	14.62	7.59	18.95	17.75	9.20	17.69	17.33
Maynooth B 220 kV	11.37	16.29	14.44	10.56	16.09	15.42	9.65	24.30	21.99	9.20	21.92	21.24
McDermott 110 kV	15.30	9.87	9.24	6.41	11.79	11.48	16.04	12.78	11.54	6.01	14.58	14.00

Table E-3 Ireland Short Circuit Currents for Maximum and Minimum Demand in 2019

Station	Summer						Winter					
	Three phase			Single phase			Three phase			Single phase		
	X/R Ratio	Ik'' [kA]	Ik'' [kA]	X/R Ratio	Ik'' [kA]	Ik'' [kA]	X/R Ratio	Ik'' [kA]	Ik'' [kA]	X/R Ratio	Ik'' [kA]	Ik'' [kA]
Meath Hill 110 kV	4.07	7.99	7.60	5.19	6.83	6.73	3.81	9.95	9.25	5.09	7.79	7.64
Meentycat 110 kV	3.26	4.07	3.91	4.10	4.16	4.11	3.60	7.22	6.20	4.93	5.89	5.64
Midleton 110 kV	3.93	9.36	8.82	4.89	7.66	7.54	3.40	11.57	10.83	4.56	8.66	8.51
Milltown A 110 kV	14.91	10.86	10.04	7.42	13.50	13.06	14.87	15.13	13.64	6.58	17.80	17.06
Milltown B 110 kV	9.09	10.34	9.51	4.26	12.36	11.95	8.73	12.42	11.31	3.99	14.43	13.89
Misery Hill 110 kV	13.60	10.64	9.85	8.10	13.32	12.89	13.23	14.77	13.32	7.27	17.54	16.81
Moneteen 110 kV	5.87	9.95	9.21	6.56	7.77	7.61	5.31	12.60	11.65	6.28	8.79	8.62
Moneypoint 110 kV	13.82	7.98	7.67	16.04	8.30	8.19	15.64	10.64	10.08	18.56	10.09	9.91
Moneypoint 220 kV	12.52	11.70	10.76	11.61	15.57	14.98	16.28	25.04	22.41	14.07	30.16	28.77
Moneypoint G1 400 kV	16.01	7.36	6.74	17.01	9.25	8.90	24.14	14.21	13.06	24.52	15.90	15.38
Moneypoint G2 400 kV	16.01	7.36	6.74	17.01	9.25	8.90	24.14	14.21	13.06	24.52	15.90	15.38
Moneypoint G3 400 kV	16.01	7.36	6.74	17.01	9.25	8.90	24.14	14.21	13.06	24.52	15.90	15.38
Monread 110 kV	4.18	6.88	6.54	5.03	6.97	6.85	3.93	8.59	8.09	4.88	8.10	7.94
Mount Lucas 110 kV	4.43	6.17	5.81	5.59	5.83	5.72	4.74	8.82	8.23	6.19	7.31	7.17
Moy 110 kV	3.72	3.79	3.54	4.39	4.48	4.36	5.64	7.17	6.35	6.87	7.06	6.77
Mullagharlin 110 kV	3.87	8.04	7.64	4.88	7.87	7.74	3.47	9.62	9.02	4.57	8.96	8.78
Mullingar 110 kV	3.57	6.49	6.21	4.91	6.23	6.14	3.44	7.72	7.29	4.87	6.97	6.84
Mulreevy 110 kV	3.60	4.68	4.49	4.11	5.55	5.46	4.57	9.96	8.05	5.05	9.93	9.18
Mungret A 110 kV	5.50	9.48	8.81	6.22	7.24	7.10	4.96	11.87	11.02	5.95	8.13	7.98
Mungret B 110 kV	5.49	9.50	8.82	6.21	7.25	7.11	4.95	11.90	11.04	5.95	8.13	7.99
Nangor 110 kV	15.58	11.40	9.90	10.38	12.67	11.99	12.60	13.67	12.21	7.51	16.40	15.64
Navan 110 kV	5.71	11.38	10.57	6.45	11.25	10.98	5.16	14.18	13.07	6.08	13.19	12.85
Nenagh 110 kV	3.33	3.53	3.41	4.06	2.46	2.44	3.31	4.67	4.23	4.14	2.75	2.70
Newbridge 110 kV	4.40	9.13	8.50	5.09	9.38	9.15	4.11	12.60	11.69	4.96	11.73	11.45
Newbury 110 kV	14.09	12.71	11.58	7.73	14.28	13.78	14.58	16.94	15.09	7.25	17.81	17.07
Nore 110 kV	2.93	4.45	4.32	3.43	5.57	5.50	3.51	7.28	6.85	4.23	8.29	8.09
North Kerry 220 kV	8.48	8.45	7.94	6.10	11.14	10.83	12.69	19.22	17.35	7.28	23.31	22.32
North Kerry A 110 kV	15.02	8.51	8.18	12.33	10.32	10.15	23.49	15.05	12.84	16.59	16.16	15.21
North Kerry B 110 kV	5.00	7.19	6.86	5.87	6.25	6.16	4.69	9.30	8.63	5.75	7.19	7.05
North Quays 110 kV	17.61	11.04	10.20	6.96	13.52	13.07	18.59	15.46	13.93	6.12	17.81	17.07

Table E-3 Ireland Short Circuit Currents for Maximum and Minimum Demand in 2019

Station	Summer						Winter					
	Three phase			Single phase			Three phase			Single phase		
	X/R Ratio	Ik'' [kA]	Ik'' [kA]	X/R Ratio	Ik'' [kA]	Ik'' [kA]	X/R Ratio	Ik'' [kA]	Ik'' [kA]	X/R Ratio	Ik'' [kA]	Ik'' [kA]
North Wall 220 kV	13.38	13.50	12.11	9.33	16.00	15.29	14.67	22.77	20.06	8.38	23.93	22.81
Oldcourt A 110 kV	4.30	9.51	8.97	4.83	7.66	7.53	3.74	11.76	11.05	4.51	8.63	8.50
Oldcourt B 110 kV	4.35	9.57	9.02	4.86	7.73	7.61	3.78	11.85	11.13	4.53	8.73	8.59
Oldstreet 220 kV	12.97	7.08	6.74	11.55	8.32	8.15	15.55	11.66	11.05	12.32	12.21	11.98
Oldstreet 400 kV	14.11	6.01	5.62	9.98	6.10	5.95	16.03	9.22	8.80	9.59	8.20	8.08
Oughtragh 110 kV	3.73	4.10	3.96	4.80	2.82	2.79	3.58	4.92	4.59	4.76	3.04	3.00
Pelletstown 110 kV	13.56	9.41	8.84	8.11	10.44	10.19	13.84	12.04	10.95	7.78	12.67	12.24
Platin 110 kV	5.20	11.28	10.53	5.80	8.71	8.56	4.62	13.70	12.80	5.47	9.87	9.70
Pollaphuca 110 kV	2.75	2.40	2.36	3.96	2.24	2.23	3.29	3.16	3.04	4.73	2.59	2.56
Poolbeg A 110 kV	23.60	11.52	10.62	20.40	14.73	14.22	28.33	16.20	14.57	22.13	19.75	18.89
Poolbeg A 220 kV	13.98	13.60	12.19	8.20	15.32	14.66	15.51	22.94	20.21	7.09	22.52	21.53
Poolbeg B 110 kV	23.58	11.50	10.61	20.39	14.72	14.21	28.29	16.17	14.55	22.12	19.73	18.87
Poolbeg B 220 kV	13.33	16.68	14.46	10.24	19.40	18.27	13.33	24.94	21.76	9.39	26.68	25.31
Poolbeg C 110 kV	19.36	11.23	10.37	8.00	13.79	13.33	21.29	15.82	14.22	7.13	18.27	17.50
Poppintree 110 kV	13.46	12.65	11.55	8.48	14.47	13.96	13.77	16.86	15.06	8.03	18.12	17.36
Portan 260 kV	21.61	8.43	7.95	81.08	2.94	2.92	21.98	12.31	11.89	99.49	3.06	3.05
Portan 400 kV	18.26	6.64	6.19	17.60	7.64	7.44	17.73	9.44	9.02	17.36	10.36	10.18
Portlaoise 110 kV	4.04	7.99	7.53	5.31	7.51	7.37	5.48	14.53	13.55	6.56	13.04	12.76
Pottery 110 kV	17.03	10.38	9.60	5.85	10.69	10.40	17.44	12.71	11.51	5.57	12.42	12.01
Prospect 220 kV	11.33	10.51	9.74	8.90	12.19	11.82	12.67	19.85	18.17	8.26	19.39	18.81
Raffeen 220 kV	12.55	12.49	11.21	12.24	15.42	14.72	11.68	19.56	17.43	11.23	21.92	20.93
Raffeen A 110 kV	8.10	12.97	12.00	8.88	15.43	14.95	7.20	17.45	15.99	8.17	19.50	18.85
Raffeen B 110 kV	9.35	12.46	11.54	10.10	14.82	14.36	8.30	16.82	15.36	9.28	18.74	18.09
Rathkeale 110 kV	3.65	6.45	6.18	4.81	5.36	5.29	3.43	8.03	7.57	4.77	6.11	6.02
Ratrussan 110 kV	3.19	5.82	5.60	3.99	6.60	6.50	3.67	8.31	7.10	4.84	8.54	8.07
Reamore 110 kV	4.42	5.83	5.59	3.57	5.42	5.35	4.34	7.56	6.90	3.42	6.27	6.11
Richmond A 110 kV	3.23	6.67	6.30	4.36	6.08	5.98	3.01	7.89	7.29	4.22	6.85	6.69
Richmond B 110 kV	3.23	6.67	6.30	4.36	6.08	5.98	3.01	7.89	7.29	4.22	6.85	6.69
Rinawade 110 kV	5.11	9.88	9.28	6.03	7.30	7.18	4.70	11.64	11.13	5.80	8.14	8.05
Ringaskiddy 110 kV	6.40	10.55	9.88	6.59	10.46	10.23	5.54	13.60	12.62	6.02	12.42	12.13

Table E-3 Ireland Short Circuit Currents for Maximum and Minimum Demand in 2019

Station	Summer						Winter					
	Three phase			Single phase			Three phase			Single phase		
	X/R Ratio	Ik'' [kA]	Ik'' [kA]	X/R Ratio	Ik'' [kA]	Ik'' [kA]	X/R Ratio	Ik'' [kA]	Ik'' [kA]	X/R Ratio	Ik'' [kA]	Ik'' [kA]
Ringsend 110 kV	23.54	11.51	10.61	21.06	14.74	14.22	28.84	16.36	14.66	23.44	19.94	19.04
Ryebrook 110 kV	5.61	13.11	11.87	6.49	11.86	11.50	5.04	15.72	14.58	6.11	13.40	13.11
Salthill 110 kV	4.94	9.04	8.49	4.08	11.14	10.85	5.38	14.33	12.77	3.99	16.00	15.30
Screeb 110 kV	3.60	2.39	2.31	3.64	3.18	3.13	3.92	3.14	2.82	3.93	4.02	3.83
Seal Rock A 110 kV	8.72	9.55	8.53	10.31	10.65	10.19	7.75	10.62	9.59	9.40	11.35	10.93
Seal Rock B 110 kV	8.75	9.56	8.53	10.32	10.65	10.19	7.78	10.63	9.59	9.42	11.36	10.93
Shankill 110 kV	3.69	7.09	6.74	4.70	6.68	6.57	3.80	9.81	8.58	5.05	8.25	7.93
Shannonbridge 110 kV	6.79	14.85	13.38	8.30	16.96	16.27	5.90	17.83	16.13	7.45	19.33	18.62
Shannonbridge 220 kV	7.95	6.50	6.17	10.33	5.78	5.69	7.16	7.71	7.44	9.72	6.46	6.40
Shellybanks A 220 kV	13.74	13.58	12.17	8.13	16.90	16.11	15.21	22.89	20.17	6.90	25.82	24.53
Shellybanks B 220 kV	13.95	16.14	14.04	10.52	20.11	18.90	14.55	24.43	21.30	9.73	28.24	26.66
Shelton Abbey 110 kV	7.58	6.76	6.49	7.60	7.28	7.17	7.37	8.51	7.96	7.45	8.65	8.45
Singland 110 kV	6.80	12.40	11.49	7.65	12.71	12.37	6.69	18.74	16.93	7.79	16.60	16.09
Sligo 110 kV	3.95	7.29	6.90	4.53	7.32	7.18	3.67	10.99	9.91	4.46	9.58	9.28
Somerset 110 kV	3.10	7.10	6.76	4.06	4.69	4.64	2.86	8.21	7.79	3.93	5.12	5.07
Sorne Hill 110 kV	2.69	2.20	2.14	3.33	2.55	2.52	3.34	3.68	3.26	4.24	3.69	3.53
Srananagh 110 kV	4.79	8.24	7.77	5.49	9.39	9.18	4.73	13.03	11.63	5.69	13.22	12.70
Srananagh 220 kV	6.72	3.98	3.83	8.79	3.40	3.36	7.63	5.33	5.07	9.43	4.20	4.14
Stevenstown 110 kV	4.32	5.65	5.39	4.80	3.77	3.73	4.07	6.70	6.26	4.68	4.14	4.08
Stratford 110 kV	3.14	3.67	3.58	4.11	2.98	2.96	3.36	4.71	4.47	4.38	3.41	3.36
Suir 110 kV	4.34	6.88	6.56	5.12	8.16	8.01	4.43	9.15	8.38	5.40	9.99	9.67
Taney 110 kV	8.99	9.01	8.42	3.36	9.00	8.80	8.66	10.80	9.92	3.18	10.27	9.99
Tarbert 110 kV	20.54	10.60	10.10	23.15	11.77	11.56	35.22	16.94	15.79	35.97	16.07	15.70
Tarbert 220 kV	11.77	11.41	10.51	11.53	14.99	14.44	15.43	24.38	21.80	14.28	28.41	27.12
Tawnaghmore A 110 kV	3.33	3.10	2.92	4.14	3.33	3.26	4.66	5.57	5.05	6.02	4.80	4.66
Tawnaghmore B 110 kV	3.90	3.42	3.17	4.71	3.98	3.86	5.50	5.95	5.35	7.03	5.82	5.62
Thornsberry 110 kV	4.09	5.64	5.37	5.24	5.40	5.31	4.20	7.75	7.28	5.61	6.58	6.46
Thurles 110 kV	5.06	4.20	4.05	5.45	4.86	4.79	6.24	6.73	5.86	6.51	6.88	6.54
Tievebrack 110 kV	3.38	3.25	3.13	4.51	2.58	2.56	3.66	5.10	4.58	5.10	3.20	3.13
Tipperary 110 kV	5.03	6.19	5.94	5.98	4.70	4.65	5.23	8.18	7.60	6.24	5.40	5.31

Table E-3 Ireland Short Circuit Currents for Maximum and Minimum Demand in 2019

Station	Summer						Winter					
	Three phase			Single phase			Three phase			Single phase		
	X/R Ratio	Ik'' [kA]	Ik'' [kA]	X/R Ratio	Ik'' [kA]	Ik'' [kA]	X/R Ratio	Ik'' [kA]	Ik'' [kA]	X/R Ratio	Ik'' [kA]	Ik'' [kA]
Tonroe 110 kV	2.67	3.08	3.00	3.74	1.94	1.93	2.72	3.77	3.50	3.84	2.14	2.11
Trabeg 110 kV	8.00	15.10	13.76	8.74	17.25	16.63	7.49	23.28	20.40	8.49	23.59	22.51
Tralee 110 kV	5.00	7.32	6.95	5.96	6.76	6.65	4.93	10.03	8.98	6.04	8.06	7.81
Trien A 110 kV	4.68	6.65	6.34	5.78	6.17	6.08	4.45	8.67	7.98	5.73	7.18	7.01
Trien B 110 kV	10.51	6.57	6.37	8.84	7.18	7.10	11.81	10.97	9.33	9.05	10.23	9.69
Trillick 110 kV	2.73	2.36	2.29	3.40	2.57	2.55	3.43	4.05	3.54	4.36	3.68	3.53
Trinity 110 kV	12.23	10.39	9.63	6.85	12.90	12.49	11.61	14.33	12.95	6.05	16.86	16.17
Tullabrack 110 kV	6.84	6.21	6.01	7.43	5.08	5.03	6.72	8.08	7.68	7.45	5.83	5.75
Turlough 220 kV	11.93	11.23	10.18	12.96	10.30	9.97	10.43	13.38	12.43	11.87	11.53	11.28
Tynagh 220 kV	10.26	6.77	6.45	11.24	8.42	8.25	14.96	13.04	12.08	16.54	13.94	13.55
Uggool 110 kV	5.29	6.00	5.76	5.03	7.88	7.74	6.34	8.76	8.20	5.66	10.90	10.60
Waterford 110 kV	7.42	10.86	10.27	7.55	12.20	11.94	6.48	13.70	12.61	6.83	14.59	14.15
West Galway A 110 kV	3.97	4.38	4.21	4.23	5.39	5.30	5.01	6.89	5.95	5.23	7.67	7.25
West Galway B 110 kV	5.27	6.27	6.00	4.81	8.20	8.04	6.25	9.17	8.56	5.25	11.36	11.03
Wexford 110 kV	3.92	5.66	5.45	5.02	5.50	5.43	4.01	7.32	6.59	5.28	6.49	6.29
Whitegate 110 kV	4.81	8.97	8.47	5.53	9.30	9.11	4.24	10.84	10.24	5.09	10.62	10.42
Wolfe Tone 110 kV	13.84	9.69	9.08	5.87	11.45	11.16	14.20	12.49	11.30	5.49	14.09	13.55
Woodhouse 110 kV	5.95	5.66	5.49	7.26	4.30	4.27	5.89	7.16	6.67	7.37	4.91	4.83
Woodland 220 kV	13.34	15.99	14.32	13.00	17.73	16.98	11.52	23.89	21.80	11.72	24.38	23.60
Woodland 400 kV	19.29	6.66	6.21	18.78	7.68	7.47	19.15	9.49	9.06	18.88	10.46	10.28
Barnakyle 110 kV	2.89	4.67	4.51	4.15	4.17	4.13	2.81	5.76	5.31	4.24	4.64	4.53
Bunkimalta 110 kV	5.28	5.14	4.95	5.53	5.36	5.29	6.61	8.14	7.15	6.44	7.36	7.06
Castletown 110 kV	6.01	9.30	8.78	5.81	7.84	7.71	5.51	11.09	10.46	5.52	8.78	8.65
Cloghboola 110 kV	6.48	4.83	4.72	6.92	5.72	5.67	6.91	7.81	6.52	7.49	8.29	7.73
Coomataggart 110 kV	8.80	5.24	5.09	6.71	3.57	3.55	9.09	7.29	6.76	6.55	4.04	3.98
Cureeny 110 kV	4.72	4.80	4.64	5.33	5.11	5.05	5.96	7.63	6.70	6.55	7.09	6.79
Glentanemacelligot 110 kV	8.50	5.39	5.25	8.31	4.57	4.54	8.26	7.40	6.91	8.20	5.35	5.26
Knockanure 110 kV	5.00	7.19	6.86	5.87	6.25	6.16	4.69	9.30	8.63	5.75	7.19	7.05
Knockanure 220 kV	8.48	8.45	7.94	6.10	11.14	10.83	12.69	19.22	17.35	7.28	23.31	22.32
Knockranny 110 kV	5.27	6.27	6.00	4.81	8.20	8.04	6.25	9.17	8.56	5.25	11.36	11.03

Table E-3 Ireland Short Circuit Currents for Maximum and Minimum Demand in 2019

Station	Summer						Winter					
	Three phase			Single phase			Three phase			Single phase		
	X/R Ratio	Ik'' [kA]	Ik'' [kA]	X/R Ratio	Ik'' [kA]	Ik'' [kA]	X/R Ratio	Ik'' [kA]	Ik'' [kA]	X/R Ratio	Ik'' [kA]	Ik'' [kA]
North Mayo 110 kV	3.43	3.40	3.23	3.81	4.26	4.17	5.21	6.87	5.91	5.83	7.37	6.96
North Mayo 400 kV	-	-	-	-	-	-	13.73	2.37	2.23	14.51	2.89	2.81
Oriel 220 kV	9.81	10.66	9.85	8.31	10.99	10.69	9.46	15.55	14.22	7.78	14.21	13.80
Oweniney 110 kV	3.43	3.40	3.23	3.81	4.26	4.17	5.21	6.87	5.91	5.83	7.37	6.96
Sliabh Bawn 110 kV	3.45	8.20	7.73	4.41	7.95	7.80	3.45	10.60	9.65	4.58	9.29	9.03
West Dublin 110 kV	-	-	-	-	-	-	23.95	18.28	16.70	24.51	13.55	13.24
West Dublin 220 kV	-	-	-	-	-	-	10.86	26.09	22.98	9.11	25.97	24.82
Belgard 110 kV	12.27	11.44	10.41	6.97	14.00	13.45	12.05	13.83	12.48	6.60	16.49	15.81
Knockalough 110 kV	4.04	4.03	3.89	3.87	4.93	4.86	5.00	6.06	5.33	4.42	6.78	6.45
Buffy 110 kV	3.97	4.36	4.19	4.25	5.36	5.28	5.02	6.85	5.92	5.27	7.65	7.22
Slievecallan 110 kV	4.91	6.78	6.50	5.72	6.74	6.64	5.48	9.98	8.81	6.33	8.60	8.29
Clonee 220 kV	9.84	8.35	7.76	8.53	5.98	5.87	8.97	10.74	10.13	8.10	7.01	6.92

Table E-4 Ireland Short Circuit Currents for Maximum and Minimum Demand in 2022

Station	Summer						Winter					
	Three phase			Single phase			Three phase			Single phase		
	X/R Ratio	Ik'' [kA]	Ik'' [kA]	X/R Ratio	Ik'' [kA]	Ik'' [kA]	X/R Ratio	Ik'' [kA]	Ik'' [kA]	X/R Ratio	Ik'' [kA]	Ik'' [kA]
Adamstown 110 kV	12.04	10.89	9.99	6.56	13.17	12.70	11.22	13.04	11.70	6.09	15.23	14.57
Agannygal 110 kV	2.81	4.79	4.66	3.86	4.11	4.08	2.93	6.42	5.78	4.22	4.88	4.75
Aghada 110 kV	5.14	8.49	8.06	6.15	9.87	9.67	4.57	10.30	9.80	5.64	11.56	11.35
Aghada A 220 kV	14.65	13.99	12.48	15.71	18.05	17.14	15.08	22.69	20.03	16.13	26.69	25.33
Aghada B 220 kV	14.65	13.99	12.48	15.71	18.05	17.14	15.08	22.69	20.03	16.13	26.69	25.33
Aghada C 220 kV	14.05	13.57	12.15	13.51	17.49	16.63	14.04	21.68	19.24	12.87	25.58	24.33
Aghada D 220 kV	14.65	13.99	12.48	15.71	18.05	17.14	15.08	22.69	20.03	16.13	26.69	25.33
Ahane 110 kV	5.57	11.05	10.35	6.04	8.03	7.90	4.99	15.52	14.40	5.81	9.43	9.29
Anner 110 kV	4.01	5.96	5.68	4.53	4.82	4.76	4.31	8.27	7.65	4.79	5.73	5.62
Ardnacrusha 110 kV	6.36	12.00	11.13	7.78	12.93	12.58	6.47	18.93	17.07	8.51	17.46	16.89
Ardnagappary 110 kV	2.77	1.88	1.84	3.93	1.22	1.21	2.86	2.52	2.31	4.20	1.33	1.31
Arigna 110 kV	4.43	6.17	5.91	5.41	5.22	5.15	4.72	8.67	7.91	5.87	6.20	6.07
Arklow 110 kV	10.38	7.68	7.34	11.17	9.49	9.32	10.36	9.73	9.03	11.24	11.51	11.17
Arklow 220 kV	9.10	7.01	6.66	10.53	6.66	6.55	8.62	8.58	8.16	10.21	7.66	7.55
Artane 110 kV	13.34	9.80	9.20	6.30	11.94	11.62	13.14	12.27	11.13	5.85	14.31	13.76
Arva 110 kV	3.90	8.02	7.58	4.97	6.53	6.43	3.82	10.46	9.49	5.11	7.49	7.32
Athea 110 kV	13.26	7.68	7.43	12.82	8.45	8.35	13.45	13.70	11.55	12.66	12.53	11.85
Athlone 110 kV	4.08	6.45	6.18	4.74	7.33	7.21	4.83	9.87	9.10	5.76	9.70	9.44
Athy 110 kV	4.97	6.82	6.58	5.98	5.77	5.71	4.62	8.01	7.65	5.78	6.43	6.35
Aughinish 110 kV	9.10	9.81	8.74	11.07	10.87	10.39	8.11	11.19	10.11	10.16	11.68	11.26
Ballybeg 110 kV	9.96	6.11	5.86	10.15	7.25	7.13	9.66	7.09	6.73	9.90	8.18	8.01
Ballydine 110 kV	4.03	6.65	6.36	3.84	5.57	5.50	4.23	8.87	8.25	3.91	6.54	6.42
Ballylickey 110 kV	2.82	3.05	2.96	3.91	1.94	1.93	2.93	3.89	3.66	4.05	2.14	2.11
Ballynahulla 110 kV	12.81	8.01	7.71	12.34	8.59	8.48	13.95	13.30	11.86	12.67	12.03	11.60
Ballynahulla 220 kV	7.45	7.53	7.13	7.84	8.41	8.23	7.33	12.56	11.58	7.84	12.06	11.73
Ballyragget 110 kV	5.15	6.26	6.05	6.02	4.85	4.81	4.83	7.25	6.89	5.84	5.28	5.22
Ballyvouskill 110 kV	12.44	8.25	7.93	12.42	9.62	9.47	12.98	13.46	12.05	12.66	13.82	13.29
Ballyvouskill 220 kV	7.01	8.04	7.56	7.72	9.79	9.54	6.78	13.63	12.46	7.78	14.77	14.27
Ballywater 110 kV	4.58	4.96	4.82	3.28	5.25	5.20	4.59	6.21	5.86	3.16	6.10	5.98
Baltrasna 110 kV	6.34	9.77	9.23	7.45	7.65	7.54	5.77	11.33	10.77	7.10	8.38	8.27

Table E-4 Ireland Short Circuit Currents for Maximum and Minimum Demand in 2022

Station	Summer						Winter					
	Three phase			Single phase			Three phase			Single phase		
	X/R Ratio	Ik'' [kA]	Ik'' [kA]	X/R Ratio	Ik'' [kA]	Ik'' [kA]	X/R Ratio	Ik'' [kA]	Ik'' [kA]	X/R Ratio	Ik'' [kA]	Ik'' [kA]
Bancroft 110 kV	12.62	11.34	10.38	7.16	13.23	12.77	11.67	13.31	12.23	6.63	15.11	14.61
Bandon 110 kV	3.31	6.01	5.73	4.37	5.86	5.77	3.00	7.62	7.02	4.18	6.85	6.68
Banoge 110 kV	6.05	5.46	5.27	6.80	4.99	4.94	5.87	6.61	6.21	6.71	5.65	5.55
Barnadivane 110 kV	4.22	7.74	7.38	4.80	7.67	7.55	4.16	11.29	10.23	4.91	9.81	9.52
Barnahealy A 110 kV	6.03	11.45	10.71	6.55	11.93	11.65	5.23	14.92	13.88	5.97	14.43	14.09
Barnahealy B 110 kV	7.33	11.04	10.34	7.74	11.39	11.13	6.37	14.50	13.45	7.07	13.83	13.49
Baroda 110 kV	4.18	8.39	7.93	4.97	9.60	9.39	3.84	10.06	9.46	4.69	11.01	10.76
Barrymore 110 kV	4.00	7.23	6.92	5.49	5.77	5.70	3.66	9.27	8.76	5.39	6.70	6.60
Belcamp 110 kV	14.61	12.97	11.85	9.04	14.66	14.15	15.90	20.31	18.19	7.96	20.25	19.48
Belcamp 220 kV	12.21	14.01	12.56	10.44	17.54	16.71	12.25	24.04	21.17	10.10	27.25	25.88
Bellacorick 400 kV	14.21	4.31	4.22	13.89	6.02	5.96	17.31	6.91	6.19	16.16	9.32	8.86
Bellacorick A 110 kV	3.49	3.55	3.36	3.87	4.36	4.26	5.19	6.97	5.96	5.74	7.40	6.98
Bellacorick B 110 kV	10.99	1.61	1.57	11.67	2.06	2.04	13.91	2.47	2.31	14.68	3.01	2.93
Binbane 110 kV	3.20	3.50	3.37	4.31	3.45	3.41	3.56	6.03	5.38	5.34	4.76	4.61
Blackpool 110 kV	7.79	16.16	14.72	7.88	17.38	16.79	6.89	25.26	22.19	7.25	23.67	22.67
Blackrock 110 kV	11.29	9.69	9.02	2.99	8.88	8.68	10.54	11.56	10.52	2.82	9.93	9.65
Blake 110 kV	4.08	7.79	7.41	5.07	5.37	5.31	3.82	9.20	8.75	4.96	5.90	5.84
Boggeragh 110 kV	6.14	6.58	6.34	7.26	7.10	7.00	6.60	9.49	8.69	7.94	9.09	8.83
Booltiagh 110 kV	6.40	6.46	6.24	7.96	5.63	5.57	6.90	9.44	8.61	8.79	6.87	6.71
Bracklone 110 kV	3.99	8.51	8.06	5.01	7.86	7.73	3.63	10.28	9.72	4.78	8.85	8.71
Brinny A 110 kV	3.17	5.42	5.18	4.21	4.87	4.80	2.89	6.71	6.23	4.06	5.56	5.45
Brinny B 110 kV	3.17	5.44	5.20	4.21	4.90	4.83	2.89	6.74	6.26	4.06	5.60	5.49
Butlerstown 110 kV	5.95	9.64	9.18	5.67	9.87	9.70	5.29	11.82	11.01	5.23	11.44	11.18
Cabra 110 kV	12.41	9.50	8.92	5.13	10.81	10.55	12.11	11.83	10.75	4.76	12.76	12.31
Cahir 110 kV	4.36	7.44	7.07	5.01	8.41	8.24	5.78	12.99	11.62	6.66	12.16	11.73
Carlow 110 kV	5.67	8.02	7.68	6.39	8.65	8.51	5.56	10.16	9.43	6.36	10.27	10.01
Carrickmines 220 kV	14.55	16.02	14.08	9.99	19.81	18.71	11.57	23.08	20.40	7.95	26.71	25.38
Carrickmines A 110 kV	29.07	11.07	10.23	23.79	12.23	11.87	28.37	13.41	12.12	22.98	14.17	13.66
Carrickmines B 110 kV	24.02	12.50	11.41	20.35	15.00	14.45	22.94	14.89	13.63	19.31	17.38	16.77
Carrick-on-Shannon 110 kV	4.43	9.39	8.81	5.02	10.70	10.44	4.33	13.84	12.54	5.13	14.16	13.68

Table E-4 Ireland Short Circuit Currents for Maximum and Minimum Demand in 2022

Station	Summer						Winter					
	Three phase			Single phase			Three phase			Single phase		
	X/R Ratio	Ik'' [kA]	Ik'' [kA]	X/R Ratio	Ik'' [kA]	Ik'' [kA]	X/R Ratio	Ik'' [kA]	Ik'' [kA]	X/R Ratio	Ik'' [kA]	Ik'' [kA]
Carrigadrohid 110 kV	7.02	11.23	10.53	7.15	11.20	10.96	6.65	16.68	15.18	6.92	14.41	14.01
Carrowbeg 110 kV	2.70	2.51	2.42	3.56	2.39	2.36	2.77	3.57	3.29	3.85	2.97	2.90
Cashla 110 kV	7.32	12.54	11.62	7.62	16.26	15.72	7.12	21.44	19.33	7.56	25.35	24.30
Cashla 220 kV	8.25	8.03	7.54	9.09	8.87	8.65	8.36	13.46	12.66	9.54	12.61	12.36
Castlebar 110 kV	3.16	4.27	4.05	3.73	4.75	4.66	4.02	8.13	7.06	4.86	7.70	7.35
Castledockrill 110 kV	6.75	6.48	6.27	4.85	7.89	7.78	6.78	8.29	7.80	4.63	9.44	9.22
Castlefarm A 110 kV	8.13	9.45	8.45	9.53	10.10	9.68	7.26	10.75	9.73	8.78	10.83	10.46
Castlefarm B 110 kV	8.15	9.43	8.43	9.55	10.08	9.67	7.27	10.73	9.72	8.79	10.82	10.45
Castleview 110 kV	4.36	11.23	10.52	4.83	8.51	8.36	3.65	14.46	13.48	4.44	9.81	9.65
Cathleen's Fall 110 kV	4.29	6.36	6.03	4.93	7.27	7.12	5.22	13.44	11.61	6.24	12.20	11.64
Cauteen 110 kV	5.36	6.45	6.20	6.26	4.45	4.40	6.17	9.62	8.92	6.82	5.28	5.21
Central 110 kV	14.56	10.16	9.44	7.92	10.99	10.70	13.66	12.14	11.06	7.44	12.58	12.16
Charleville 110 kV	4.55	5.65	5.42	5.98	5.27	5.20	4.74	7.77	7.06	6.52	6.53	6.35
Cherrywood 110 kV	10.54	9.43	8.79	7.71	9.69	9.45	9.83	11.12	10.19	7.30	10.95	10.63
City West 110 kV	6.21	7.22	6.76	6.13	5.54	5.45	5.86	8.44	7.63	5.94	6.01	5.87
Clahane 110 kV	4.23	6.47	6.19	5.20	6.07	5.99	4.02	8.59	7.94	5.14	7.15	6.99
Clashavoon 220 kV	8.12	8.23	7.72	8.84	9.84	9.59	7.30	13.81	12.63	8.34	14.60	14.12
Clashavoon A 110 kV	7.95	12.88	12.00	8.24	16.61	16.10	7.90	20.66	18.42	8.23	24.51	23.37
Clashavoon B 110 kV	7.95	12.88	12.00	8.24	16.61	16.10	7.90	20.66	18.42	8.23	24.51	23.37
Cliff 110 kV	4.04	5.22	4.99	4.98	5.39	5.30	4.52	9.44	8.47	5.91	7.68	7.45
Clogher 110 kV	3.92	5.31	5.06	4.23	6.37	6.25	5.72	14.45	11.92	6.41	17.13	15.78
Clogher 220 kV	-	-	-	-	-	-	8.14	5.39	4.91	10.17	5.56	5.37
Cloghran 110 kV	9.94	18.99	17.11	9.73	20.24	19.47	8.92	24.63	22.57	8.94	24.40	23.68
Clonkeen A 110 kV	5.75	5.60	5.40	6.81	4.17	4.14	5.50	6.81	6.46	6.73	4.64	4.58
Clonkeen B 110 kV	5.38	6.51	6.31	4.58	7.65	7.56	5.34	10.30	9.18	4.31	10.82	10.37
Cloon 110 kV	4.47	6.67	6.36	5.76	6.03	5.94	4.08	9.03	8.45	5.67	7.23	7.10
College Park 110 kV	9.66	18.19	16.46	6.74	20.38	19.61	8.69	23.37	21.51	6.01	24.68	23.94
Cookstown 110 kV	7.42	8.01	7.53	6.02	6.83	6.71	6.94	9.08	8.57	5.77	7.47	7.35
Coolroe 110 kV	5.35	9.02	8.55	6.58	8.66	8.51	4.85	12.01	11.17	6.37	10.40	10.18
Coomagearlahy 110 kV	5.33	5.24	5.10	5.75	6.24	6.17	5.75	8.31	7.29	6.30	8.97	8.53

Table E-4 Ireland Short Circuit Currents for Maximum and Minimum Demand in 2022

Station	Summer						Winter					
	Three phase			Single phase			Three phase			Single phase		
	X/R Ratio	Ik'' [kA]	Ik'' [kA]	X/R Ratio	Ik'' [kA]	Ik'' [kA]	X/R Ratio	Ik'' [kA]	Ik'' [kA]	X/R Ratio	Ik'' [kA]	Ik'' [kA]
Cordal 110 kV	10.50	7.00	6.78	8.59	6.63	6.56	11.18	11.40	10.23	8.28	8.79	8.54
Corderry 110 kV	4.05	6.35	6.07	4.97	6.33	6.24	4.41	9.91	8.75	5.68	8.27	7.97
Corduff 110 kV	10.72	20.30	18.18	11.79	23.03	22.05	9.65	26.78	24.39	10.94	28.45	27.50
Corduff 220 kV	15.21	15.89	14.10	13.93	19.77	18.76	14.07	26.20	23.08	12.41	29.38	27.92
Corkagh 110 kV	22.95	15.40	13.80	22.93	12.08	11.72	20.78	18.05	16.56	21.68	13.27	12.98
Corraclassy 110 kV	4.39	5.74	5.44	5.42	4.72	4.65	4.38	7.21	6.78	5.59	5.28	5.20
Cow Cross 110 kV	5.00	11.41	10.67	5.35	10.11	9.90	4.25	14.79	13.75	4.89	11.91	11.67
Crane 110 kV	6.33	7.06	6.78	6.43	7.70	7.59	6.47	9.30	8.52	6.45	9.32	9.04
Cromcastle A 110 kV	12.36	12.63	11.55	8.03	14.38	13.88	10.49	18.77	16.88	6.18	19.07	18.36
Cromcastle B 110 kV	12.36	12.63	11.55	8.03	14.38	13.88	10.49	18.77	16.88	6.18	19.07	18.36
Cronacarkfree 220 kV	4.29	3.40	3.30	4.39	4.18	4.13	6.21	7.34	6.23	5.82	7.51	7.07
Crory 110 kV	22.12	15.29	13.72	21.93	11.96	11.61	20.01	17.91	16.45	20.73	13.13	12.86
Cuilleen 110 kV	3.94	6.18	5.93	4.73	7.13	7.01	4.69	9.43	8.72	5.93	9.46	9.21
Cullenagh 110 kV	8.02	11.87	11.23	8.50	13.84	13.54	6.90	15.11	14.01	7.57	16.77	16.29
Cullenagh 220 kV	8.95	8.58	8.17	9.18	8.66	8.51	7.96	10.29	9.85	8.46	9.92	9.78
Cunghill 110 kV	3.29	4.61	4.40	3.76	4.48	4.41	3.16	6.80	6.28	3.79	5.66	5.54
Cushaling 110 kV	5.84	9.38	8.56	7.11	11.04	10.64	6.82	13.45	12.14	8.69	14.04	13.53
Dallow 110 kV	3.48	4.67	4.54	4.56	3.06	3.04	3.45	5.72	5.41	4.66	3.34	3.30
Dalton 110 kV	3.09	3.76	3.61	4.13	3.29	3.25	3.28	5.68	5.17	4.63	4.09	3.99
Dardistown 110 kV	13.73	12.51	11.45	10.61	14.49	13.98	10.11	18.49	16.67	5.76	18.71	18.03
Derrybrien 110 kV	2.67	3.79	3.71	3.73	3.66	3.63	2.98	5.15	4.55	4.42	4.50	4.34
Derryiron 110 kV	5.05	7.69	7.28	6.23	8.11	7.96	5.71	10.58	9.89	7.29	9.97	9.76
Doon 110 kV	4.30	6.49	6.17	4.71	5.46	5.38	4.84	9.27	8.52	5.08	6.61	6.47
Dromada 110 kV	8.68	7.33	7.10	5.83	7.82	7.73	7.39	12.74	10.83	4.78	11.24	10.68
Drumkeen 110 kV	3.54	4.80	4.59	4.19	5.06	4.98	3.74	9.67	8.37	4.82	7.83	7.51
Drumline 110 kV	3.59	7.25	6.91	4.76	6.30	6.21	3.20	9.53	8.85	4.60	7.34	7.20
Drybridge 110 kV	5.82	12.50	11.59	6.72	10.56	10.34	5.00	15.57	14.28	6.19	12.08	11.81
Dundalk 110 kV	3.75	8.01	7.62	4.72	7.43	7.32	3.40	9.92	9.16	4.52	8.57	8.37
Dunfirth 110 kV	4.70	5.99	5.76	6.32	4.76	4.71	4.51	6.79	6.58	6.25	5.10	5.06
Dungarvan 110 kV	5.94	5.76	5.57	7.68	4.86	4.81	5.85	7.51	6.93	7.86	5.73	5.62

Table E-4 Ireland Short Circuit Currents for Maximum and Minimum Demand in 2022

Station	Summer						Winter					
	Three phase			Single phase			Three phase			Single phase		
	X/R Ratio	Ik'' [kA]	Ik'' [kA]	X/R Ratio	Ik'' [kA]	Ik'' [kA]	X/R Ratio	Ik'' [kA]	Ik'' [kA]	X/R Ratio	Ik'' [kA]	Ik'' [kA]
Dunmanway 110 kV	4.31	7.19	6.84	5.19	6.61	6.51	4.21	10.22	9.23	5.28	8.14	7.92
Dunstown 220 kV	13.02	16.82	15.03	12.53	19.47	18.58	6.50	24.20	22.26	7.27	25.93	25.14
Dunstown 400 kV	17.25	6.86	6.36	18.17	7.74	7.51	3.40	10.91	10.35	4.74	11.02	10.82
Ennis 110 kV	5.06	9.41	8.89	6.31	8.78	8.63	5.10	14.58	12.86	6.72	11.32	10.94
Fassaroe East 110 kV	5.33	7.50	7.07	5.42	5.78	5.69	4.98	8.54	8.03	5.23	6.28	6.19
Fassaroe West 110 kV	5.48	7.65	7.21	5.52	5.96	5.87	5.11	8.73	8.20	5.32	6.50	6.40
Finglas 220 kV	14.81	15.23	13.54	14.44	19.62	18.60	14.84	25.99	22.72	13.85	30.38	28.71
Finglas A 110 kV	20.83	13.84	12.58	17.62	15.89	15.30	16.44	20.58	18.33	13.31	21.26	20.39
Finglas B 110 kV	27.75	10.88	10.15	26.47	13.81	13.41	33.00	13.87	12.51	29.57	16.99	16.26
Flagford 110 kV	4.71	9.77	9.14	5.34	12.30	11.96	4.67	14.62	13.21	5.57	17.05	16.37
Flagford 220 kV	7.09	6.13	5.80	7.80	7.48	7.31	7.96	9.79	9.15	8.88	10.79	10.52
Flagford 400 kV	10.83	2.22	2.14	10.88	2.72	2.68	13.87	3.30	3.12	12.97	3.73	3.65
Francis Street A 110 kV	10.87	11.74	10.84	5.31	14.01	13.56	10.16	13.95	12.63	4.96	16.14	15.51
Francis Street B 110 kV	13.10	11.54	10.58	6.83	14.05	13.55	12.19	13.73	12.45	6.32	16.23	15.59
Galway 110 kV	5.04	9.81	9.17	4.60	12.21	11.87	5.17	16.49	14.75	4.46	18.38	17.60
Garrow 110 kV	9.23	7.93	7.63	9.44	9.31	9.16	9.34	12.90	11.55	9.54	13.38	12.85
Garvagh 110 kV	4.25	4.99	4.81	5.43	4.85	4.79	4.87	7.36	6.55	6.48	6.05	5.85
Gilra 110 kV	3.27	5.80	5.54	4.04	4.72	4.66	3.02	7.18	6.78	3.96	5.28	5.20
Glanagow 220 kV	14.93	13.82	12.33	14.75	17.75	16.86	14.85	21.77	19.30	14.15	25.65	24.38
Glanlee 110 kV	5.30	5.08	4.96	5.46	6.06	6.00	5.71	7.97	7.01	5.83	8.64	8.23
Glasmore A 110 kV	4.40	6.93	6.53	4.88	4.87	4.80	3.74	8.62	7.93	4.50	5.39	5.30
Glenlara A 110 kV	2.94	2.64	2.55	4.20	2.34	2.31	3.14	3.35	3.04	4.65	2.74	2.67
Glenlara B 110 kV	9.00	5.91	5.75	6.92	5.96	5.90	9.17	9.28	8.29	6.48	7.96	7.69
Glenree 110 kV	3.44	3.83	3.62	4.16	3.72	3.65	3.74	6.93	6.32	4.77	5.31	5.18
Golagh 110 kV	3.59	4.64	4.45	4.02	4.80	4.73	4.03	10.42	8.99	4.62	9.02	8.62
Gorman 110 kV	6.71	13.24	12.22	7.63	14.58	14.14	6.46	17.92	15.96	7.60	18.17	17.44
Gorman 220 kV	9.57	10.15	9.41	10.20	8.67	8.48	8.53	13.11	12.39	9.61	10.10	9.96
Gortawee 110 kV	4.46	5.63	5.32	5.86	4.79	4.72	4.47	6.87	6.40	6.11	5.30	5.20
Grange 110 kV	12.15	12.53	11.46	6.08	13.89	13.42	10.82	18.85	16.93	4.87	18.45	17.79
Grange Castle 110 kV	14.50	11.55	10.54	9.50	14.33	13.78	13.56	13.98	12.45	8.84	16.81	16.01

Table E-4 Ireland Short Circuit Currents for Maximum and Minimum Demand in 2022

Station	Summer						Winter					
	Three phase			Single phase			Three phase			Single phase		
	X/R Ratio	Ik'' [kA]	Ik'' [kA]	X/R Ratio	Ik'' [kA]	Ik'' [kA]	X/R Ratio	Ik'' [kA]	Ik'' [kA]	X/R Ratio	Ik'' [kA]	Ik'' [kA]
Great Island 110 kV	7.58	11.93	11.31	8.36	15.46	15.10	6.54	14.69	13.64	7.35	18.45	17.88
Great Island 220 kV	12.00	10.97	10.35	13.41	13.12	12.81	10.23	12.99	12.31	11.70	14.81	14.51
Griffinrath A 110 kV	7.14	9.77	9.26	7.46	9.90	9.72	6.49	11.53	10.94	7.00	11.22	11.03
Griffinrath B 110 kV	8.36	10.47	9.89	8.46	11.08	10.85	7.57	12.45	11.79	7.89	12.67	12.43
Harolds 110 kV	11.06	11.77	10.88	5.02	13.97	13.53	10.34	13.98	12.66	4.68	16.08	15.46
Heuston 110 kV	14.14	11.76	10.76	8.20	14.47	13.94	13.19	14.03	12.70	7.59	16.77	16.10
Huntstown A 220 kV	14.16	14.71	13.13	12.87	18.96	18.00	14.34	24.97	21.93	12.05	29.22	27.67
Huntstown B 220 kV	15.13	14.97	13.39	11.70	18.65	17.75	13.67	23.22	20.75	9.90	26.47	25.29
Ikerrin 110 kV	5.09	4.05	3.92	5.90	3.18	3.15	5.83	5.76	5.28	6.51	3.83	3.75
Inchicore 220 kV	14.76	18.42	15.90	10.95	22.74	21.30	11.49	27.83	24.14	8.57	31.86	30.04
Inchicore A 110 kV	28.06	12.92	11.74	24.94	16.28	15.62	27.31	15.64	14.04	23.98	19.20	18.34
Inchicore B 110 kV	41.00	12.42	11.31	32.75	15.79	15.16	41.83	15.22	13.51	32.22	18.81	17.88
Inniscarra 110 kV	4.91	8.68	8.25	5.99	8.19	8.05	4.51	11.60	10.80	5.85	9.79	9.59
Irishtown 220 kV	15.37	17.29	15.04	12.38	21.79	20.45	12.65	26.09	22.73	10.07	30.59	28.86
Kellis 110 kV	6.77	8.61	8.25	7.75	10.19	10.01	6.42	10.76	10.05	7.51	12.16	11.84
Kellis 220 kV	8.45	7.43	7.10	10.06	6.46	6.37	7.53	8.88	8.55	9.40	7.30	7.22
Kilbarry 110 kV	7.91	16.31	14.85	8.52	17.70	17.08	7.01	25.63	22.47	7.96	24.24	23.20
Kildonan 110 kV	9.24	17.36	15.79	6.95	15.58	15.13	8.38	22.12	20.47	6.40	18.15	17.76
Kilgarvan 110 kV	8.99	5.35	5.21	6.75	3.61	3.58	9.00	8.13	7.44	6.47	4.27	4.21
Kilkenny 110 kV	3.96	6.85	6.59	4.50	7.90	7.78	3.67	7.98	7.48	4.26	8.80	8.59
Kill Hill 110 kV	4.76	5.03	4.85	5.68	4.86	4.80	6.27	8.30	7.45	7.23	6.61	6.41
Killonan 110 kV	7.47	14.96	13.71	7.61	12.83	12.50	7.22	24.27	21.68	7.48	16.61	16.17
Killonan 220 kV	8.10	8.82	8.25	10.30	8.10	7.93	7.85	12.63	11.99	10.63	10.04	9.90
Killoteran 110 kV	6.12	10.26	9.75	5.25	11.33	11.11	5.38	12.69	11.77	4.78	13.31	12.95
Kilmahud 110 kV	22.51	15.32	13.73	22.64	12.04	11.69	20.38	17.93	16.47	21.40	13.22	12.94
Kilmore 110 kV	16.31	13.34	12.14	11.87	15.29	14.73	14.73	20.33	18.14	8.94	20.69	19.87
Kilpaddoge 110 kV	12.77	14.36	13.29	13.22	18.27	17.67	12.22	21.22	19.45	12.80	25.20	24.32
Kilpaddoge 220 kV	13.65	12.95	11.87	13.04	17.20	16.52	13.16	29.34	26.42	11.90	34.30	32.84
Kilteel 110 kV	4.57	7.43	7.06	5.62	6.67	6.57	4.21	8.64	8.12	5.36	7.35	7.21
Kinnegad 110 kV	4.59	7.39	7.02	5.95	6.70	6.60	4.56	9.13	8.67	6.13	7.62	7.51

Table E-4 Ireland Short Circuit Currents for Maximum and Minimum Demand in 2022

Station	Summer						Winter					
	Three phase			Single phase			Three phase			Single phase		
	X/R Ratio	Ik'' [kA]	Ik'' [kA]	X/R Ratio	Ik'' [kA]	Ik'' [kA]	X/R Ratio	Ik'' [kA]	Ik'' [kA]	X/R Ratio	Ik'' [kA]	Ik'' [kA]
Knockacummer 110 kV	5.95	4.97	4.85	6.11	5.34	5.30	5.87	7.50	6.76	6.11	7.12	6.87
Knockearagh 110 kV	5.49	5.15	4.95	7.24	4.47	4.42	5.33	6.45	5.95	7.32	5.15	5.04
Knocknagoshel 110 kV	6.74	5.20	5.09	7.20	6.09	6.04	6.82	8.56	7.17	7.46	8.77	8.21
Knockraha A 110 kV	9.23	17.57	15.99	9.69	17.98	17.39	7.64	26.21	23.46	8.60	23.56	22.75
Knockraha A 220 kV	11.75	13.34	12.06	11.49	14.66	14.09	10.29	21.18	19.09	10.30	20.46	19.74
Knockraha B 110 kV	9.23	17.57	15.99	9.69	17.98	17.39	7.64	26.21	23.46	8.60	23.56	22.75
Knockraha B 220 kV	11.75	13.34	12.06	11.49	14.66	14.09	10.29	21.18	19.09	10.30	20.46	19.74
Knockumber 110 kV	3.84	7.94	7.49	4.66	5.98	5.89	3.51	9.38	8.71	4.49	6.52	6.41
Lanesboro 110 kV	3.23	7.79	7.41	3.97	8.77	8.60	3.69	12.36	11.21	4.90	11.95	11.57
Laois 110 kV	7.71	12.29	11.59	8.02	15.44	15.05	6.92	15.72	14.86	7.36	19.04	18.60
Laois 400 kV	15.45	6.48	6.04	13.02	6.97	6.79	4.81	12.28	11.58	5.98	10.77	10.58
Letterkenny 110 kV	3.84	5.49	5.20	4.45	6.42	6.29	4.11	11.69	9.93	5.23	10.87	10.30
Liberty A 110 kV	6.54	14.21	13.06	5.44	16.21	15.68	5.76	21.30	18.96	4.79	21.81	20.91
Liberty B 110 kV	6.43	14.20	13.06	5.27	16.18	15.65	5.63	21.27	18.94	4.62	21.74	20.85
Limerick 110 kV	5.80	13.25	12.17	6.71	11.92	11.61	5.08	19.75	17.80	6.38	15.04	14.63
Lisdrum 110 kV	2.89	4.75	4.59	4.16	4.19	4.14	2.79	5.73	5.28	4.22	4.61	4.51
Lisheen 110 kV	3.91	3.19	3.11	3.92	4.78	4.72	4.98	5.38	4.72	4.98	8.07	7.53
Lodgewood 110 kV	8.34	7.34	7.07	8.75	9.22	9.07	8.63	9.56	8.92	8.87	11.24	10.93
Lodgewood 220 kV	8.77	6.78	6.49	9.98	6.64	6.54	8.50	8.25	7.88	9.74	7.63	7.52
Longpoint 220 kV	14.43	13.86	12.38	13.16	17.64	16.76	14.33	22.19	19.64	12.19	25.68	24.41
Louth 220 kV	10.98	13.65	12.34	11.51	16.21	15.55	9.56	21.02	19.16	10.47	22.52	21.75
Louth A 110 kV	7.34	11.47	10.78	8.32	13.94	13.58	6.34	14.25	13.24	7.45	16.62	16.14
Louth B 110 kV	7.90	12.37	11.56	8.68	15.39	14.96	6.78	15.88	14.69	7.71	18.95	18.36
Macetown 110 kV	7.84	16.35	14.92	7.67	16.29	15.79	6.96	20.53	19.03	7.06	19.08	18.62
Macroom 110 kV	7.30	12.43	11.58	7.20	14.07	13.69	7.04	19.63	17.54	6.93	19.51	18.76
Mallow 110 kV	5.26	6.07	5.83	6.91	5.35	5.29	5.18	7.60	7.11	7.06	6.18	6.06
Marina 110 kV	7.88	15.58	14.22	8.76	17.94	17.30	7.28	24.40	21.40	8.49	24.95	23.80
Maynooth A 110 kV	11.16	12.17	11.41	11.78	14.90	14.50	10.02	14.75	13.88	10.79	17.57	17.15
Maynooth A 220 kV	11.15	15.83	14.11	10.50	15.43	14.83	8.00	21.65	19.86	8.44	19.11	18.61
Maynooth B 110 kV	8.60	15.72	14.38	9.95	15.41	14.96	7.42	18.95	17.83	9.06	17.59	17.26

Table E-4 Ireland Short Circuit Currents for Maximum and Minimum Demand in 2022

Station	Summer						Winter					
	Three phase			Single phase			Three phase			Single phase		
	X/R Ratio	Ik'' [kA]	Ik'' [kA]	X/R Ratio	Ik'' [kA]	Ik'' [kA]	X/R Ratio	Ik'' [kA]	Ik'' [kA]	X/R Ratio	Ik'' [kA]	Ik'' [kA]
Maynooth B 220 kV	11.78	17.64	15.58	10.58	17.48	16.73	8.50	25.28	23.03	8.51	22.34	21.70
McDermott 110 kV	15.59	10.05	9.42	6.40	12.00	11.68	15.74	12.68	11.46	5.94	14.41	13.85
Meath Hill 110 kV	4.11	8.24	7.82	5.24	6.95	6.85	3.82	10.24	9.48	5.14	7.88	7.72
Meentycat 110 kV	3.27	4.14	3.98	4.10	4.23	4.17	3.47	7.66	6.72	4.83	6.13	5.91
Midleton 110 kV	3.90	9.50	8.96	4.87	7.71	7.58	3.46	12.09	11.30	4.64	8.85	8.70
Milltown A 110 kV	15.19	12.71	11.68	6.93	15.37	14.84	14.27	15.20	13.71	6.45	17.85	17.11
Milltown B 110 kV	9.15	10.44	9.64	4.24	12.49	12.09	8.48	12.32	11.22	3.93	14.25	13.73
Misery Hill 110 kV	13.61	12.41	11.42	7.62	15.14	14.62	12.75	14.83	13.37	7.12	17.59	16.86
Moneteen 110 kV	5.88	10.06	9.32	6.68	7.57	7.42	5.27	12.84	11.92	6.39	8.58	8.44
Moneypoint 110 kV	14.69	8.24	7.93	17.24	8.54	8.43	15.44	10.97	10.44	18.42	10.33	10.17
Moneypoint 220 kV	14.00	13.03	11.94	13.36	17.30	16.61	13.26	28.58	25.84	12.03	33.62	32.25
Moneypoint G1 400 kV	18.65	9.06	8.21	19.81	11.10	10.65	11.31	17.55	16.11	13.51	18.51	17.93
Moneypoint G2 400 kV	18.65	9.06	8.21	19.81	11.10	10.65	11.31	17.55	16.11	13.51	18.51	17.93
Moneypoint G3 400 kV	18.65	9.06	8.21	19.81	11.10	10.65	11.31	17.55	16.11	13.51	18.51	17.93
Monread 110 kV	4.22	7.32	6.97	5.10	7.26	7.14	3.90	8.57	8.08	4.86	8.07	7.92
Mount Lucas 110 kV	4.51	6.60	6.23	5.71	6.08	5.97	4.71	8.82	8.25	6.16	7.34	7.20
Moy 110 kV	3.79	3.90	3.63	4.46	4.58	4.45	5.57	8.72	7.61	6.85	8.38	8.00
Mullagharlin 110 kV	3.87	8.15	7.76	4.88	7.96	7.83	3.44	9.80	9.17	4.58	9.03	8.85
Mullingar 110 kV	3.59	6.44	6.17	4.90	6.18	6.09	3.41	7.73	7.30	4.85	7.00	6.88
Mulreavy 110 kV	3.61	4.76	4.56	3.93	5.79	5.69	4.60	11.68	9.74	3.80	13.36	12.40
Mungret A 110 kV	5.50	9.59	8.91	6.33	7.07	6.94	4.92	12.09	11.27	6.05	7.96	7.83
Mungret B 110 kV	5.49	9.61	8.92	6.32	7.07	6.94	4.91	12.12	11.29	6.04	7.96	7.84
Nangor 110 kV	12.98	11.28	10.32	7.89	13.93	13.41	12.10	13.59	12.14	7.32	16.26	15.51
Navan 110 kV	5.71	11.76	10.90	6.47	11.52	11.24	5.31	15.28	13.73	6.26	13.70	13.26
Nenagh 110 kV	3.33	3.55	3.43	4.05	2.43	2.41	3.30	4.69	4.25	4.13	2.72	2.66
Newbridge 110 kV	4.47	10.10	9.44	5.18	10.04	9.82	4.07	12.63	11.74	4.92	11.74	11.47
Newbury 110 kV	14.32	13.06	11.89	7.71	14.61	14.10	12.64	19.73	17.65	5.90	19.47	18.73
Nore 110 kV	3.74	6.36	6.14	4.43	7.52	7.41	3.48	7.35	6.92	4.20	8.34	8.15
North Kerry 220 kV	12.16	10.94	10.15	8.54	14.43	13.95	11.49	21.59	19.70	6.70	25.67	24.70
North Kerry A 110 kV	22.41	9.65	9.26	17.70	11.54	11.35	21.26	17.23	14.69	15.36	17.80	16.79

Table E-4 Ireland Short Circuit Currents for Maximum and Minimum Demand in 2022

Station	Summer						Winter					
	Three phase			Single phase			Three phase			Single phase		
	X/R Ratio	Ik'' [kA]	Ik'' [kA]	X/R Ratio	Ik'' [kA]	Ik'' [kA]	X/R Ratio	Ik'' [kA]	Ik'' [kA]	X/R Ratio	Ik'' [kA]	Ik'' [kA]
North Kerry B 110 kV	5.01	7.42	7.07	5.89	6.39	6.30	4.61	9.68	9.02	5.71	7.43	7.29
North Quays 110 kV	18.66	12.96	11.90	6.46	15.40	14.87	17.67	15.54	13.99	6.01	17.86	17.12
North Wall 220 kV	13.94	14.05	12.60	9.45	16.61	15.87	13.28	23.31	20.60	7.95	24.22	23.12
Oldcourt A 110 kV	4.28	9.66	9.12	4.81	7.71	7.59	3.70	12.06	11.36	4.48	8.82	8.69
Oldcourt B 110 kV	4.32	9.72	9.17	4.84	7.79	7.66	3.73	12.15	11.44	4.50	8.91	8.78
Oldstreet 220 kV	13.78	7.52	7.15	12.01	8.79	8.62	14.77	12.67	12.05	11.81	12.92	12.70
Oldstreet 400 kV	14.54	6.86	6.39	9.83	6.75	6.59	10.49	12.49	11.86	7.73	9.65	9.52
Oughtragh 110 kV	3.73	4.19	4.04	4.80	2.85	2.83	3.57	5.07	4.73	4.78	3.10	3.05
Pelletstown 110 kV	13.76	9.58	9.00	8.12	10.60	10.36	13.61	11.93	10.86	7.70	12.51	12.09
Platin 110 kV	5.17	11.54	10.75	5.79	8.87	8.71	4.47	14.04	13.02	5.39	9.88	9.70
Pollaphuca 110 kV	2.76	2.48	2.44	4.00	2.28	2.27	3.26	3.18	3.06	4.71	2.61	2.58
Poolbeg A 110 kV	27.12	13.52	12.39	21.95	16.88	16.26	26.27	16.27	14.64	21.00	19.82	18.96
Poolbeg A 220 kV	14.63	14.15	12.69	8.25	15.88	15.20	13.03	23.52	20.78	6.61	22.76	21.79
Poolbeg B 110 kV	27.09	13.50	12.37	21.94	16.87	16.24	26.24	16.25	14.62	20.99	19.81	18.94
Poolbeg B 220 kV	14.41	17.38	15.13	10.61	20.11	18.98	11.41	25.61	22.45	8.56	27.16	25.83
Poolbeg C 110 kV	21.11	13.23	12.13	7.50	15.75	15.20	20.10	15.90	14.29	6.98	18.32	17.55
Poppintree 110 kV	13.68	13.00	11.86	8.49	14.82	14.29	11.58	19.29	17.29	7.14	19.85	19.08
Portan 260 kV	22.48	10.53	9.81	100.43	3.13	3.11	16.50	15.10	14.50	99.95	3.34	3.33
Portan 400 kV	18.27	8.51	7.81	16.48	9.66	9.34	12.16	13.58	12.85	12.17	14.11	13.83
Portlaoise 110 kV	5.90	11.45	10.76	6.79	11.12	10.89	5.42	14.84	13.89	6.53	13.17	12.91
Pottery 110 kV	17.40	10.51	9.74	5.84	10.79	10.51	16.44	12.65	11.46	5.47	12.32	11.92
Prospect 220 kV	12.31	11.39	10.54	9.24	13.05	12.65	11.06	22.05	20.39	7.64	20.88	20.34
Raffeen 220 kV	13.06	12.93	11.63	11.50	16.17	15.43	12.21	20.15	18.02	10.25	23.04	22.02
Raffeen A 110 kV	8.06	13.23	12.26	8.79	15.70	15.22	7.07	17.92	16.47	7.99	20.00	19.36
Raffeen B 110 kV	9.34	12.71	11.79	10.02	15.08	14.62	8.20	17.35	15.89	9.10	19.31	18.67
Rathkeale 110 kV	3.71	6.71	6.40	4.92	5.44	5.37	3.40	8.17	7.73	4.77	6.15	6.07
Ratrussan 110 kV	3.20	5.92	5.69	4.00	6.72	6.62	3.62	8.29	7.09	4.79	8.49	8.03
Reamore 110 kV	4.42	5.98	5.74	3.56	5.53	5.45	4.50	8.12	7.33	3.46	6.56	6.38
Richmond A 110 kV	2.88	5.70	5.48	3.81	5.54	5.47	2.98	7.95	7.37	4.20	6.83	6.68
Richmond B 110 kV	2.88	5.70	5.48	3.81	5.54	5.47	2.98	7.95	7.37	4.20	6.83	6.68

Table E-4 Ireland Short Circuit Currents for Maximum and Minimum Demand in 2022

Station	Summer						Winter					
	Three phase			Single phase			Three phase			Single phase		
	X/R Ratio	Ik'' [kA]	Ik'' [kA]	X/R Ratio	Ik'' [kA]	Ik'' [kA]	X/R Ratio	Ik'' [kA]	Ik'' [kA]	X/R Ratio	Ik'' [kA]	Ik'' [kA]
Rinawade 110 kV	5.10	10.08	9.48	6.03	7.40	7.29	4.64	11.57	11.10	5.77	8.05	7.97
Ringaskiddy 110 kV	6.37	10.72	10.06	6.54	10.58	10.36	5.49	13.96	12.99	5.95	12.70	12.42
Ringsend 110 kV	27.59	13.62	12.46	23.16	17.01	16.37	26.71	16.44	14.74	22.18	20.02	19.11
Ryebrook 110 kV	5.62	13.37	12.13	6.51	12.05	11.69	4.96	15.65	14.57	6.04	13.26	12.99
Salthill 110 kV	5.09	9.08	8.52	4.17	11.21	10.91	5.33	15.11	13.48	3.92	16.65	15.94
Screeb 110 kV	3.62	2.43	2.35	3.66	3.24	3.19	4.43	3.54	3.14	4.36	4.46	4.22
Seal Rock A 110 kV	8.73	9.65	8.61	10.33	10.72	10.26	7.76	10.98	9.93	9.45	11.51	11.09
Seal Rock B 110 kV	8.76	9.66	8.61	10.35	10.72	10.26	7.79	10.99	9.93	9.47	11.51	11.09
Shankill 110 kV	3.71	7.19	6.83	4.72	6.76	6.65	3.75	9.82	8.59	5.02	8.23	7.92
Shannonbridge 110 kV	5.14	11.04	10.42	6.03	13.39	13.08	6.11	18.76	16.97	7.76	20.20	19.46
Shannonbridge 220 kV	6.64	6.11	5.85	8.82	5.58	5.50	7.26	7.73	7.49	9.89	6.46	6.40
Shellybanks A 220 kV	14.36	14.13	12.67	8.18	17.57	16.75	12.75	23.49	20.75	8.12	24.29	23.19
Shellybanks B 220 kV	14.57	16.63	14.53	10.73	20.69	19.48	12.33	25.06	21.92	8.79	28.89	27.32
Shelton Abbey 110 kV	7.58	6.87	6.60	7.60	7.37	7.26	7.23	8.51	7.97	7.35	8.63	8.43
Singland 110 kV	6.82	12.53	11.62	7.69	11.46	11.20	6.66	19.09	17.35	7.79	14.57	14.21
Sligo 110 kV	3.99	7.34	6.93	4.55	7.44	7.29	3.69	11.35	10.21	4.49	9.76	9.46
Somerset 110 kV	3.13	6.43	6.20	4.01	4.54	4.50	2.83	8.35	7.94	3.92	5.10	5.05
Sorne Hill 110 kV	2.69	2.27	2.21	3.33	2.63	2.60	3.30	3.80	3.39	4.20	3.76	3.62
Srananagh 110 kV	4.84	8.26	7.77	5.49	9.53	9.31	4.92	13.54	12.03	5.89	13.74	13.17
Srananagh 220 kV	6.70	4.00	3.84	8.32	3.58	3.53	7.68	6.71	6.26	9.09	5.34	5.24
Stevenstown 110 kV	4.31	5.76	5.49	4.79	3.81	3.77	3.77	6.87	6.46	4.50	4.13	4.08
Stratford 110 kV	3.17	3.85	3.76	4.16	3.06	3.04	3.33	4.75	4.51	4.36	3.42	3.38
Suir 110 kV	4.29	6.89	6.57	5.07	8.16	8.01	5.86	12.02	10.81	7.27	11.94	11.51
Taney 110 kV	9.03	9.11	8.53	3.34	9.07	8.87	8.41	10.72	9.86	3.15	10.16	9.89
Tarbert 110 kV	22.90	11.12	10.61	25.72	12.18	11.97	33.00	17.75	16.69	34.45	16.54	16.22
Tarbert 220 kV	13.03	12.48	11.47	12.94	16.30	15.68	12.85	27.89	25.20	12.44	31.58	30.33
Tawnaghmore A 110 kV	3.37	3.18	3.00	4.19	3.40	3.33	4.38	6.36	5.74	5.77	5.30	5.15
Tawnaghmore B 110 kV	3.96	3.50	3.25	4.78	4.05	3.93	5.18	6.79	6.08	6.71	6.44	6.21
Thornsberry 110 kV	4.23	6.10	5.79	5.45	5.67	5.58	4.18	7.76	7.29	5.59	6.74	6.62
Thurles 110 kV	4.97	4.17	4.03	5.35	4.81	4.75	6.44	7.05	6.17	6.67	7.12	6.79

Table E-4 Ireland Short Circuit Currents for Maximum and Minimum Demand in 2022

Station	Summer						Winter					
	Three phase			Single phase			Three phase			Single phase		
	X/R Ratio	Ik'' [kA]	Ik'' [kA]	X/R Ratio	Ik'' [kA]	Ik'' [kA]	X/R Ratio	Ik'' [kA]	Ik'' [kA]	X/R Ratio	Ik'' [kA]	Ik'' [kA]
Tievebrack 110 kV	3.39	3.33	3.21	4.51	2.66	2.63	3.61	5.23	4.75	5.07	3.24	3.17
Tipperary 110 kV	4.99	6.20	5.95	5.95	4.64	4.59	5.77	9.07	8.43	6.59	5.56	5.48
Tonroe 110 kV	2.70	3.14	3.05	3.73	2.01	2.00	2.71	3.79	3.51	3.83	2.14	2.11
Trabeg 110 kV	7.99	15.49	14.14	8.71	17.64	17.02	7.31	24.01	21.11	8.32	24.31	23.22
Tralee 110 kV	5.01	7.54	7.16	5.98	6.91	6.80	5.04	10.69	9.51	6.20	8.37	8.11
Trien A 110 kV	4.69	6.84	6.53	5.79	6.30	6.21	4.38	9.04	8.34	5.70	7.45	7.28
Trien B 110 kV	12.30	7.26	7.03	9.84	7.76	7.67	11.05	12.15	10.37	8.65	10.87	10.34
Trillick 110 kV	2.74	2.43	2.36	3.41	2.65	2.62	3.38	4.18	3.69	4.31	3.75	3.61
Trinity 110 kV	12.02	12.07	11.13	6.37	14.60	14.12	11.24	14.39	13.00	5.95	16.90	16.21
Tullabrack 110 kV	6.94	6.37	6.17	7.52	5.18	5.13	6.65	8.27	7.88	7.42	5.92	5.85
Turlough 220 kV	11.92	11.57	10.51	12.95	10.53	10.21	8.59	13.76	12.85	10.39	11.68	11.44
Tynagh 220 kV	10.62	7.09	6.74	11.63	8.78	8.60	14.10	13.77	12.82	15.82	14.52	14.14
Uggool 110 kV	5.39	6.06	5.81	5.12	7.97	7.82	6.29	8.97	8.42	5.61	11.11	10.82
Waterford 110 kV	7.26	11.20	10.60	7.42	12.48	12.22	6.31	14.03	12.94	6.69	14.83	14.40
West Galway A 110 kV	4.03	4.44	4.27	4.28	5.47	5.38	5.51	7.77	6.59	5.65	8.38	7.86
West Galway B 110 kV	5.39	6.32	6.05	4.90	8.29	8.13	6.20	9.41	8.81	5.20	11.59	11.28
Wexford 110 kV	3.87	5.74	5.53	4.98	5.55	5.48	3.97	7.36	6.62	5.25	6.53	6.32
Whitegate 110 kV	4.80	9.10	8.61	5.52	9.39	9.20	4.22	11.19	10.59	5.09	10.91	10.71
Wolfe Tone 110 kV	14.06	9.86	9.25	5.86	11.65	11.35	13.95	12.40	11.22	5.43	13.93	13.39
Woodhouse 110 kV	5.92	5.71	5.53	7.24	4.31	4.28	5.83	7.27	6.79	7.33	4.96	4.88
Woodland 220 kV	14.70	17.36	15.48	13.98	19.14	18.30	11.57	26.43	24.16	11.75	26.28	25.47
Woodland 400 kV	19.70	8.56	7.85	18.13	9.74	9.41	13.22	13.69	12.95	13.45	14.29	14.01
Barnakyle 110 kV	2.89	4.75	4.59	4.16	4.19	4.14	2.79	5.73	5.28	4.22	4.61	4.51
Bunkimalta 110 kV	5.28	5.17	4.98	5.65	5.27	5.20	6.59	8.18	7.21	6.61	7.18	6.91
Cahernagh 110 kV	4.28	4.69	4.57	5.32	5.13	5.08	3.95	5.32	5.20	5.06	5.64	5.59
Castletown 110 kV	5.99	9.55	9.00	5.80	8.00	7.87	6.28	12.90	11.56	5.88	9.36	9.11
Cloghboola 110 kV	6.74	5.20	5.09	7.20	6.09	6.04	6.82	8.56	7.17	7.46	8.77	8.21
Coomataggart 110 kV	8.99	5.35	5.21	6.75	3.61	3.58	9.00	8.13	7.44	6.47	4.27	4.21
Cureeny 110 kV	4.72	4.83	4.66	5.51	5.04	4.98	5.94	7.67	6.75	6.88	6.95	6.67
Glentanemacelligot 110 kV	8.76	5.57	5.42	8.49	4.63	4.60	8.20	8.03	7.42	8.17	5.60	5.50

Table E-4 Ireland Short Circuit Currents for Maximum and Minimum Demand in 2022

Station	Summer						Winter					
	Three phase			Single phase			Three phase			Single phase		
	X/R Ratio	Ik'' [kA]	Ik'' [kA]	X/R Ratio	Ik'' [kA]	Ik'' [kA]	X/R Ratio	Ik'' [kA]	Ik'' [kA]	X/R Ratio	Ik'' [kA]	Ik'' [kA]
Knockranny 110 kV	5.39	6.32	6.05	4.90	8.29	8.13	6.20	9.41	8.81	5.20	11.59	11.28
North Mayo 110 kV	3.49	3.55	3.36	3.87	4.36	4.26	5.19	6.97	5.96	5.74	7.40	6.98
North Mayo 400 kV	10.99	1.61	1.57	11.67	2.06	2.04	13.91	2.47	2.31	14.68	3.01	2.93
Oriel 220 kV	9.89	10.59	9.81	8.36	10.99	10.69	9.34	15.95	14.60	7.70	14.63	14.21
Oweniney 110 kV	3.51	3.45	3.27	3.90	4.27	4.17	5.29	6.78	5.80	5.91	7.29	6.87
Sliabh Bawn 110 kV	3.15	7.18	6.86	3.96	7.30	7.19	3.40	10.69	9.76	4.55	9.30	9.05
West Dublin 110 kV	23.90	15.55	13.93	24.52	12.26	11.89	21.66	18.25	16.74	23.19	13.48	13.19
West Dublin 220 kV	12.81	18.45	16.02	10.53	20.03	18.95	9.28	26.99	23.91	8.25	26.47	25.37
Belgard 110 kV	12.46	11.57	10.56	6.97	14.15	13.62	11.57	13.72	12.41	6.45	16.32	15.66
Knockalough 110 kV	4.08	4.09	3.94	3.91	5.01	4.93	5.54	6.88	5.91	4.65	7.45	7.02
Buffy 110 kV	4.02	4.41	4.24	4.29	5.44	5.36	5.51	7.72	6.55	5.69	8.34	7.83
Slievecallan 110 kV	4.97	6.81	6.53	5.78	6.77	6.68	5.45	10.05	8.91	6.33	8.60	8.30
Clonee 220 kV	10.01	8.65	8.05	8.57	6.13	6.02	8.80	10.88	10.30	8.02	6.97	6.89
Kilpaddoge 400 kV	-	-	-	-	-	-	6.47	17.03	15.66	5.81	15.64	15.22

E.6 Short Circuit Currents in Northern Ireland

E.6.1 Methodology Used in Northern Ireland

Short circuit current levels are calculated in accordance with the UK Engineering Recommendation G74, which is a computer based analysis, based on the International Standard IEC60909. Compliance with G74 includes:

- Short circuit current contributions from all synchronous and non-synchronous rotating plant including induction motors embedded in the general load,
- Comprehensive plant parameters including time-dependent impedances, transformer winding and earthing configurations,
- Pre-fault voltage levels at each node which should be obtained from a credible, pre-fault load flow study,
- Pre-fault transformer tap settings should also be obtained from the load flow study.

The short circuit current level network model includes the following component parameters:

- Transformer impedance variation with tap position,
- Zero sequence mutual coupling effect,
- Unsaturated generator reactance values,
- Power station auxiliaries fault level contributions.

The calculation of the X/R ratios, used by SONI, is undertaken in accordance with IEC60909-0 Method C, which is known as the equivalent frequency method. The equivalent frequency method is considered to be the most appropriate general purpose method for calculating the D.C. component of short circuit currents on the Northern Ireland transmission system.

The Northern Ireland transmission system is designed and operated to maintain short circuit current levels below the ratings of equipment at each substation. Table E-5 below, indicates the range of circuit breaker RMS ratings that are currently installed on the Northern Ireland transmission system, for the respective voltage levels currently operated.

Table E-5 Northern Ireland station equipment rating range by voltage level

Voltage Level (kV)	Short Circuit Current Equipment Rating Range (kA)
275	26.5 – 31.5
110	18.4 – 40

E.6.2 Analysis

The generation dispatches used in the short circuit analysis are shown in Table D-8 in Appendix D.

The total RMS break current at a busbar is an indication of the short circuit level that one could expect at that point in the transmission system. However, they do not necessarily represent the short circuit current that could flow through each individual breaker, which may be lower.

E.6.3 Northern Ireland Short Circuit Current Level Results

Tables E-6 to E-11 contain the following three-phase and single-phase short circuit current level results for maximum winter peak and minimum summer valley system demand conditions for 2016, 2019 and 2022:

- **Initial Short Circuit Current (I^{''})**
This is the initial RMS value of the AC component of the short circuit current, prior to contact separation time. It is calculated using generator sub-transient reactances.

- **Peak Make Current (ip)**
The largest peak current occurs around 10ms, and is the short circuit current that equipment must be able to withstand, for example, when a circuit breaker is closed directly onto an earthed section of network, thus energising a fault. All equipment in the fault current path will be subjected to the peak make current, and therefore should be rated to withstand this.
- **RMS Break Current (IB)**
This is the RMS value of the AC component of the short circuit current at the time of circuit breaker contact separation. The break time at which contact separation occurs varies from circuit to circuit, and depends on protection settings, fault location, circuit breaker design etc. For the purposes of this report, we have used a short circuit current break time of 50ms for all 275 kV and 110 kV calculations.
- **Asymmetrical Break Current (asym B)**
This is based on the first peak during contact separation (peak break current). It is the highest short circuit current that a circuit breaker is required to extinguish and is the combination of AC and DC components. The asymmetrical break current is expressed as the equivalent RMS value of this peak break current.

In the Northern Ireland results tables, the RMS Break, Peak Make and Asymmetrical Break ratings of the existing nodes are shown. It should be noted that both the Ballylumford and Kells 110 kV nodes (highlighted in the tables with *) have separate ratings for three-phase and single-phase faults; these are indicated in the tables. All ratings are in kA.

Single phase to earth short circuit currents tend to be larger than three phase short circuit currents in heavily meshed transmission networks. This is due to the multiplicity of zero phase sequence paths available to earth fault currents. In all tables, any nodes where short circuit currents exceed 90% of the corresponding existing rating are highlighted in **orange**. Any nodes where short circuit currents exceed the corresponding existing ratings are highlighted in **red**.

The results presented in the following section are indicative only. They are based on intact network conditions and are representative of the assumed generation dispatch and transmission system conditions.

Table E-6 Northern Ireland Short Circuit Currents for Minimum Demand in 2016

Node	Rating			Three Phase					Single Phase				
	RMS	Peak	Asym	X/R	I''	ip	IB	asym B	X/R	I''	ip	IB	asym B
	[kA]	[kA]	[kA]	ratio	[kA]	[kA]	[kA]	[kA]	ratio	[kA]	[kA]	[kA]	[kA]
275kV													
Ballylumford	31.5	79	35.65	11.33	8.49	21.29	7.46	8.77	11.99	11.26	28.40	10.32	12.24
Castlereagh	31.5	79	35.65	10.91	8.66	21.60	7.56	8.85	10.78	10.42	25.97	9.58	11.13
Coolkeeragh	31.5	79	35.3	10.68	8.24	20.52	7.33	8.76	11.72	9.38	23.60	8.80	10.69
Hannahstown	31.5	79	35.65	10.80	8.40	20.93	7.36	8.56	10.87	10.25	25.56	9.43	11.02
Kells	31.5	79	35.65	12.53	9.69	24.56	8.41	10.42	11.59	11.70	29.40	10.75	12.78
Kilroot	31.5	79	45.3	11.29	8.42	21.09	7.40	8.68	11.89	11.10	27.95	10.18	12.01
Magherafelt	31.5	79	35.65	12.13	9.90	24.99	8.61	10.42	9.98	10.90	26.92	10.09	11.20
Moyle	31.5	79	35.65	11.29	8.42	21.09	7.40	8.68	11.89	11.10	27.95	10.18	12.01
Tandragee	31.5	79	35.65	11.25	10.43	26.11	9.05	10.71	10.59	12.33	30.66	11.31	13.11
Tamnamore	40	100	45.6	11.20	8.81	22.04	7.78	9.01	10.55	9.54	23.71	8.91	10.26
110kV													
Aghyoule	40	100		2.95	2.93	5.70	2.84	2.84	3.89	3.25	6.77	3.18	3.19
Antrim	40	100		4.85	7.72	16.91	7.28	7.42	4.90	8.21	18.01	7.95	8.27
Ballylumford	21.9	55	25.88	7.35	10.87	25.71	10.03	11.69					
	26.2	65	29.7						8.18	13.72	32.98	13.02	15.43
Ballymena	40	100		5.04	7.46	16.47	7.04	7.22	5.51	8.16	18.33	7.89	8.40
Banbridge	18.4	46.8		4.13	5.87	12.40	5.61	5.66	5.05	5.98	13.20	5.83	6.08
Ballyvallyagh	21.9	46.8	23	5.46	10.16	22.78	9.41	9.57	5.05	10.72	23.66	10.27	10.41
Ballynahinch	18.4	46.8		4.28	5.06	10.78	4.82	4.88	5.03	5.25	11.59	5.11	5.34
Belfast Central	31.5	79		8.66	11.18	27.08	10.19	11.18	5.54	14.10	31.70	13.23	14.23
Carnmoney	31.5	79	45	4.15	6.81	14.41	6.44	6.51	4.66	7.27	15.78	7.04	7.27
Castlereagh	26.2	65	33.5	11.35	13.20	33.09	11.86	14.48	12.05	17.63	44.48	16.31	19.97
Coleraine	40	100	45.6	3.71	6.21	12.78	5.85	5.85	4.30	7.49	15.96	7.21	7.23
Coolkeeragh	31.5	80	33.5	11.03	14.82	37.02	13.27	16.85	11.58	19.43	48.80	18.13	22.97
Creagh	31.5	80	33.5	3.69	6.70	13.78	6.35	6.35	4.45	7.34	15.78	7.12	7.18
Cregagh	26.2	65		9.57	12.19	29.94	11.03	12.54	7.54	15.77	37.42	14.70	16.26
Donegall North	31.5	79	33.5	8.49	12.82	30.97	11.66	12.81	5.71	16.44	37.20	15.42	16.17
Donegall South				6.11	10.28	23.55	9.51	9.76	5.00	11.64	25.65	11.11	11.43

Table E-6 Northern Ireland Short Circuit Currents for Minimum Demand in 2016

Node	Rating			Three Phase					Single Phase				
	RMS	Peak	Asym	X/R	I''	ip	IB	asym B	X/R	I''	ip	IB	asym B
	[kA]	[kA]	[kA]	ratio	[kA]	[kA]	[kA]	[kA]	ratio	[kA]	[kA]	[kA]	[kA]
Drumnakelly	31.5	79	42.5	7.88	14.72	35.18	13.27	14.58	7.68	17.18	40.88	16.10	17.68
Dungannon	18.4	46.8	23	5.87	12.32	28.00	11.26	11.81	5.97	13.89	31.69	13.17	13.98
Eden	25	62.5	45	4.25	7.11	15.13	6.72	6.78	4.66	7.62	16.54	7.38	7.59
Enniskillen	31.5	79	33.5	3.50	5.76	11.70	5.45	5.45	4.15	7.28	15.41	7.00	7.01
Finaghy	31.5	79		9.48	13.16	32.28	11.95	13.56	6.84	17.32	40.46	16.19	17.39
Glengormley	18.4	46.8		3.50	4.79	9.73	4.61	4.61	4.19	4.89	10.38	4.79	4.85
Hannahstown	31.5	80	33.5	10.75	14.30	35.63	12.89	15.47	11.16	19.22	48.09	17.85	21.54
Kells	21.9	55.9	27.4	9.88	13.61	33.55	12.35	15.22	-	-	-	-	-
	26.2	65	29.7	-	-	-	-	-	10.34	17.88	44.33	16.74	20.64
Killymallaght	40	100	45	6.09	9.17	20.99	8.54	8.72	5.71	9.49	21.46	9.16	9.51
Knock	18.4	46.8		5.32	11.65	25.99	10.58	10.78	3.27	12.94	25.83	12.22	12.93
Larne	18.4	46.8	42.5	4.66	7.06	15.32	6.68	6.72	5.22	7.34	16.32	7.12	7.33
Limavady	18.4	46.8	23	3.64	5.80	11.88	5.49	5.50	4.28	6.57	13.99	6.37	6.41
Lisburn	18.4	46.8	23	5.34	10.01	22.34	9.28	9.43	4.83	10.48	22.92	10.05	10.39
Lisaghmore	31.5	79		4.85	8.15	17.83	7.63	7.76	4.97	8.41	18.50	8.14	8.47
Loguestown	26.2	65		3.43	4.72	9.53	4.50	4.50	4.03	5.38	11.30	5.23	5.25
Magherakeel Cluster	40	100	45	4.08	3.07	6.46	2.99	2.99	5.13	3.67	8.14	3.62	3.63
Newtownards	40	100		4.82	6.75	14.77	6.36	6.44	5.78	6.77	15.34	6.55	6.83
Newry	18.4	46.8	23	4.00	5.03	10.56	4.82	4.87	4.92	5.15	11.31	5.03	5.24
Omagh	40	100	42.5	4.10	9.03	19.04	8.38	8.40	4.66	10.04	21.80	9.61	9.72
Rathgael	26.2	65		4.33	5.38	11.50	5.12	5.17	5.01	5.54	12.22	5.39	5.61
Rosebank	40	100		9.55	12.60	30.94	11.37	12.94	9.16	16.55	40.41	15.38	17.24
Slieve Kirk	40	100		4.57	6.91	14.94	6.55	6.57	5.37	6.29	14.07	6.15	6.38
Springtown	31.5	79	33.6	5.09	8.32	18.39	7.78	7.95	5.15	8.73	19.36	8.45	8.82
Strabane	18.4	46.8	23	5.25	10.69	23.80	9.85	9.96	5.80	12.47	28.28	11.87	12.28
Tandragee	26.2	65	29.7	9.68	15.93	39.17	14.27	17.25	10.30	20.15	49.94	18.72	22.86
Tamnamore	40	100	45	7.53	11.03	26.18	10.21	11.96	8.34	14.62	35.22	13.86	16.47
Waringstown	18.4	46.8		5.13	7.26	16.09	6.87	7.00	5.68	7.29	16.47	7.08	7.44

Table E-7 Northern Ireland Short Circuit Currents for Maximum Demand in 2016

Node	Rating			Three Phase					Single Phase				
	RMS	Peak	Asym	X/R	I''	ip	IB	asym B	X/R	I''	ip	IB	asym B
	[kA]	[kA]	[kA]	ratio	[kA]	[kA]	[kA]	[kA]	ratio	[kA]	[kA]	[kA]	[kA]
275kV													
Ballylumford	31.5	79	35.65	15.09	20.17	52.00	17.71	23.33	16.10	23.38	60.62	21.75	28.68
Castlereagh	31.5	79	35.65	10.67	16.35	40.69	14.41	16.56	10.54	16.79	41.73	15.68	18.00
Coolkeeragh	31.5	79	35.3	8.71	12.47	30.24	11.47	12.78	10.33	12.71	31.52	12.22	14.16
Hannahstown	31.5	79	35.65	11.03	16.27	40.66	14.38	16.68	11.10	16.94	42.35	15.83	18.59
Kells	31.5	79	35.65	12.71	18.75	47.57	16.61	20.09	11.17	19.27	48.22	18.14	20.99
Kilroot	31.5	79	45.3	14.76	19.68	50.65	17.33	22.54	15.49	22.59	58.39	21.06	27.24
Magherafelt	31.5	79	35.65	11.52	18.40	46.19	16.39	18.97	9.24	16.68	40.78	15.84	17.11
Moyle	31.5	79	35.65	14.76	19.68	50.65	17.33	22.54	15.49	22.59	58.39	21.06	27.24
Tandragee	31.5	79	35.65	10.32	18.76	46.49	16.57	18.67	9.73	18.72	46.07	17.56	19.69
Tamnamore	40	100	45.6	10.51	17.74	44.07	15.81	17.82	10.39	16.90	41.93	15.99	18.43
110kV													
Aghyoule	40	100		4.14	4.16	8.80	3.91	4.06	5.57	4.17	9.39	4.06	4.41
Antrim	40	100		4.16	9.83	20.80	9.38	9.48	4.43	9.73	20.88	9.49	9.79
Ballylumford	21.9	55	25.88	10.88	23.75	59.25	21.81	28.59					
	26.2	65	29.7						12.51	27.50	69.66	26.23	34.97
Ballymena	40	100		4.39	9.50	20.36	9.05	9.21	5.05	9.70	21.41	9.44	9.98
Banbridge	18.4	46.8		4.01	6.54	13.71	6.26	6.30	5.03	6.47	14.27	6.31	6.57
Ballyvally	21.9	46.8	23	4.56	16.35	35.31	15.28	15.33	4.42	14.79	31.74	14.35	14.42
Ballynahinch	18.4	46.8		3.93	5.90	12.32	5.60	5.66	4.82	5.88	12.85	5.70	5.94
Belfast Central	31.5	79		7.15	15.38	36.21	13.94	14.93	4.66	18.23	39.56	16.99	18.08
Belfast North	18.4	46.8		4.29	14.92	31.81	13.81	13.94	2.81	14.72	28.24	14.08	15.01
Carnmoney	31.5	79	45	3.62	8.91	18.24	8.49	8.55	4.30	8.74	18.64	8.51	8.75
Castlereagh	26.2	65	33.5	9.73	19.79	48.69	17.56	21.61	10.67	25.08	62.42	22.90	28.28
Coleraine	40	100	45.6	4.11	9.15	19.31	8.48	8.53	4.87	10.29	22.55	9.88	10.06
Coolkeeragh	31.5	80	33.5	9.28	23.06	56.39	20.80	25.04	10.16	28.30	70.01	26.73	32.47
Creagh	31.5	80	33.5	3.32	8.28	16.59	7.92	7.92	4.18	8.59	18.21	8.37	8.43
Cregagh	26.2	65		7.96	17.51	41.91	15.70	17.50	6.35	21.34	49.22	19.69	21.52

Table E-7 Northern Ireland Short Circuit Currents for Maximum Demand in 2016

Node	Rating			Three Phase					Single Phase				
	RMS	Peak	Asym	X/R	I''	ip	IB	asym B	X/R	I''	ip	IB	asym B
	[kA]	[kA]	[kA]	ratio	[kA]	[kA]	[kA]	[kA]	ratio	[kA]	[kA]	[kA]	[kA]
Donegall North	31.5	79	33.5	7.83	17.57	41.95	16.09	17.39	4.99	21.28	46.88	20.00	20.86
Donegall South				5.51	13.29	29.86	12.40	12.61	4.56	14.09	30.44	13.50	13.80
Drumnakelly	31.5	79	42.5	7.87	17.51	41.84	15.95	17.23	8.00	18.88	45.22	17.80	19.49
Dungannon	18.4	46.8	23	6.59	14.03	32.56	13.14	13.77	6.74	15.01	34.97	14.46	15.44
Eden	25	62.5	45	3.69	10.05	20.67	9.58	9.62	4.27	9.67	20.59	9.44	9.64
Enniskillen	31.5	79	33.5	3.90	8.83	18.41	8.18	8.19	4.93	10.25	22.52	9.84	9.92
Finaghy	31.5	79		9.17	18.35	44.81	16.77	18.94	6.23	23.00	52.87	21.54	22.89
Glengormley	18.4	46.8		3.14	5.61	11.09	5.42	5.42	3.93	5.44	11.35	5.33	5.38
Gort Cluster				6.32	7.77	17.91	7.47	7.60	6.12	7.33	16.79	7.20	7.73
Hannahstown	31.5	80	33.5	10.86	20.56	51.29	18.63	22.76	11.55	26.37	66.23	24.52	30.19
Kells	21.9	55.9	27.4	8.27	21.03	50.60	19.33	23.19					
	26.2	65	29.7						8.99	25.90	63.07	24.53	29.67
Killymallaght	40	100	45	5.78	12.92	29.28	12.13	12.40	5.47	11.86	26.61	11.57	12.08
Knock	18.4	46.8		4.23	16.42	34.89	14.81	14.97	2.86	16.29	31.40	15.32	16.27
Larne	18.4	46.8	42.5	4.05	9.75	20.50	9.31	9.32	4.85	9.15	20.04	8.96	9.14
Limavady	18.4	46.8	23	3.66	7.83	16.08	7.37	7.37	4.47	8.22	17.68	7.98	8.09
Lisburn	18.4	46.8	23	4.80	12.69	27.70	11.87	11.98	4.48	12.33	26.55	11.88	12.22
Lisaghmore	31.5	79		4.17	10.29	21.79	9.74	9.83	4.53	9.84	21.22	9.61	9.92
Loguestown	26.2	65		3.60	6.31	12.89	5.95	5.96	4.30	6.70	14.29	6.50	6.58
Magherakeel Cluster	40	100	45	5.39	4.25	9.51	4.21	4.40	7.03	4.76	11.17	4.73	5.13
Newtownards	40	100		4.24	8.18	17.40	7.72	7.78	5.39	7.70	17.21	7.44	7.73
Newry	18.4	46.8	23	4.01	5.65	11.86	5.36	5.44	5.00	5.58	12.29	5.41	5.70
Omagh	40	100	42.5	4.87	14.97	32.80	13.85	14.01	5.26	15.22	33.89	14.68	15.26
Rasharkin				3.93	6.98	14.59	6.71	6.73	4.57	6.82	14.73	6.69	6.89
Rathgael	26.2	65		3.93	6.31	13.18	5.99	6.03	4.76	6.22	13.56	6.03	6.26
Rosebank	40	100		8.75	18.11	43.95	16.21	18.73	10.10	22.52	55.67	20.73	24.63
Slieve Kirk	40	100		4.38	9.09	19.47	8.69	8.75	5.36	7.34	16.39	7.22	7.68
Springtown	31.5	79	33.6	4.33	10.48	22.39	9.94	10.05	4.65	10.24	22.22	10.01	10.33

Table E-7 Northern Ireland Short Circuit Currents for Maximum Demand in 2016

Node	Rating			Three Phase					Single Phase				
	RMS	Peak	Asym	X/R	I''	ip	IB	asym B	X/R	I''	ip	IB	asym B
	[kA]	[kA]	[kA]	ratio	[kA]	[kA]	[kA]	[kA]	ratio	[kA]	[kA]	[kA]	[kA]
Strabane	18.4	46.8	23	4.70	16.10	35.00	14.82	14.92	5.49	16.91	37.96	16.27	16.81
Tandragee	26.2	65	29.7	10.48	20.53	50.98	18.52	22.51	11.66	24.53	61.67	22.84	28.25
Tamnamore	40	100	45	9.44	18.53	45.42	17.25	20.85	10.48	23.66	58.77	22.58	27.77
Tremoge Cluster				4.24	8.76	18.62	8.45	8.49	4.65	8.15	17.69	8.03	8.29
Waringstown	18.4	46.8		4.97	8.26	18.18	7.84	7.96	5.65	7.98	18.02	7.74	8.12

Table E-8 Northern Ireland Short Circuit Currents for Minimum Demand in 2019

Node	Rating			Three Phase					Single Phase				
	RMS	Peak	Asym	X/R	I''	ip	IB	asym B	X/R	I''	ip	IB	asym B
	[kA]	[kA]	[kA]	ratio	[kA]	[kA]	[kA]	[kA]	ratio	[kA]	[kA]	[kA]	[kA]
275kV													
Ballylumford	31.5	79	35.65	11.47	9.06	22.75	8.00	9.30	12.14	11.50	29.04	10.64	12.54
Castlereagh	31.5	79	35.65	11.08	9.23	23.06	8.10	9.38	10.93	10.93	27.27	10.12	11.66
Coolkeeragh	31.5	79	35.3	10.27	8.54	21.16	7.65	8.96	11.46	9.62	24.14	9.08	10.86
Hannahstown	31.5	79	35.65	11.02	8.98	22.42	7.90	9.11	11.14	10.75	26.90	9.97	11.57
Kells	31.5	79	35.65	12.76	10.36	26.30	9.04	11.08	11.70	12.25	30.81	11.33	13.36
Kilroot	31.5	79	45.3	11.43	8.98	22.53	7.93	9.21	12.07	11.35	28.65	10.52	12.35
Magherafelt	31.5	79	35.65	12.03	10.56	26.63	9.23	10.99	9.61	11.00	27.02	10.27	11.19
Moyle	31.5	79	35.65	11.43	8.98	22.53	7.93	9.21	12.07	11.35	28.65	10.52	12.35
Tandragee	31.5	79	35.65	11.27	11.14	27.89	9.72	11.33	10.58	12.78	31.77	11.82	13.57
Tamnamore	40	100	45.6	11.28	10.50	26.31	9.21	10.72	11.15	11.42	28.57	10.64	12.54
110kV													
Aghyoule	40	100		3.00	2.97	5.79	2.88	2.88	3.97	3.26	6.82	3.20	3.20
Antrim	40	100		4.97	8.22	18.09	7.73	7.93	5.03	8.59	18.95	8.34	8.75
Ballylumford	21.9	55	25.88	7.24	11.27	26.57	10.44	12.09					
	26.2	65	29.7						8.09	14.11	33.84	13.45	15.86
Ballymena	40	100		4.96	7.74	17.02	7.31	7.47	5.48	8.37	18.77	8.12	8.61
Banbridge	18.4	46.8		4.31	5.75	12.27	5.52	5.57	5.23	5.90	13.11	5.77	6.02
Ballyvallyagh	40	100	45.6	5.32	10.58	23.61	9.84	9.96	4.96	10.98	24.16	10.58	10.69
Ballynahinch	18.4	46.8		4.29	5.06	10.78	4.84	4.90	5.04	5.26	11.62	5.13	5.36
Belfast Central	31.5	79		8.49	11.08	26.78	10.16	11.05	5.46	13.99	31.38	13.20	14.13
Belfast North	18.4	46.8		4.89	11.61	25.47	10.72	10.87	3.14	12.39	24.48	11.89	12.70
Brockabhoy	40	100	45.6	4.95	3.51	7.72	3.39	3.42	4.26	2.91	6.18	2.87	2.88
Carmoney	31.5	79	45	4.14	6.91	14.62	6.56	6.63	4.66	7.33	15.91	7.12	7.37
Castlereagh	31.5	79	45	11.45	13.26	33.26	11.98	14.62	12.11	17.69	44.65	16.46	20.12
Coleraine	40	100	45.6	3.89	6.48	13.49	6.09	6.10	4.47	7.82	16.82	7.54	7.58
Coolkeeragh	31.5	80	33.5	10.62	14.90	37.07	13.48	16.68	11.19	19.52	48.85	18.35	22.74
Creagh	31.5	80	33.5	3.73	6.96	14.34	6.62	6.62	4.49	7.59	16.34	7.39	7.45
Cregagh	26.2	65		9.49	12.17	29.84	11.07	12.51	7.45	15.74	37.29	14.75	16.25
Donegall North	31.5	79	33.5	8.48	13.19	31.86	12.06	13.10	5.60	16.76	37.78	15.84	16.61
Donegall South				6.09	10.55	24.16	9.81	10.03	4.98	11.85	26.08	11.37	11.68

Table E-8 Northern Ireland Short Circuit Currents for Minimum Demand in 2019

Node	Rating			Three Phase					Single Phase				
	RMS	Peak	Asym	X/R	I''	ip	IB	asym B	X/R	I''	ip	IB	asym B
	[kA]	[kA]	[kA]	ratio	[kA]	[kA]	[kA]	[kA]	ratio	[kA]	[kA]	[kA]	[kA]
Curraghamulkin	40	100	45.6	4.67	4.56	9.90	4.40	4.41	5.19	4.87	10.81	4.77	4.87
Drumnakelly	31.5	79	42.5	8.88	13.32	32.38	12.19	13.40	8.73	15.36	37.25	14.58	16.13
Dungannon	40	100	45.6	7.42	10.60	25.10	9.88	10.56	7.34	12.16	28.74	11.67	12.61
Eden	25	62.5	45	4.20	7.24	15.36	6.86	6.93	4.63	7.70	16.69	7.48	7.69
Enniskillen	31.5	79	33.5	3.68	5.92	12.17	5.63	5.63	4.29	7.52	16.03	7.26	7.27
Finaghy	31.5	79		9.71	13.65	33.58	12.45	14.01	6.88	17.84	41.72	16.80	17.94
Glengormley	18.4	46.8		3.44	4.88	9.86	4.70	4.70	4.14	4.93	10.42	4.84	4.89
Gort Cluster	40	100	45.6	6.26	6.21	14.29	5.95	6.04	6.04	6.32	14.46	6.18	6.56
Hannahstown	31.5	80	33.5	11.17	14.90	37.27	13.49	16.06	11.69	19.86	49.95	18.59	22.24
Kells	31.5	79	45	10.17	14.68	36.33	13.32	16.32	10.65	19.04	47.36	17.90	21.94
Killymallaght	40	100	45	6.07	9.22	21.09	8.65	8.81	5.72	9.51	21.51	9.21	9.56
Knock	18.4	46.8		5.30	11.69	26.06	10.68	10.89	3.32	12.96	25.99	12.30	13.09
Larne	18.4	46.8	42.5	4.56	7.23	15.63	6.86	6.90	5.16	7.45	16.51	7.25	7.44
Limavady	18.4	46.8	23	3.67	5.89	12.11	5.60	5.60	4.33	6.65	14.20	6.46	6.51
Lisburn	18.4	46.8	23	5.58	10.49	23.63	9.75	9.93	4.97	10.81	23.78	10.42	10.81
Lisaghmore	31.5	79		4.77	8.12	17.72	7.66	7.77	4.94	8.38	18.41	8.14	8.46
Loguestown	26.2	65		3.54	4.86	9.89	4.63	4.63	4.12	5.52	11.65	5.37	5.39
Magherakeel Cluster	40	100	45	4.32	3.12	6.65	3.05	3.05	5.42	3.72	8.33	3.67	3.69
Newtownards	40	100		4.80	6.75	14.74	6.38	6.46	5.77	6.75	15.30	6.55	6.83
Newry	18.4	46.8	23	4.13	4.95	10.45	4.75	4.80	5.04	5.09	11.23	4.98	5.19
Omagh	40	100	42.5	4.91	9.61	21.09	8.96	9.03	5.14	11.24	24.91	10.77	11.00
Omagh South	40	100	42.5	4.04	7.39	15.54	6.98	6.99	4.16	8.33	17.63	8.05	8.06
Rasharkin	40	100	45.6	4.34	5.98	12.79	5.65	5.70	4.85	6.10	13.34	5.94	6.15
Rathgael	26.2	65		4.33	5.38	11.50	5.14	5.19	5.03	5.56	12.27	5.42	5.64
Rosebank	40	100		10.36	12.47	30.93	11.33	13.19	11.32	16.37	41.01	15.31	18.15
Slieve Kirk	40	100		4.54	6.92	14.93	6.59	6.61	5.35	6.27	13.99	6.14	6.36
Springtown	31.5	79	33.6	5.01	8.29	18.28	7.81	7.97	5.12	8.71	19.27	8.46	8.81
Strabane	18.4	46.8	23	5.33	10.88	24.29	10.09	10.21	5.86	12.66	28.77	12.12	12.53
Tandragee	31.5	79	33.5	11.57	15.10	37.93	13.70	16.72	12.46	19.05	48.22	17.89	22.08
Tamnamore	40	100	45	10.45	13.21	32.80	12.16	14.99	11.28	17.61	44.12	16.66	20.76
Tremoge Cluster	40	100	45.6	4.45	6.84	14.70	6.51	6.54	4.73	6.96	15.15	6.79	6.97
Waringstown	18.4	46.8		5.47	7.14	16.01	6.77	6.93	5.97	7.18	16.37	6.99	7.38

Table E-9 Northern Ireland Short Circuit Currents for Maximum Demand in 2019

Node	Rating			Three Phase					Single Phase				
	RMS	Peak	Asym	X/R	I''	ip	IB	asym B	X/R	I''	ip	IB	asym B
	[kA]	[kA]	[kA]	ratio	[kA]	[kA]	[kA]	[kA]	ratio	[kA]	[kA]	[kA]	[kA]
400 kV													
Turleenan	50	125	57.3	12.51	9.81	24.84	9.06	10.35	11.96	10.96	27.63	10.51	12.05
275kV													
Ballylumford	31.5	79	35.65	15.23	20.76	53.57	18.24	23.99	16.30	23.43	60.81	21.90	28.92
CAES	50	125	57.3	14.75	20.40	52.51	17.96	23.28	14.95	23.04	59.36	21.56	27.58
Castlereagh	31.5	79	35.65	10.93	16.99	42.41	14.99	17.28	10.78	17.43	43.42	16.33	18.80
Coolkeeragh	31.5	79	35.3	8.55	12.91	31.22	11.87	13.16	10.26	13.01	32.23	12.54	14.47
Hannahstown	31.5	79	35.65	11.29	16.92	42.40	14.96	17.41	11.35	17.53	43.93	16.44	19.35
Kells	31.5	79	35.65	12.98	19.52	49.63	17.27	20.94	11.31	19.88	49.80	18.77	21.72
Kilroot	31.5	79	45.3	14.89	20.26	52.19	17.84	23.17	15.73	22.71	58.76	21.26	27.58
Magherafelt	31.5	79	35.65	11.67	19.17	48.19	17.07	19.78	8.77	16.52	40.09	15.76	16.69
Moyle	31.5	79	35.65	14.89	20.26	52.19	17.84	23.17	15.73	22.71	58.76	21.26	27.58
Tandragee	31.5	79	35.65	10.59	19.56	48.64	17.30	19.57	9.92	19.66	48.51	18.49	20.78
Tamnamore	40	100	45.6	10.79	18.54	46.21	16.52	18.70	10.75	17.66	44.00	16.75	19.54
Turleenan	40	100	45.6	10.74	18.48	46.02	16.47	18.60	10.14	17.39	43.01	16.50	18.68
110kV													
Aghyoule	40	100		3.65	4.62	9.48	4.12	4.24	5.09	4.28	9.45	4.10	4.40
Airport Road	40	100		4.74	11.32	24.65	10.53	10.67	4.94	11.43	25.11	10.96	11.33
Antrim	40	100		4.22	10.51	22.31	9.99	10.13	4.48	10.25	22.05	10.01	10.38
Ballylumford	21.9	55	25.88	10.60	24.35	60.56	22.38	29.21					
	26.2	65	29.7						12.31	28.07	70.98	26.85	35.65
Ballymena	40	100		4.42	10.09	21.65	9.57	9.76	5.06	10.29	22.72	10.03	10.66
Banbridge	18.4	46.8		3.96	6.77	14.17	6.50	6.54	4.96	6.62	14.57	6.47	6.73
Ballyvallyagh	40	100	45.6	4.50	17.03	36.68	15.92	15.97	4.39	15.25	32.68	14.83	14.90
Ballynahinch	18.4	46.8		3.86	6.08	12.65	5.79	5.84	4.71	6.00	13.05	5.82	6.07
Belfast Central	31.5	79		7.25	15.97	37.68	14.47	15.50	4.59	18.99	41.09	17.73	18.75
Belfast North	18.4	46.8		4.23	15.68	33.31	14.55	14.66	2.72	15.33	29.16	14.73	15.63
Brockabhoy	40	100	45	5.93	6.05	13.79	4.84	4.98	5.63	4.15	9.36	3.90	4.03
Carmoney	31.5	79	45	3.57	9.19	18.75	8.76	8.82	4.24	8.91	18.94	8.69	8.93
Castlereagh	31.5	79	45	10.05	20.52	50.71	18.20	22.60	11.13	26.15	65.41	23.94	29.80
Coleraine	40	100	45.6	4.13	10.30	21.76	9.36	9.41	4.90	10.98	24.09	10.50	10.70

Table E-9 Northern Ireland Short Circuit Currents for Maximum Demand in 2019

Node	Rating			Three Phase					Single Phase				
	RMS	Peak	Asym	X/R	I''	ip	IB	asym B	X/R	I''	ip	IB	asym B
	[kA]	[kA]	[kA]	ratio	[kA]	[kA]	[kA]	[kA]	ratio	[kA]	[kA]	[kA]	[kA]
Coolkeeragh	31.5	80	33.5	8.96	24.13	58.74	21.78	26.11	9.98	29.43	72.64	27.88	33.78
Creagh	31.5	80	33.5	3.28	8.65	17.28	8.27	8.27	4.15	8.85	18.72	8.64	8.70
Cregagh	26.2	65		8.11	18.17	43.62	16.28	18.20	6.33	22.23	51.24	20.56	22.36
Donegall North	31.5	79	33.5	7.84	18.52	44.22	16.99	18.28	4.92	22.29	48.94	21.06	21.87
Donegall South				5.47	13.93	31.25	13.02	13.22	4.51	14.64	31.55	14.08	14.37
Dromore	40	100	45	5.26	6.99	15.56	6.42	6.55	5.71	6.35	14.36	6.16	6.62
Drumnakelly	31.5	79	42.5	7.98	18.34	43.91	16.74	18.09	8.05	19.63	47.05	18.59	20.31
Dungannon	40	100	45.6	6.48	14.85	34.37	13.86	14.51	6.64	15.68	36.45	15.12	16.10
Eden	25	62.5	45	3.65	10.33	21.20	9.86	9.90	4.24	9.87	20.98	9.65	9.85
Enniskillen	31.5	79	33.5	3.62	11.54	23.63	9.27	9.30	4.70	11.78	25.61	10.72	10.85
Finaghy	31.5	79		9.24	19.36	47.32	17.72	19.94	6.20	24.12	55.40	22.72	24.01
Garvagh Cluster	40	100	45	5.83	6.53	14.82	5.37	5.54	6.23	4.99	11.47	4.70	5.00
Glengormley	18.4	46.8		3.11	5.84	11.51	5.64	5.64	3.90	5.58	11.63	5.49	5.54
Gort Cluster	40	100	45	6.51	8.81	20.41	8.30	8.52	6.02	7.96	18.20	7.80	8.46
Hannahstown	31.5	80	33.5	11.07	21.76	54.39	19.75	24.07	11.85	27.72	69.80	25.93	31.86
Kells	31.5	79	33.5	8.47	22.88	55.26	20.87	25.02	9.30	28.14	68.83	26.70	32.30
Killymallaght	40	100	45	5.68	13.54	30.58	12.70	12.99	5.35	12.27	27.40	11.98	12.45
Knock	18.4	46.8		4.22	17.06	36.24	15.38	15.53	2.75	16.98	32.39	16.00	16.85
Larne	18.4	46.8	42.5	4.01	10.07	21.13	9.62	9.64	4.79	9.32	20.36	9.14	9.33
Limavady	18.4	46.8	23	3.60	8.35	17.07	7.82	7.83	4.43	8.51	18.26	8.26	8.37
Lisburn	18.4	46.8	23	4.90	13.54	29.70	12.68	12.82	4.52	12.97	27.96	12.55	12.92
Lisaghmore	31.5	79		4.11	10.72	22.62	10.16	10.25	4.48	10.17	21.88	9.95	10.25
Loguestown	26.2	65		3.57	6.89	14.06	6.43	6.44	4.31	7.03	14.99	6.80	6.89
Magherakeel Cluster	40	100	45	5.23	4.48	9.97	4.41	4.58	6.92	4.89	11.45	4.86	5.24
Newtownards	40	100		4.22	8.50	18.04	8.01	8.08	5.33	7.91	17.66	7.67	7.94
Newry	18.4	46.8	23	3.99	5.86	12.27	5.56	5.67	4.96	5.67	12.48	5.52	5.84
Omagh	40	100	42.5	4.75	17.13	37.34	15.25	15.50	5.12	16.89	37.39	16.09	16.74
Omagh South	40	100	42.5	3.94	13.20	27.57	11.44	11.52	4.15	12.09	25.56	11.45	11.52
Rasharkin	40	100	42.5	4.75	9.64	21.02	8.53	8.69	5.07	8.46	18.68	8.10	8.45

Table E-9 Northern Ireland Short Circuit Currents for Maximum Demand in 2019

Node	Rating			Three Phase					Single Phase				
	RMS	Peak	Asym	X/R	I''	ip	IB	asym B	X/R	I''	ip	IB	asym B
	[kA]	[kA]	[kA]	ratio	[kA]	[kA]	[kA]	[kA]	ratio	[kA]	[kA]	[kA]	[kA]
Rathgael	26.2	65		3.89	6.53	13.61	6.20	6.25	4.69	6.36	13.83	6.18	6.41
Rosebank	40	100		9.00	18.82	45.84	16.83	19.58	10.35	23.51	58.29	21.69	25.77
Slieve Kirk	40	100		4.36	9.52	20.35	9.09	9.17	5.35	7.61	17.00	7.50	8.00
Springtown	31.5	79	33.6	4.33	11.02	23.52	10.46	10.59	4.61	10.65	23.07	10.43	10.78
Strabane	18.4	46.8	23	4.59	17.04	36.87	15.65	15.75	5.39	17.63	39.43	16.98	17.55
Tandragee	31.5	79	33.5	10.77	21.51	53.61	19.45	23.73	12.04	25.59	64.55	23.94	29.75
Tamnamore	40	100	45	9.30	19.80	48.44	18.32	22.17	10.41	25.10	62.29	23.95	29.49
Tremoge Cluster	40	100	42.5	4.26	9.60	20.44	9.16	9.22	4.60	8.65	18.73	8.50	8.82
Waringstown	18.4	46.8		4.99	8.64	19.02	8.20	8.33	5.63	8.25	18.60	8.02	8.42

Table E-10 Northern Ireland Short Circuit Currents for Minimum Demand in 2022

Node	Rating			Three Phase					Single Phase				
	RMS	Peak	Asym	X/R	I''	ip	IB	asym B	X/R	I''	ip	IB	asym B
	[kA]	[kA]	[kA]	ratio	[kA]	[kA]	[kA]	[kA]	ratio	[kA]	[kA]	[kA]	[kA]
400 kV													
Turleenan	50	125	57.3	12.83	7.30	18.54	6.44	7.75	11.79	8.63	21.73	7.99	9.46
275kV													
Ballylumford	31.5	79	35.65	11.27	8.99	22.52	7.90	9.20	11.98	11.62	29.30	10.65	12.58
CAES	50	125	57.3	11.14	8.91	22.29	7.83	9.08	11.54	11.50	28.89	10.55	12.30
Castlereagh	31.5	79	35.65	11.07	9.15	22.86	7.99	9.30	10.94	10.89	27.17	10.00	11.58
Coolkeeragh	31.5	79	35.3	14.46	8.99	23.10	8.00	10.07	15.01	9.95	25.65	9.34	11.88
Hannahstown	31.5	79	35.65	10.97	8.91	22.24	7.80	9.03	11.08	10.71	26.77	9.85	11.48
Kells	31.5	79	35.65	12.19	9.90	25.02	8.64	10.42	11.34	11.85	29.69	10.89	12.74
Kilroot	31.5	79	45.3	11.24	8.91	22.30	7.83	9.11	11.90	11.46	28.86	10.51	12.37
Magherafelt	31.5	79	35.65	12.83	10.93	27.75	9.49	11.69	9.86	11.40	28.09	10.56	11.63
Moyle	31.5	79	35.65	11.24	8.91	22.30	7.83	9.11	11.90	11.46	28.86	10.51	12.37
Tandragee	31.5	79	35.65	11.70	11.37	28.59	9.83	11.75	10.75	13.19	32.85	12.06	14.04
Tamnamore	40	100	45.6	12.19	11.33	28.63	9.82	11.89	11.41	12.65	31.72	11.63	14.06
Turleenan	40	100	45.6	12.20	11.50	29.05	9.96	12.06	10.90	12.77	31.85	11.73	13.85
110kV													
Aghyoule	40	100		3.00	3.00	5.85	2.90	2.90	3.97	3.30	6.90	3.23	3.24
Airport Road	40	100		5.52	8.75	19.67	8.14	8.31	5.49	9.50	21.32	9.10	9.49
Antrim	40	100		4.80	8.23	17.97	7.74	7.89	4.87	8.60	18.83	8.33	8.67
Ballylumford	40	100	45.6	9.02	13.50	32.90	12.35	14.73	9.97	17.28	42.64	16.28	19.76
Ballymena	40	100		4.85	7.80	17.08	7.36	7.52	5.35	8.40	18.77	8.14	8.62
Banbridge	18.4	46.8		4.32	5.86	12.51	5.61	5.66	5.25	6.01	13.37	5.87	6.13
Ballyvallyagh	40	100	45.6	5.33	11.36	25.35	10.50	10.61	4.91	11.61	25.49	11.14	11.24
Ballynahinch	18.4	46.8		4.25	5.15	10.96	4.91	4.97	5.00	5.34	11.76	5.19	5.42
Belfast Central	31.5	79		8.43	11.39	27.49	10.37	11.31	5.37	14.36	32.11	13.47	14.41
Belfast North	18.4	46.8		4.90	11.72	25.72	10.78	10.93	3.11	12.50	24.65	11.93	12.75
Brockabhoy	40	100	42.5	4.95	3.29	7.24	3.19	3.21	5.30	3.35	7.46	3.30	3.36
Carmoney	31.5	79	45	4.09	7.23	15.23	6.83	6.90	4.61	7.57	16.38	7.33	7.57
Castlereagh	40	100	45.6	11.38	13.65	34.23	12.24	15.06	12.07	18.25	46.05	16.86	20.75
Coleraine	40	100	45.6	3.86	6.73	13.99	6.32	6.33	4.42	8.08	17.33	7.78	7.82
Coolkeeragh	31.5	80	33.5	12.63	16.59	42.05	14.82	19.56	13.14	21.35	54.36	19.95	26.13

Table E-10 Northern Ireland Short Circuit Currents for Minimum Demand in 2022

Node	Rating			Three Phase					Single Phase				
	RMS	Peak	Asym	X/R	I''	ip	IB	asym B	X/R	I''	ip	IB	asym B
	[kA]	[kA]	[kA]	ratio	[kA]	[kA]	[kA]	[kA]	ratio	[kA]	[kA]	[kA]	[kA]
Creagh	31.5	80	33.5	3.71	7.06	14.55	6.71	6.71	4.47	7.67	16.50	7.45	7.52
Cregagh	26.2	65		9.43	12.52	30.67	11.31	12.84	7.33	16.19	38.26	15.07	16.61
Donegall North	31.5	79	33.5	8.46	13.30	32.12	12.11	13.17	5.58	16.87	37.99	15.85	16.60
Donegall South				6.09	10.67	24.42	9.88	10.10	4.97	11.97	26.33	11.44	11.74
Curraghmulkin	40	100	42.5	4.66	4.62	10.03	4.45	4.46	5.19	4.90	10.87	4.79	4.90
Drumnakelly	31.5	79	42.5	9.03	13.58	33.10	12.38	13.71	8.80	15.60	37.89	14.73	16.38
Dungannon	40	100	45.6	7.51	10.88	25.82	10.12	10.90	7.38	12.41	29.35	11.87	12.89
Eden	25	62.5	45	4.19	7.79	16.51	7.35	7.40	4.60	8.13	17.61	7.88	8.08
Enniskillen	31.5	79	33.5	3.69	6.07	12.48	5.75	5.75	4.31	7.67	16.36	7.38	7.39
Finaghy	31.5	79		9.68	13.76	33.84	12.50	14.09	6.88	17.95	41.97	16.80	17.95
Garvagh Cluster	40	100	42.5	4.85	3.66	8.02	3.54	3.56	5.67	3.96	8.95	3.89	4.01
Glengormley	18.4	46.8		3.42	4.95	10.00	4.76	4.77	4.11	4.99	10.54	4.89	4.95
Gort Cluster	40	100	42.5	6.24	6.33	14.56	6.06	6.16	6.07	6.42	14.69	6.27	6.66
Hannahstown	31.5	80	33.5	11.10	15.00	37.50	13.52	16.13	11.65	19.96	50.17	18.57	22.28
Kells	40	100	45.6	9.47	14.70	36.05	13.32	16.07	9.99	19.08	47.11	17.87	21.64
Killymallaght	40	100	45	6.20	9.76	22.41	9.11	9.27	5.77	9.88	22.40	9.56	9.92
Knock	18.4	46.8		5.25	12.01	26.74	10.89	11.11	3.25	13.28	26.47	12.53	13.31
Larne	18.4	46.8	42.5	4.53	7.64	16.47	7.23	7.25	5.12	7.73	17.11	7.51	7.70
Limavady	18.4	46.8	23	3.65	6.14	12.60	5.83	5.83	4.31	6.86	14.65	6.67	6.71
Lisburn	18.4	46.8	23	5.59	10.63	23.94	9.83	10.02	4.98	10.95	24.11	10.51	10.91
Lisaghmore	31.5	79		4.82	8.67	18.95	8.14	8.25	4.96	8.77	19.29	8.51	8.84
Loguestown	26.2	65		3.51	5.02	10.19	4.78	4.78	4.10	5.65	11.92	5.50	5.53
Magherakeel Cluster	40	100	45	4.30	3.13	6.68	3.06	3.06	5.39	3.74	8.37	3.69	3.71
Newtownards	40	100		4.77	6.90	15.04	6.49	6.57	5.70	6.86	15.51	6.64	6.91
Newry	18.4	46.8	23	4.10	5.01	10.56	4.80	4.85	5.00	5.12	11.27	5.00	5.21
Omagh	40	100	42.5	4.86	10.01	21.93	9.32	9.38	5.11	11.58	25.63	11.07	11.30
Omagh South	40	100	42.5	4.02	7.60	15.96	7.17	7.18	4.15	8.48	17.93	8.18	8.19
Rasharkin	40	100	42.5	4.30	6.14	13.09	5.79	5.84	4.80	6.63	14.49	6.45	6.60
Rathgael	26.2	65		4.30	5.49	11.70	5.22	5.27	4.98	5.63	12.40	5.48	5.70
Rosebank	40	100		10.33	12.85	31.87	11.59	13.60	11.23	16.88	42.27	15.68	18.65
Slieve Kirk	40	100		4.56	7.24	15.63	6.87	6.89	5.35	6.42	14.34	6.28	6.52

Table E-10 Northern Ireland Short Circuit Currents for Minimum Demand in 2022

Node	Rating			Three Phase					Single Phase				
	RMS	Peak	Asym	X/R	I''	ip	IB	asym B	X/R	I''	ip	IB	asym B
	[kA]	[kA]	[kA]	ratio	[kA]	[kA]	[kA]	[kA]	ratio	[kA]	[kA]	[kA]	[kA]
Springtown	31.5	79	33.6	5.07	8.86	19.58	8.31	8.46	5.14	9.13	20.23	8.85	9.22
Strabane	18.4	46.8	23	5.39	11.52	25.77	10.63	10.74	5.92	13.22	30.10	12.62	13.05
Tandragee	40	100	45.6	11.86	15.41	38.81	13.91	17.26	12.76	19.40	49.24	18.11	22.69
Tamnamore	40	100	45	10.75	13.61	33.89	12.49	15.77	11.61	18.09	45.46	17.04	21.73
Torr Head	40	100	42.5	5.93	2.33	5.30	2.29	2.31	5.96	3.40	7.75	3.36	3.39
Tremoge Cluster	40	100	42.5	4.35	6.88	14.71	6.56	6.58	4.65	6.98	15.15	6.81	6.96
Waringstown	18.4	46.8		5.49	7.27	16.32	6.88	7.04	5.99	7.30	16.66	7.09	7.49

Table E-11 Northern Ireland Short Circuit Currents for Maximum Demand in 2022

Node	Rating			Three Phase					Single Phase				
	RMS	Peak	Asym	X/R	I''	ip	IB	asym B	X/R	I''	ip	IB	asym B
	[kA]	[kA]	[kA]	ratio	[kA]	[kA]	[kA]	[kA]	ratio	[kA]	[kA]	[kA]	[kA]
400 kV													
Turleenan	50	125	57.3	12.82	12.18	30.94	11.32	12.95	11.39	12.81	32.13	12.36	14.15
275kV													
Ballylumford	31.5	79	35.65	15.47	22.15	57.25	19.82	25.60	16.56	24.53	63.74	23.19	30.31
CAES	50	125	57.3	14.91	21.74	55.98	19.48	24.78	15.06	24.09	62.10	22.80	28.82
Castlereagh	31.5	79	35.65	10.96	18.01	44.97	16.16	18.39	10.77	17.98	44.80	17.02	19.45
Coolkeeragh	31.5	79	35.3	13.17	13.67	34.82	12.75	14.99	14.28	13.46	34.54	13.08	15.97
Hannahstown	31.5	79	35.65	11.31	17.86	44.76	16.06	18.42	11.33	18.04	45.21	17.10	19.95
Kells	31.5	79	35.65	13.46	21.03	53.65	19.01	22.78	11.24	20.80	52.07	19.88	22.82
Kilroot	31.5	79	45.3	15.09	21.58	55.63	19.35	24.67	15.91	23.71	61.42	22.46	28.81
Magherafelt	31.5	79	35.65	12.60	21.32	54.05	19.34	22.61	8.76	17.42	42.28	16.79	17.74
Moyle	31.5	79	35.65	15.09	21.58	55.63	19.35	24.67	15.91	23.71	61.42	22.46	28.81
Tandragee	31.5	79	35.65	11.18	21.96	54.94	19.68	22.34	10.00	21.17	52.28	20.12	22.60
Tamnamore	40	100	45.6	11.58	21.65	54.39	19.58	22.35	10.71	19.73	49.12	18.90	22.13
Turleenan	40	100	45.6	11.58	21.92	55.07	19.80	22.60	10.03	19.82	48.97	18.98	21.55
110kV													
Aghyoule	40	100		3.79	4.60	9.52	4.10	4.24	5.25	4.32	9.61	4.14	4.48
Airport Road	40	100		4.71	11.21	24.38	10.50	10.64	4.98	11.31	24.90	10.88	11.30
Antrim	40	100		4.14	10.78	22.78	10.41	10.53	4.44	10.34	22.21	10.18	10.54
Ballylumford	40	100	45.6	10.40	24.95	61.91	23.23	30.05	12.17	28.55	72.10	27.50	36.33
Ballymena	40	100		4.35	10.35	22.12	9.96	10.14	5.05	10.40	22.96	10.22	10.84
Banbridge	18.4	46.8		3.97	6.66	13.94	6.43	6.47	5.00	6.53	14.39	6.41	6.66
Ballyvallyagh	40	100	45.6	4.35	17.42	37.24	16.54	16.57	4.32	15.38	32.83	15.05	15.11
Ballynahinch	18.4	46.8		3.89	5.96	12.41	5.68	5.74	4.77	5.90	12.87	5.74	5.98
Belfast Central	31.5	79		7.14	16.05	37.75	14.64	15.62	4.54	18.94	40.89	17.76	18.85
Belfast North	18.4	46.8		4.15	15.68	33.17	14.67	14.78	2.74	15.18	28.93	14.66	15.58
Brockabhoy	40	100	45.6	5.90	5.99	13.63	4.83	4.96	5.61	4.13	9.31	3.89	4.01
Carmoney	31.5	79	45	3.58	9.09	18.55	8.72	8.78	4.28	8.85	18.85	8.65	8.91
Castlereagh	40	100	45.6	9.94	20.94	51.68	18.70	23.11	10.89	26.58	66.30	24.42	30.22
Coleraine	40	100	45.6	4.11	10.17	21.46	9.27	9.32	4.88	10.90	23.90	10.43	10.63
Coolkeeragh	31.5	80	33.5	9.86	24.62	60.69	22.42	28.07	10.85	29.89	74.55	28.48	35.81

Table E-11 Northern Ireland Short Circuit Currents for Maximum Demand in 2022

Node	Rating			Three Phase					Single Phase				
	RMS	Peak	Asym	X/R	I''	ip	IB	asym B	X/R	I''	ip	IB	asym B
	[kA]	[kA]	[kA]	ratio	[kA]	[kA]	[kA]	[kA]	ratio	[kA]	[kA]	[kA]	[kA]
Creagh	31.5	80	33.5	3.23	8.65	17.20	8.35	8.35	4.12	8.86	18.72	8.69	8.74
Cregagh	26.2	65		7.99	18.39	44.05	16.60	18.46	6.23	22.37	51.43	20.77	22.61
Donegall North	31.5	79	33.5	7.74	18.63	44.41	17.26	18.48	4.87	22.30	48.86	21.20	22.01
Donegall South				5.39	13.88	31.04	13.08	13.25	4.48	14.50	31.21	14.02	14.30
Curraghmulkin	40	100	45.6	5.29	6.87	15.31	6.32	6.47	5.82	6.29	14.27	6.12	6.60
Drumnakelly	31.5	79	42.5	8.09	18.49	44.36	17.12	18.47	8.12	19.58	47.00	18.72	20.46
Dungannon	40	100	45.6	6.49	14.93	34.56	14.06	14.71	6.68	15.68	36.48	15.20	16.21
Eden	25	62.5	45	3.63	10.25	21.01	9.85	9.89	4.25	9.82	20.88	9.63	9.83
Enniskillen	31.5	79	33.5	3.60	11.46	23.44	9.19	9.21	4.67	11.66	25.31	10.62	10.74
Finaghy	31.5	79		9.16	19.51	47.64	18.03	20.15	6.11	24.20	55.42	22.93	24.21
Garvagh Cluster				5.79	6.46	14.65	5.35	5.51	6.21	4.96	11.39	4.68	4.98
Glengormley	18.4	46.8		3.06	5.85	11.48	5.70	5.70	3.89	5.58	11.62	5.51	5.55
Gort Cluster				6.53	8.68	20.12	8.22	8.44	6.18	7.91	18.15	7.76	8.46
Hannahstown	31.5	80	33.5	11.03	22.05	55.08	20.22	24.46	11.78	27.96	70.36	26.32	32.16
Kells	40	100	45.6	8.71	25.00	60.61	23.52	27.73	9.07	30.27	73.82	29.19	34.97
Killymallaght	40	100	45	5.73	13.47	30.50	12.75	13.04	5.43	12.19	27.31	11.96	12.49
Knock	18.4	46.8		4.13	17.19	36.32	15.61	15.76	2.78	16.82	32.18	15.92	16.88
Larne	18.4	46.8	42.5	3.93	10.10	21.10	9.74	9.75	4.79	9.37	20.46	9.22	9.40
Limavady	18.4	46.8	23	3.59	8.22	16.81	7.73	7.74	4.44	8.44	18.13	8.21	8.31
Lisburn	18.4	46.8	23	4.84	13.49	29.52	12.74	12.87	4.52	12.84	27.68	12.48	12.87
Lisaghmore	31.5	79		4.15	10.59	22.41	10.10	10.19	4.53	10.03	21.64	9.84	10.16
Loguestown	26.2	65		3.56	6.79	13.85	6.35	6.36	4.30	6.98	14.88	6.76	6.84
Magherakeel Cluster	40	100	45	5.28	4.37	9.74	4.32	4.50	6.94	4.82	11.30	4.80	5.19
Newtownards	40	100		4.19	8.34	17.68	7.91	7.97	5.33	7.78	17.36	7.55	7.83
Newry	18.4	46.8	23	4.08	5.81	12.24	5.53	5.65	5.09	5.67	12.54	5.52	5.87
Omagh	40	100	42.5	4.70	17.03	37.03	15.27	15.50	5.10	16.79	37.15	16.07	16.72
Omagh South	40	100	42.5	3.90	13.07	27.25	11.38	11.45	4.11	11.92	25.17	11.34	11.40
Rasharkin				4.69	9.55	20.76	8.50	8.66	5.03	8.37	18.46	8.04	8.37
Rathgael	26.2	65		3.89	6.39	13.31	6.09	6.14	4.72	6.26	13.62	6.09	6.32
Rosebank	40	100		8.88	19.09	46.41	17.19	19.90	10.15	23.72	58.69	21.97	25.99
Slieve Kirk	40	100		4.37	9.38	20.07	9.03	9.10	5.41	7.53	16.85	7.44	7.92

Table E-11 Northern Ireland Short Circuit Currents for Maximum Demand in 2022

Node	Rating			Three Phase					Single Phase				
	RMS	Peak	Asym	X/R	I''	ip	IB	asym B	X/R	I''	ip	IB	asym B
	[kA]	[kA]	[kA]	ratio	[kA]	[kA]	[kA]	[kA]	ratio	[kA]	[kA]	[kA]	[kA]
Springtown	31.5	79	33.6	4.41	10.91	23.40	10.43	10.58	4.72	10.56	22.99	10.37	10.77
Strabane	18.4	46.8	23	4.54	17.16	37.04	15.94	16.03	5.38	17.67	39.52	17.13	17.68
Tandragee	40	100	45.6	11.22	21.97	54.99	20.13	24.74	12.43	25.87	65.47	24.45	30.56
Tamnamore	40	100	45	9.52	20.17	49.49	18.87	23.07	10.67	25.41	63.24	24.42	30.41
Torr Head				8.21	3.55	8.54	7.54	7.71	8.11	7.28	17.47	11.00	11.48
Tremoge Cluster				4.24	9.47	20.13	9.09	9.15	4.64	8.53	18.51	8.41	8.74
Waringstown	18.4	46.8		5.01	8.53	18.80	8.16	8.30	5.70	8.13	18.39	7.95	8.36



All-Island Ten Year

**Transmission Forecast
Statement** **2016**

Appendix F



Appendix F: Additional Information on Opportunities

F.1 EirGrid Approach to Consultation

In December 2016 EirGrid launched [Have Your Say](#)¹, which outlines our approach to consultation. It follows a review of our consultation activities, after which, we made a commitment to improve the way we engage with the public and stakeholders.

[Have Your Say](#) outlines the way we develop our projects and how the public can engage with us at each stage of project development.

Project Development Status

For the purposes of the TYTFS project status is categorised as pre-planning, planning and approved (In construction and complete are both subsets of approved). Each project status category is detailed below. We will continue to participate and encourage public engagement at each project status stage, as per our consultation strategy.

- (1) Pre-planning – the need for the project is identified and consideration of solutions are formulated
- (2) Planning – outline design of preferred solutions
- (3) Approved – detailed design of preferred solution and project agreement (PA) with transmission asset owner (TAO) agreed
 - 3.1 In construction – procurement and construction of transmission assets/works
 - 3.2 Complete – commissioning and energisation of assets/works

F.2 SONI Approach to Consultation

SONI is currently reviewing its approach to engaging and consulting with the public and stakeholders. Once this review is complete, we will provide further information about the way we intend to develop our projects and how the public can engage with us at each stage of project development. If you have any queries you can contact us at enquiries@soni.ltd.uk.

1. <http://www.eirgridgroup.com/the-grid/have-your-say/>



All-Island Ten Year

**Transmission Forecast
Statement** **2016**

Appendix G



Appendix G: References

The following documents are referenced in All-Island Ten Year Transmission Forecast Statement 2016:

- Electricity Regulation Act, 1999. This act provides the regulatory framework for the introduction of competition in the generation and supply of electricity in Ireland. The Act provided for the establishment of the Commission for Energy Regulation (CER) (previously called the Commission for Electricity Regulation) and gave it the necessary powers to licence and regulate the generation, distribution, transmission and supply of electricity. Available on www.cer.ie.
- The Utility Regulator Northern Ireland's powers are derived from the Electricity (Northern Ireland) Order 1992, as amended by the Energy (Northern Ireland) Order 2003. This Order provides the regulatory framework for the Electricity Sector in Northern Ireland.
- All-Island Generation Capacity Statement, 2016-2025. EirGrid and SONI issued this report in February 2016. Its main purpose is to inform market participants, regulatory agencies and policy makers of the likely minimum generation capacity required to achieve an adequate supply and demand balance for electricity for the period 2016 to 2025. Available on www.eirgridgroup.com.
- Draft Transmission Development Plan 2016 – For Public Consultation, 2016-2026. CER issued this report for public consultation in March 2017. Its main purpose is to document the plan for the development of the Irish transmission system and interconnection for the following 10 year period. Available on www.eirgridgroup.com.
- EirGrid Grid Code Version 6.0, July 2015. The EirGrid Grid Code covers technical aspects relating to the operation and use of the transmission system, and to plant and apparatus connected to the transmission system or to the distribution system. Available on www.eirgridgroup.com.
- The SONI Grid Code, August 2015. The SONI Grid Code is designed to permit the development, maintenance and operation of an efficient, co-ordinated and economical Transmission System in Northern Ireland. The grid code is prepared by the TSO (SONI) pursuant to condition 16 of SONI's Licence. The SONI Grid Code is available at www.soni.ltd.uk.
- Transmission System Security and Planning Standards Ireland, May 2016. This document sets out the technical standards by which the adequacy of the grid in Ireland is determined. Available on www.eirgridgroup.com.
- Transmission System Security and Planning Standards Northern Ireland, September 2015. This document sets out the technical standards by which the adequacy of the grid in Northern Ireland is determined. Available on www.soni.ltd.uk.
- Statutory Instrument no. 445. These Regulations give legal effect to Directive No. 96/92/EC of the European Parliament and of the Council of 19th December 1996, concerning common rules for the internal market in electricity, not already implemented by the Electricity Regulation Act, 1999, by providing for the designation of a Transmission System Operator, the designation of a Distribution System Operator, and the unbundling of the accounts of electricity undertakings, and other matters. Available on www.cer.ie.
- TSO Licence. On June 29th 2006, the CER issued a Transmission System Operator (TSO) Licence to EirGrid plc. pursuant to Section 14(1)(e) of the Electricity Regulation Act, 1999, as inserted by Regulation 32 of S.I. No. 445 of 2000 – European Communities (Internal Market in Electricity) Regulations 2001.
- Licence to Participate in the Transmission of Electricity, Updated to May 2012. Available on www.uregni.gov.uk. Condition 33 requires SONI to prepare a statement (in a form; in consultation with EirGrid; and based on methodologies approved by UREGNI) showing in respect of each of the seven succeeding financial years; circuit capacity; forecast electrical flows and loading on each part of the transmission system; and fault levels for each transmission node.

- Ireland's Transition to a Low Carbon Energy Future 2015-2030, December 2015. Government White Paper on energy policy out to 2030, published by the Department of Communications, Climate Action and Environment. Available on www.dccae.gov.ie.
- Strategic Energy Framework 2010-2020, September 2010. A Strategic Energy Framework for Northern Ireland. Available on www.economy-ni.gov.uk/.
- Treatment of Curtailment in Tie Break Situations. Single Electricity Market (SEM) decision paper (SEM-13-010) in relation to the treatment of curtailment in tie break situations. Available on www.semcommittee.com/.
- Operating Security Standards, March 2016. This document sets out the main standard that the transmission licensee (SONI ltd) shall use in the operation of the Northern Ireland transmission system. Available on www.soni.ltd.uk

All-Island Ten Year

**Transmission Forecast
Statement** **2016**

Appendix H

Appendix H: Power Flow Diagrams

This appendix presents power flow diagrams for the following cases:

- Figure H-1 Summer Night Valley 2016
- Figure H-2 Summer Peak 2016
- Figure H-3 Winter Peak 2016
- Figure H-4 Summer Night Valley 2025
- Figure H-5 Summer Peak 2025
- Figure H-6 Winter Peak 2025



Note that summer cases cover the period between May and August and winter cases cover the period between November and February. As such, the layout of the network in the power flow diagrams may not feature all projects listed in Appendix B for a particular year as these are listed on a yearly basis.

H.1 Guide to the Power Flow Diagrams

Different colours represent each of the voltage levels:

400 kV	red
275 kV	blue
220 kV	green
110 kV	black

Generation (>5MW) connected at each bus is shown beside a  symbol, with the generation dispatched in MW shown beside the symbol. Embedded generation is shown at the transmission bus to which it is connected through the distribution system.

The East–West interconnector is denoted by a  symbol and the Moyle interconnector is denoted by a  symbol. The magnitude of the power on the interconnectors is given beneath the symbol in MW.

There are two values shown at both ends of each circuit. The value above the line is the MW flow and the value below the line is the Mvar flow. A positive value indicates that the direction of flow is away from the bus; a negative value, towards the bus.

H-2

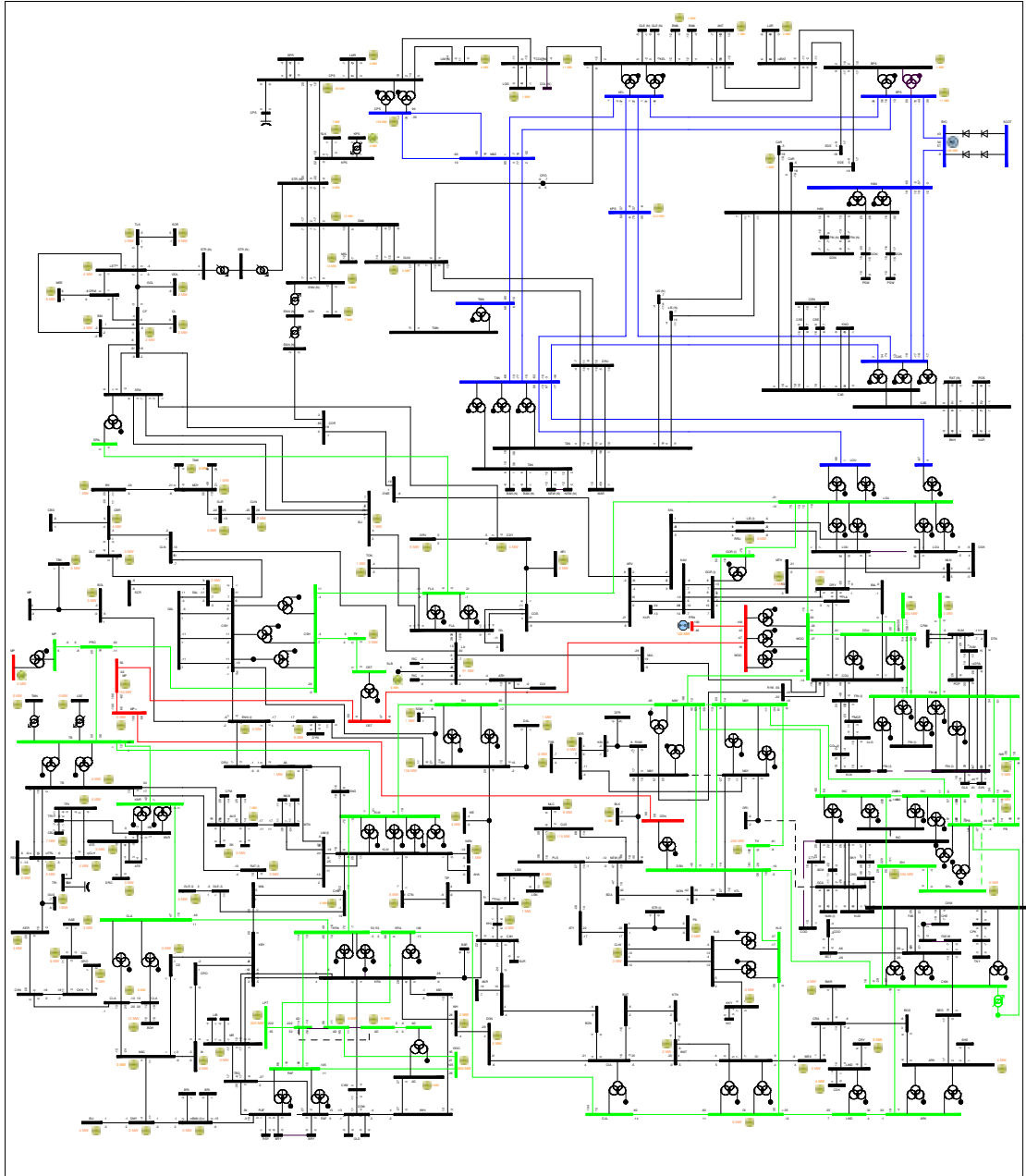

Figure H-1 Power Flow Diagram Summer Night Valley 2016

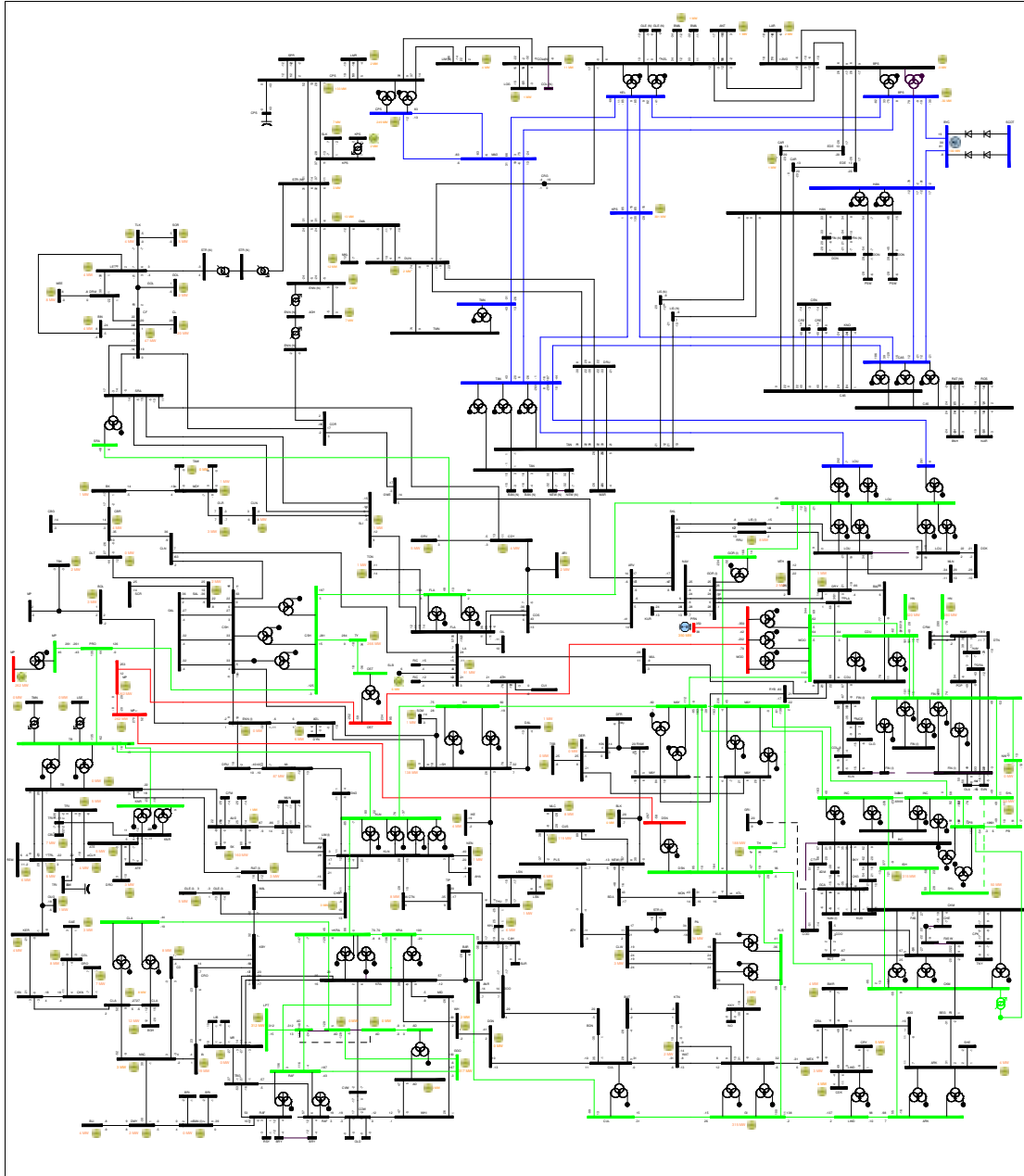

Figure H-2 Power Flow Diagram Summer Peak 2016

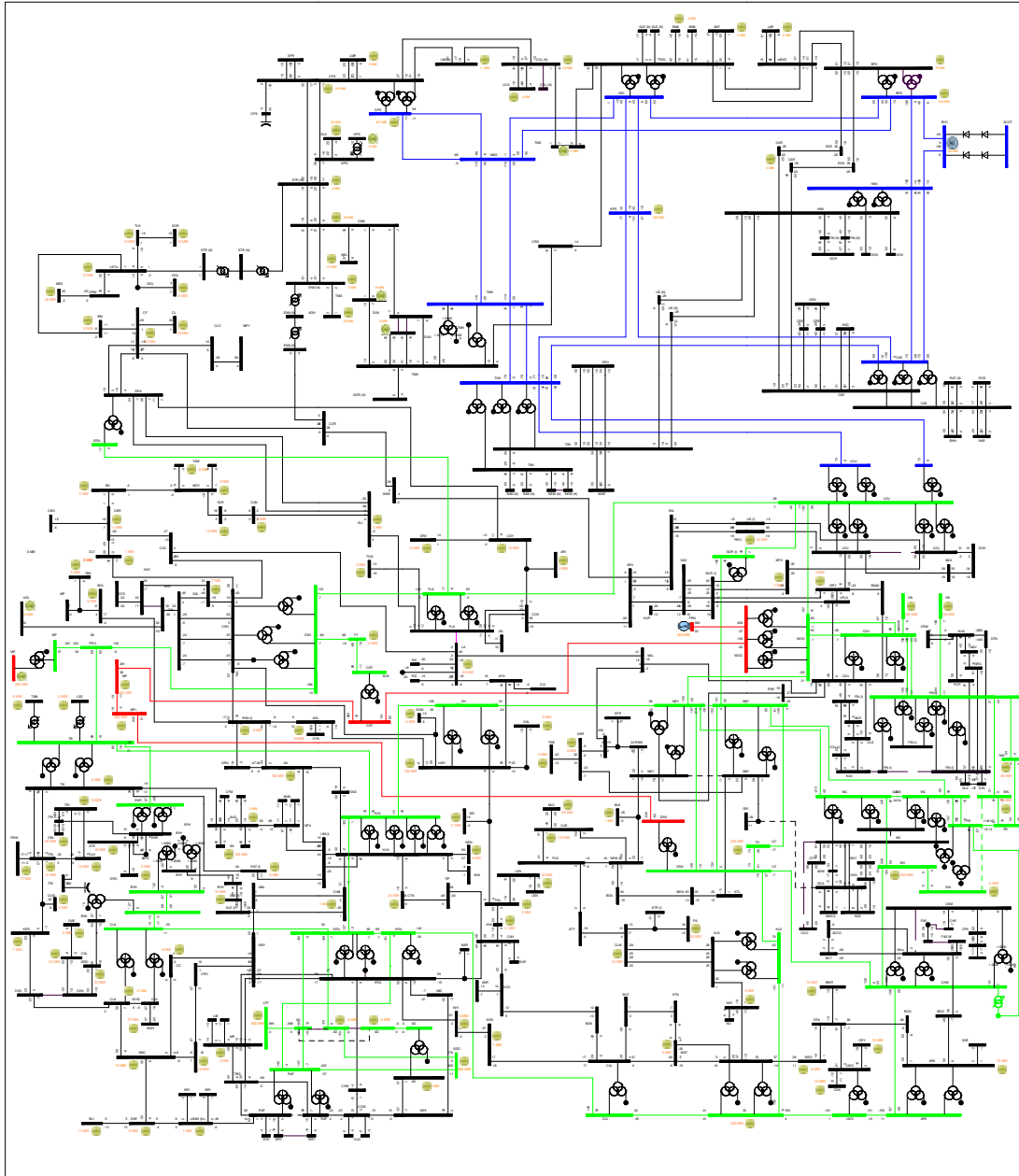
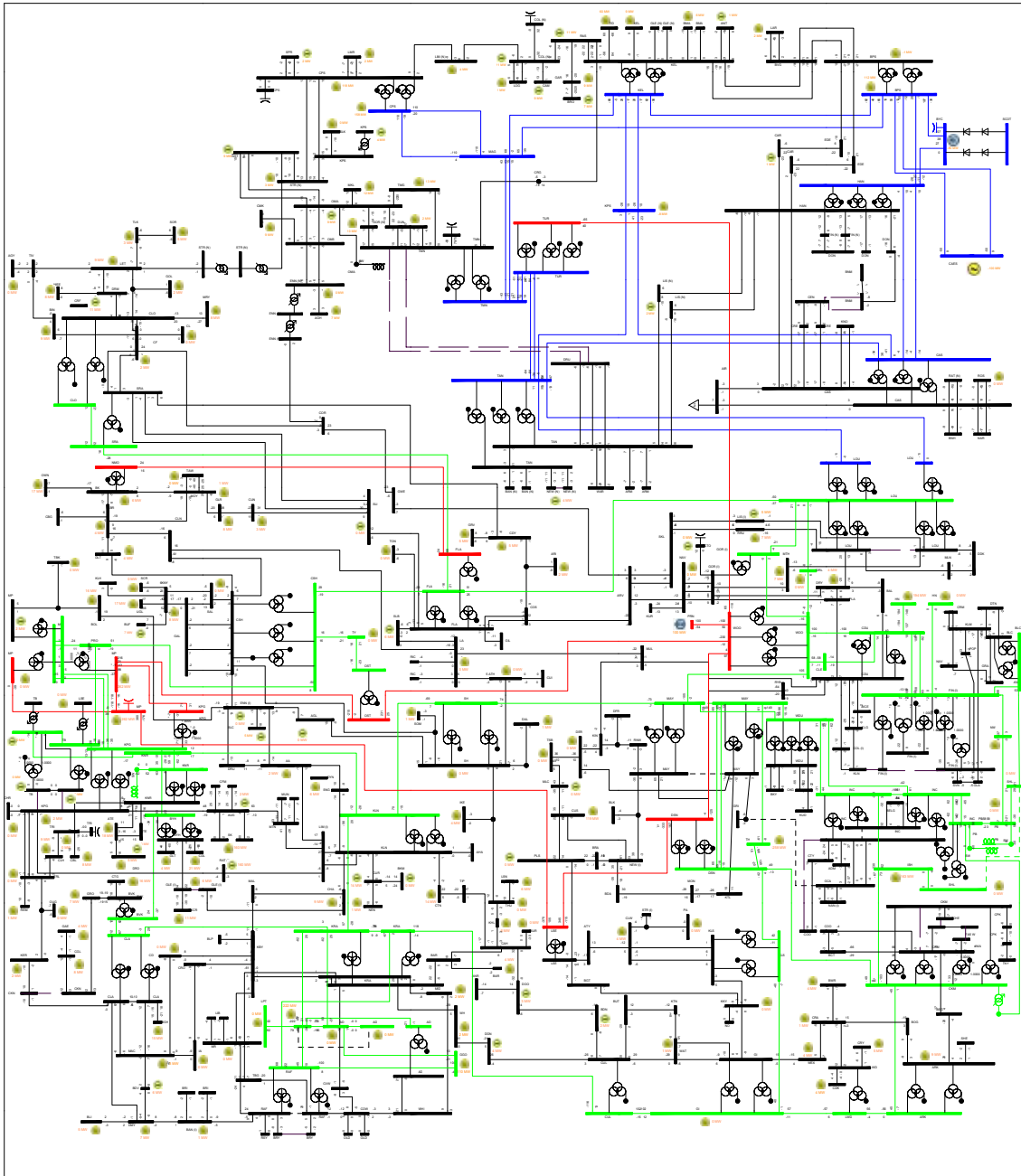

Figure H-3 Power Flow Diagram Winter Peak 2016



H-5

Figure H-4 Power Flow Diagram Summer Night Valley 2025

H-6

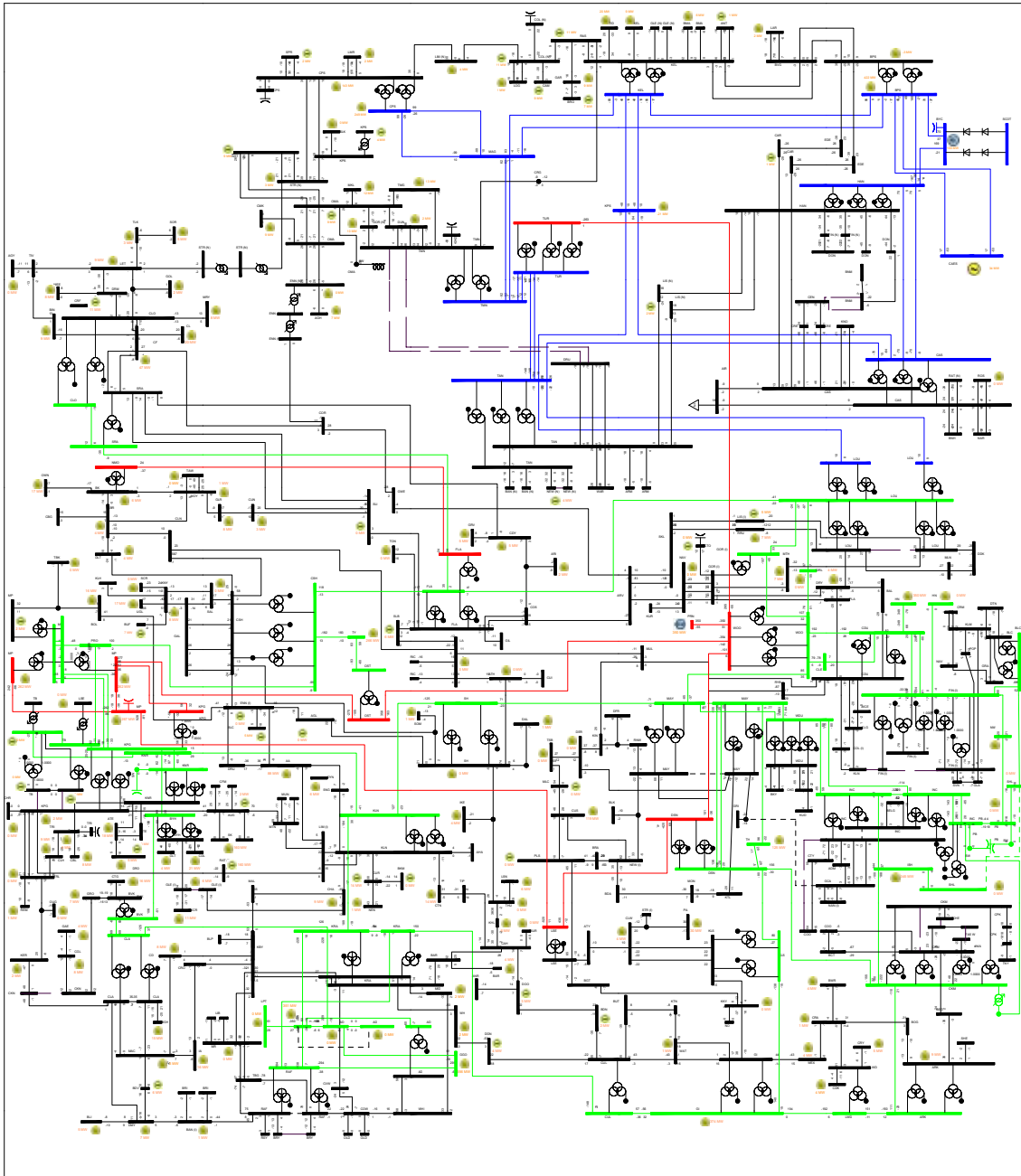

Figure H-5 Power Flow Diagram Summer Peak 2025

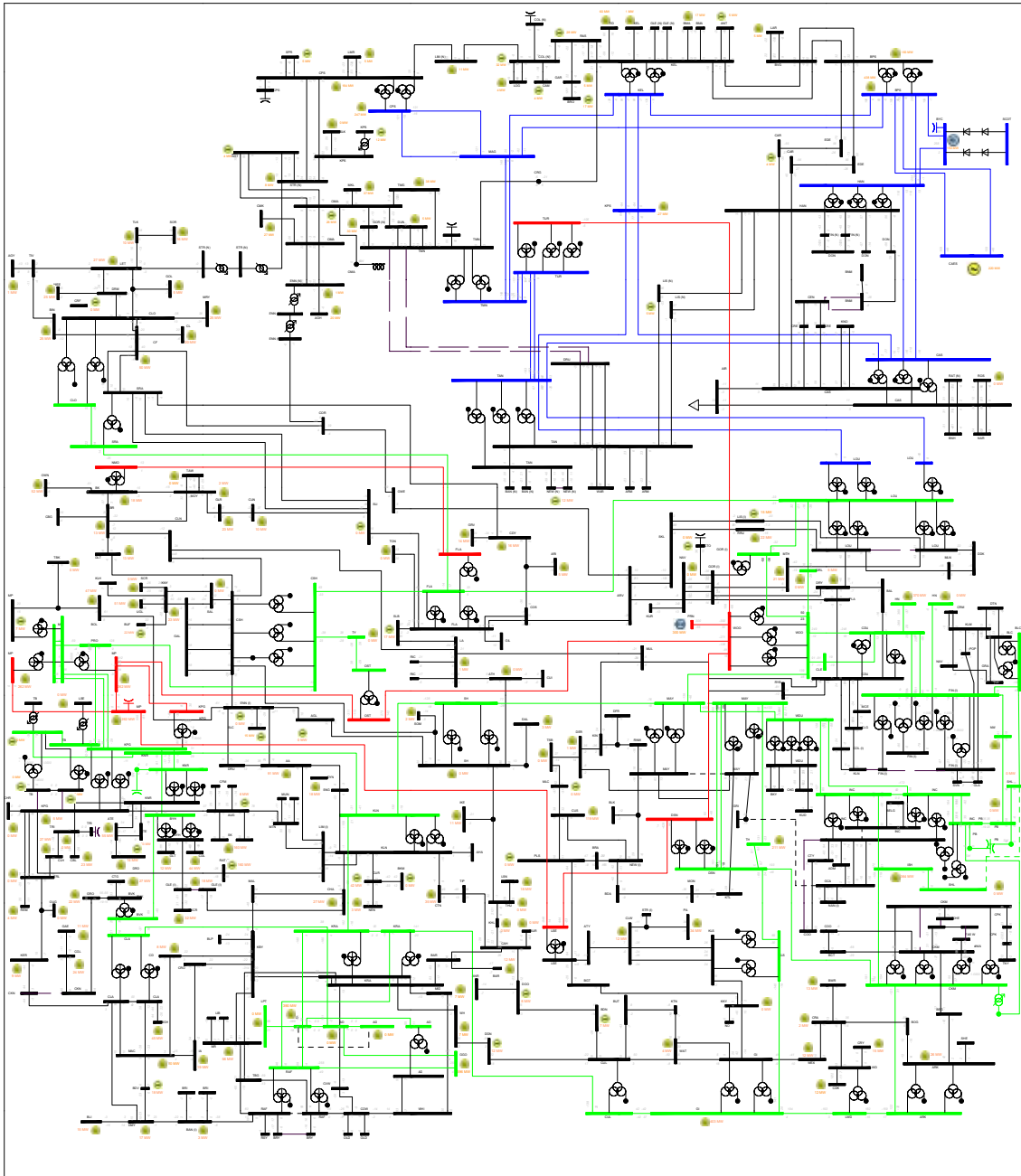

Figure H-6 Power Flow Diagram Winter Peak 2025

Notes



The Oval, 160 Shelbourne Road,
Ballsbridge, Dublin D04 FW28.
Tel: + 353 (0) 1 677 1700
www.eirgrid.com



Castlereagh House,
12 Manse Road,
Belfast, BT6 9RT.
Tel: +44 (0)28 9079 4336
www.soni.ltd.uk