

All-Island Transmission System Performance Report 2016



Table of Contents

1.	Introduction	7
2.	Executive Summary	8
3.	All-Island System Data	9
3.1	Overview of the All-Island Electricity System	9
3.2	Total System Production.....	10
3.3	System Records	10
3.4	Generation Capacity.....	11
3.5	Generation Availability	11
3.6	Generation Forced Outage Rate.....	12
3.7	Generation Scheduled Outage Rate.....	13
4.	EirGrid Transmission System Performance	15
4.1	Summary.....	15
4.2	Grid Development and Maintenance.....	15
4.2.1	Completed Capital Projects	15
4.2.2	New Connection Offers	16
4.2.3	Connections Energised.....	16
4.2.4	Customers Certified Operational.....	17
4.2.5	Maintenance Works Completed.....	18
4.3	General System Performance	19
4.3.1	Under Frequency Load Shedding	19
4.3.2	Under Voltage Load Shedding.....	20
4.4	System Minutes Lost	20
4.4.1	System Minutes Lost: EirGrid	20
4.4.2	System minutes lost: SONI.....	21
4.5	Zone Clearance Ratio.....	22
4.5.1	Zone Clearance Ratio: EirGrid.....	22
4.5.2	Zone Clearance Ratio: SONI.....	23
4.5.3	Frequency Control.....	23
4.6	Summary of key disturbances.....	24
4.6.1	Summary of key disturbances: EirGrid	24
(1)	Loss of Load	24
(2)	Under Frequency Load Shedding	24
4.6.2	Summary of key disturbances: SONI.....	25
(1)	Loss of Load	25
4.7	Transmission System Availability & Outages	26
4.7.1	Transmission System Availability	26

4.7.2	Transmission Plant Availability.....	26
4.7.3	Cause of Transmission Plant Unavailability.....	27
4.7.4	110 kV Plant Unavailability.....	28
4.7.5	220 kV Plant Unavailability.....	29
4.7.6	275 kV Plant Unavailability.....	30
4.7.7	400 kV Plant Unavailability.....	31
4.8.8.	East West Interconnector Unavailability.....	33
4.7.8	Transmission Outage Duration.....	33
4.7.9	Timing of Transmission Outages.....	34
4.7.1	Forced Outages.....	36
4.7.2	Forced Outages per km.....	36
4.7.3	Forced Outages per MVA.....	37
5.	SONI Transmission System Performance.....	38
5.1	Summary.....	38
5.2	Transmission System Availability.....	39
5.2.1	System Unavailability.....	42
5.2.2	System Historic Availability Performance.....	43
5.2.3	System Historic Unavailability Performance.....	43
5.3	Interconnector and Tie-Line Availability.....	44
5.3.1	Moyle Interconnector.....	44
5.3.2	Moyle Interconnector Historic Availability.....	45
5.3.3	Moyle Interconnector Historic Unavailability.....	45
5.3.4	Moyle Interconnector Monthly Unavailability.....	46
5.3.5	275 kV Tie Line.....	46
5.3.6	110kV Tie lines.....	47
	There are two 110 kV connections between Ireland and Northern Ireland;.....	47
5.4	Transmission System Security.....	49
5.4.1	Incidents for 2016.....	49
5.4.2	Number of Incidents and Estimated Unsupplied Energy.....	49
5.4.3	Incident Analysis.....	50
5.4.4	Unsupplied Energy.....	50
5.5	Quality of Service.....	51
5.5.1	Voltage.....	51
5.5.2	Voltage Excursions.....	51
5.5.3	Frequency.....	51
5.5.4	Frequency Excursions.....	52
5.5.5	Historical Frequency Excursions.....	53

6. Appendix 1 Glossary54

7. Appendix 2 All Island Frequency Excursion Graphs59

8. Appendix 3 All Island Fully Dispatchable Generation Plant.....70

9. Appendix 4 EirGrid Maintenance Policy Terms.....73

10. Appendix 5 Formulae (EirGrid Transmission System)75

Table of Figures

Table 1: Total Exported Energy 2015 & 2016	10
Table 2: System Records 2015 & 2016	11
Table 3: Executed Demand & Generation Connection Agreements in 2016.....	16
Table 4: Demand & Generation Connections Energised in 2016.....	17
Table 5: Customers Certified Operational in 2016.....	17
Table 6: Maintenance Summary for 2016.....	19
Table 7: Summary of UFLS disturbances in 2016: EirGrid	19
Table 8: Transmission System Plant Availability 2015 & 2016.....	27
Table 9: Transmission System Plant Unavailability Categories	27
Table 10: Transmission System Plant Outage 2016.....	32
Table 11: Voltage step change limits in operational timescales.....	51
Table 12: Frequency Excursions in 2016.....	52
Figure 1: Generation System Availability 2016	12
Figure 2: Generation System Forced Outage Rate 2016.....	13
Figure 3: Generation System Scheduled Outage Rate 2016.....	14
Figure 4: Number of STAR events 2004 - 2016.....	20
Figure 5: System minutes lost and associated targets 2003 - 2016: EirGrid	21
Figure 6: System minutes lost 2012 - 2016: SONI.....	22
Figure 7: Zone clearance ratio 2004 - 2016: EirGrid.....	22
Figure 8: Monthly Variations of System Unavailability 2015 & 2016.....	26
Figure 9: Causes of Unavailability on the 110kV System in 2016.....	29
Figure 10: Causes of Unavailability on the 220kV System in 2016	30
Figure 11: Causes of Unavailability on the 400kV System in 2016.....	31
Figure 12: Causes of East West Interconnector Unavailability in 2016.....	33
Figure 13: Duration of Outages in 2015 & 2016.....	34
Figure 14: Percentage unavailability in each month of 2015 & 2016	35
Figure 15: Average duration of outages 2015 & 2016.....	35
Figure 16: Forced Outages in 2016.....	36
Figure 17: Transformer Forced Outages in 2016.....	37
Figure 18: Transmission System Availability 2016.....	41
Figure 19: Transmission System Unavailability 2016.....	42
Figure 20: Historic System Availability 1998-2016.....	43

Figure 21: Historic System Unavailability 2005-2016..... 43

Figure 22: Historic Moyle Interconnector Availability 2002/03 - 2016..... 45

Figure 23: Historic Moyle Interconnector Unavailability 2005-2016 45

Figure 24: Moyle Interconnector Unavailability 2016 46

Figure 25: Historic North-South Tie Line Availability 1995-2016 47

Figure 26: North-South Tie Line Availability 2005-2016..... 48

Figure 27: Historic 110kV Tie Line Unavailability 2005-2016..... 48

Figure 28: Historic System Security 2005-2016..... 50

Figure 29: Historic Unsupplied Energy 2005-2016 50

Figure 30: Historic Frequency Excursions 2012-2016..... 53

Figure 31: Zones of Protection 58

1. Introduction

EirGrid and SONI, as Transmission System Operators (TSOs) for Ireland and Northern Ireland respectively, are pleased to present the annual Transmission System Performance Report for 2016. This report contains transmission system data and performance statistics for the transmission system in Ireland and Northern Ireland for the year 2016 (1st January 2016 – 31st December 2016). The report includes both transmission system performance statistics and a number of high level transmission system characteristics.

EirGrid is required to publish an annual report on the performance of the TSO business in accordance with Condition 18 of the Transmission System Operator Licence granted to EirGrid by the Commission for Energy Regulation (CER).

Similarly, SONI is required to produce an annual report on the performance of the TSO business in accordance with Condition 20 of the Licence to participate in the Transmission of Electricity granted to SONI Ltd by the Department for the Economy.

This report contains high level transmission system characteristics and a detailed breakdown of key figures along with an explanation of what these figures mean for the all-island transmission system in the coming year and into the future. Through comparison with previous reports, this report provides a useful resource through which possible trends can be identified.

This report is structured as follows:

- Section 3 outlines all-island system data, generation availability and outages,
- Section 4 details the performance of the EirGrid TSO business during 2016 against the criteria approved by the CER,
- Section 5 details the performance of the SONI TSO business during 2016 against the criteria approved by the Utility Regulator in Northern Ireland (URegNI).

Appendices which provide further detail on the data, results and methodology of relevance are included at the end of this report.

2. Executive Summary

The annual Transmission System Performance Report for 2016 is a comprehensive review of the transmission system through which EirGrid and SONI make available key all-island system operating data from the previous year.

Key statistics detailed in this report include:

- All Island Generation Statistics
- Transmission System Availability statistics for Ireland and Northern Ireland
- Details on System Events leading to System Minutes Lost
- Details of All Island System Frequency Events

KEY DATA

All-island

- All-island peak demand reached 6375 MW on Monday the 22nd November 2016. The minimum all-island demand was 2370 MW occurred on Sunday 7th August 2016.
- The all-island installed capacity of conventional, dispatchable generation in December 2016 was 9433 MW.
- In 2016 the system frequency was operated within 49.9 Hz and 50.1 Hz for 99.5% of the time
- In 2016 the system was operated at all times within acceptable international standards for safety, security and reliability of customer supplies.

Ireland

- In 2016 the availability of the East West Interconnector was 70%.
- The average plant availability in Ireland in 2016 was 95.56%.
- The System Minutes lost for 2016, attributable to EirGrid, was 0.574.

Northern Ireland

- The availability of the Moyle Interconnector for 2016 was 59.04%.
- The average availability of the Northern Ireland transmission system was in 2016 was 96.64%.
- The System Minutes lost for 2016, in Northern Ireland was 1.705.

3. All-Island System Data

3.1 Overview of the All-Island Electricity System

The transmission system in Ireland and Northern Ireland provides the means to transport energy from generators to demand centres across the island. The transmission system is comprised of high voltage overhead lines and cables that connect power stations, interconnectors and substations. Transformers link different voltage levels and provide a path for power to flow from higher to lower voltage networks. The transmission system in Ireland is operated at 400 kV, 220 kV and 110 kV. The transmission system in Northern Ireland is operated at 275 kV and 110 kV.

The 400 kV, 275 kV and 220 kV networks form the backbone of the transmission system. They have higher power carrying capacity and lower losses than the 110 kV network.

The Ireland and Northern Ireland transmission systems are electrically connected by means of one 275 kV double circuit. This connection is from Louth station in Co. Louth (IE) to Tandragee station in Co. Armagh (NI).

There are also two 110 kV connections:

- Letterkenny station in Co. Donegal (IE) to Strabane station in Co. Tyrone (NI)
- Corraclassy station in Co. Cavan (IE) to Enniskillen station in Co. Fermanagh (NI)

This section contains basic all-island transmission system data. Further information can be found on the EirGrid Group website: www.eirgridgroup.com.

3.2 Total System Production

The total exported energy takes into account energy supplied by large and small-scale generation as well as pumped storage units on the island.

Table 1: Total Exported Energy 2015 & 2016

	2015	2016
All-Island Total Exported Energy [GWh]	35,735	36,345
Ireland Total Exported Energy [GWh]	26,959	27,585
Northern Ireland Total Exported Energy [GWh]	8,776	8,759

3.3 System Records

Peak demand is a measure of the maximum demand on the transmission system over a particular period (e.g. annual or seasonal) and is a key measurement for any power system. The transmission system in Ireland and Northern Ireland is a winter peaking system as a result of greater heating and lighting requirements during the winter months. The all-island winter peak in 2016 was 6375 MW and occurred at 17:15 on Monday 22nd of November.

In summer, the reduced need for heating and lighting results in a lower demand for electricity. The minimum demand is known as the ‘minimum summer night valley’ and in 2016 a minimum all-island demand of 2370 MW was recorded at 06:00 on Sunday 7th August.

The installed wind capacity continues to increase year-on-year, enabling Ireland and Northern Ireland to progress towards the target of having 40% of our electricity produced by renewable sources by 2020. From the installed wind capacity a peak all-island wind generation output of 2812 MW was achieved. Table 2 provides a summary of the system records for 2015 and 2016.

Table 2: System Records 2015 & 2016

	2015	2016
Winter Peak Demand [MW]	6392	6,375
Minimum Summer Night Valley [MW]	2295	2370
Maximum Wind Generation [MW]	2607	2812

3.4 Generation Capacity

Generating plant is connected to both the transmission and distribution systems. All generation contributes to meeting system demand. The total generation capacity is calculated as the sum of all fully operational generator capacities connected to both systems¹.

The all-Island installed capacity of conventional, dispatchable generation in December 2016 was 9433 MW (7,225 MW in Ireland and 2208 MW in Northern Ireland). This does not include any import capacity from the Moyle Interconnector or the East West Interconnector.

The all-island installed capacity of wind generation in December 2016 was 3,014 MW (2,215 MW in Ireland and 799 MW in Northern Ireland).

Appendix 3 provides a list of the fully dispatchable generating units connected to the transmission system.

3.5 Generation Availability

Generation Availability is a measure of the capability of a generator to deliver power in a given period to the transmission system. In order for EirGrid and SONI to operate a secure and reliable transmission system in an economic and efficient manner, it is necessary for generators to maintain a high rate of availability.

Generation system availability is calculated on a daily and 365-day rolling average basis². Figure 1 shows the daily and 365-day rolling average availability for 2016.

¹ Fully operational generator capacity is given by the Maximum Export Capacity (MEC) of the generator

² 365-day rolling average is a capacity weighted average availability over the previous 365 days

Figure 1: Generation System Availability 2016

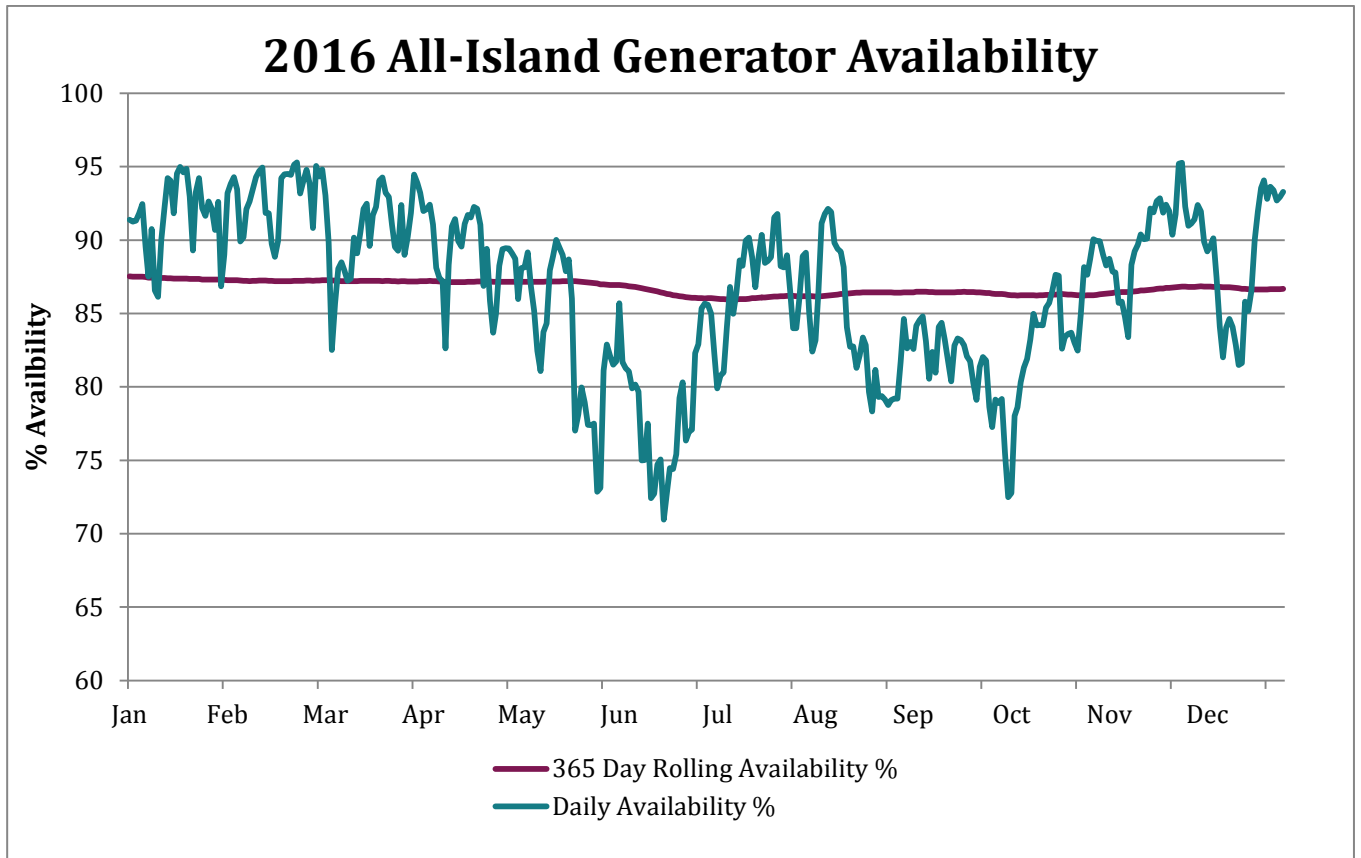

- The average daily generation system availability in 2016 was 86.77%
- The maximum daily generation system availability in 2016 was 95.30%.
- The minimum daily generation system availability in 2016 was 70.96%.

3.6 Generation Forced Outage Rate

The generation forced outage rate (FOR) is calculated on a daily and rolling 365-day average basis. The daily FOR is a capacity weighted percentage of the time during the day that generation units are unavailable due to unforeseen/unplanned outages. The 365-day rolling FOR is the average of the daily FOR over the previous 365 days. The daily FOR and 365-day rolling FOR are shown in Figure 2.

Figure 2: Generation System Forced Outage Rate 2016

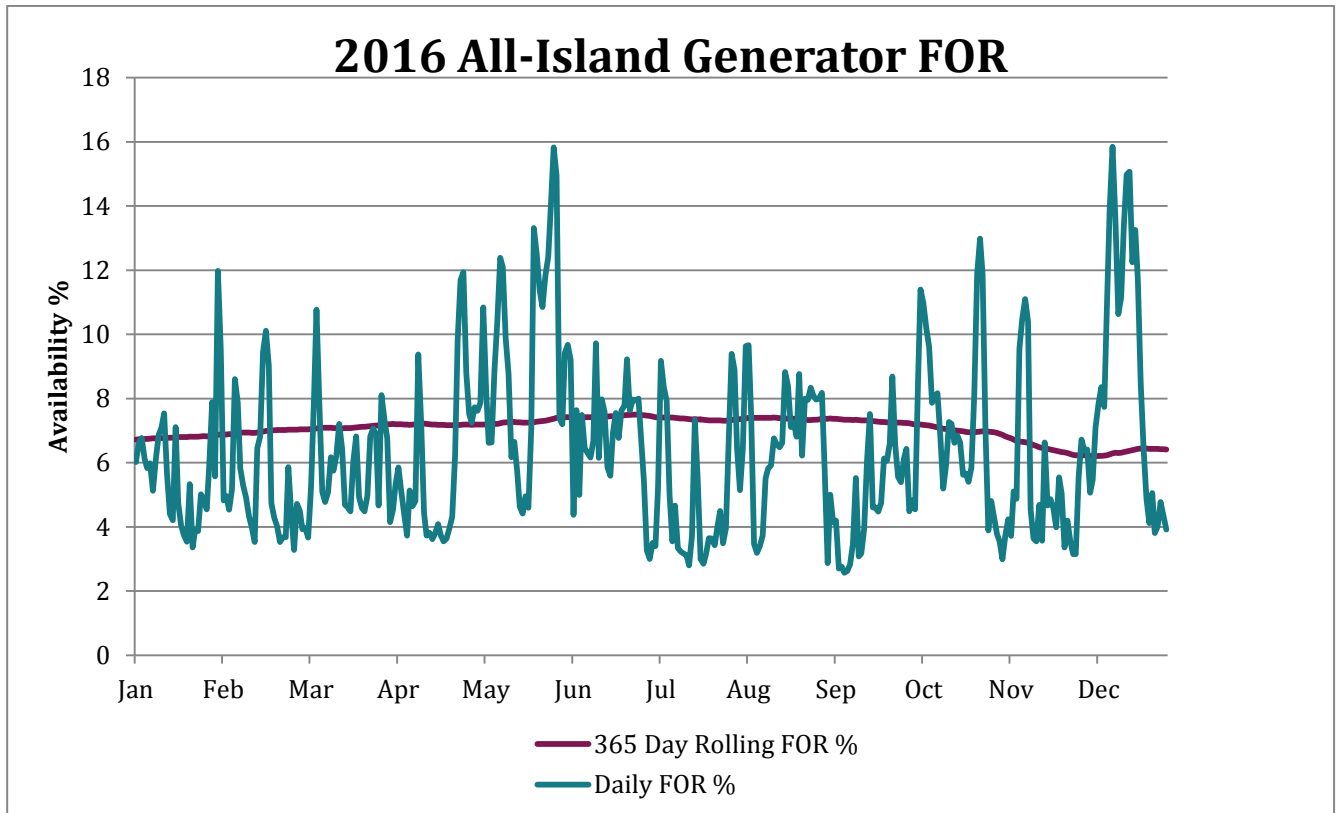

- The average daily generation system forced outage rate in 2016 was 6.4%.
- The highest forced outage rate in 2016 was 15.85%.
- The minimum daily generation system forced outage rate in 2016 was 2.57%.

3.7 Generation Scheduled Outage Rate

The generation scheduled outage rate (SOR) can be calculated on a daily and rolling 365-day average basis. The daily SOR is a capacity weighted percentage of the time during the day that generation units are unavailable due to planned outages. The 365-day rolling SOR is the average of the weekly SOR over the previous 365 days.

The daily SOR and 365-day rolling SOR are shown in Figure 3.

Figure 3: Generation System Scheduled Outage Rate 2016

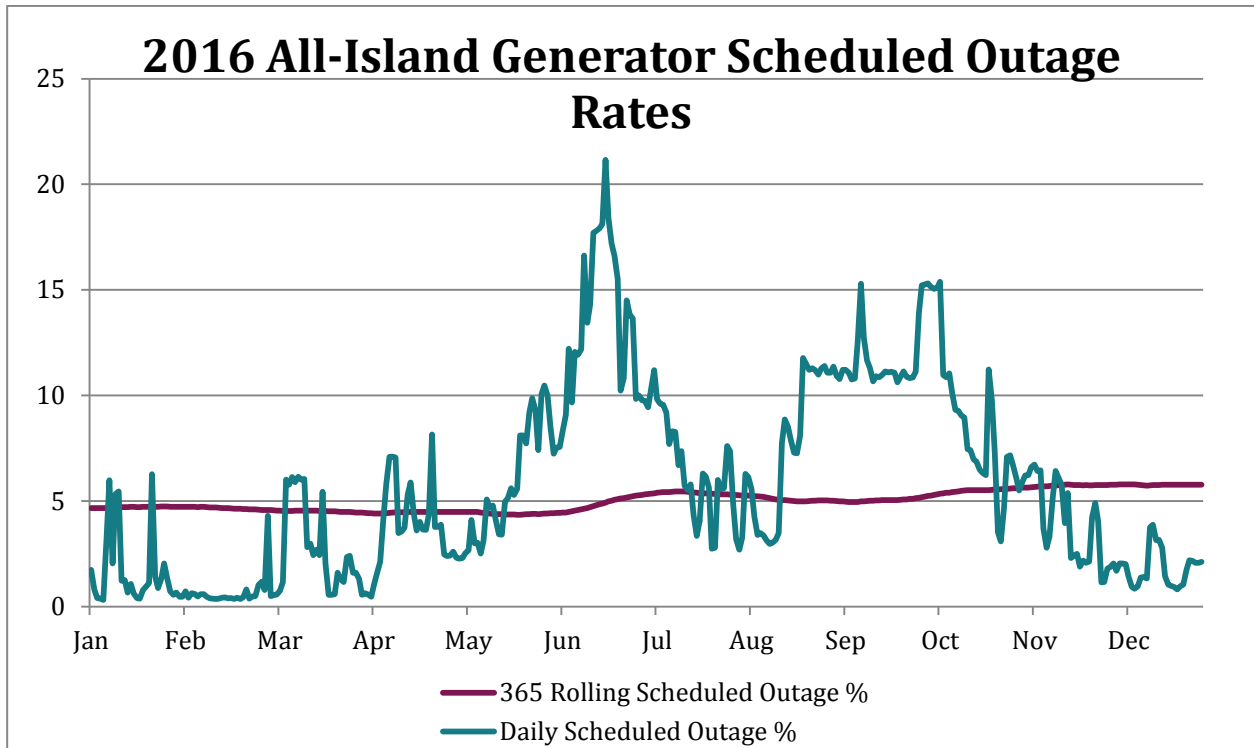

- The average daily generation system scheduled outage rate in 2016 was 5.69%.
- The maximum daily generation system scheduled outage rate in 2016 was 21.16%.
- The minimum daily generation system scheduled outage rate in 2016 was 0.31%.

4. EirGrid Transmission System Performance

This section relates to the performance of EirGrid TSO and the transmission system in Ireland only, unless explicitly stated otherwise. This data has been prepared by EirGrid in accordance with the requirements of Part 5 of Condition 18 of its Transmission System Operator Licence.

4.1 Summary

The system was operated at all times within acceptable international standards for safety, security and reliability of customer supplies. All security of supply Key Performance Indicators (KPIs) were achieved throughout the year.

The System Minutes lost as a result of faults on the Main System was 0.574 in 2016. No System Minutes were lost due to the disconnection of Normal Tariff load customers during UFLS disturbances.

EirGrid have a target to operate the system frequency within the range 49.9 Hz to 50.1 Hz for 94% of the time. In 2016, the system frequency was within the agreed limits 99.5% of the time.

4.2 Grid Development and Maintenance

This section provides an overview of grid development activities in 2016.

4.2.1 Completed Capital Projects

The following capital projects were completed in 2016:

- Ballynahulla 220/110 kV Station
- Ballyvouskil 220kV Station
- Knockanure 220/110 kV Station
- Clogher 110 kV station and associated works
- HV Line Tower Painting - South
- Cashla 110 kV Station - replace two CBs
- Cloghran - Corduff 110 kV Cable Reinforcement

- Galway 110 kV Station - replace two CBs
- Arva - Shankill No 1 110kV line uprate
- Louth Refurbishment Enabling Works
- Great Island 220kV Station Refurbishment/Replacement
- Sliabh Bawn 110 kV station [IPP]
- Carrickmines 220kV Station - 3rd 250MVA 220/110kV Transformer
- Carrick-on-Shannon 110kV Station BB uprate

4.2.2 New Connection Offers

Parties seeking a new connection to the transmission system or to amend an existing Connection Agreement must apply to EirGrid for a connection offer. EirGrid operates a standard regulatory approved process for providing Connection Offers to generators and demand customers seeking direct connection to the transmission system.

In order to connect to the transmission system, all demand and generation customers must execute a Connection Agreement with EirGrid. Table 3 summarises the total number of executed Connection Agreements in 2016 and their associated load or generation capacities. A connection offer which is accepted in one year is unlikely to impact on connected generation capacity in the same year given the lead times associated with construction.

Table 3: Executed Demand & Generation Connection Agreements in 2016

	Demand	Generation
Executed Connection Offer Agreements in 2016 [No.]	5	1
Executed Connection Offer Agreements in 2016 [Capacity]	293.67MVA	41.6MW

As well as the connection offers issued and accepted there has been a significant increase in the work done to modify connection agreements in 2016.

4.2.3 Connections Energised

When a Connection Agreement is executed for a new connection, it typically takes a number of years before the demand or generation is connected to the transmission system. This period includes project development, time taken to obtain consents and to construct the connection.

When the transmission connection is energised, it then takes a number of months for the generator to reach commercial operation. This period is generally much shorter for demand customers.

Table 4 provides an overview of the number of new connections to the transmission system commissioned in 2016.

Table 4: Demand & Generation Connections Energised in 2016

	Demand	Generation
Connections Energised in 2016 [No.]	0	3
Connections Energised in 2016 [Capacity]	0 MVA	154 MW

4.2.4 Customers Certified Operational

Table 5 provides an overview of customers connected to the transmission system who have been deemed fully operational. It shows customer connections which have completed the testing phase and have received an operational certificate from EirGrid. This includes generators connected to the distribution network. Note that demand customers are not currently certified by EirGrid and are therefore not included in the table.

Table 5: Customers Certified Operational in 2016

Without Fuel Unit and EWIC:

	Total No. of sites Certified Operational 2016
Customers Certified Operational [Total No. of sites]	23
Customers Certified Operational [MW Capacity]	727.152

With Fuel Units and EWIC:

	Total No. of sites Certified Operational 2016
Customers Certified Operational [Total No. of sites]	28
Customers Certified Operational [MW Capacity]	2594.152

As of the end of 2016, there were a total of 15 Demand Side Units (DSU) certified as operational with a total capacity of 334 MW.

4.2.5 Maintenance Works Completed

Transmission maintenance is undertaken in accordance with EirGrid's maintenance policy to ensure that the transmission system can operate in a safe, secure and reliable manner. The policy comprises continuous and cyclical condition monitoring (on-line and off-line), preventative maintenance of plant and the implementation of corrective maintenance tasks. The maintenance policy is kept under review to ensure that it continues to meet the requirements of the system and best international practice. On an annual basis, transmission maintenance activities dictated by the asset maintenance policy and protection maintenance policy, along with work identified from analysis of plant condition and work carried over from the previous year combine to form the planned maintenance requirements for the year. This is then included in the Transmission Outage Plan.

During the relevant year, due to a variety of reasons (including resource limitations, outage restrictions, material availability, system conditions, CAPEX projects etc.), it may be necessary to defer programmed maintenance activities. The TSO will consider the appropriateness or otherwise of deferring preventive and/or corrective maintenance activities. This is subject to prioritisation and deferral assessments in accordance with established EirGrid procedures. These assessments will consider system/safety/environmental impact, duration of outage, controls and mitigation measures. Deferrals are kept under review, as any increase in backlog could have a negative impact on the reliability and performance of the transmission system.

Table 6 provides, in volume terms, a summary of transmission maintenance requirements, maintenance programmed and maintenance completed in 2016 for overhead lines, underground cables and transmission stations. In order to facilitate more maintenance work and CAPEX projects, EirGrid took the decision in 2015 to extend the transmission outage season by two months; work now takes place from the beginning of March and continues until the end of November.

Table 6: Maintenance Summary for 2016

Volume of Transmission Maintenance by Activity	Maintenance Programme Year End	Maintenance Completed
Overhead Line Maintenance		
Patrols (incl. Helicopter, climbing, infrared & Bolt) [km]	8,634	7,546
Timber Cutting [km]	74	63
Structure & Hardware Replacement [Number]	168	96
Insulator & Hardware Replacement [Number]	36	26
Underground Cable Maintenance		
Alarm Checks / Inspection [Number]	596	490
Station Maintenance		
Ordinary Service [Number]	297	232
Operational Tests [Number]	752	557
Condition Assessment of Switchgear [Number]	165	107
Tap Changer Inspection [Number]	8	7
Corrective Maintenance Tasks [No. of Tasks]	423	263

4.3 General System Performance

4.3.1 Under Frequency Load Shedding

There were no under frequency load shedding disturbances (UFLS) in 2016 which resulted in shedding of normal tariff load customers. Short term active response (STAR) interruptible load customers were disconnected on three occasions. All three UFLS disturbances were due to large generator trips in the South East.

Table 7 provides a summary of each UFLS event. The relays to disconnect normal tariff customer load are only activated once the system frequency drops to 48.85 Hz. The time to recover to 49.9 Hz starts from 49.3 Hz, the point at which the STAR under frequency relays are activated. The lowest system frequency in 2016 was 49.23 Hz; during the second and third UFLS disturbances.

Table 7: Summary of UFLS disturbances in 2016: EirGrid

SDR No.	Date	Unit	MW	Freq, Hz	49.9 Hz, minutes	MVA Minutes	STAR SM	NT SM
T20/2016	09/04/16	Gen	441	49.27	0.196	81.11	0.013829	0
T29/2016	20/05/16	Gen	432	49.23	1.496	140.91	0.024024	0
T32/2016	31/05/16	Gen	411	49.23	0.154	77.47	0.013207	0

The upper limit for activation of STAR schemes is 16 events per year. The number of STAR events each year since 2004 is presented in Figure 4. The mean over this period was 2.8 events per year. System minutes lost due to activation of the STAR scheme are not attributable to EirGrid due to STAR being a pre-existing contractual arrangement with the customers.

Figure 4: Number of STAR events 2004 - 2016

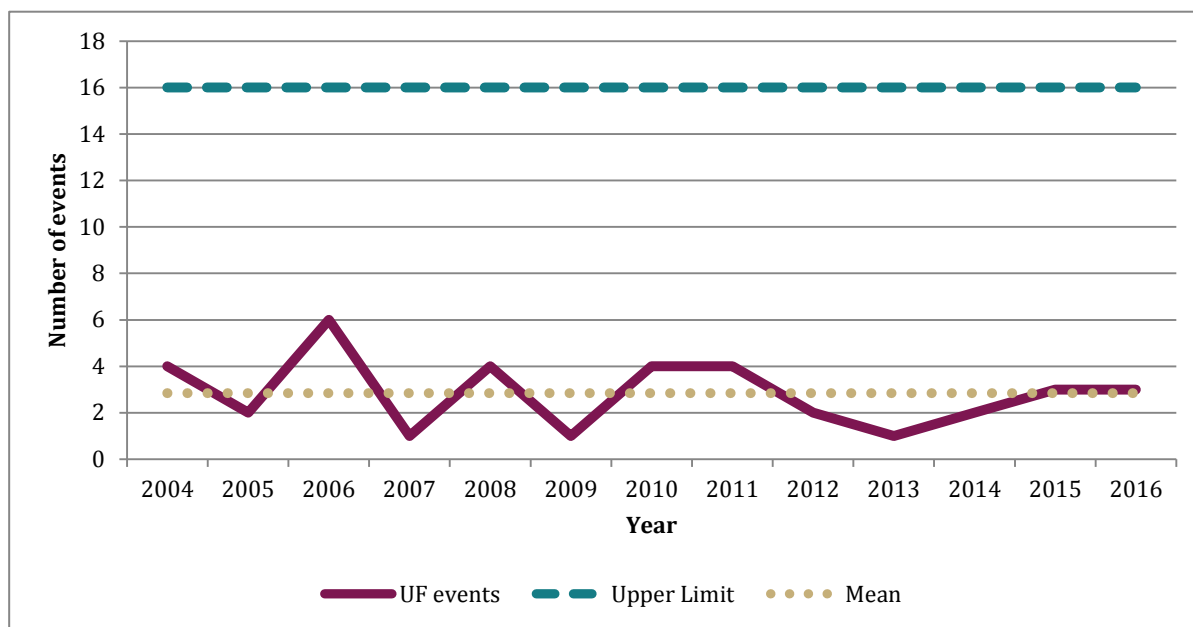

4.3.2 Under Voltage Load Shedding

There was no incident of Under Voltage Load Shedding in 2016.

4.4 System Minutes Lost

4.4.1 System Minutes Lost: EirGrid

The total system minutes lost (SML) for 2016, attributable to EirGrid, was 0.574.

The system minutes lost as a result of faults on the main system was 0.574 in 2016. No system minutes were lost due to the disconnection of normal tariff load customers during UFLS disturbances.

The trend of system minutes lost since 2003 is shown in Figure 5, with incentive target areas and deadband, as provided by the Commission for Energy Regulation. The average number of system minutes lost since 2003, attributable to EirGrid, was 1.17 with a standard deviation of 1.25.

The central target provided up to 2010³ was replaced with a deadband in 2011⁴. The deadband is between 1.5 SML and 3.0 SML, where there is neither penalty nor incentive. EirGrid is awarded one fifth of the incentive amount for every 0.1 SML below 1.5 SML, down to 1.0 SML. EirGrid is penalised one fifth of the incentive amount for every 0.1 SML above 3.0 SML, up to a maximum penalty at 3.5 SML.

Figure 5: System minutes lost and associated targets 2003 - 2016: EirGrid

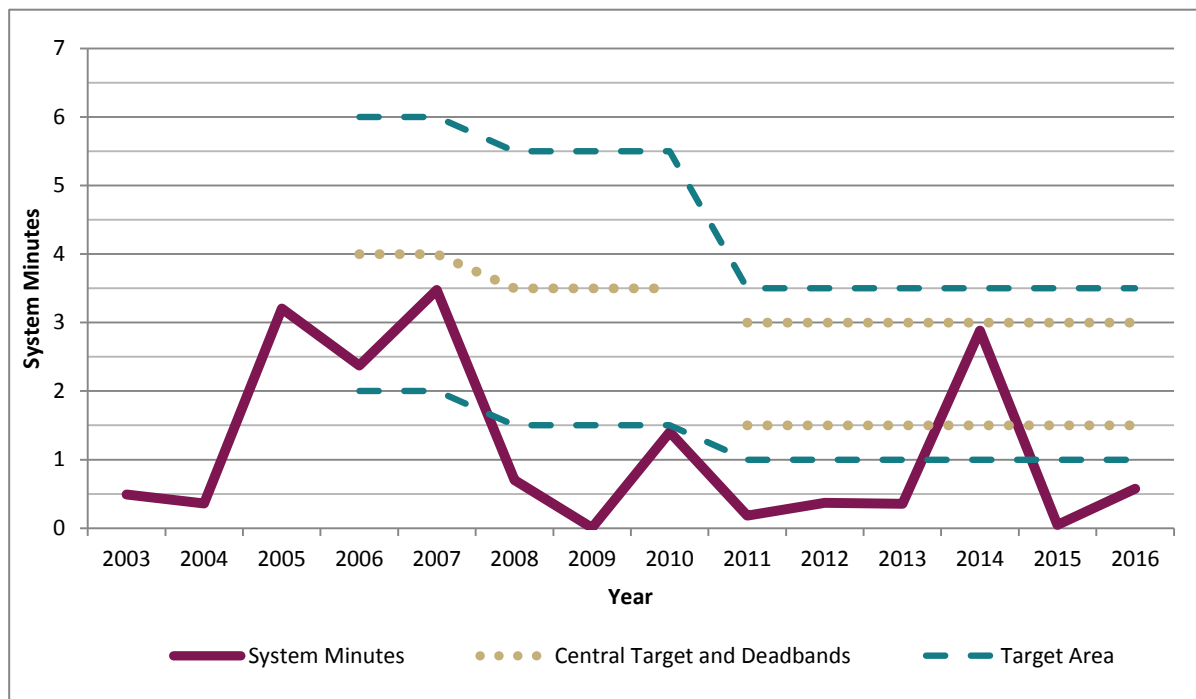

4.4.2 System minutes lost: SONI

The total system minutes lost for 2016, attributable to SONI, was 1.705.

The system minutes lost as a result of faults on the main system was 1.705 in 2016. No system minutes were lost due to the disconnection of normal tariff load customers during UFLS disturbances.

The trend of system minutes lost since 2012 is shown in Figure 6.

³ CER09004: TSO System Performance Incentives (SPIs) for 2009 & 2010

⁴ CER11128: Decision on 2011/2012 Transmission Incentives

Figure 6: System minutes lost 2012 - 2016: SONI

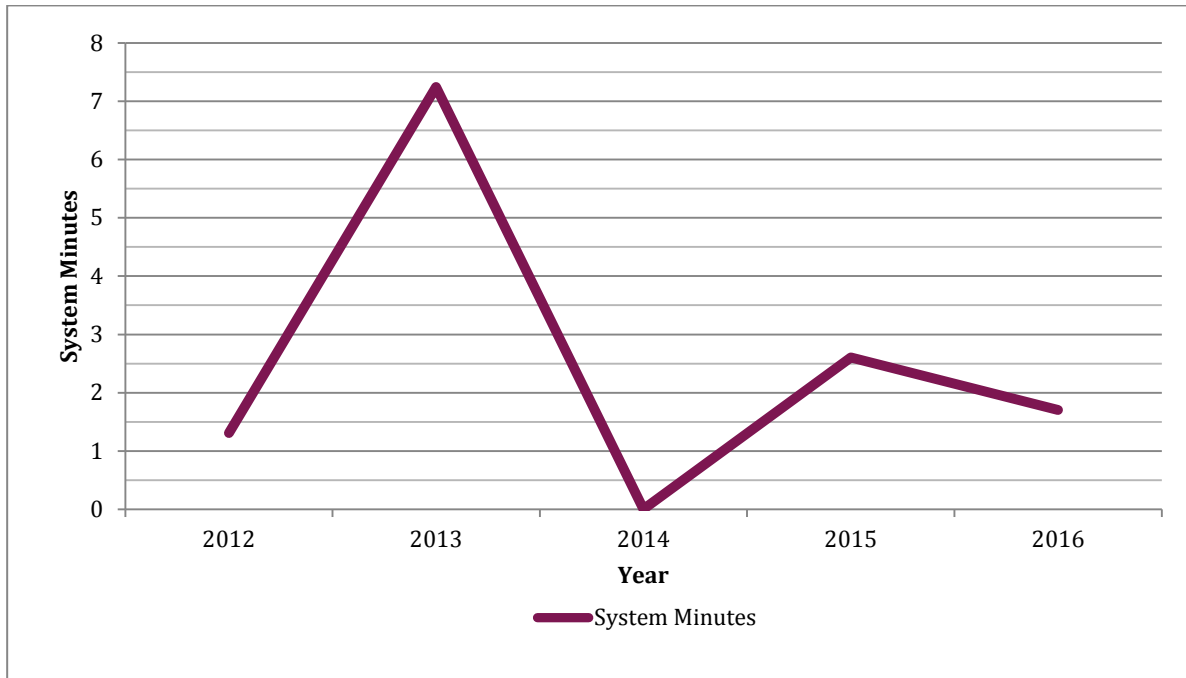

4.5 Zone Clearance Ratio

The Zone Clearance Ratio (ZCR) is defined as the ratio of the number of short circuit, system faults, not cleared in Zone 1 to the total number of short circuit faults per year cleared by Main System protection. See Appendix A for further definition of Zones and ZCR.

4.5.1 Zone Clearance Ratio: EirGrid

In 2016, the ZCR was 0.056. The ZCR trend since 2004 is shown in Figure 7.

Figure 7: Zone clearance ratio 2004 - 2016: EirGrid

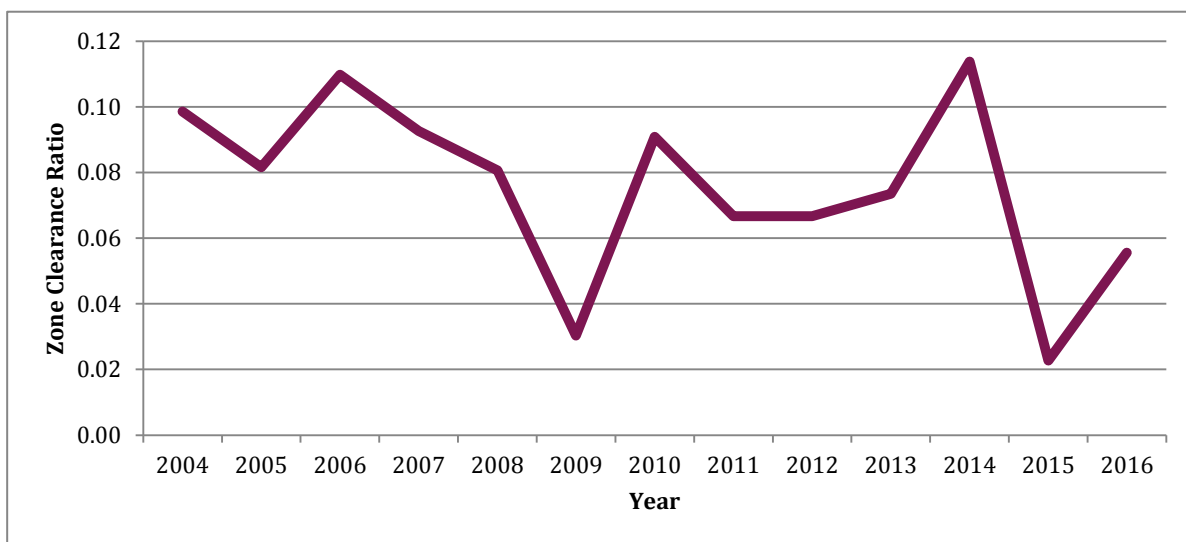

There were 36 system faults cleared by protection on the main system. Figure 7 is made up of 35 faults on the main system and one fault outside the main system.

Of the 36 system faults cleared by main system protection, 34 were cleared in zone 1, one in zone 2, and one outside zone 1 and zone 2.

A three phase fault on the Avra - Navan 110 kV line was cleared in zone 2 from the Arva end. This was due to the failure of power line carrier (PLC) teleprotection signals to reach the remote end relays to allow accelerated tripping. The fault clearance time was approximately 459 ms.

A phase to phase fault (ST) occurred between the Knockearagh/Oughtragh 110 kV busbar disconnects in Tralee 110 kV station, after they were inadvertently opened while the circuit was on load. There is no busbar protection in Tralee thus the fault was cleared by overcurrent protection on the sectionalising circuit breaker in Tralee, impedance protection in Tarbert on the Tralee 2 110 kV cubicle, and T141 38 kV protection in Tralee. The fault clearance time was 1934 ms.

4.5.2 Zone Clearance Ratio: SONI

In 2016, the ZCR was 0.083. There were 12 system faults cleared by protection on the main system; all faults occurred on the main system. Of the 12 faults, 11 were cleared in zone 1, and one outside zone 1 and zone 2.

A three phase fault occurred on the 30 MVAR reactor connected to 22 kV tertiary winding of IBTX2 in Hannahstown. The fault clearance time was 4858 ms.

4.5.3 Frequency Control

In 2016 the system frequency was operated between 49.9 Hz to 50.1 Hz for 99.5% of the time.

This figure of 99.5% exceeds the 2016 target of 94%.

4.6 Summary of key disturbances

4.6.1 Summary of key disturbances: EirGrid

(1) Loss of Load

T33/2016: Dunfirth, Kinnegad, Thornsberry

At 13:02 hours on Monday 06 June 2016, the Dunfirth - Kinnegad - Rinawade 110 kV line tripped and reclosed for a three phase fault. The fault was caused by lightning. Supply was lost to Kinnegad, Dunfirth, Derryiron and Thornsberry 110 kV stations which were tail fed from Maynooth 220 kV station due to an outage of the Derryiron - Maynooth 110 kV line. 33 MW of load was disconnected at Dunfirth, Kinnegad and Thornsberry for the fault deadtime of approximately 765 ms. 0.000079 system minutes were lost due to the fault.

T33/2016: Dunfirth, Thornsberry

At 13:08 hours on Monday 06 June 2016, the Dunfirth/Kinnegad 110 kV CB in Rinawade tripped and reclosed for a three phase fault on the line. The fault was caused by lightning. 22.8 MW of load was disconnected at Dunfirth and Thornsberry for the fault deadtime of approximately 750 ms. 0.000054 system minutes were lost due to the fault.

T46/2016: Knockearagh, Oughtragh, Tralee

At 09:09 hours on Friday 22 July 2016, the Knockearagh/Oughtragh 110 kV busbar disconnect in Tralee 110 kV station was inadvertently opened while the circuit was on load. A phase to phase fault (ST) occurred between the busbar disconnects, which evolved into a three phase fault. There is no busbar protection in Tralee thus the fault was cleared by overcurrent protection on the sectionalising circuit breaker in Tralee, impedance protection in Tarbert on the Tralee 2 110 kV cubicle, and T141 38 kV protection in Tralee. 73.2 MW of load fed from Tralee, Knockearagh and Oughtragh was disconnected for between 26 and 62 minutes. 0.574222 system minutes were lost due to the fault

(2) Under Frequency Load Shedding

T20/2016: CCGT trip

At 23:27 hours on Saturday 09 April 2016, a CCGT tripped from 441 MW. System frequency dropped from 49.99 Hz to 49.27 Hz at nadir. Frequency recovered to 49.9 Hz within 12 seconds. The STAR scheme was activated during this incident, which resulted in the disconnection of 39.2 MW of transmission connected interruptible industrial customer

load for 1 minute 52 seconds. 0.013829 STAR system minutes were lost. The system minutes lost during this incident relate entirely to STAR customers.

T29/2016: CCGT trip

At 21:51 hours on Friday 20 May 2016, a CCGT tripped from 432 MW. System frequency dropped from 50.02 Hz to 49.23 Hz at nadir. Frequency recovered to 49.9 Hz within 1 minute 30 seconds. The STAR scheme was activated during this incident, which resulted in the disconnection of 40.1 MW of transmission connected interruptible industrial customer load for 3 minutes 10 seconds. 0.024024 STAR system minutes were lost. The system minutes lost during this incident relate entirely to STAR customers.

T32/2016: CCGT trip

At 14:59 hours on Tuesday 31 May 2016, a CCGT tripped from 411 MW. System frequency dropped from 49.96 Hz to 49.23 Hz at nadir. Frequency recovered to 49.9 Hz within 10 seconds. The STAR scheme was activated during this incident, which resulted in the disconnection of 38.3 MW of transmission connected interruptible industrial customer load for 1 minute 49 seconds. 0.013207 STAR system minutes were lost. The system minutes lost during this incident relate entirely to STAR customers.

4.6.2 Summary of key disturbances: SONI

(1) Loss of Load

T34/2016: Lisburn

At 00:52 hours on Tuesday 07 June 2016, the Lisburn - Tandragee A 110 kV line tripped for a phase to phase fault (RT). The fault was caused by lightning. 25 MW of load fed from Lisburn was disconnected for nine minutes. 0.133650 system minutes were lost due to the fault.

T34/2016: Lisburn

At 01:30 hours on Tuesday 07 June 2016, the Lisburn - Tandragee A 110 kV line tripped for a single phase to ground fault (RE). The fault was caused by lightning. 20 MW of load fed from Lisburn was disconnected for two minutes. 0.023760 system minutes were lost due to the fault.

T44/2016: Antrim, Ballymena, Glengormley

At 21:40 hours on Wednesday 20 July 2016, sections 2L and 2R of the 110 kV busbar in Kells 275 kV station were stripped by operation of 110 kV busbar protection to clear a single phase to ground fault (TE). The fault was due to inadvertent action by an operator

in the station who was carrying out switching at the time of the incident. 77 MW of load at Glengormley, Antrim and Ballymena was disconnected for between 31 and 34 minutes. 1.547961 system minutes were lost due to the fault.

4.7 Transmission System Availability & Outages

4.7.1 Transmission System Availability

When considering transmission system availability, it is the convention to analyse it in terms of transmission system unavailability. The formula for calculating transmission system unavailability is given in Appendix 1. Figure 8 shows the percentage Transmission System Unavailability in each month for 2015 and 2016.

Figure 8: Monthly Variations of System Unavailability 2015 & 2016

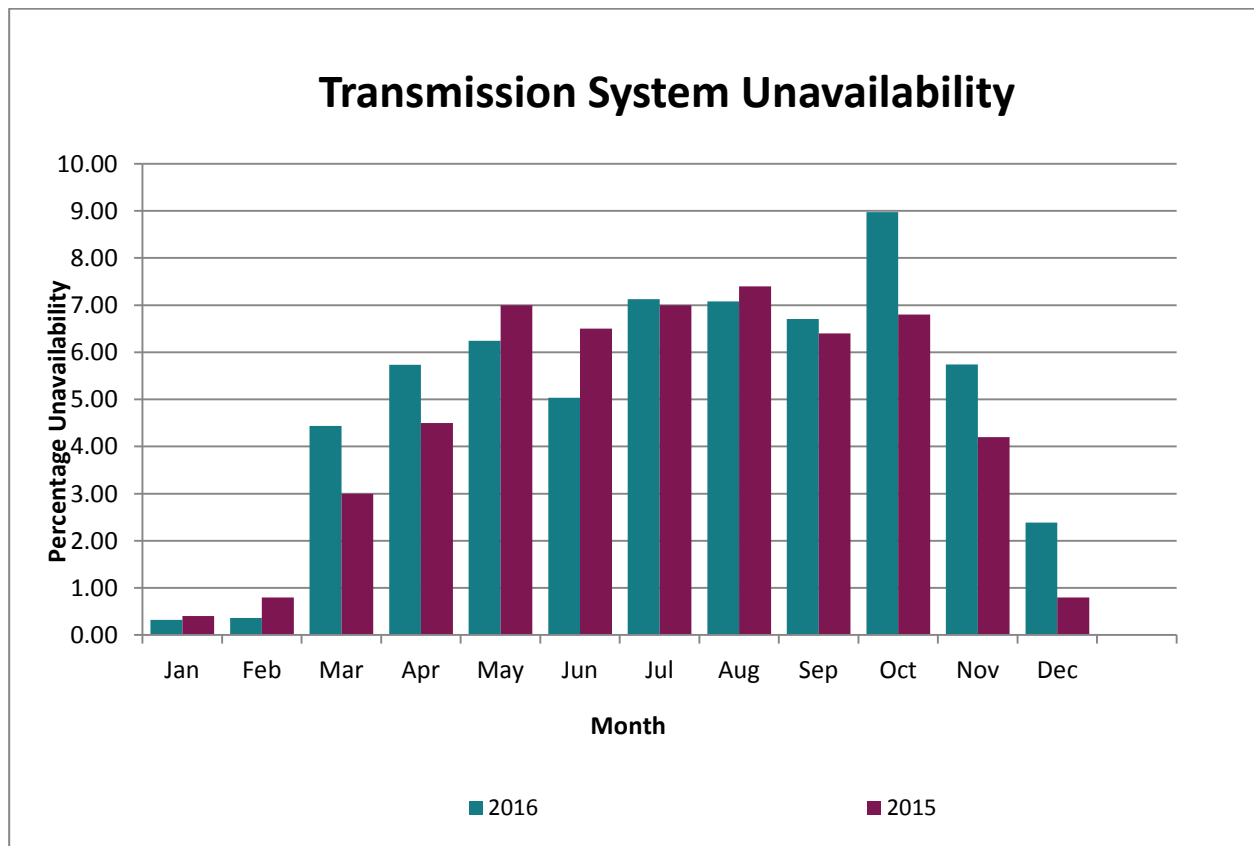

4.7.2 Transmission Plant Availability

The measure of plant availability is the kilometre-day for feeders and the MVA-day for transformers. The availability figures vary between the different categories of plant. The formulae for calculating transmission plant availability are provided in Appendix 1.

Table 8 provides a detailed breakdown of all plant availability figures for 2015 and 2016.

Table 8: Transmission System Plant Availability 2015 & 2016

Plant Type	Circuit Length [km]	Number of Outages	Availability (%) 2015	Availability (%) 2016
110 kV Circuits	4248	387	95.17	90.77
220 kV Circuits	1924	80	95.01	94.07
275 kV Circuits	97	3	98.18	98.18
400 kV Circuits	439	8	93.58	94.46
Plant Type	Transformer Capacity [MVA]	Number of Outages	Availability (%) 2015	Availability (%) 2016
220 / 110 kV Transformers	9927	71	92.02	94.94
275 / 220 kV Transformers	1200	2	97.52	99.81
400 / 220 kV Transformers	3550	13	93.73	96.7
Total	6708 km	564	95.03	95.56
	14677 MVA			

In 2016:

- The average plant availability was 95.56%;
- The maximum availability by plant type was 99.81%, which occurred on the 275kV tie lines; and
- The minimum availability by plant type was 90.78%, which occurred on the 110kV feeders.

4.7.3 Cause of Transmission Plant Unavailability

Transmission plant unavailability is classified into the categories outlined in Table 9.

Table 9: Transmission System Plant Unavailability Categories

Category	Description
Forced & Fault	Refers to unplanned outages. An item of plant trips or is urgently removed from service. Usually caused by imminent plant failure. There are three types of forced outage: A) Fault & Reclose B) Fault & Forced C) Forced (No Tripping) The above forced outages are explained in detail in Section 6.6.
Safety & System Security	Safety: Refers to transmission plant outages which are necessary to allow for the safe operation of work to be carried out. System Security: Refers to outages which are necessary to avoid the possibility of cascade tripping or voltage collapse as a result of a single contingency. When a line is out for maintenance it may be necessary to take out additional lines for this reason.

New Works	An outage to install new equipment or uprate existing circuits.
Category	Description
Corrective & Preventative Maintenance	<p>Corrective Maintenance: Is carried out to repair damaged plant. Repairs are not as urgent as in the case of a forced outage.</p> <p>Preventative Maintenance: Is carried out in order to prevent equipment degradation which could lead to plant being forced out over time. Includes line inspections, tests and routine replacements.</p>
Other Reasons	A number of other reasons may be attributed to plant unavailability, such as testing, protection testing and third party work.

4.7.4 110 kV Plant Unavailability

Figure 9 provides a breakdown of the causes of unavailability on the 110 kV network in 2016.

The largest contributor to unavailability (42%) on the 110 kV network in 2016 were outages for the purpose of Corrective and Preventative Maintenance. This type of maintenance includes, amongst others, Ordinary Services, Condition Assessments, wood-pole replacement/straightening and general line maintenance. The most significant of these, was the outage of the Arva Shankill 2 110kV Circuit, which lasted 176 days. This was to facilitate maintenance on the associated cubicles and also to facilitate the uprating of Arva Shankill 2 110kV Circuit.

A further 16% of unavailability on the 110 kV network was attributable to the "New Works" category. This category is for outages to install new equipment or uprate existing circuits. The most significant of these was the outage of the 1 Flagford Lanesboro 10 kV line. The purpose of this outage was to facilitate the looping in of Sliabh Bawn 110kV station.

Figure 9: Causes of Unavailability on the 110kV System in 2016

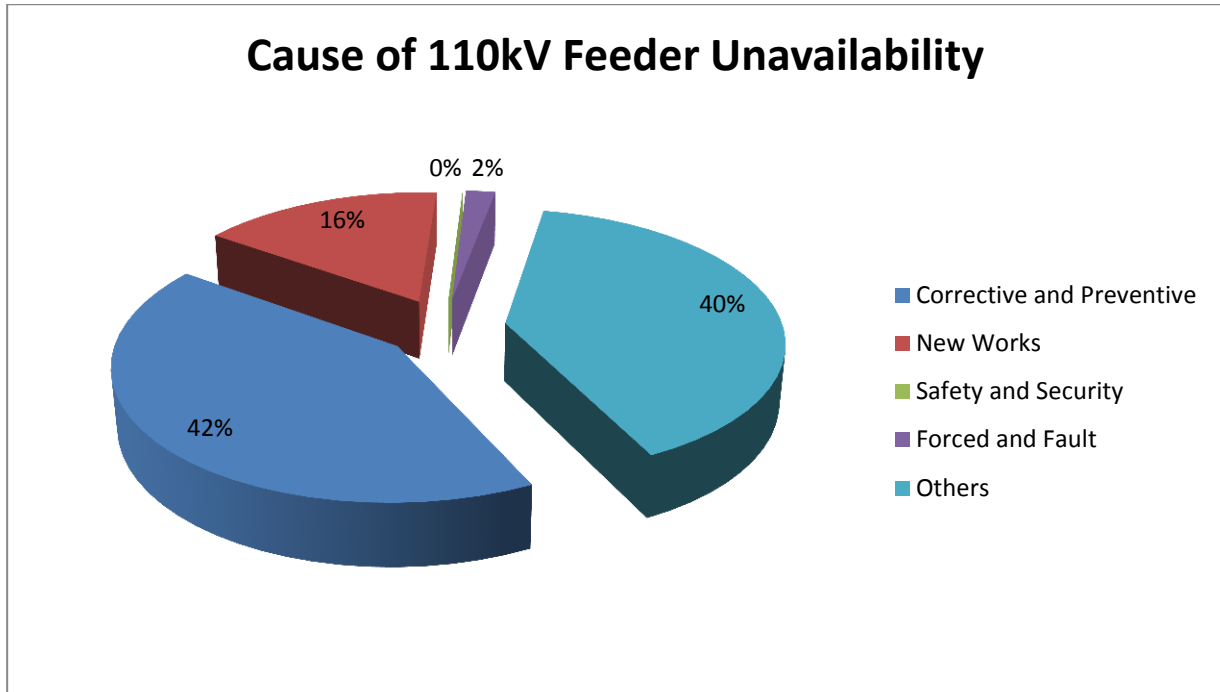

4.7.5 220 kV Plant Unavailability

Figure 10 provides a breakdown of the causes of unavailability on the 220 kV network in 2016.

The largest contributor to unavailability (51%) on the 220 kV network in 2016 were outages for the purpose of Corrective and Preventative Maintenance. The most significant of these was the outage of the Ballyvouskill Clashavoon 220kV circuit for 70 days. The purpose of this was tower foundation uprating.

Approximately 43% of unavailability on the 220 kV network was attributable to New Works. The most significant of these outages was on the Ballyvouskill Tarbert 220 kV line which lasted 149 days. The purpose of this was the looping in of Knockanure 220kV station.

Figure 10: Causes of Unavailability on the 220kV System in 2016

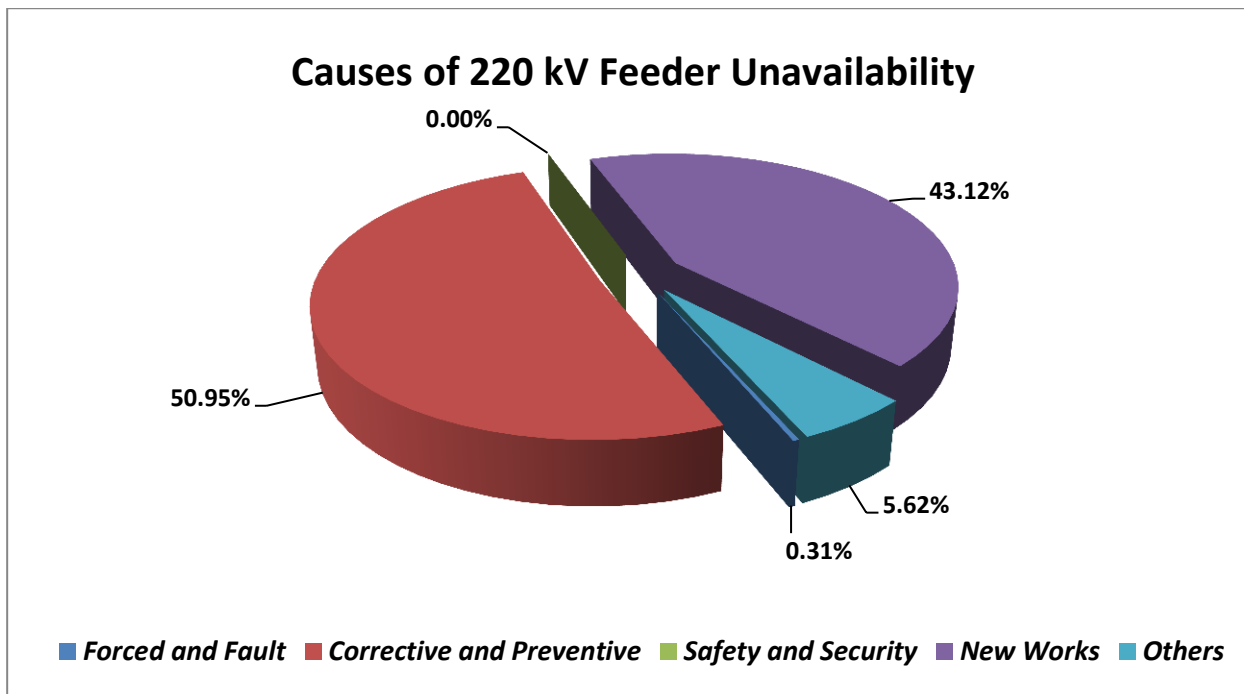

4.7.6 275 kV Plant Unavailability

The 275 kV tie-line consists of 48.5 km of 275 kV double circuit between Louth station and Tandragee station which is situated in County Armagh. In 2016 there was only 1 outage of 275 kV tie-lines, all of which were for corrective and preventative maintenance. This 13 day outage of Louth - Tandragee 2 (TWO) 275 kV Line was to facilitate maintenance.

4.7.7 400 kV Plant Unavailability

Figure 11 provides a breakdown of the causes of unavailability on the 400 kV network in 2016.

The largest contributor to unavailability (99%) on the 400 kV network in 2016 were corrective and preventative outages. The most significant of these was a maintenance outage of the Oldstreet - Woodland 400kV line. This 13 day outage of Oldstreet - Woodland 400kV line was to facilitate corrective and preventative maintenance.

Figure 11: Causes of Unavailability on the 400kV System in 2016

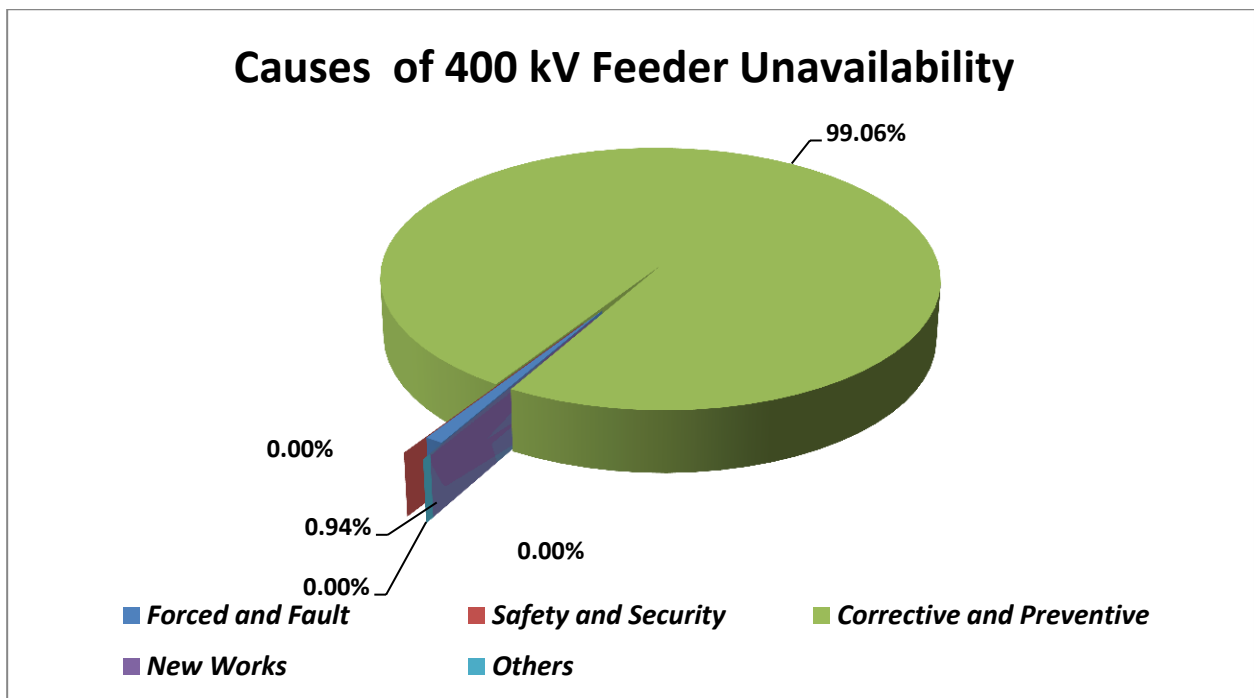

Table 10 provides a breakdown of the transmission system outages that occurred in 2016 by plant type.

Table 10: Transmission System Plant Outage 2016

Plant Type	No. of Items	Circuit Length	Forced & Fault	Safety & System Security	New Works	Corrective & Preventive Maintenance	Other	Total No. of Outages
110 kV Circuits	387	4248	11	0	51	220	105	387
220 kV Circuits	1924	1927.1	7	0	13	42	18	80
275 kV Circuits	2	97	0	0	0	1	0	1
400 kV Circuits	4	439	1	0	0	7	0	8
Total	264	6711	19	0	64	270	123	476
Plant Type	No. of Items	Transformer Capacity	Forced & Fault	Safety & System Security	New Works	Corrective & Preventive Maintenance	Other	Total No. of Outages
220 / 110 kV Trafos	39	9927	5	0	15	34	17	71
275 / 220 kV Trafos	3	1200	0	0	0	2	0	2
400 / 220 kV Trafos	5	3550	4	0	0	9	0	13
Total	47	14677	9	0	15	45	17	86

4.8.8. East West Interconnector Unavailability

Figure 12: Causes of East West Interconnector Unavailability in 2016

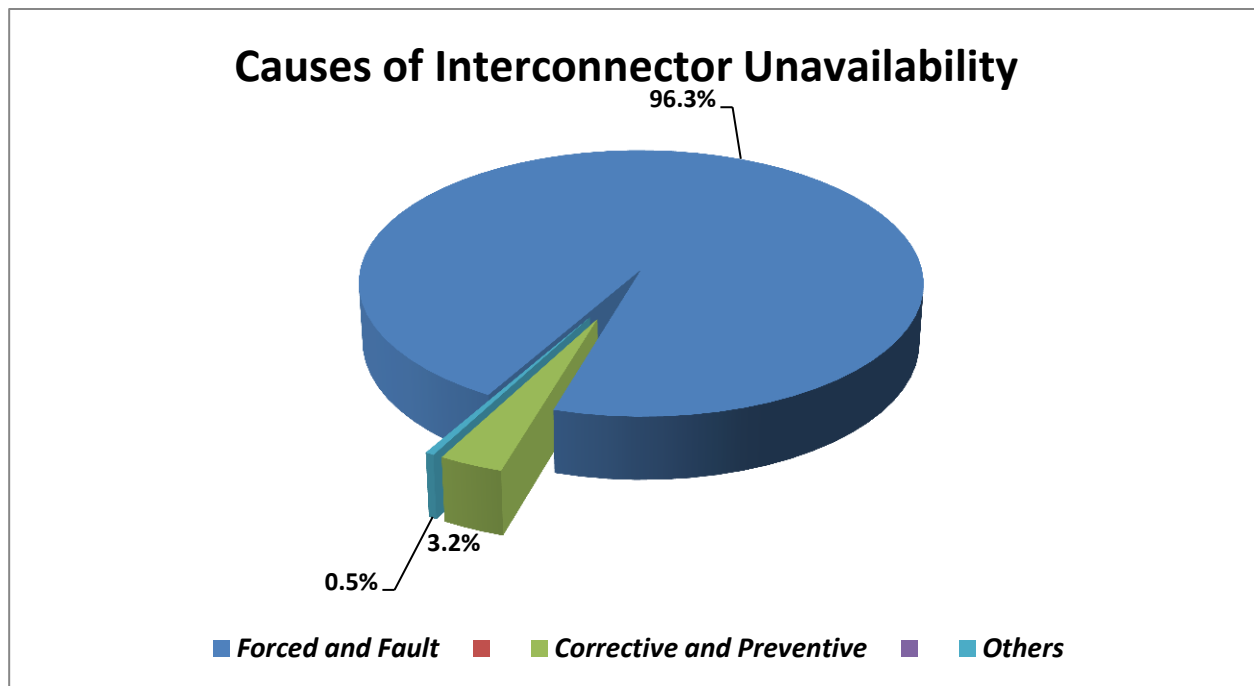

In 2016 the availability of the East West Interconnector was 70%. Of the outages contributing to EWIC unavailability, Forced & Fault represented the largest portion (96%), the longest of which was a 75 day outage following a trip.

4.7.8 Transmission Outage Duration

The duration of transmission outages is useful for assessing transmission system performance. Transmission outages are broken into eight time classifications ranging from less than 10 minutes to greater than four weeks. The total number of outages in each time classification is shown in Figure 13.

Figure 13: Duration of Outages in 2015 & 2016

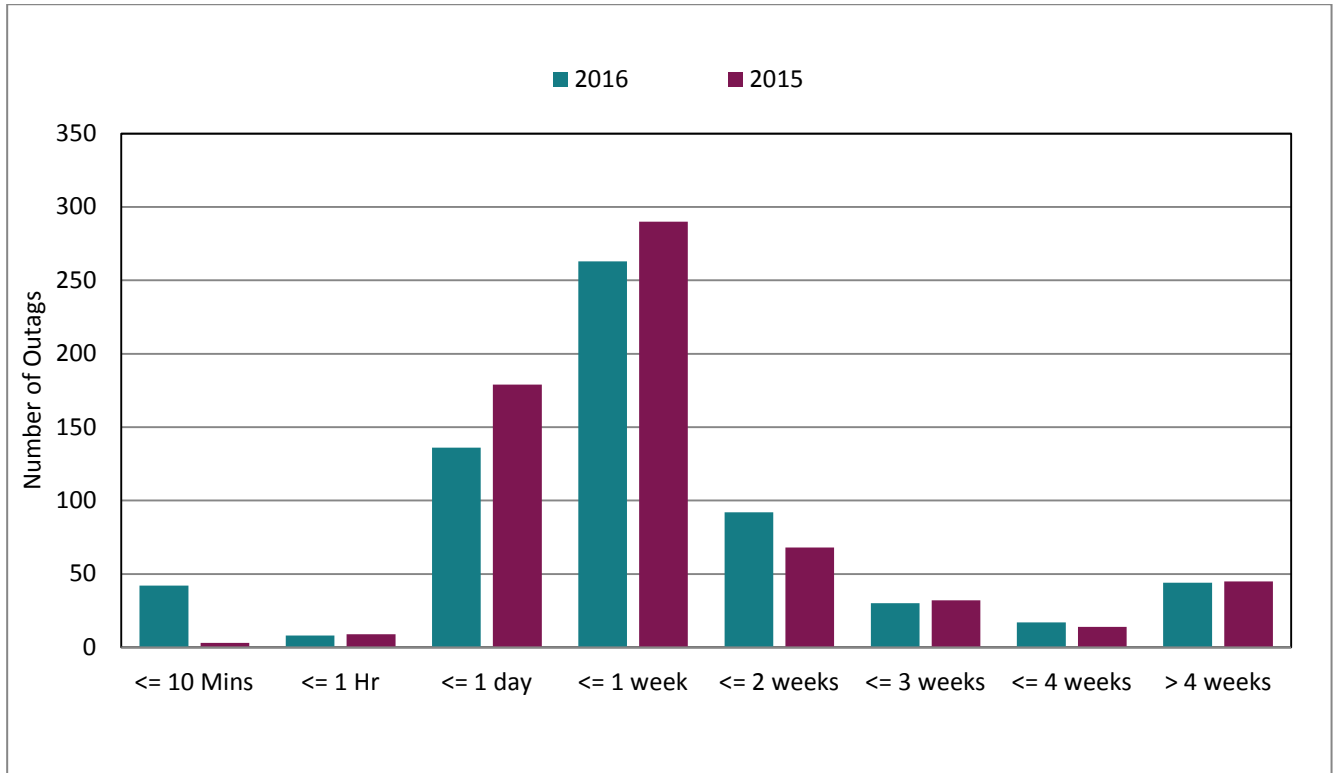

The two most frequent transmission system outage periods occur between one hour and one day and between one day and one week. In the category of one hour to one day, outages can be arranged to avoid peak load times and thereby reduce the impact on the system, while one week outages for annual maintenance are commonplace during the Outage Season.

4.7.9 Timing of Transmission Outages

Transmission outages are scheduled, where possible, during periods of low load in the summertime (however, this can be limited by a number of factors such as personnel availability and shortage of hydro-power support in some areas). The seasonal nature of transmission outages is apparent in

Figure 14 shows the percentage unavailability of the transmission system in each month. The March-October period (known as the Outage Season) sees the highest rates of unavailability during the year, when decreased system load is taken advantage of to carry out extensive maintenance outages such as the 43 day outage to refurbish the Bandon-Raffeen 110KV Line.

Figure 14: Percentage unavailability in each month of 2015 & 2016

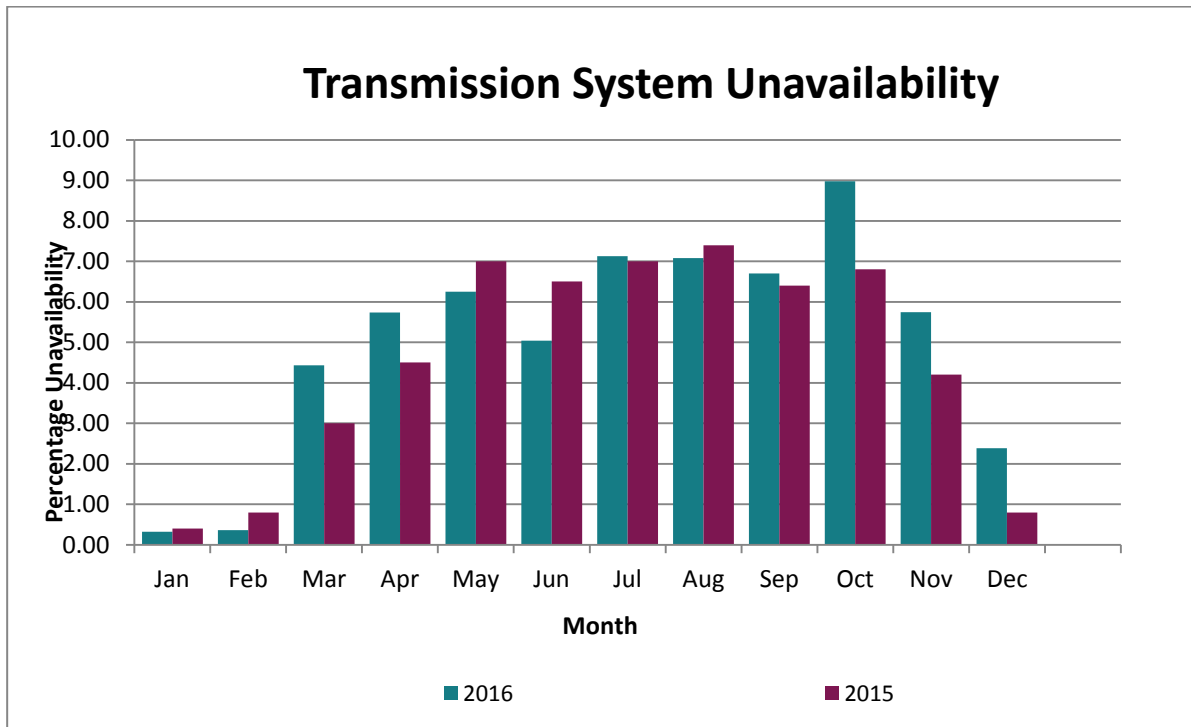
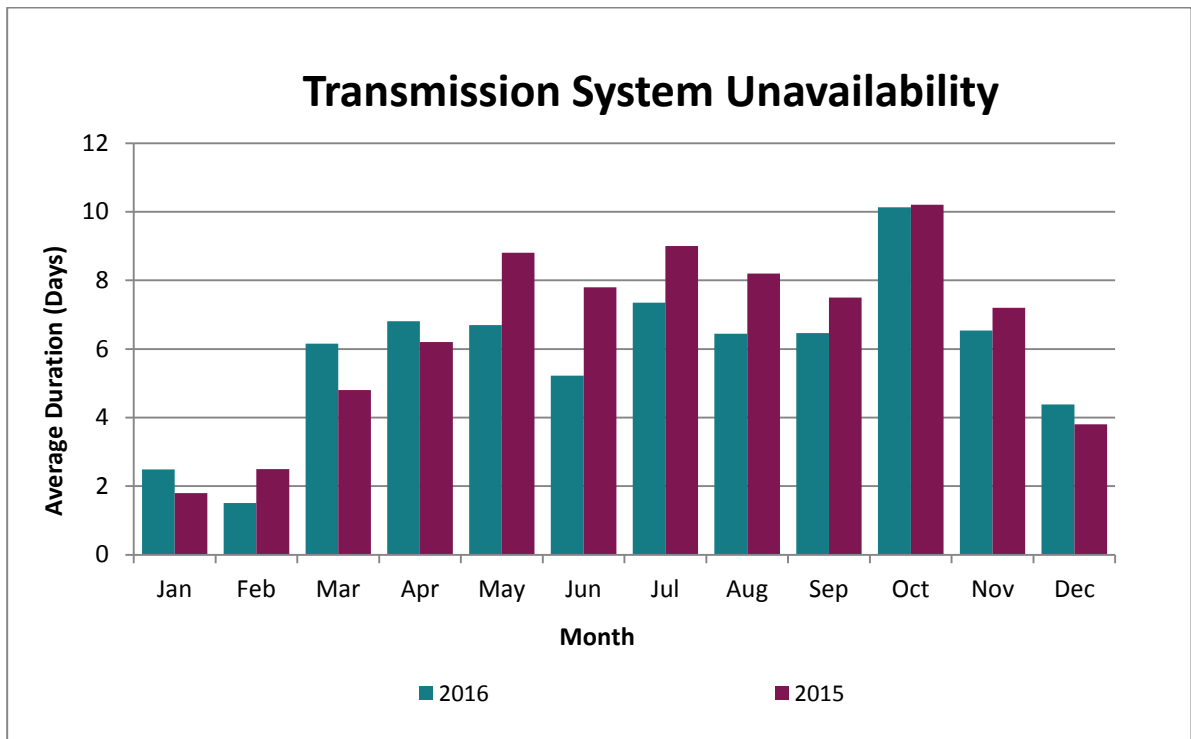

Figure 15: Average duration of outages 2015 & 2016



4.7.1 Forced Outages

There are two main outage classifications, voluntary outages and forced outages. The majority of outages are voluntary outages that are scheduled by EirGrid. Forced outages are not scheduled and cause the most disruption to the transmission system. Due to their disruptive nature, forced outages merit further analysis.

4.7.2 Forced Outages per km

The measure used for analysing the forced outages of lines and cables is the number of forced outages per kilometre of feeder, and is shown in Figure 16.

Figure 16: Forced Outages in 2016



4.7.3 Forced Outages per MVA

The measure used for analysing the forced outages of transformers is the number of forced outages per MVA capacity, which can be seen in Figure 17.

Figure 17: Transformer Forced Outages in 2016

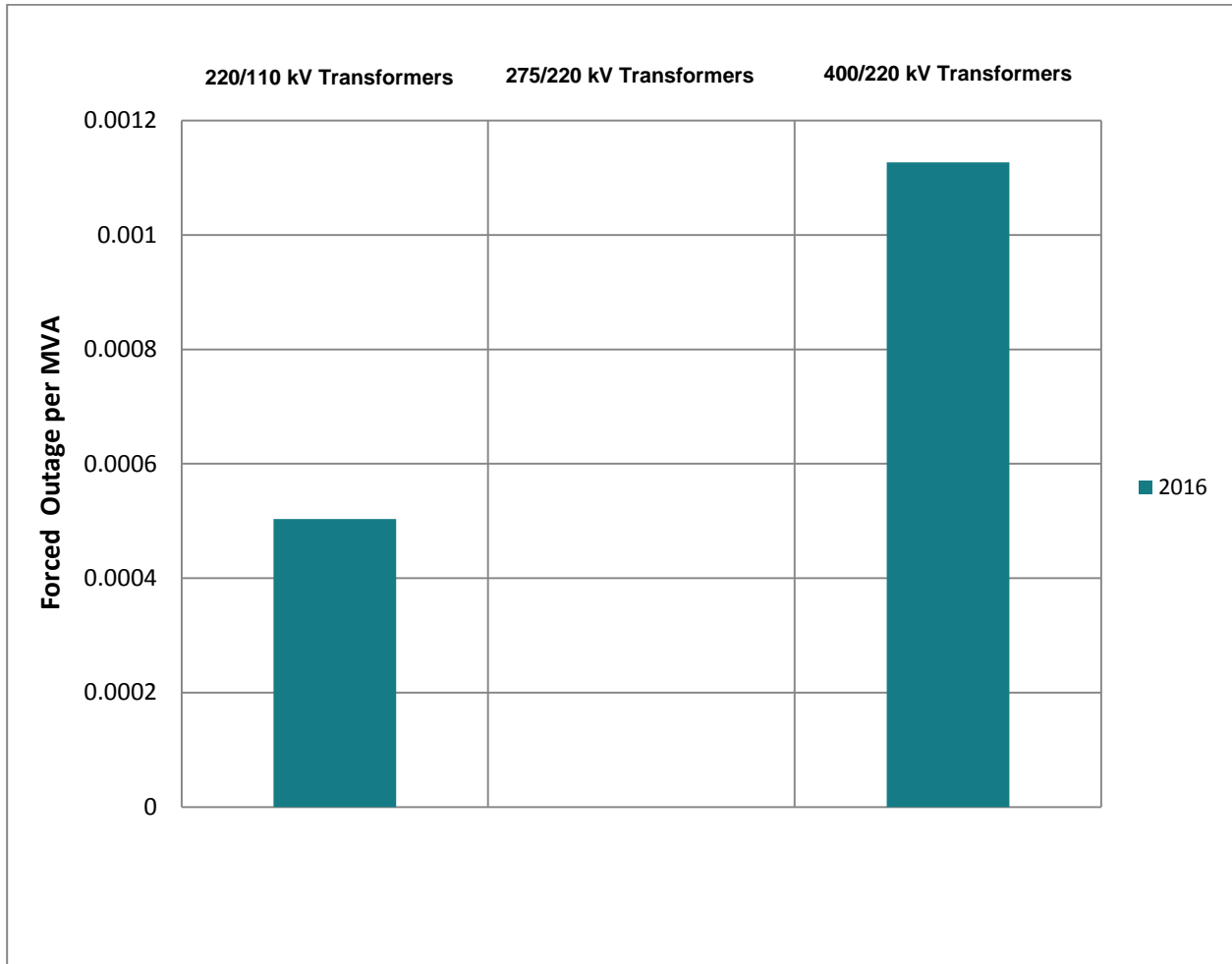

5. SONI Transmission System Performance

This section details the performance of the transmission system in Northern Ireland, unless explicitly stated otherwise. This data has been prepared by SONI in accordance with Condition 20 of the 'Licence to participate in the Transmission of Electricity'.

5.1 Summary

SONI is responsible for the safe, secure, efficient and reliable operation of the Northern Ireland transmission network. The transmission network is operated at 275 kV and 110 kV and is made up of approximately 150 circuits covering a total length of approximately 2130 km. The primary purpose of the transmission system is to transport power from generators and interconnectors to bulk supply points which connect the transmission system to the distribution system.

Availability is a key measure of power system performance. In this report availability refers to the proportion of time a transmission circuit or interconnector was available.

The annual system availability for 2016 was 96.64 %. Ongoing project work was completed in 2016 which consisted of refurbishment work at 110 kV substations across Northern Ireland. A number of new 110 kV substations were commissioned in 2016 to facilitate the connection of wind energy. These included Gort, Rasharkin and Tremoge 110 kV substations.

The annual availability of the Moyle Interconnector for 2016 was 59.04 %. This figure was boosted by activities by the asset owner, Mutual Energy. They completed a project to restore the interconnector to full capacity. This included the replacement of the LV conductors associated with both submarine cables. This availability also included a prolonged outage of the overhead line on the Scottish system. National Grid, in conjunction with Scottish Power, completed a project to increase the capacity of the Auchencrosh-Coylton 275 kV overhead line.

In relation to the connections between Northern Ireland and Ireland the North-South 275 kV tie line had an availability of 96% in 2016. The two 110 kV tie lines had an annual availability of 97% and 100%.

The Electricity Safety, Quality and Continuity Regulations (Northern Ireland) 2012 set out the statutory obligations in relation to managing both frequency and voltage for Northern Ireland. Under the regulation SONI are required to report incidents which have caused interruptions to supplies to customers to the transmission asset owner, NIE Networks. Part 8, paragraph 33 of the regulation contains details of the requirements for the reporting of incidents.

In 2016, there were three transmission incidents leading to customers being off supply. These were;

- On the 07 June 2016 at 00:52, an incident at Lisburn Main substation resulted in the loss of supply to 34,602 customers. The system minutes lost for this event was 0.134.
- On the 07 June 2016 at 01:32, an incident at Lisburn Main substation resulted in the loss of supply to 34,602 customers. The system minutes lost for this event was 0.024.
- On the 20 July 2016, an incident at Kells 110 kV substation resulted in the loss of supply to 71,333 customers. The system minutes lost for this event was 1.548.

Quality of service is measured by the number of voltage and frequency excursions which fall outside statutory limits. There were no voltage excursions in 2016 outside the statutory limits.

The nominal frequency of the all-island transmission system is 50 Hz, and is normally controlled within the range of 49.95 Hz and 50.05 Hz. SONI are required to report on system faults where the frequency drops below 49.8 Hz or above 50.2 Hz. In 2016, there were 42 system events where the frequency exceeded these limits.

The reporting of frequency excursions is carried out in accordance with the definitions and principles of the National Fault and Interruption Reporting Scheme (NAFIRS), (Engineering Recommendation G43/2). The effects of national / regional emergencies and disputes are excluded.

5.2 Transmission System Availability

Transmission system availability is the proportion of time a transmission circuit was available during the calendar year. A circuit is defined as the overhead line, cable, transformer or any combination of these that connects two busbars together or connects

the transmission system to another system. Transmission system availability is reduced when a circuit is taken out of service, either for planned or unplanned purposes.

Planned outages are necessary to facilitate new user connections, network development and maintenance of network assets necessary to deliver acceptable levels of system security and reliability. These are outages planned with at least seven days notice.

Unplanned outages can be a result of equipment failure or a fault caused by adverse weather etc. These are outages required immediately or planned with at less than seven days' notice.

System Availability is calculated using the formula:

Equation 1: System Availability Formula

$$\text{System Availability (\%)} = \frac{\sum \text{Hours each circuit is available}}{(\text{No. of Circuits}) * (\text{Total No. Hours in Period})}$$

In 2016, the analysis of the transmission system availability data has produced the following results:

- The average availability of the Northern Ireland transmission system was in 2016 was 96.44%,
- The average winter system availability (for the winter months January, February, November and December 2016) was 98.46%.

Figure 18 below shows the month by month variation in system availability of the transmission network in Northern Ireland.

Figure 18: Transmission System Availability 2016

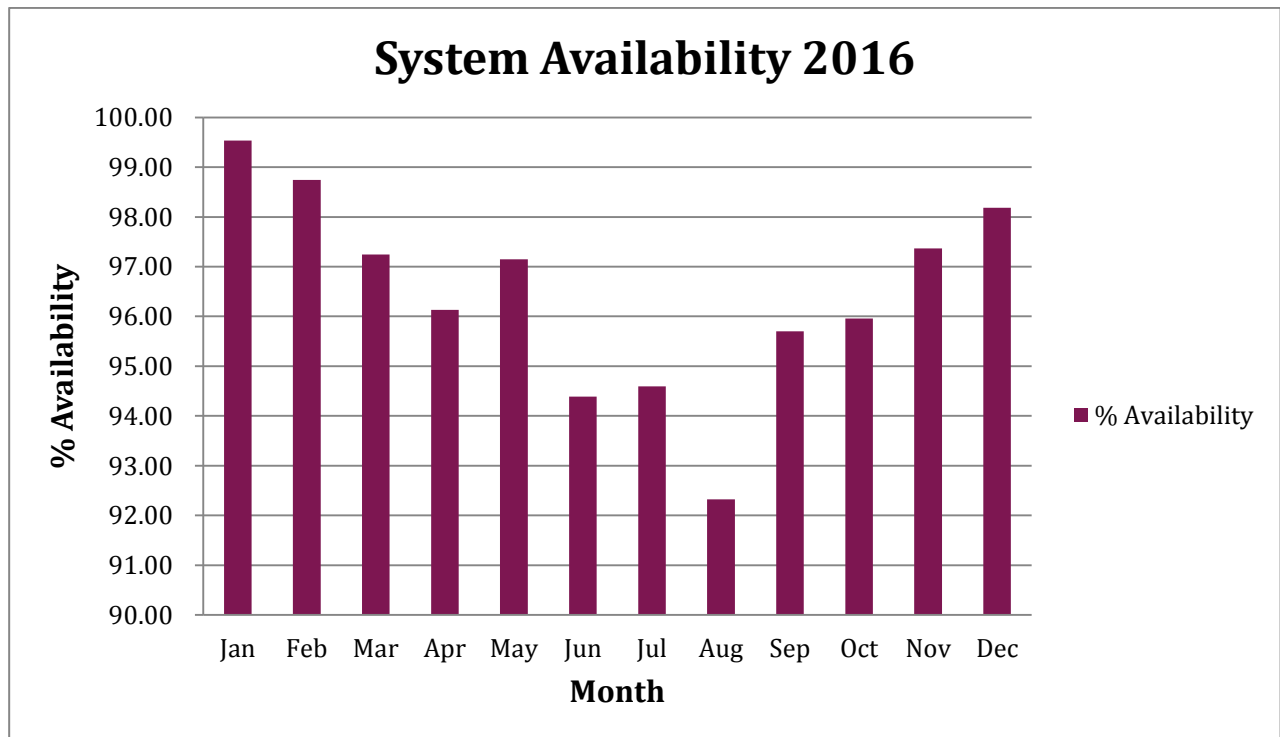

Overall, the availability of the system is high, particularly over the winter months where maintenance is avoided due to the higher electrical demand and potential adverse weather conditions. The preference is for maintenance to take place over the summer months when network loading is generally lower to mitigate the risk of affecting the supply to customers.

5.2.1 System Unavailability

Figure 19 below shows the month by month variation in planned and unplanned system unavailability.

Figure 19: Transmission System Unavailability 2016

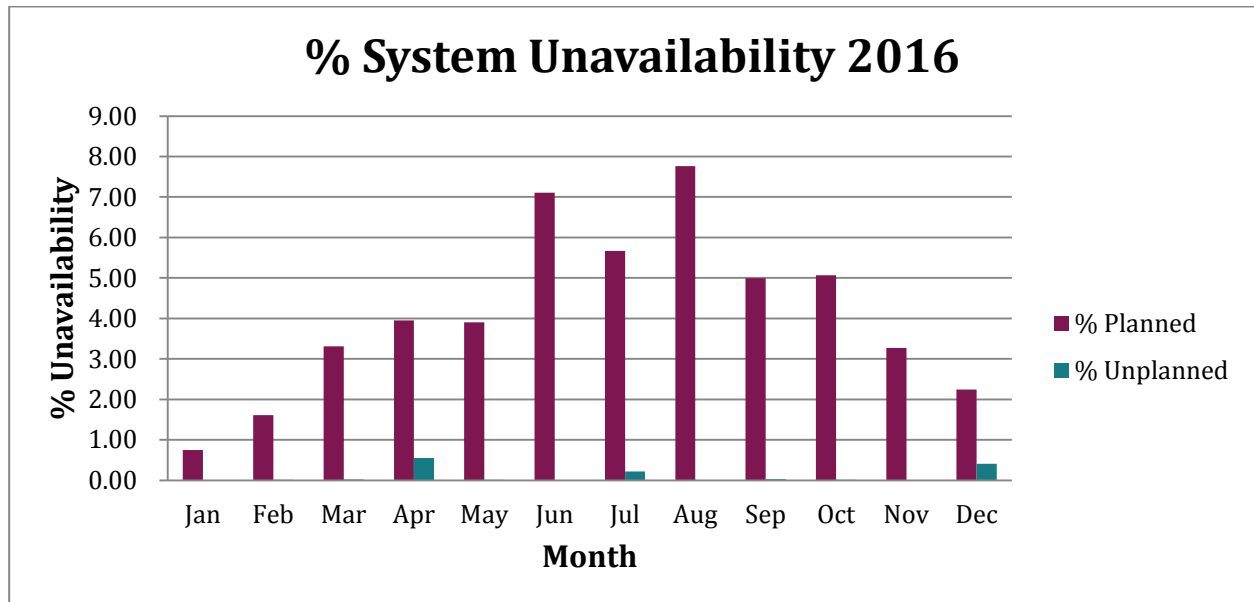

The majority of outages occurred during the spring/summer months. This reflects the policy of planning outages during periods of lower electrical demand.

5.2.2 System Historic Availability Performance

Figure 20 shows the historic variation in system availability from 1999 to 2016 for the transmission network in Northern Ireland.

Figure 20: Historic System Availability 1998-2016⁵

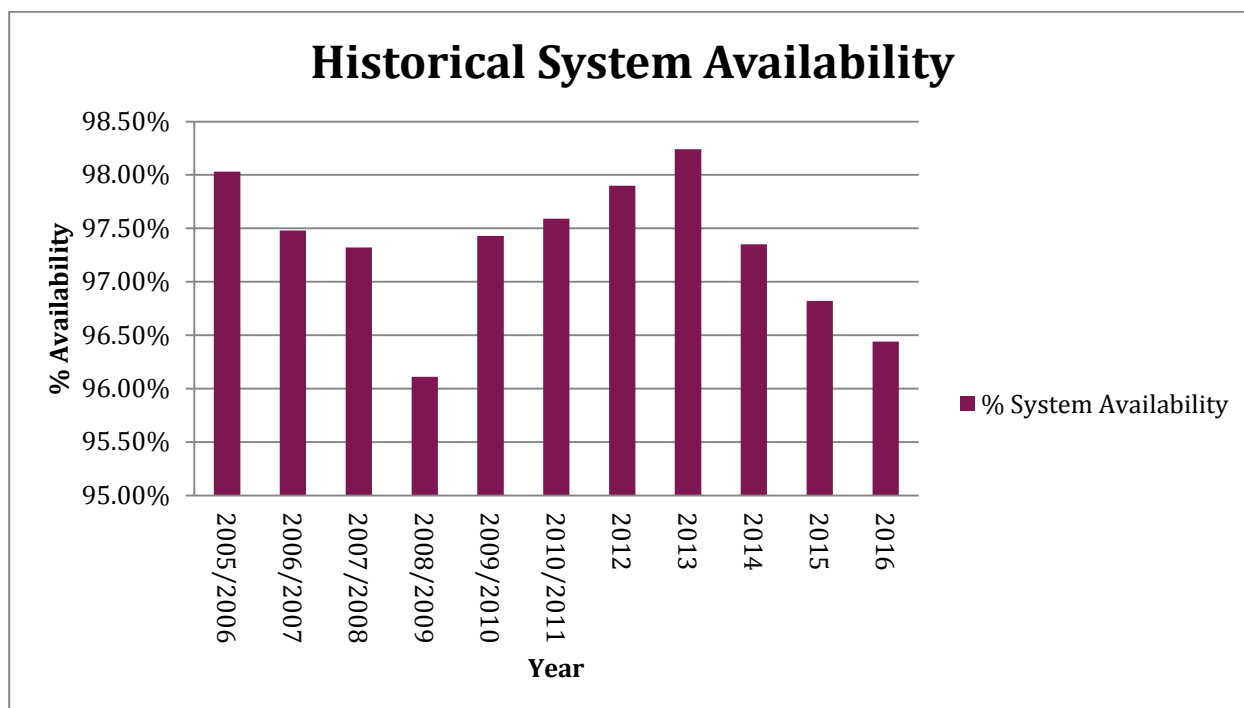

5.2.3 System Historic Unavailability Performance

Figure 21 below shows the breakdown of the system unavailability from 1999/2000 to 2016.

Figure 21: Historic System Unavailability 2005-2016

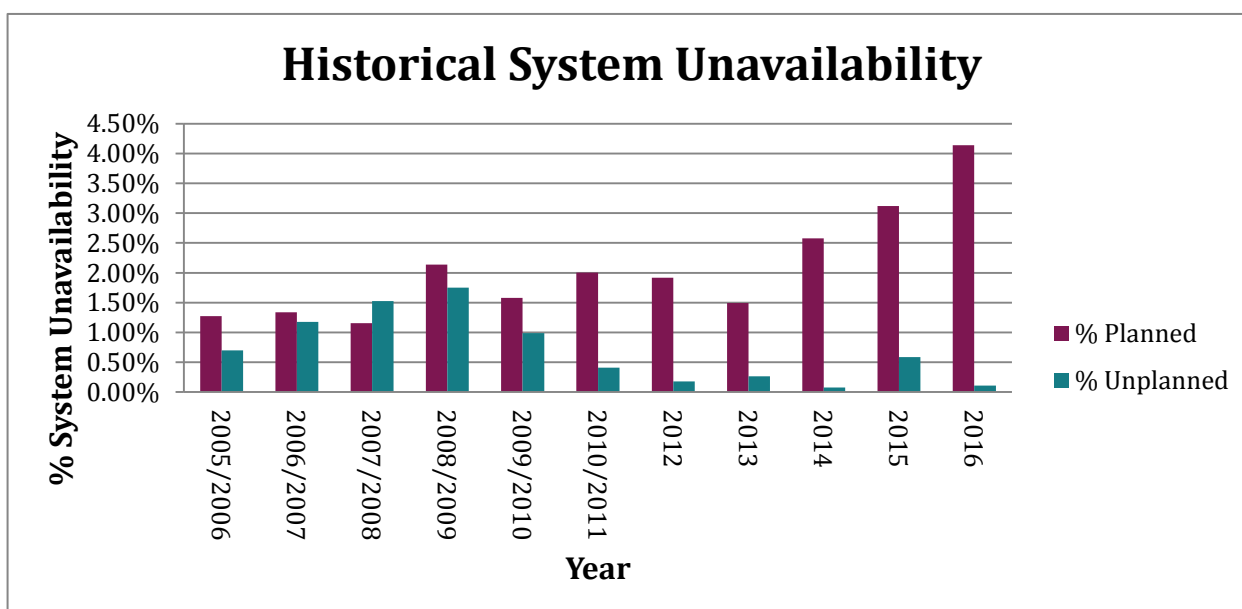

The year on year increase in system unavailability from 2013 – 2016 is representative of the commitment NIE Networks have made as part of price control RP5 in upgrading existing infrastructure as well as constructing new assets to meet the ongoing changes of the power system. Examples of this include;

- New cluster substations (Gort, Rasharkin, Tremoge)
- 110 kV Substation Refurbishment works (Castlereagh, Kells, Tandragee 110 kV Substations)
- Belfast North Main, new 110/33 kV substation
- Kells-Coleraine overhead line uprate

5.3 Interconnector and Tie-Line Availability

5.3.1 Moyle Interconnector

The Moyle interconnector, owned by Mutual Energy, connects the power systems of Northern Ireland and Scotland. The interconnector is a High Voltage Direct Current (HVDC) system; consisting of two submarine power cables and two HVDC-AC converter stations; one located at Islandmagee in Northern Ireland and the other at Auchencrosh in Scotland. The system has an operational import capacity of 442 MW and an operational export capacity of 300 MW. The interconnector is operated by SONI, and the performance of the interconnector is detailed in this report.

In 2012, a cable fault occurred limiting the capacity of the interconnector to 250 MW. A project was completed in 2016 to restore the interconnector to full import/export capacity. This involved the laying of two new LV submarine cables to replace the integrated return conductor of the existing cable.

Scottish Power also completed a project to upgrade the overhead line on the Scottish side from June to September. This resulted in a zero import/export capacity on Moyle.

5.3.2 Moyle Interconnector Historic Availability

The Annual Availability of the Moyle Interconnector for 2016 was 49.62%.

Figure 22: Historic Moyle Interconnector Availability 2002/03 - 2016

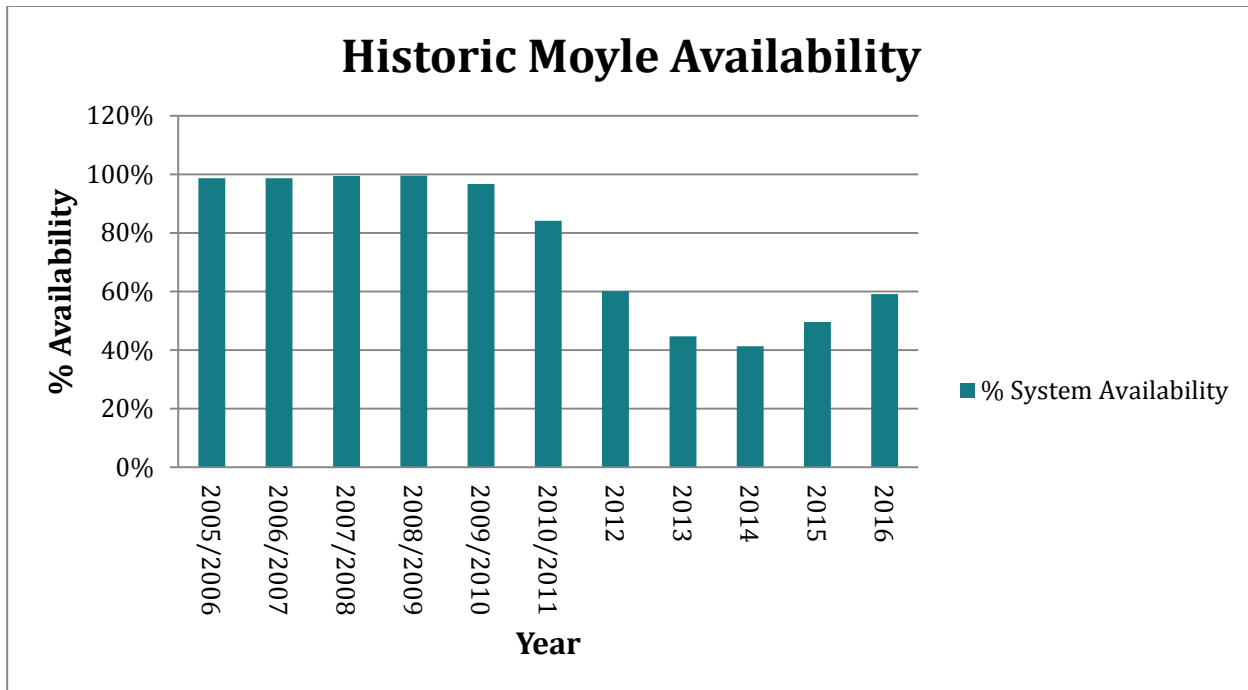

5.3.3 Moyle Interconnector Historic Unavailability

The 2016 Annual Unavailability of the Moyle Interconnector was 40.96%.

Figure 23: Historic Moyle Interconnector Unavailability 2005-2016

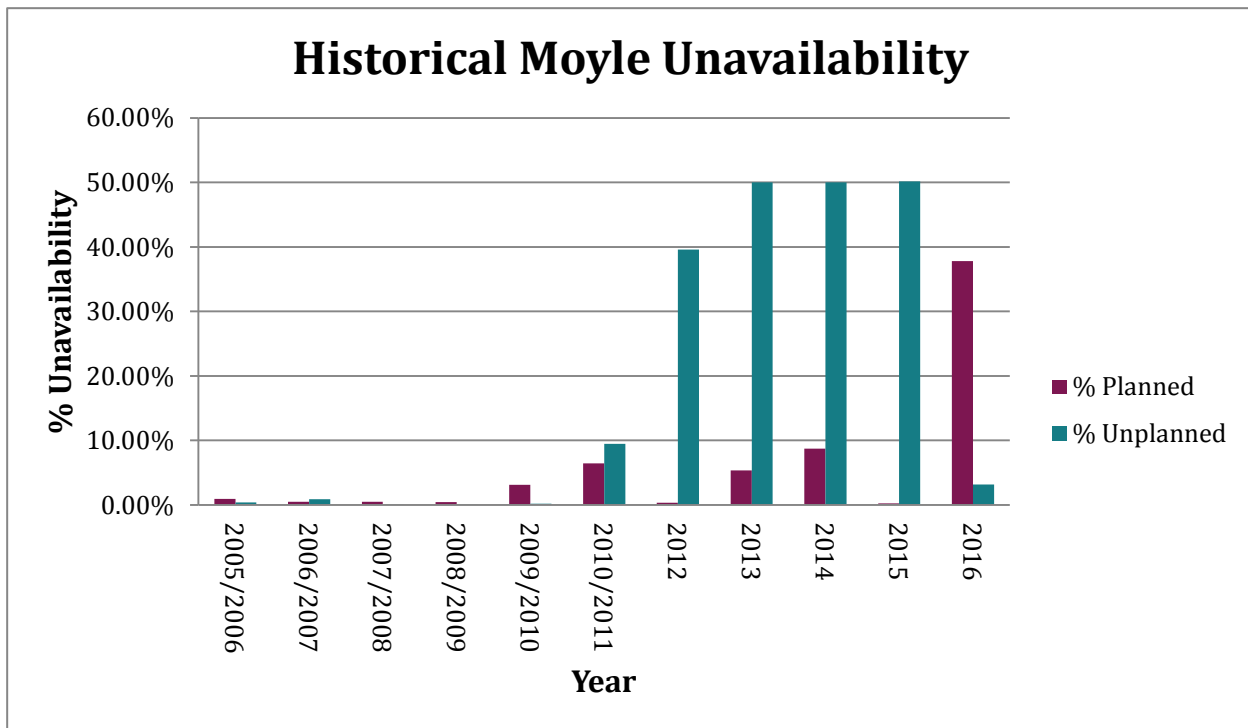

5.3.4 Moyle Interconnector Monthly Unavailability

Figure 24 below shows the month by month variation of unavailability of the interconnector.

Figure 24: Moyle Interconnector Unavailability 2016

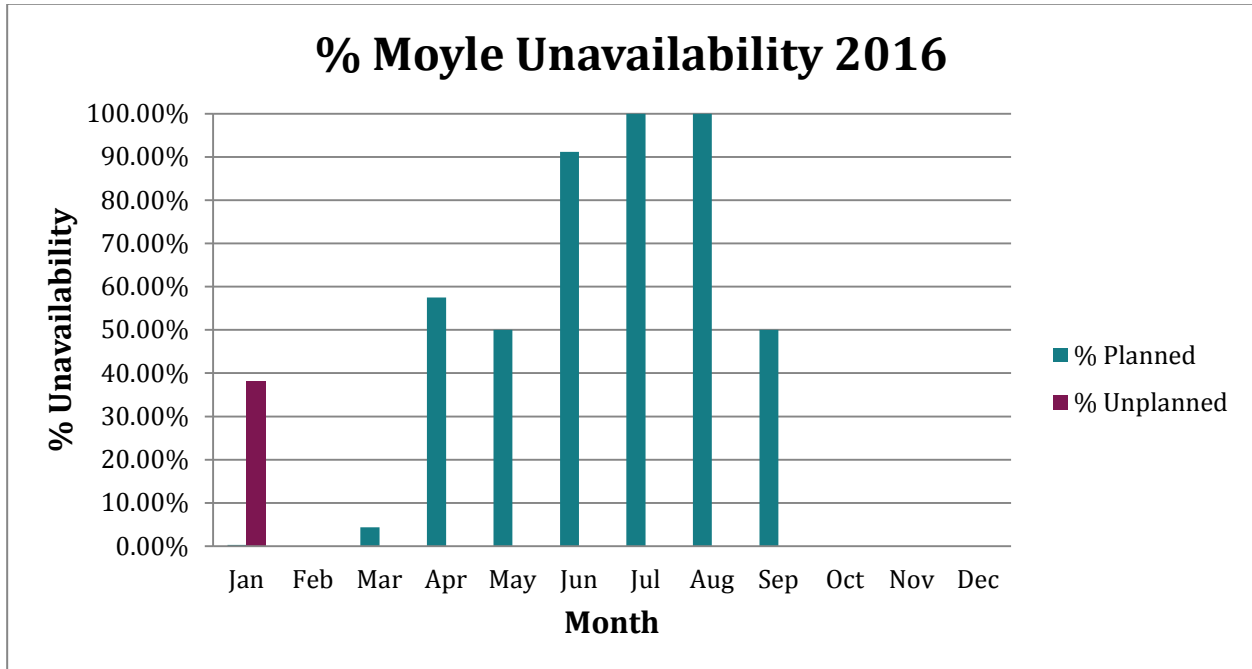

Outages were required by the asset owner in the early months of the year as part of a project to return the interconnector to full capacity. The asset owner, Mutual Energy, completed a project to install new low voltage submarine cables in parallel with the existing cables. These LV cables form key components in the make-up of the HVDC system.

The interconnector was unavailable from June until September due to an outage of the Auchencrosh-Coylton 275 kV overhead line. Scottish Power, the transmission asset owner in the south of Scotland, completed an overhead line re-string to increase the capacity of the circuit. This project took 3 months to complete.

5.3.5 275 kV Tie Line

The connections between Ireland and Northern Ireland are referred to as 'Tie Lines'.

The Northern Ireland transmission system is connected to the transmission system in Ireland by means of one 275 kV double circuit connection from Tandragee 275 kV substation in Co. Armagh to Louth 220 kV substation in Co. Louth.

The 275 kV double circuit tie line is used as the method for synchronising the Northern Ireland and Ireland power systems together. Energy can flow freely between both jurisdictions, depending on the operating requirements and generating plant being utilised on the all island power system.

The annual average availability of the 275kV North-South Tie Line in 2016 was 96.31%.

Figure 25: Historic North-South Tie Line Availability 1995-2016

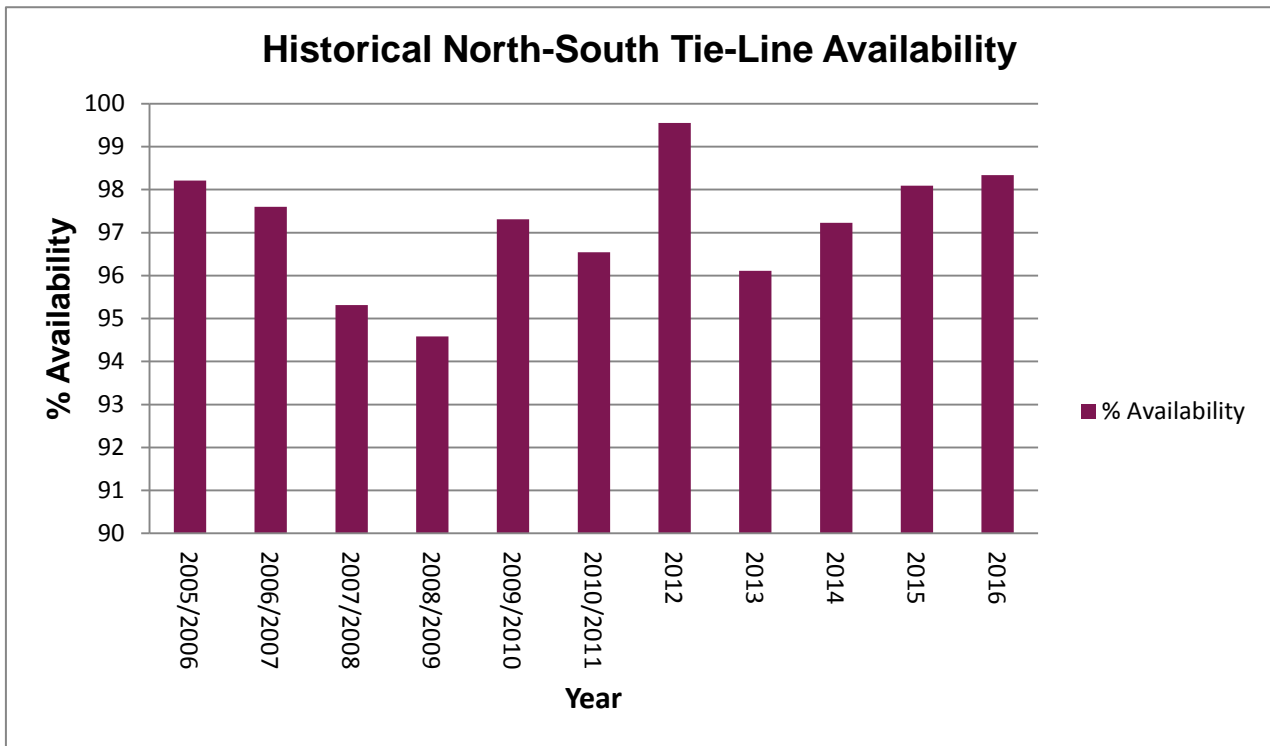

5.3.6 110kV Tie lines

There are two 110 kV connections between Ireland and Northern Ireland;

- Strabane – Letterkenny 110 kV circuit
- Enniskillen – Corraclassy 110 kV circuit

These 110 kV tie lines provide an AC connection between the two transmission systems, which allows emergency flows of active and reactive power for frequency and voltage support, increasing system stability.

Phase Shifting Transformers (PST), designed for energy to flow in two directions, are installed at Strabane and Enniskillen and control the flow of energy between Ireland and Northern Ireland. These PST’s are rated at 125 MW each and are, in normal operation, operated to maintain a 0 MW flow between both jurisdictions. To negate any potential

system abnormalities as a result of transmission outages, either scheduled or unplanned, a flow can be manually allowed that can support system operation in both jurisdictions.

Also, in times of high wind, the Strabane-Letterkenny tie line is used to import excess wind energy being produced.

The availability of the 110 kV Tie Lines was 98.69 in 2016.

Figure 26: North-South Tie Line Availability 2005-2016

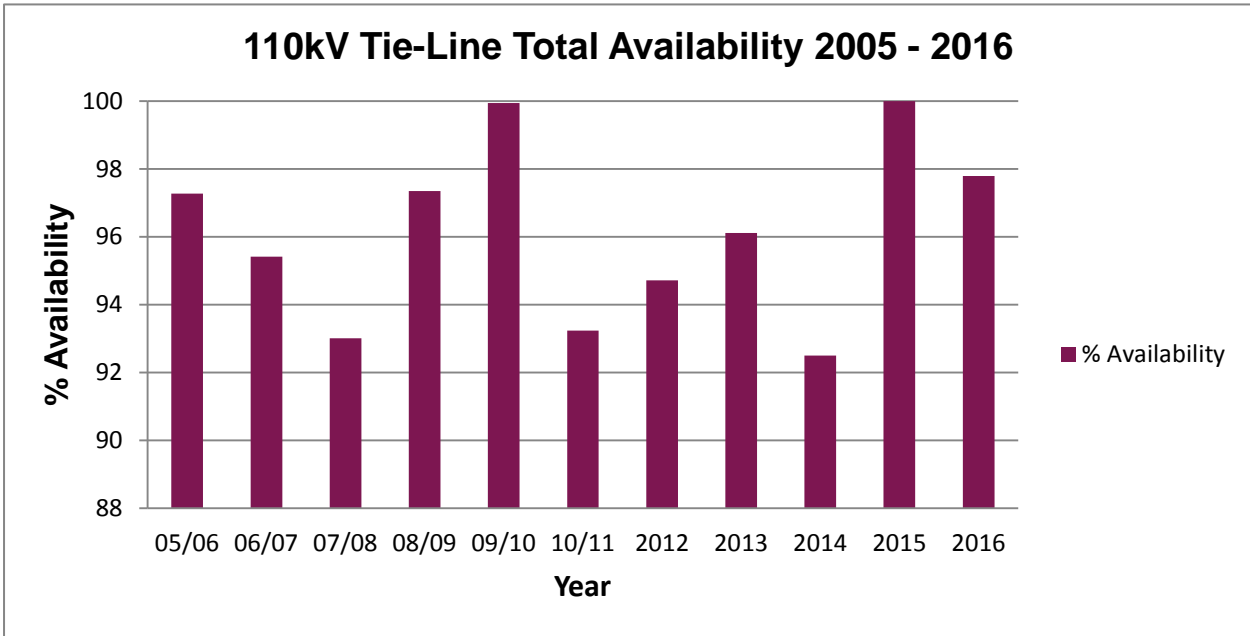

A breakdown of 110 kV tie line unavailability is shown in Figure 27 below.

Figure 27: Historic 110kV Tie Line Unavailability 2005-2016

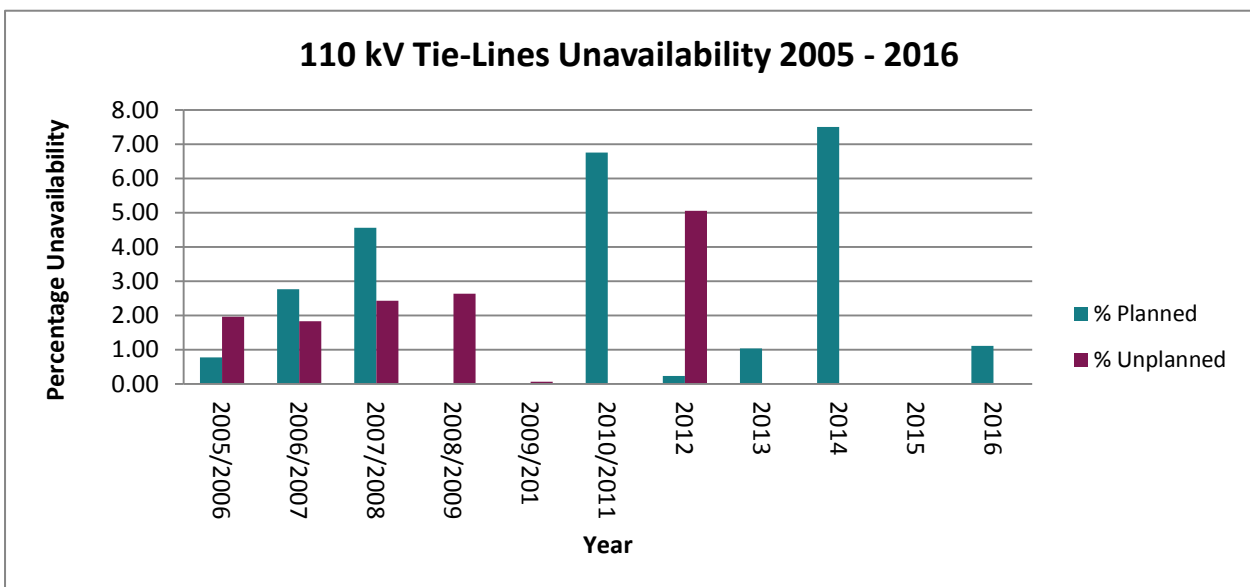

5.4 Transmission System Security

An incident is a system event that results in loss of supply. This section incidents resulting from issues on the Northern Ireland Transmission system are described individually. The following sections detail the nature, location and duration of the incidents with an estimate of energy unsupplied.

5.4.1 Incidents for 2016

The criterion for the reporting of incidents is specified in Part 8, paragraph 33, of 'The Electricity Safety, Quality and Continuity Regulations (Northern Ireland) 2012'. An incident shall be reported if there has been:

- any single interruption of supply, to any demand of 20 megawatts or more at the time of the interruption, for a period of three minutes or longer; or
- any single interruption of supply, to any demand of 5 megawatts or more at the time of the interruption, for a period of one hour or longer; or
- any single interruption of supply to 5,000 or more consumer's installations for a period of one hour or longer.

5.4.2 Number of Incidents and Estimated Unsupplied Energy

In 2016, there were three system events in Northern Ireland that resulted in the loss of supply to customers.

On the 7th of June 2016, an event occurred at Lisburn Main substation that resulted in the loss of 34,602 customers, equating to a total loss of 25 MW. All customers were fully restored within 9 minutes of the event happening.

On the 7th of June 2016, an event occurred at Lisburn Main substation that resulted in the loss of 34,602 customers, equating to a total loss of 20 MW. All customers were fully restored within 2 minutes of the event happening.

On the 20th of July 2016, a system event occurred at Kells 110 kV substation that resulted in the loss of 71,333 customers, equating to a total loss of 77 MW. All customers were fully restored within 47 minutes of the event happening.

5.4.3 Incident Analysis

Figure 28 details the incidents that have occurred historically in Northern Ireland.

Figure 29: Historic System Security 2005-2016

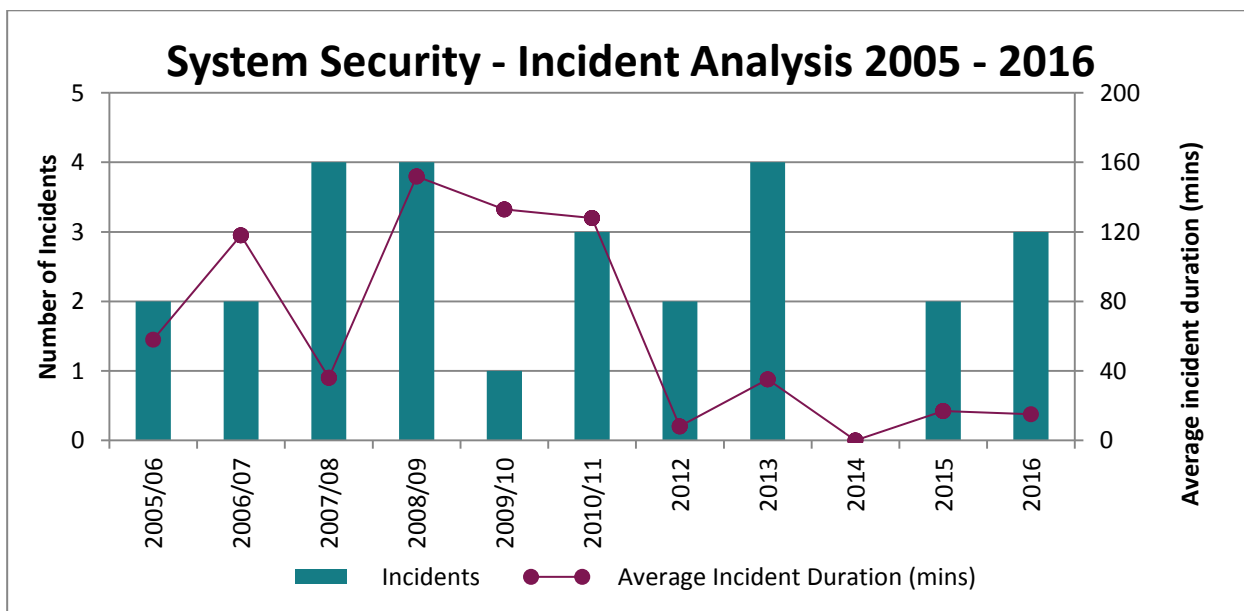

5.4.4 Unsupplied Energy

Figure 30 below shows the historic amount of unsupplied energy to Northern Ireland customers.

Figure 30: Historic Unsupplied Energy 2005-2016

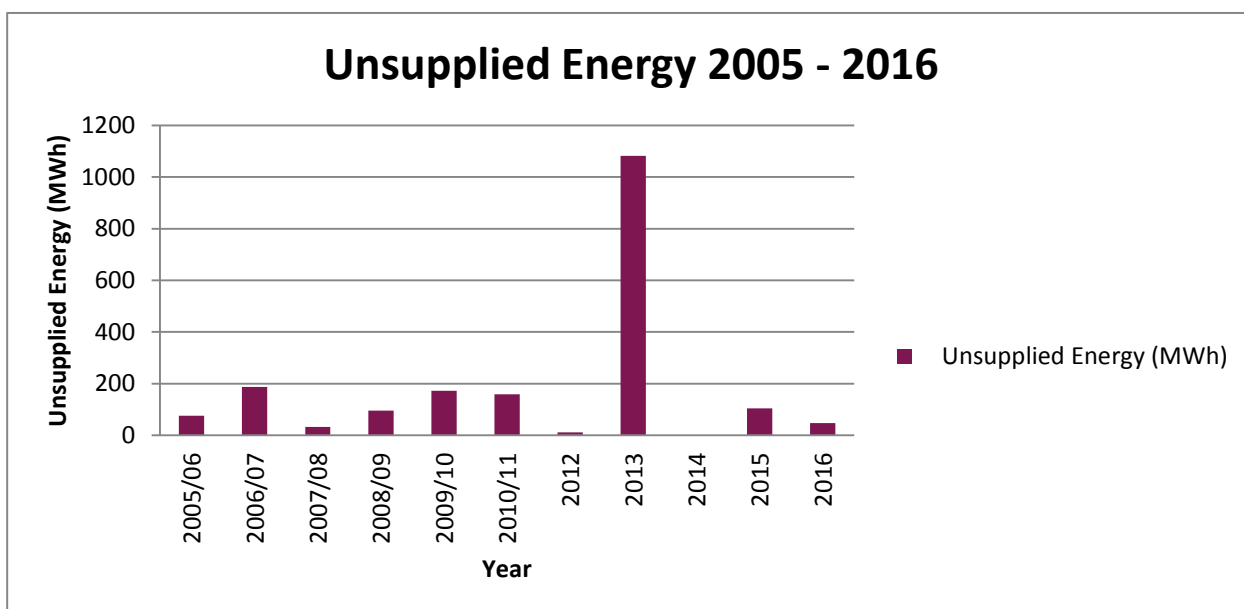

5.5 Quality of Service

Quality of service is measured with reference to system voltage and frequency.

5.5.1 Voltage

The Electricity Safety, Quality and Continuity Regulations (Northern Ireland) 2012 details the requirements for the management of voltage in Northern Ireland.

Part 7, paragraph 28 permit variations not exceeding 10 % for operating voltages of 110 kV or higher. As well as adhering to legislation, SONI also operate the transmission system in such a way as to comply with the Operating Security Standards⁶, acceptable step changes in voltages are detailed in Table 11.

Table 11: Voltage step change limits in operational timescales

Transmission System secured events or switching event	Voltage fall	Voltage rise
Following loss of single circuit	-6%	+6%
Following loss of double circuit overhead line	-10%	+6%

5.5.2 Voltage Excursions

There were no voltage excursions exceeding these limits in 2016.

5.5.3 Frequency

SONI are required to manage the frequency of the power system. Power system frequency is a measure of balance between the electrical demand on the network and the amount of energy being generated. The Electricity Safety, Quality and Continuity Regulations (Northern Ireland) 2012 details the requirements for the management of Frequency in Northern Ireland.

Part 7, paragraph 28 of the regulations permits a frequency variation of up to 0.5 Hz above or below 50 Hz. In line with previous publications this report contains details of frequency events where the frequency has dropped below 49.6 Hz or greater than 50.5 Hz. There were 10 reportable frequency excursions in Northern Ireland in 2016. Graphs in Appendix 2 contain traces of system frequency as well as raw and averaged rate of change of frequency data.

⁶ [SONI Operating Security Standards](#)

5.5.4 Frequency Excursions

Table 12: Frequency Excursions in 2016

Cause of Incident	Date	Time (UTC)	MW Lost	Pre-incident Frequency (Hz)	Nadir (Hz)	Min Frequency POR (Hz)	Rate of Change of Frequency		t<49.6 Hz seconds	t<49.5 Hz seconds	N-S Tie Line Flow MW
							Max df/dt Hz/Sec	Average df/dt Hz/Sec			
Great Island 4	09/04/2016	22:27:51	430	49.961	49.271	49.291	-0.51	-0.35	9.2	7.4	-141
Aghada Unit 2	12/04/2016	15:20:10	413	49.956	49.576	49.628	-0.23	-0.18	2.4	0	-47
Whitegate	24/04/2016	13:17:11	380	49.944	49.325	49.35	-0.46	-0.34	7.6	6	-74
Great Island 4	20/05/2016	20:51:41	440	50.017	49.228	49.235	-0.41	-0.35	10.9	9	5
Great Island 4	31/05/2016	13:59:29	420	49.959	49.229	49.241	-0.38	-0.29	8.6	7	20
Aghada Unit 2	05/06/2016	06:06:31	400	49.964	49.416	49.595	-0.41	-0.32	4.3	2.7	-3
Aghada Unit 2	09/06/2016	14:16:45	412	49.941	49.306	49.31	-0.42	-0.32	10.1	8.1	77
Huntstown Unit 2	17/07/2016	09:46:05	370	49.970	49.381	49.416	-0.53	-0.32	7	5.2	73
Great Island 4	03/09/2016	13:27:24	414	50.039	49.479	49.563	-0.41	-0.35	4.7	1.5	31
Huntstown Unit 2	11/09/2016	11:26:13	380	49.956	49.31	49.459	-0.4	-0.32	5.1	4.1	34

Note NS and Interconnection flows, +VE represents an import to Northern Ireland

Definitions

Time 0 seconds	Considered to be when the frequency falls through 49.8 Hz
Pre Incident frequency	Average system frequency between t – 60 seconds and t -30 seconds
Nadir (Hz)	Minimum system frequency from t 0 to t + 6 minutes
Minimum Frequency POR (Hz)	Minimum frequency during POR period from t + 5 seconds to t + 15 seconds
Max df/dt Hz/Sec	Maximum negative rate of change of frequency during the period t – 5 seconds to t + 30 seconds. (This is calculated from a five point moving average with a sample rate of 100 milliseconds) Measured at Kilroot Power Station
Average df/dt Hz/Sec	This is the rate of change of frequency observed between two points in time. The first point being when the frequency passes through 49.8 Hz and the second when the frequency nadir is observed between t + 5 seconds and t + 15 seconds Measured at Kilroot Power Station

5.5.5 Historical Frequency Excursions

Figure 31: Historic Frequency Excursions 2012-2016

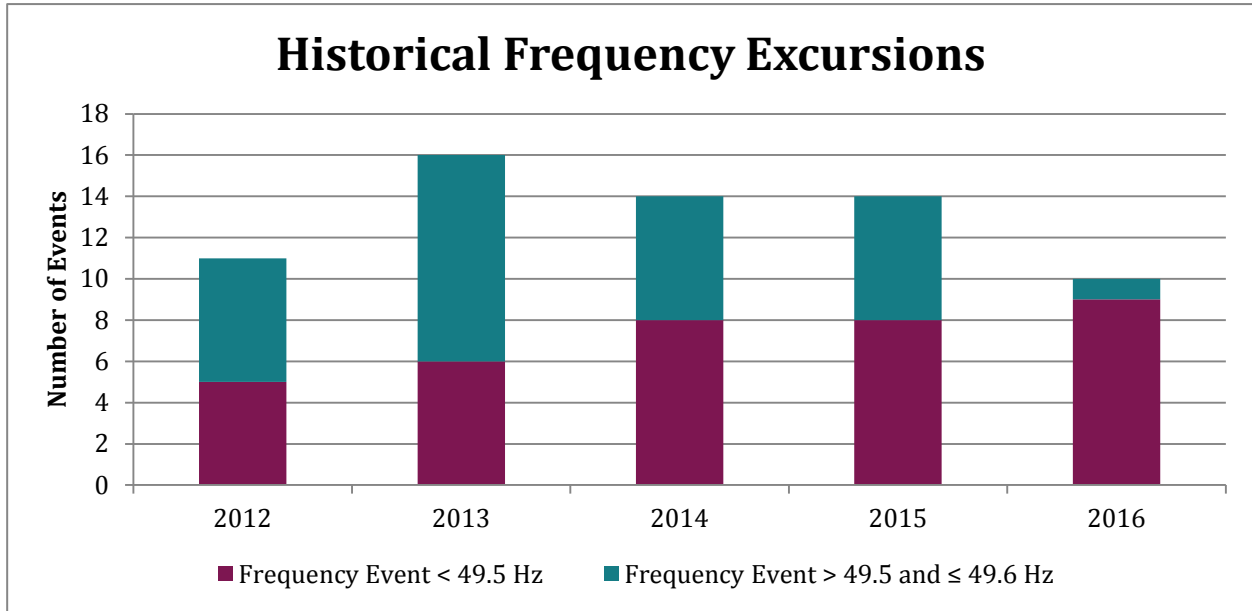

6. Appendix 1 Glossary

6.1 DCEF

Directional comparison earth fault. A teleprotection scheme that allows accelerated tripping by exchanging permit and receive signals for earth faults in a relay's forward direction.

6.2 Disturbance

A system disturbance is defined as one or more related faults and their consequences which occur either simultaneously or over a period of time. These incidents are grouped in a single system disturbance report under the highest voltage involved.

6.3 Fault

Any abnormal event causing or requiring the tripping of a Main System circuit breaker automatically within the Main System. Any abnormal event causing or requiring the closing of a Main System circuit breaker automatically within the Main System. Any abnormal event causing or requiring the tripping of an MV circuit breaker automatically by under frequency relay operation.

6.4 Main system: EirGrid

The main transmission system includes: the 400 kV, 220 kV and 110 kV overhead line (OHL) and underground cable (UGC) network, the 400 kV, 220 kV and 110 kV busbars and couplers, the 400/220 kV and 220/110 kV coupling transformers (with the exception of those feeding the Dublin city 110 kV network). It also includes the 275 kV ESB/NIE Networks interconnector as far as the border with Northern Ireland, and the associated 275/220 kV transformers. The main transmission system does not include the Dublin city 110 kV network or the 220/110 kV coupling transformers at Carrickmines, Inchicore and Poolbeg. The HV circuit breakers of tail connected lines and directly connected transformers (DSO load, directly connected industrial customer load, generator and HVDC interconnector transformers) are part of the main transmission system thus faults on these lines and transformers, which cause transmission system circuit breakers to be tripped, are reported.

6.5 Main system: SONI

The main transmission system includes: the 275 kV and 110 kV OHL and UGC network, the 275 kV and 110 kV busbars and couplers, the 275/110 kV interbus transformers, and all 110/33 kV load transformers (aka main transformers). It also includes the 275 kV ESB/NIE Networks interconnector as far as the border with Ireland. The HV circuit breakers of directly connected transformers (generator and HVDC interconnector transformers) are part of the main transmission system thus faults on these transformers, which cause transmission system circuit breakers to be tripped, are reported.

6.6 Major incident

A major incident is one which results in the loss of greater than or equal to one System Minute for the entire incident.

6.7 MVA Minute Lost

Amount of Power (Mega Volt-Amp) not supplied during an interruption of one minute.

6.8 Non Main System/Outside the Main System

All HV plant on the Irish electricity network that does not form part of the Main System: The Dublin 110 kV network which is controlled by the DCC (the MV system in Ireland is controlled by the ESB SDCC in Wilton and the NDCC in Leopardstown), all DSO and Industrial Customer load transformers, all IPP generator transformers, and all plant on the NIE NETWORKS owned, SONI controlled, HV system in Northern Ireland.

6.9 Non main system/outside the main system: EirGrid

All HV plant on the Irish electricity network that does not form part of the main system: the Dublin 110 kV network (controlled by the DSO at the northern distribution control centre (NDCC). The MV system in Ireland is controlled by the SDCC in Wilton and the NDCC in Leopardstown), all DSO and industrial customer load transformers, all IPP generator transformers, and all plant on the NIE NETWORKS owned, SONI controlled, HV system in Northern Ireland.

6.10 Non main system/outside the main system: SONI

All HV plant connected to the Northern Irish electricity network that does not form part of the main system: all IPP generator transformers, HVDC interconnector transformers, and all plant on the ESB owned, EirGrid controlled, HV system in Ireland

6.11 Non System Fault

Any unplanned circuit breaker operation resulting from a cause other than a system fault or incorrect manual operation from a control point.

6.12 Permanent Fault

A fault is permanent if the component or unit is damaged and cannot be restored to service until repair or replacement is completed. An overhead line trips and stays out of service due to the absence or outage of reclosing facilities; the fault is permanent if maintenance staff have to carry out equipment repairs or replacement before the line is returned to service. A protection setting change is required on the piece of plant before or after it is switched in following a fault.

6.13 POTT

Permissive overreach transfer trip. A distance teleprotection scheme that allows accelerated tripping by exchanging permit and receive signals for faults in a relay's zone 2.

6.14 Protection - Correct Operation

The operation is correct if a fault is cleared by the protection (in any time step) such that the correct circuit breakers open and no other circuit breaker opens.

6.15 Protection - Incorrect Operation

The operation is incorrect if, while a fault is being cleared, a circuit breaker is opened which should not have opened or a circuit breaker remains closed which should have opened.

6.16 PUTT

Permissive underreach transfer trip. A distance teleprotection scheme that allows accelerated tripping by receiving a signal for a fault in a relay's forward direction.

6.17 STAR Scheme

Short Term Active Response is a scheme operated by EirGrid whereby large electricity consumers voluntarily contract to make their load available for short term interruptions. This service provides EirGrid with approximately 45 MW of static reserve that is utilised in the event of system frequency falling below 49.3 Hz.

6.18 Sustained Interruption

A sustained interruption is one which lasts for more than one minute.

6.19 System Fault

Any fault or system abnormality which involves, or is the result of failure of primary electrical apparatus and which requires the disconnection of the affected equipment from the system by the automatic tripping of the associated circuit breaker.

6.20 System Minute

A measure of the energy not supplied for a disturbance. The metric takes account of the load lost (MW), duration of disconnection (Minutes) and peak system demand (MW), to allow for historical comparison. For example, if 300 MW were lost for 10 minutes and the system peak was 3000 MW, this would represent one System Minute.

System Minutes = (Load MW x Duration mins) / (System Peak MW) = (300 x 10) / 3000 = 1

6.21 Transient Fault

A fault is transient if the unit or component is undamaged and is restored to service through manual switching operations, or rapid automatic reclosure on overhead lines, without repair being performed, but possibly with on-site inspection.

6.22 Zone Clearance Ratio

The Zone Clearance Ratio is defined as the ratio of the number of short circuit faults not cleared in Zone 1 to the total number of short circuit faults per year. The more faults cleared in Zone 1, the quicker they are taken off the power system which reduces the risk of system instability, plant damage and injury to personnel.

6.23 Zones of Protection

Figure 32: Zones of Protection

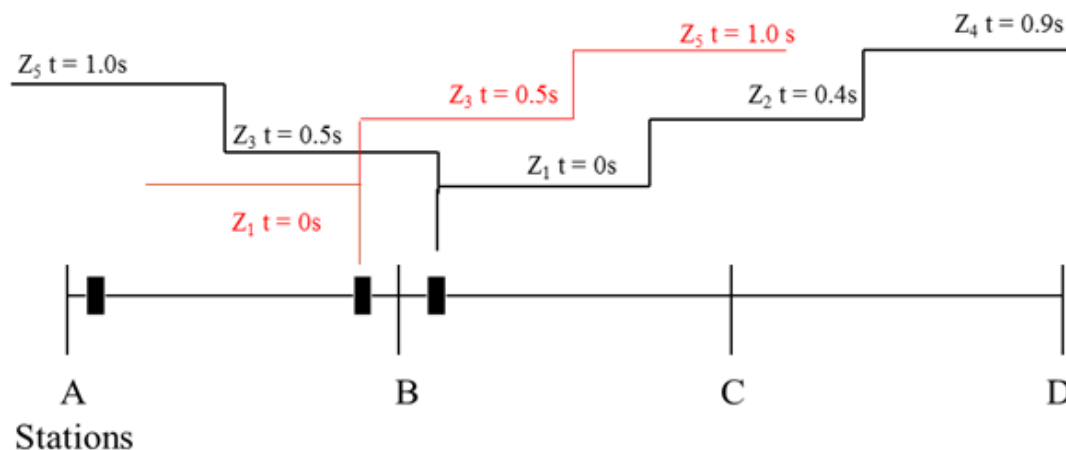

Zone 1 on an impedance (distance) relay is the primary protection zone and in the case of an overhead line is set to 70 - 85 % of the circuit length depending on the location of the circuit in the transmission network. There is no time delay for the relay to pick up when a fault occurs within the Zone 1 reach, as shown in [Error! Reference source not found.](#). Typical Zone 1 clearance times are 50 to 150 ms.

Zone 2 on an impedance relay is used as a backup protection zone and is set to 100 % of the circuit length plus 20 - 50 % of the length of the shortest feeder at the remote end of the protected circuit. A delay of approximately 400 ms is applied in Zone 2 settings and so typical Zone 2 fault clearance times are 450 to 550 ms.

Zone 3 on an impedance relay is used as a backup protection zone and is set to 20 - 50 % of the length of the shortest feeder in the reverse direction. A delay of approximately 500 ms is applied in Zone 3 settings and so typical Zone 3 fault clearance times are 550 to 650 ms.

Zone 4 is the third forward step of a distance scheme with a time delay of approximately 900 ms.

Zone 5 is the second reverse step of a distance protection scheme with a time delay of approximately 1.1 seconds.

7. Appendix 2 All Island Frequency Excursion Graphs

Cause of Incident	Date
Great Island 4	09/04/2016
Aghada Unit 2	12/04/2016
Whitegate	24/04/2016
Great Island 4	20/05/2016
Great Island 4	31/05/2016
Aghada Unit 2	05/06/2016
Aghada Unit 2	09/06/2016
Huntstown Unit 2	17/07/2016
Great Island 4	03/09/2016
Huntstown Unit 2	11/09/2016

7.1 Great Island 4 – 09/04/2016

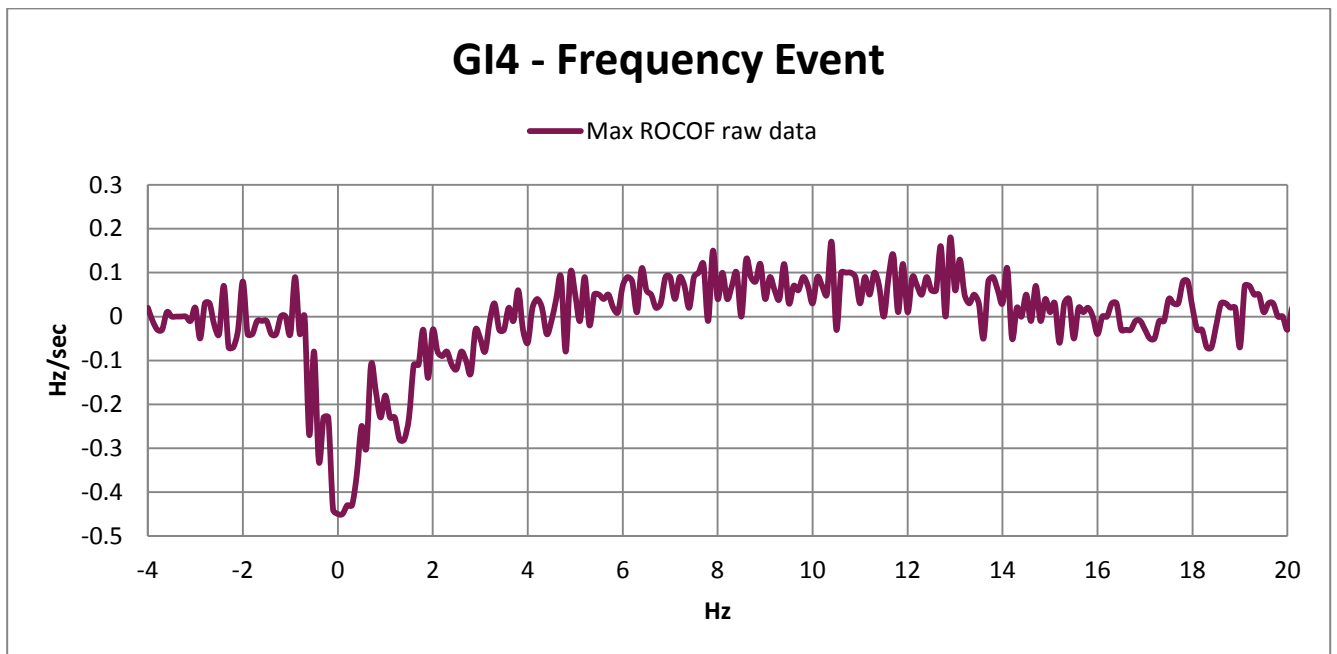
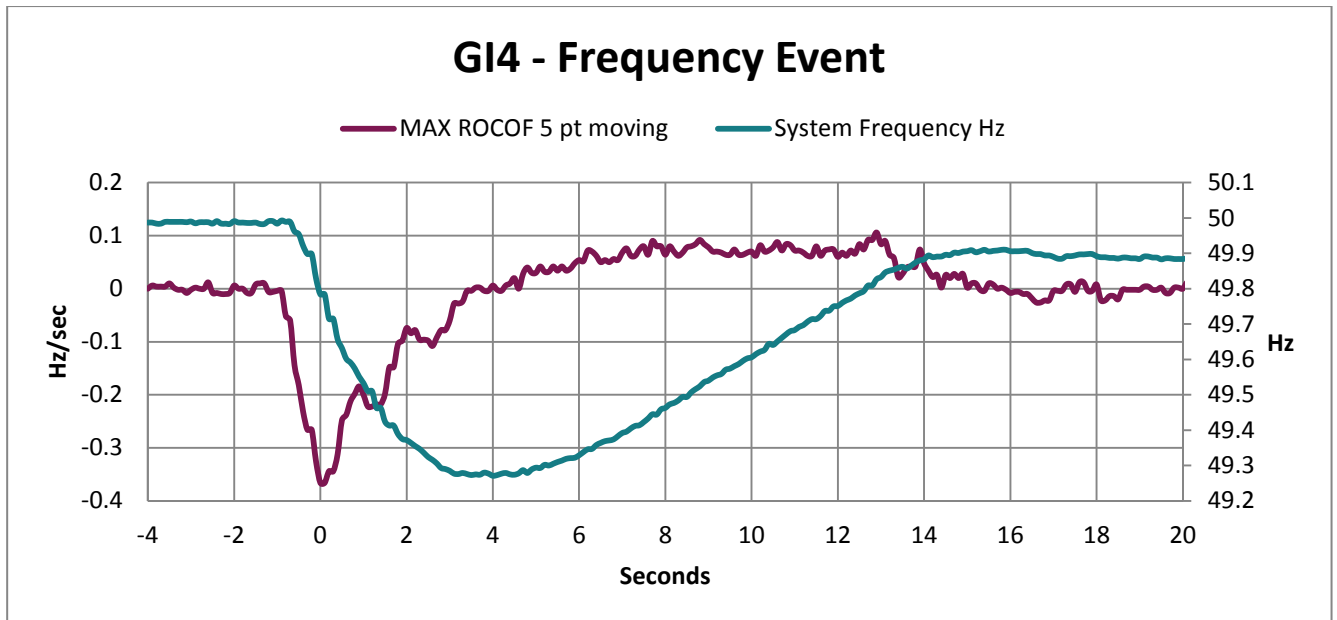

7.2 Aghada Unit 2 – 09/04/2016

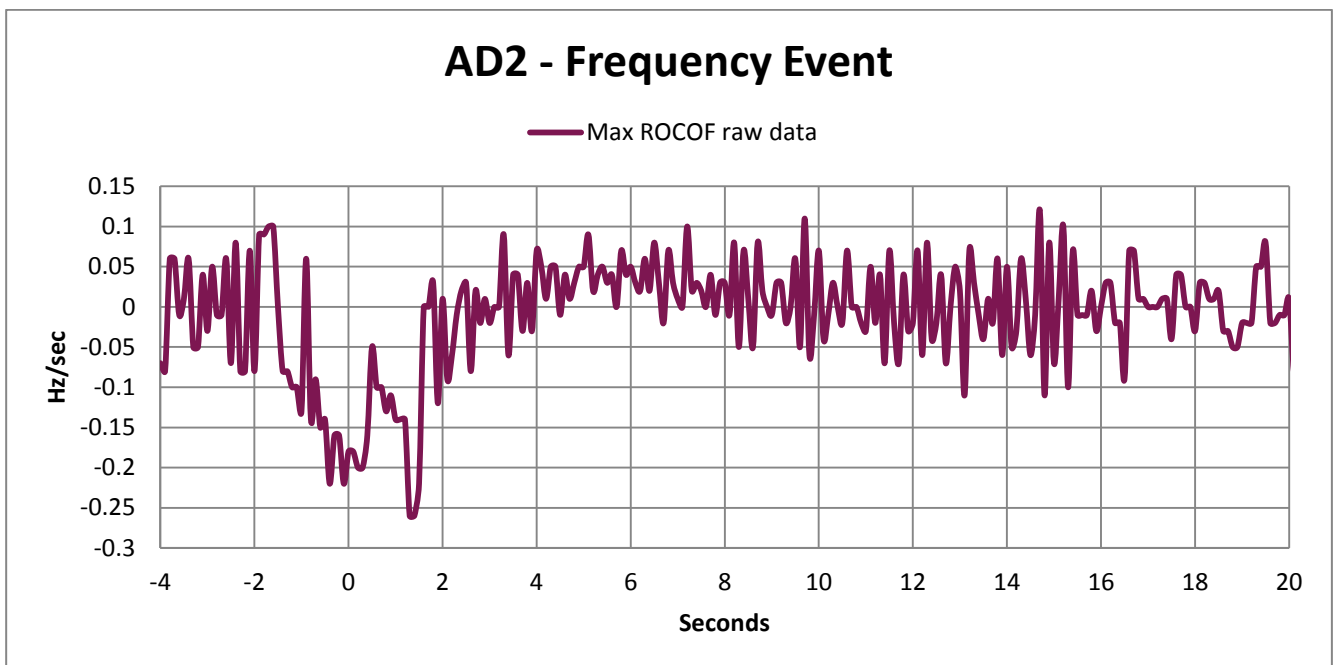
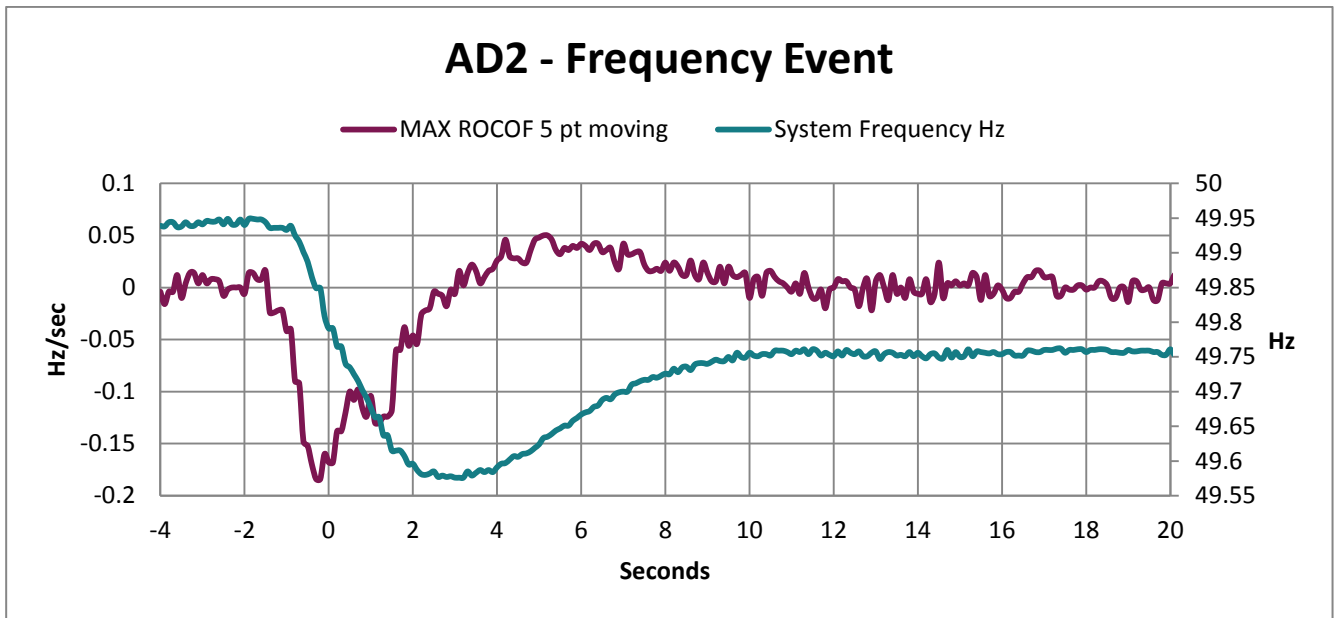

7.3 Whitegate – 24/04/2016

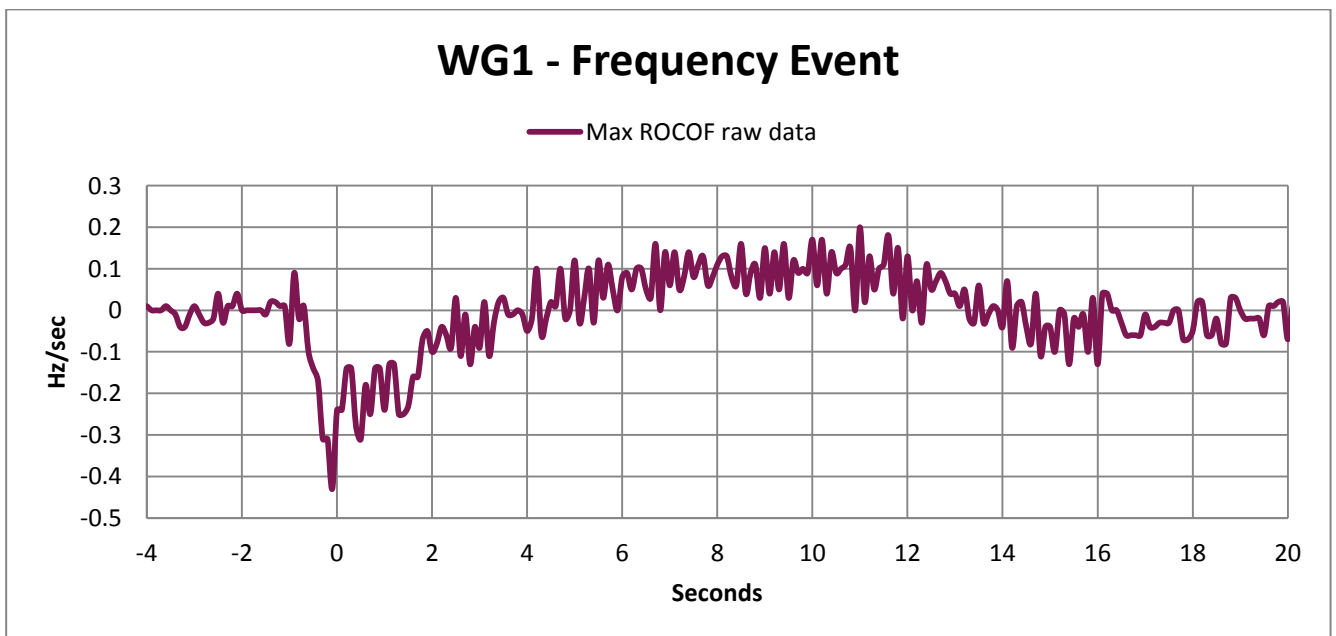
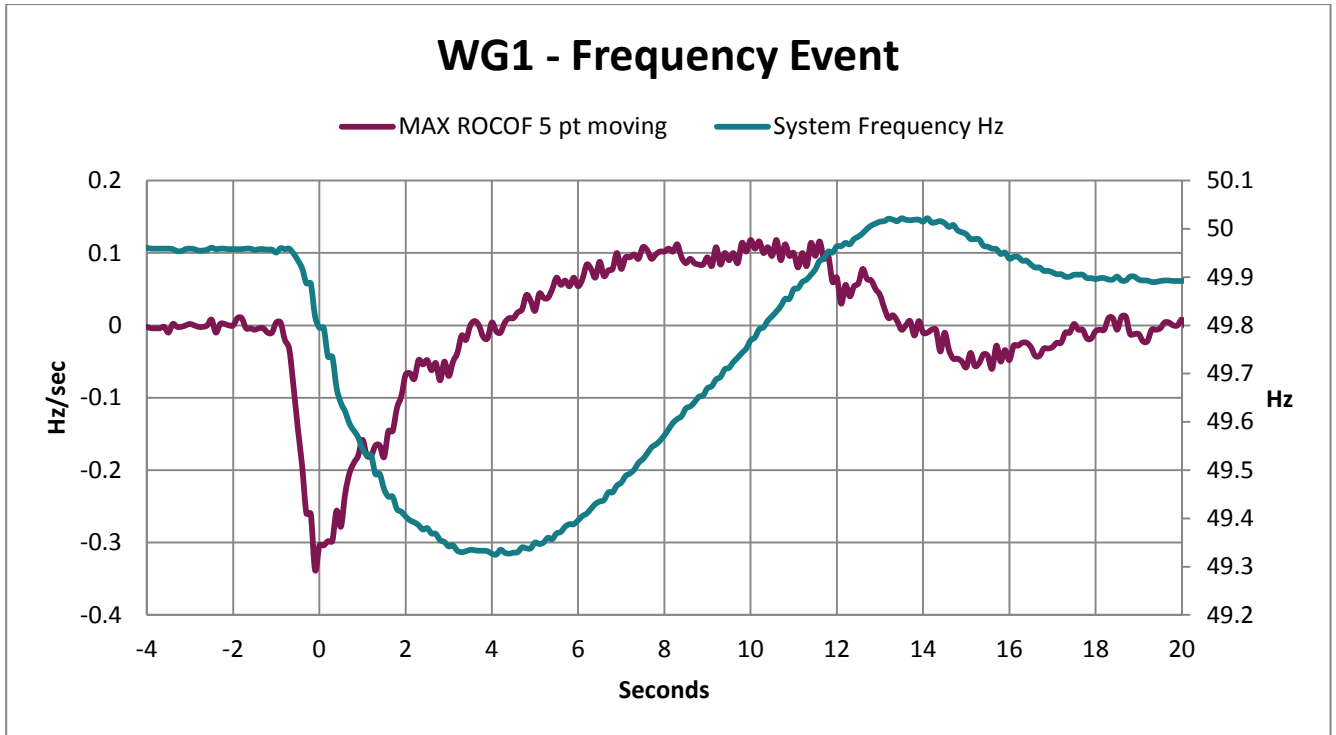

7.4 Great Island 4 – 20/05/2016

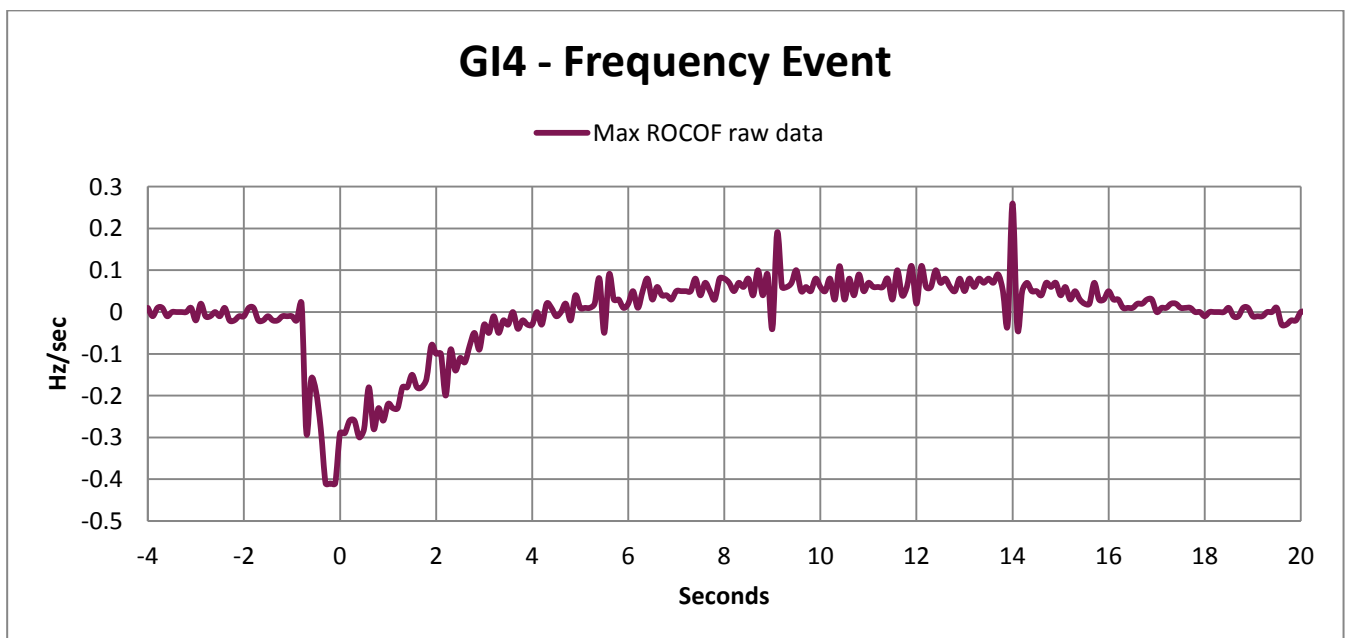
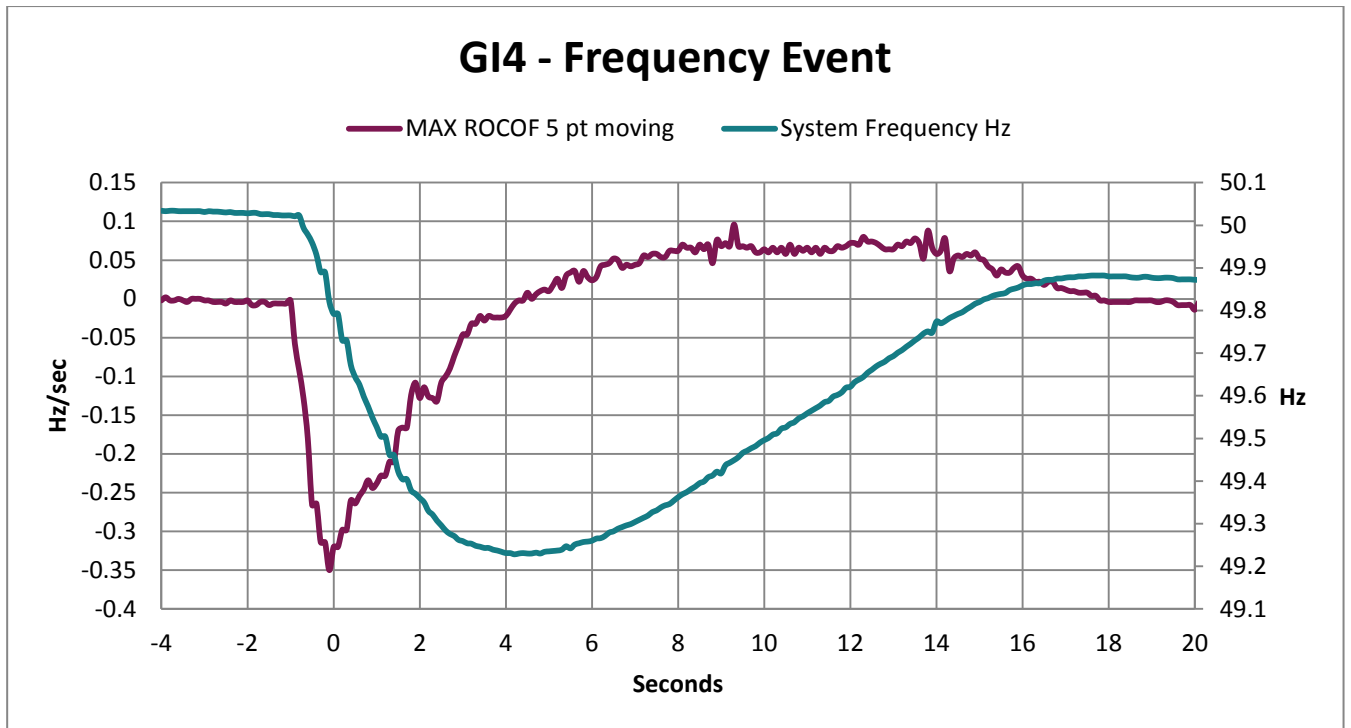

7.5 Great Island 4 – 31/05/2016

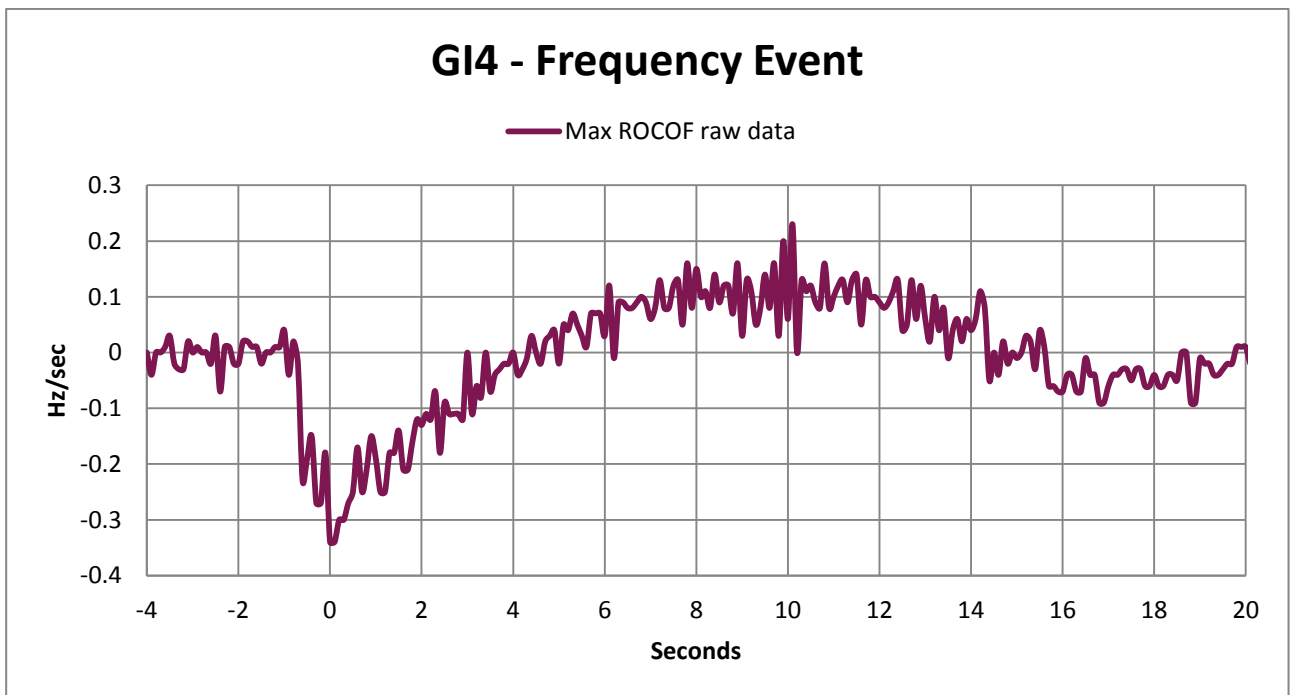
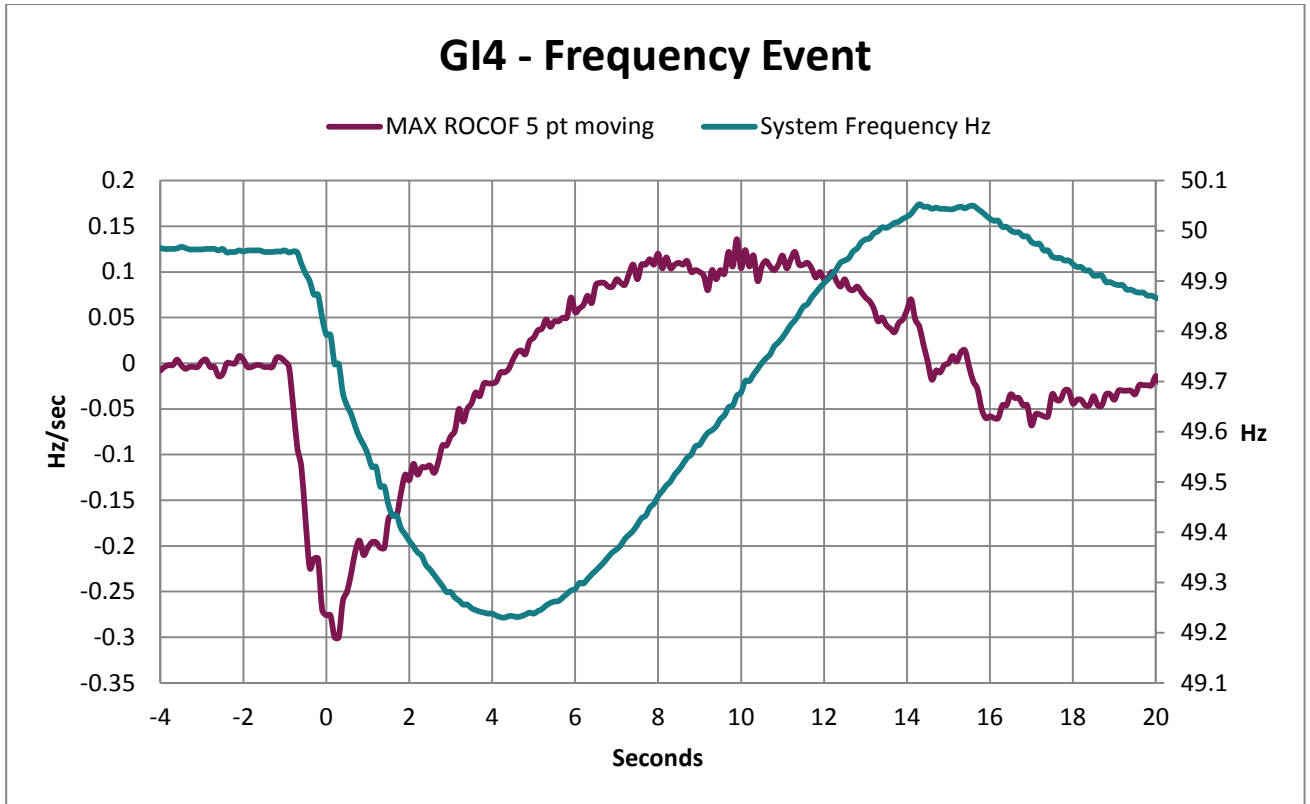

7.6 Aghada Unit 2 – 05/06/2016

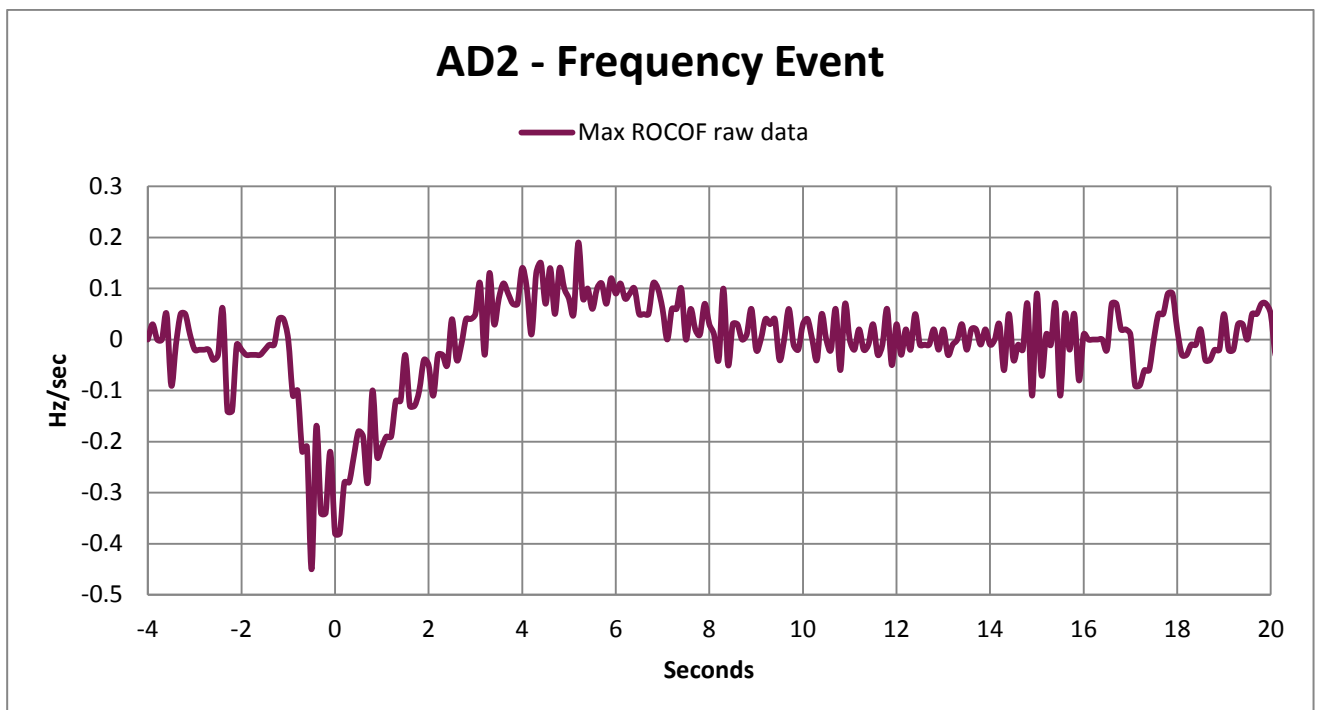
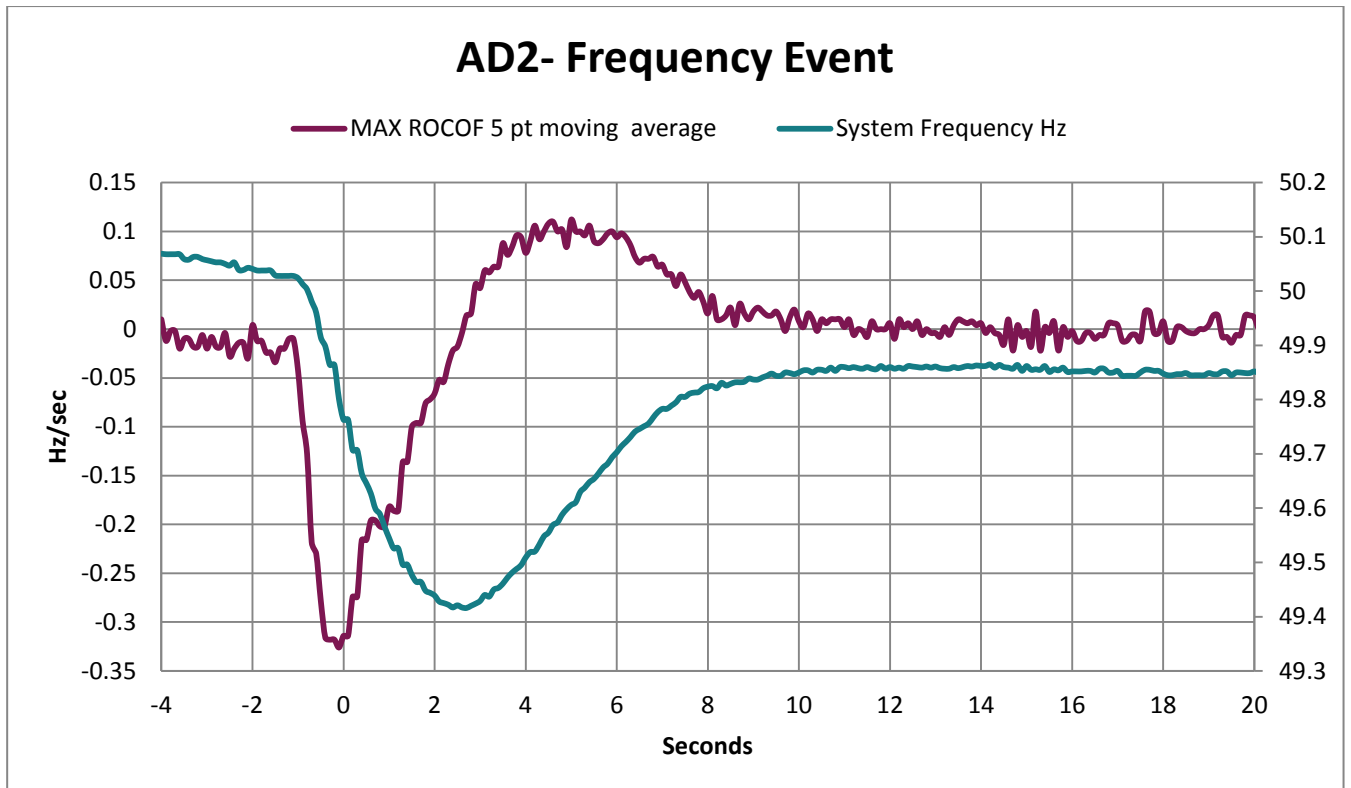

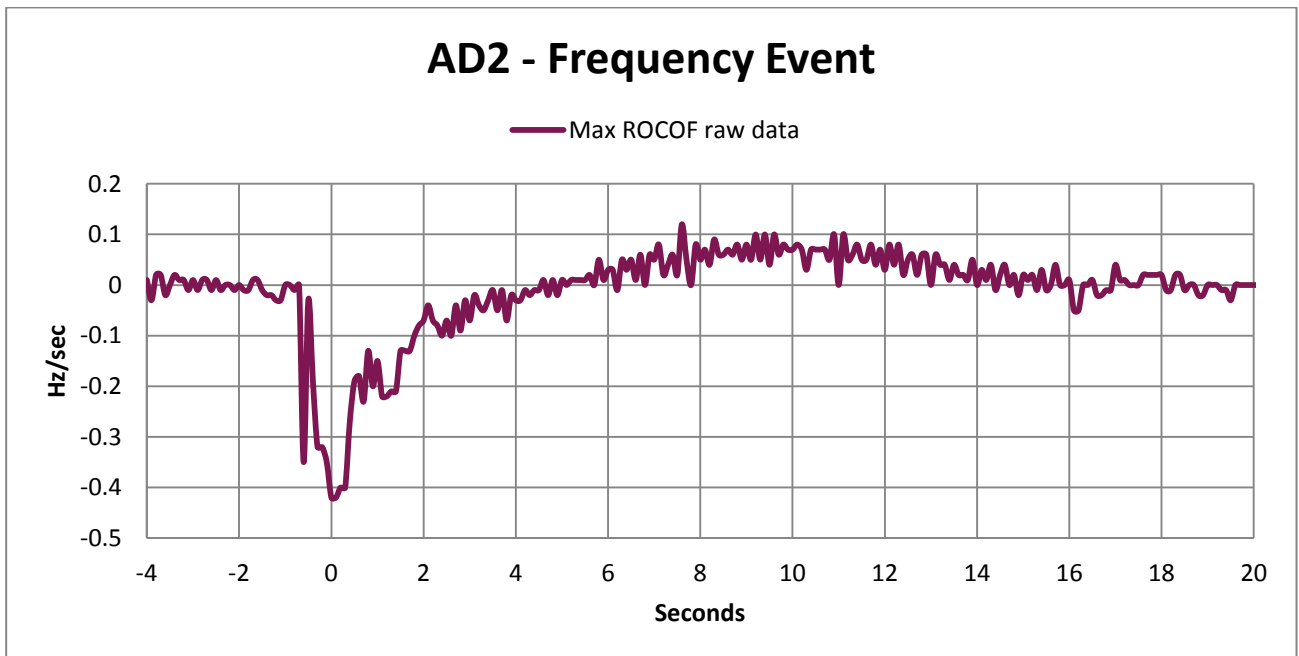
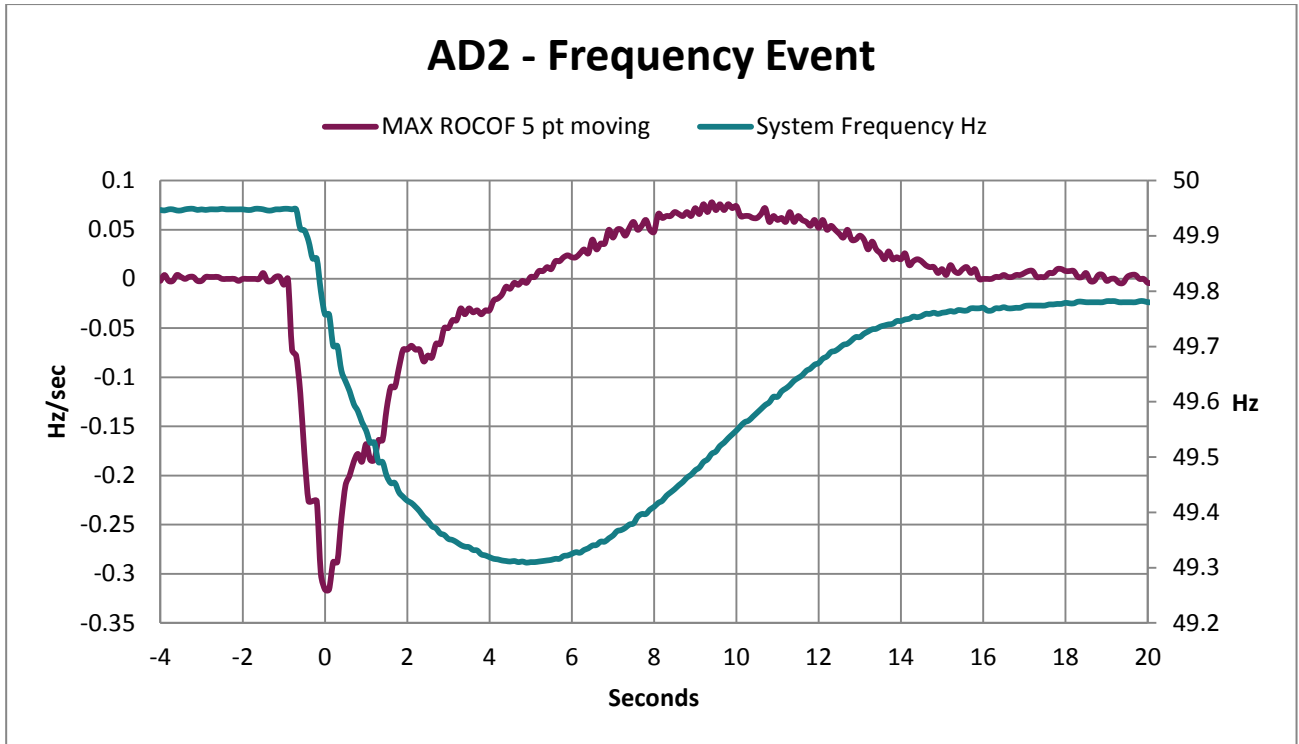

7.8 Huntstown Unit 2 – 17/07/2016

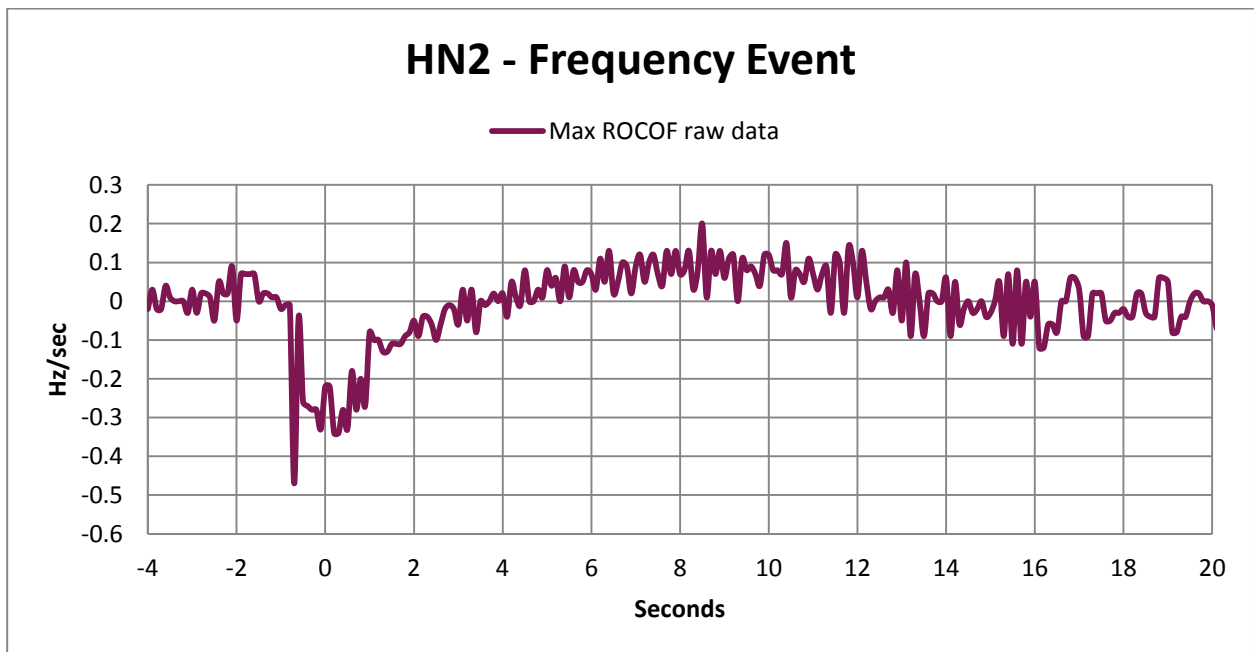
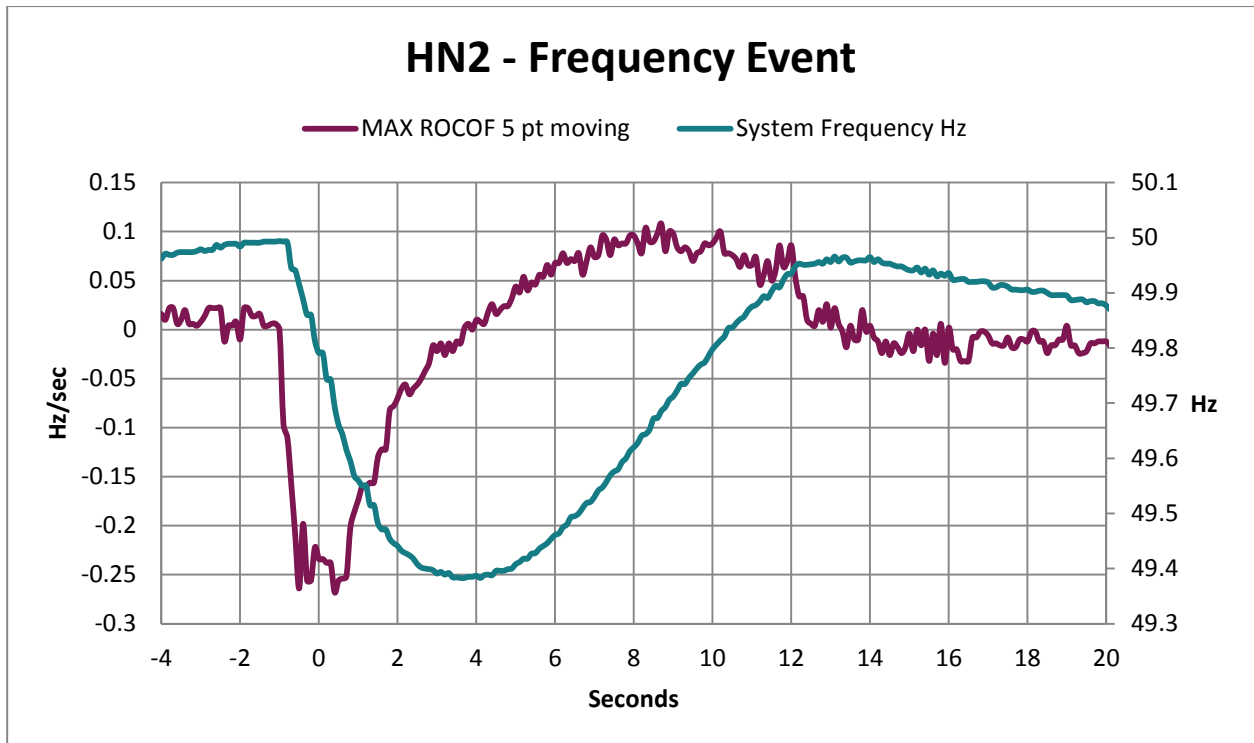

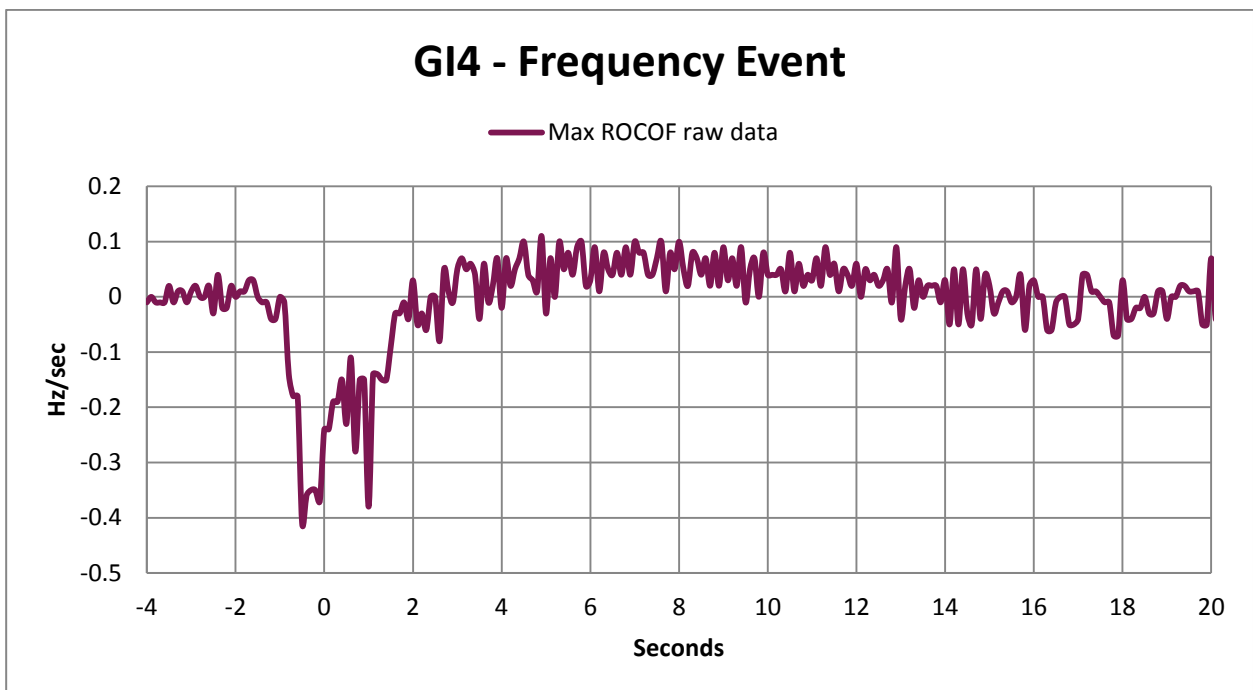
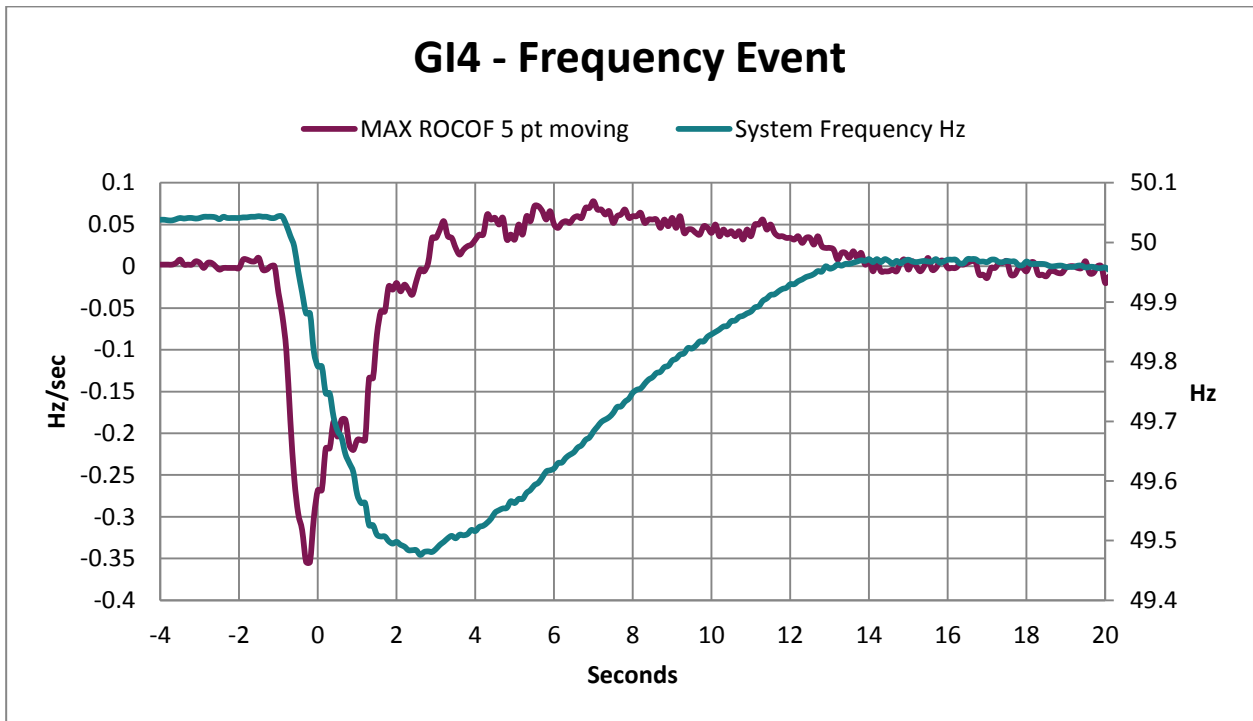

7.10 Huntstown Unit 2 – 11/09/2016

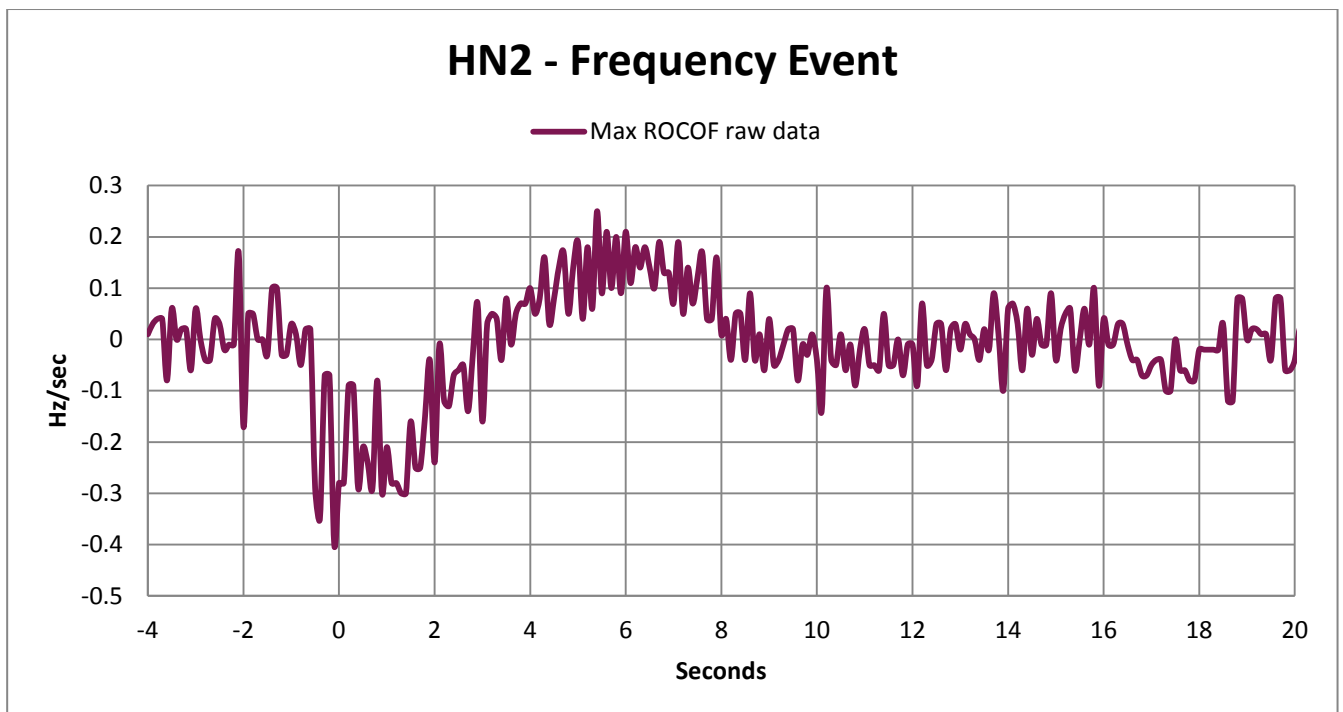
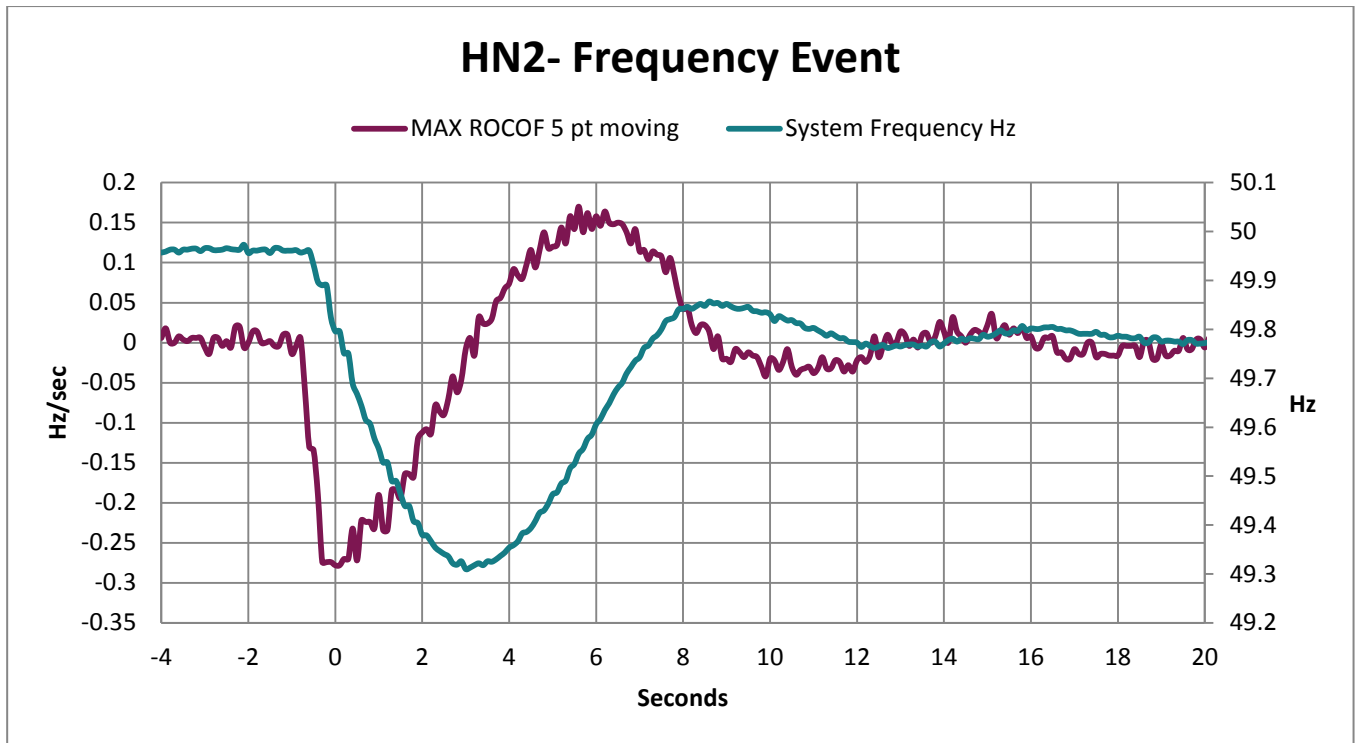

8. Appendix 3 All Island Fully Dispatchable Generation Plant

Company	Unit	Capacity (MW)	Fuel	365-day Rolling Availability %
Activation Energy	AEDSU - AE1	89	DSU	42.65
	AEDSU - AE2	11	DSU	71.68
	AEDSU - AE3	14	DSU	85.59
	AEDSU - AE4	11	DSU	66.67
	AEDSU - AE5	15	DSU	19.90
Activation Energy Ltd (NI)	AE_DSU_NI - AEA	9	DSU	75.44
AC Automation	AC - ACA	6	DSU	-
AES	Ballylumford - B10	94	Gas / Distillate Oil	66.32
	Ballylumford - B21	249	Gas / Distillate Oil	91.74
	Ballylumford - B22	249	Gas / Distillate Oil	90.41
	Ballylumford - BGT1	58	Distillate	95.58
	Ballylumford - BGT2	58	Distillate	94.96
	Ballylumford - BPS4	144	Gas / Distillate Oil	96.90
	Ballylumford - BPS5	147	Gas / Distillate Oil	98.11
	Kilroot - KGT1	29	Distillate	97.20
	Kilroot - KGT2	29	Distillate	96.96
	Kilroot - KGT3	42	Distillate	86.94
	Kilroot - KGT4	42	Distillate	96.63
	Kilroot - KPS1	238	Coal / Heavy Fuel Oil	95.45
	Kilroot - KPS2	238	Coal / Heavy Fuel Oil	80.45
Aughinish Alumina Ltd	Seal Rock - SK3	85	Gas / Distillate Oil	89.47
	Seal Rock - SK4	85	Gas / Distillate Oil	85.14
Bord Gáis	Whitegate - WG1	444	Gas / Distillate Oil	90.82
Contour Global	Contour - CGA	12	Gas	99.25
Coolkeeragh ESB	Coolkeeragh - C30	408	Gas / Distillate Oil	81.60
	Coolkeeragh - CG8	53	Distillate	94.51
DAE Virtual Power Plant	DAE VPP - DP1	29	DSU	46.20
	DAE VPP - DP2	10	DSU	7.61
Edenderry Power Ltd	Edenderry - ED1	118	Peat	86.27
	Edenderry - ED3	58	Gas / Distillate Oil	99.73
	Edenderry - ED5	58	Gas / Distillate Oil	99.82
Electricity Exchange Limited	Elect Exchng - EE1	20	DSU	60.34
	Elect Exchng - EE2	18	DSU	34.96
Electric Ireland DSU	Electric Irl - EI1	20	DSU	80.51
Empower	EmpowerAGU - EMP	3	Distillate	98.04

Company	Unit	Capacity (MW)	Fuel	365-day Rolling Availability %
Endeco Limited Ltd.	Endeco T Ltd - EC1	37	DSU	70.51
	Endeco T Ltd - EC2	2	DSU	31.85
	Endeco T Ltd - ECA	1	DSU	-
Endesa	Great Island - GI4	461	Gas / Distillate Oil	84.90
	Rhode - RP1	52	Distillate	97.40
	Rhode - RP2	52	Distillate	99.07
	Tarbert - TB1	54	Heavy Fuel Oil	98.04
	Tarbert - TB2	54	Heavy Fuel Oil	98.75
	Tarbert - TB3	241	Heavy Fuel Oil	99.17
	Tarbert - TB4	243	Heavy Fuel Oil	94.93
	Tawnaghmore - TP1	52	Distillate	66.07
	Tawnaghmore - TP3	52	Distillate	59.71
Energy Trading Ireland	Ener Trd Irl - ET1	11	DSU	86.70
	Ener Trd NI - ETR	18	DSU	-
Evermore Renewable Energy	Lisahally - LPS	17.6	Biomass	72.77
Indaver	Indaver - IW1	17	Waste to Energy	87.63
iPower	iPower AGU - AGU	74	Distillate	96.02
Powerhouse Generation Ltd. (NI)	PHG - PH1	20	DSU	58.74
	PHG - PH2	6	DSU	-
Powerhouse Generation Ltd.	Powerhouse G - PG1	7.011	DSU	82.87
Synergen	Dublin Bay - DB1	405	Gas / Distillate Oil	80.72
Tynagh Energy Ltd	Tynagh - TYC	384	Gas / Distillate Oil	94.07
Viridian Power and Energy	Huntstown - HN2	400	Gas / Distillate Oil	87.04
	Huntstown - HNC	342	Gas / Distillate Oil	85.68
	Viridian DSU - VE1	26	DSU	53.97

Company	Unit	Capacity (MW)	Fuel	365-day Rolling Availability %
ESB Power Generation	Aghada - AD1	258	Gas / Distillate Oil	94.19
	Aghada - AD2	431	Gas / Distillate Oil	97.16
	Aghada - AT11	90	Gas / Distillate Oil	98.37
	Aghada - AT12	90	Gas / Distillate Oil	98.43
	Aghada - AT14	90	Gas / Distillate Oil	97.30
	Ardnacrusha - AA1	21	Hydro	75.23
	Ardnacrusha - AA2	22	Hydro	76.38
	Ardnacrusha - AA3	19	Hydro	74.50
	Ardnacrusha - AA4	24	Hydro	63.59
	Erne - ER1	10	Hydro	75.76
	Erne - ER2	10	Hydro	91.51
	Erne - ER3	22	Hydro	93.25
	Erne - ER4	22	Hydro	96.99
	Lee - LE1	15	Hydro	23.42
	Lee - LE2	4	Hydro	25.25
	Lee - LE3	8	Hydro	94.50
	Liffey - LI1	15	Hydro	77.79
	Liffey - LI2	15	Hydro	80.10
	Liffey - LI4	4	Hydro	21.65
	Liffey - LI5	4	Hydro	93.31
	Lough Ree - LR4	91	Peat	88.79
	Marina - MRC	95	Gas / Distillate Oil	98.31
	Moneypoint - MP1	285	Coal / Heavy Fuel Oil	82.48
	Moneypoint - MP2	285	Coal / Heavy Fuel Oil	88.46
	Moneypoint - MP3	285	Coal / Heavy Fuel Oil	90.92
	North Wall - NW5	104	Gas / Distillate Oil	95.81
	Poolbeg - PBA	232	Gas / Distillate Oil	95.52
	Poolbeg - PBB	232	Gas / Distillate Oil	86.93
	Turlough H - TH1	73	Hydro - Pumped Storage	94.28
	Turlough H - TH2	73	Hydro - Pumped Storage	88.56
	Turlough H - TH3	73	Hydro - Pumped Storage	96.19
	Turlough H - TH4	73	Hydro - Pumped Storage	95.90
	West Offaly - WO4	137	Peat	85.21

9. Appendix 4 EirGrid Maintenance Policy Terms

The following summarises the main terms and activities in the asset maintenance policy as operated by EirGrid⁷. The need to ensure that equipment continues to operate in a safe, secure, economic and reliable manner, while minimising life cycle costs, underlies the principles behind this asset maintenance policy. Effective maintenance management balances the costs of repair, replacement and refurbishment against the consequences of asset failure.

There are four primary maintenance categories:

1. **Preventative/Routine:** Preventive/routine maintenance is planned at predetermined intervals to reduce the likelihood of equipment degradation which could lead to plant failure e.g. condition assessment. This type of maintenance is planned in advance and the frequencies of these activities are pre-determined by the EirGrid Asset Maintenance Policy
2. **Corrective:** Corrective maintenance may consist of repair, restoration or replacement of equipment before functional failure. Corrective maintenance requirements are identified through regular inspections. The aim of routine inspections is to identify the potential for failure in time for the solution to be planned and scheduled and then performed during the next available outage.
3. **Fault:** Fault maintenance includes activities arising from unexpected equipment failure in service.
4. **Statutory Maintenance:** Maintenance which is carried out to facilitate statutory requirements e.g. Pressure Vessel Inspections, bund inspections.

⁷ In Northern Ireland maintenance policy for the transmission system is the responsibility of NIE NETWORKS as licenced Transmission Owner.

Please refer to the ‘Guide to Transmission Equipment Maintenance’ which is published on the EirGrid website for further information⁸.

⁸ http://www.eirgridgroup.com/site-files/library/EirGrid/Guide-to-Transmission-Equipment-Maintenance_V3_published.pdf

10. Appendix 5 Formulae (EirGrid Transmission System)

10.1 Availability & Unavailability Formula

Equation 2: Availability of 110kV, 220 kV, 275 kV and 400 kV lines

$$\text{System Availability} = 1 - \frac{\sum_{i=1}^n \text{Duration of Outage (i)} * \text{Length of Line (i)}}{\sum_{j=1}^m \text{Length of Line (j)} * \text{Days in a Year}}$$

Where n = The total number of lines (at that voltage level) for which outages occurred

m = The total number of lines at that voltage level

Equation 3: Availability of 220 kV/110 kV, 275 kV/220 kV and 400 kV/220 kV transformers

$$\text{System Availability} = 1 - \frac{\sum_{i=1}^n \text{Duration of Outage (i)} * \text{MVA of Transformer (i)}}{\sum_{j=1}^m \text{MVA of Transformer (j)} * \text{Days in a Year}}$$

Where: n = The total number of transformers (at that voltage level) for which outages occurred

m = The total number of transformers at that voltage level

Equation 4: System Unavailability

$$\text{System Unavailability} = 1 - \frac{\sum \text{Hours each Circuit is Available}}{\text{Number of Circuits} * \text{Hours in Period}}$$

Equation 4 is the same as that used by Ofgem (The Office of Gas and Electricity Markets) in the UK.

10.2 System Minute Formula

Equation 5: System Minute Formula

$$\text{System Minutes} = \frac{\text{Energy not supplied MW Minutes}}{\text{Power at System Peak}}$$

Equation 6: System Minute Formula

$$\text{System Minutes} = \frac{(\text{MVA Minutes}) * (\text{Power Factor})}{\text{System Peak to Date}}$$

Where: Power factor = 0.9