



NEWTON COURT SUSTAINABLE ENERGY COMMUNITY
NC-SEC
“CASE STUDY” ON SOLAR PV

NEWTON COURT, GRANGE, DOUGLAS

Write a description for your map.

Legend

- CB to Clonability
- Newton Ct

74
HOUSES

BUILT IN 1975

Google Earth

Image Landsat / Copernicus



60 m

LEARN – PLAN – DO



• **DO** -WE MUST ANSWER 3 QUESTIONS

1. **IS THERE AN INTEREST IN THE COMMUNITY FOR A SOLAR PV SCHEME? -THE CASE OF NEWTON COURT**
2. **WHAT IS NEEDED FOR A SOLAR PV SCHEME?**
BASIC SYSTEM - PANELS – INVERTER – CABLES / SWITCHES
3. **WHO WILL DO THE WORK ?**
AN APPROVED SOLAR PV INSTALLER (SEAI REGISTERED)

Proposal to Newton Court Residents



**Research and analysis
indicated that a simple
Solar System would
cost in the region of**

€2,000 + €2,100 Grant=€4,100

Expression of Interest Form

Name (print all):

Address:

Eircode:

Phone:

Email:

House type: Terrace _____ Semi-Detached _____ Detached _____

Roof orientation:

South facing: ___ East/West: ___ East only: ___ West only: ___ Other ___

ESB MPRN Number:

Name of your electricity provider:

Contact person for Solar PV Installation:

Mobile of contact person:

The means of financing the Solar PV Scheme will be **own financing** or **loan financing** from....., at an interest rate of not more than % over five years with a payback at any time clause over the 5-year period.

RESULTS
21 Newton Court
4 others from outside of
Newton Court = 25 in total



**Tender 1
Supplies**

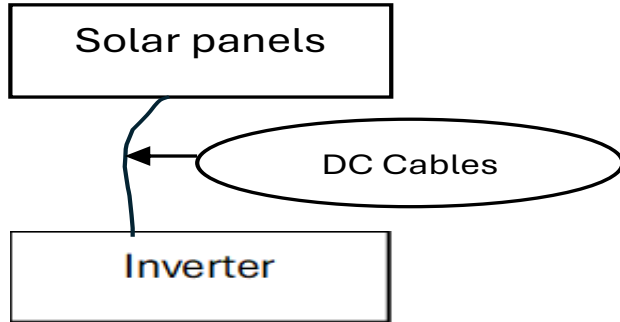

- Solar Panel include tie hooks and support frame.
- DC cables is the cabling from panels to inverter, which is usually located in the attic.

**Tender 2
Shipping / Transport**

Ideally 20ft container from China to Cork has the capacity for 25 houses.

Transport from Cork port to Installer's warehouse

Local Shipping and Transport Company with an Agent in China.

**Tender 3
Installation of Solar PV system to include AC cabling from inverter to distribution board and safety cut-off to include cabling (Fireman's Shunt).**

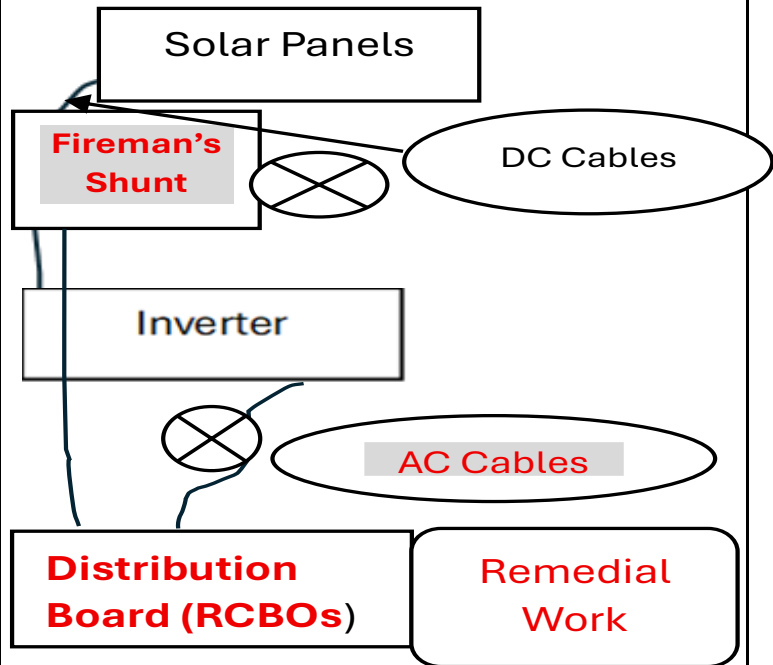

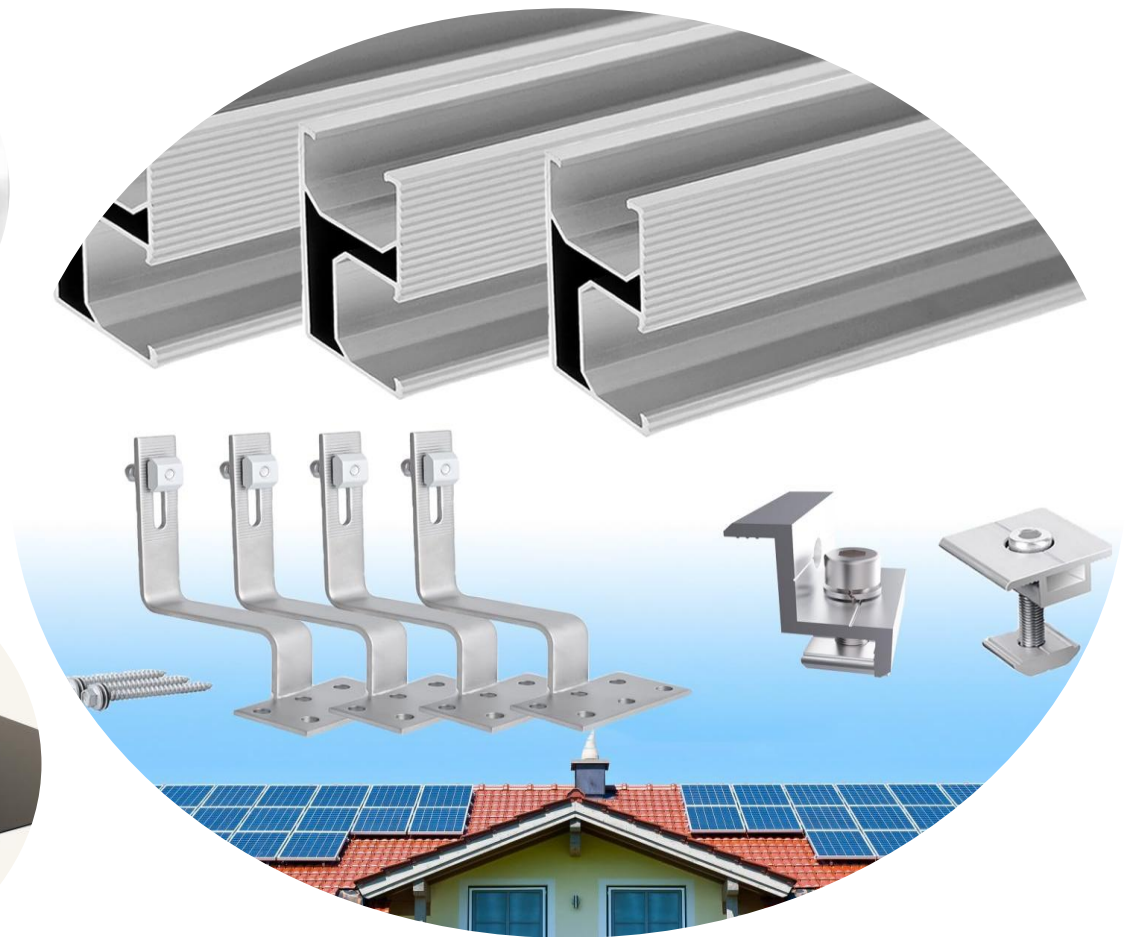
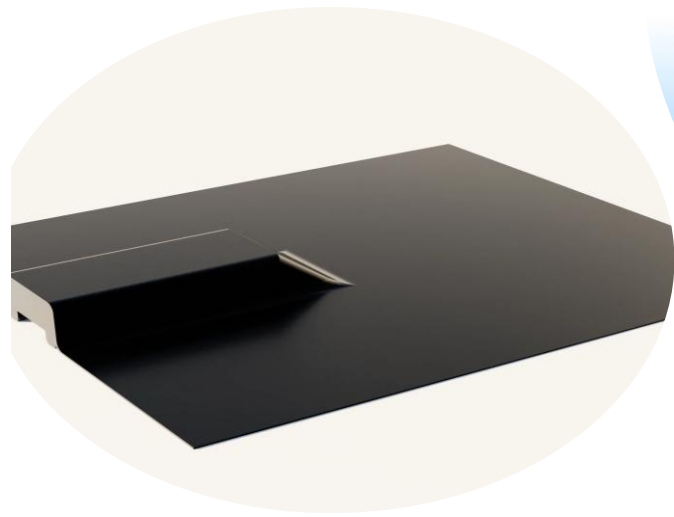



MC4 CONNECTORS





String Inverter Pros

- **Simplicity:** A single inverter for all panels allows for an easy installation
- **Affordability:** The least expensive option for a solar inverter.
- **System Monitoring:** Provides in-depth monitoring of the solar array.
- **Grid-Connection:** Grid-connected solar system

Hybrid Inverter

a "two-in-one" device that combines a **solar inverter and a battery charger**, managing power flow between solar panels, battery storage, the grid, and your home.

String Inverter Cons

- **Battery Incompatible:** Cannot be used in conjunction with a solar battery.

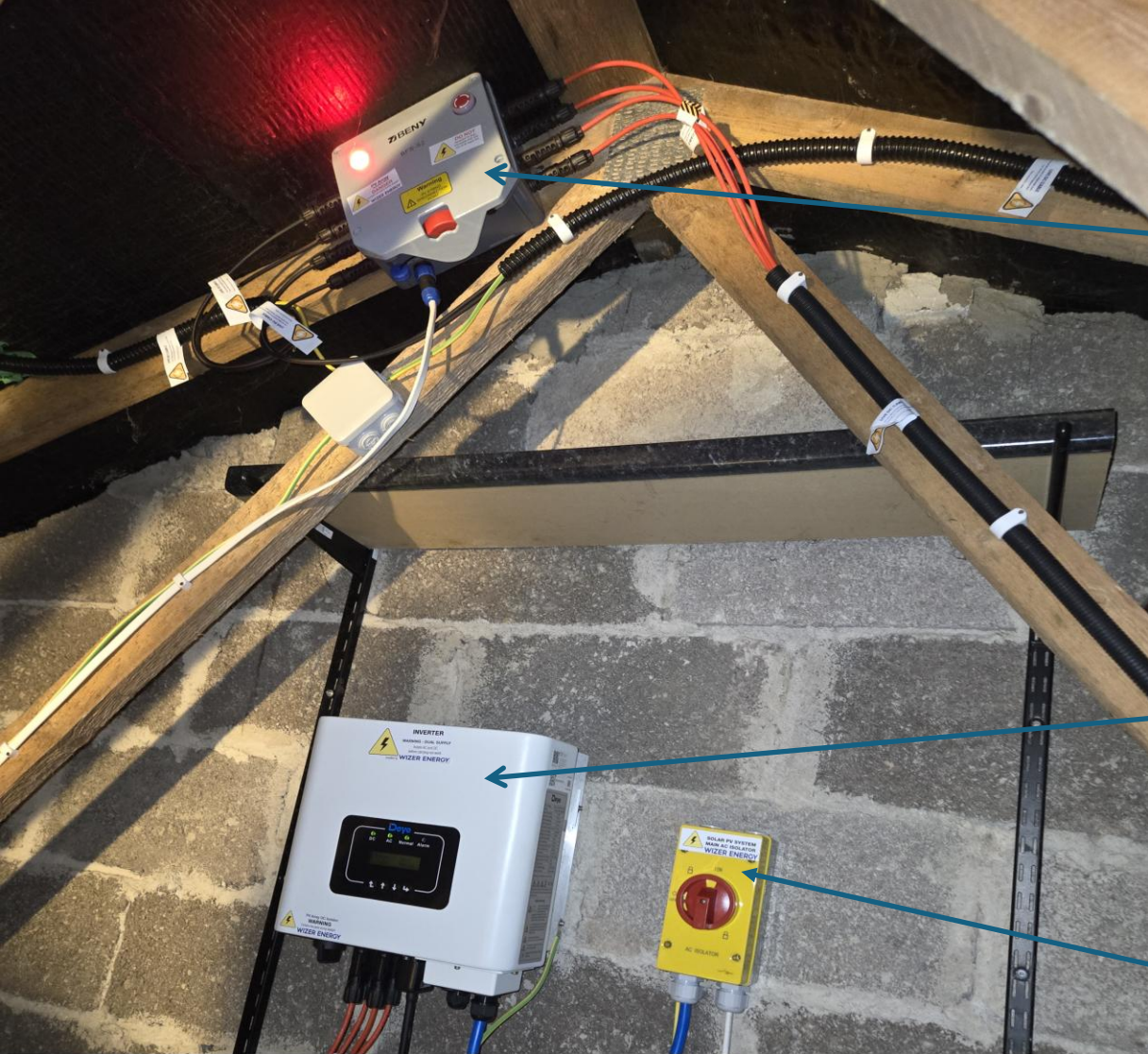

Fireman's Shunt

Inverter

AC Isolation Switch

Supplies

- **Zeoluff China**

www.zeoluff.com

TEDERING FOR SHIPPING AND INSTALLATION

Local Companies – Solar Installers Registered with SEAI

- Awarded contract to **Wizer Energy on partnership basis**

Local Shipping Companies with Agent in China

- **Cork Shipping and Transport with an Agent in Yantian Port, Shenzhen, China**

COLLECTION OF FUNDS AND SOURCES OF FINANCING

• Own Financing

- € 2100 for 8 panels @585w
- € 1900 for 6 panels @585w

- $10 \times 1900 = 19000$
- $15 \times 2100 = 31500$
- **Total =€50,500**

• Loan Financing

Elevate Credit Union (Douglas) provided loan funding to households at 5% over 5 years with a pay back clause to repay all the loan at any time over the 5 years.

Or loan from Elevate CU 1900@5% for 5 years = €35.86 per Month. Or 2100 @5% = €39.63 per Month over 5 years per Month

Supplies from China





NEWTON COURT SEC **(SUSTAINABLE ENERGY COMMUNITY)**

- **SOLAR PV** FOR 21 HOUSES IN THE ESTATE (PHASE 1)
- **80,000 kWh** OF ENERGY PER ANNUM
- **In total, 20 to 25 thousand Euros** IN ENERGY SAVING PER ANNUM

In partnership with

Wizer Energy Ltd, Little Island, Cork
www.wizerenergy.ie

Zeoluff, China
www.Zeoluff.com

Supported by

SEAI Sustainable Energy Authority of Ireland
www.SEAi.ie

Elevate Credit Union
www.elevatecu.ie

WIZER ENERGY
www.wizerenergy.ie



JUNE 2025



NEWTON COURT SEC
(NUGHAILE BUNNÓG KATHARÓID)

- TOSAD FÉICÉIL IN-ÉILEADAITH (PÓBLAIC)
- 03 900 828282
- 100% DÍ DALTA

In partnership with
State Energy and Water Control
and Planning
Unit
www.seai.ie



seai

Energise your Community

...cted co...
...y a sur...

visit seai.ie



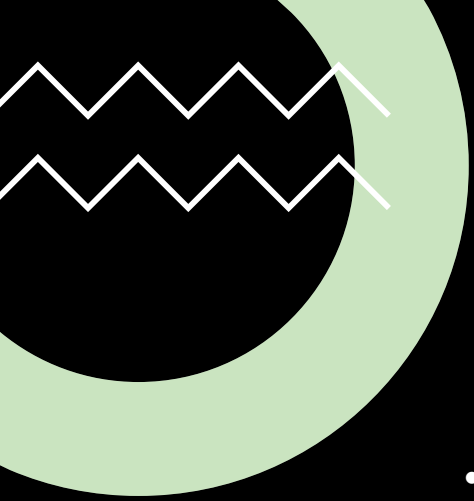

- **NC SEC**
- **Phase 1**

- **Newton Court**



PV OUTPUT 1 kWp (1000w)		Oliver's	Oliver's	Oliver's
	kWp	4.68kWp	4.68kWh	%
Month		Planned	Actual	Diference
Jan	36.6	171.29	0.00	0.00
Feb	49.9	233.53	0.00	0.00
Mar	78.4	366.91	0.00	0.00
Apr	103.1	482.51	0.00	0.00
May	117.4	549.43	0.00	0.00
Jun	113.5	531.18	542.50	102.13
Jul	108	505.44	567.50	112.28
Aug	100.1	468.47	457.00	97.55
Sep	80.1	374.87	359.00	95.77
Oct	58.8	275.18	173.30	62.98
Nov	42.9	200.77	89.30	44.48
Dec	31	145.08	47.20	32.53
Yearly output	919.8	4,304.66	2,235.80	
Average Monthly		358.72	319.40	89.04
Average per day =11.5kWh Oliver 10.23kWh				

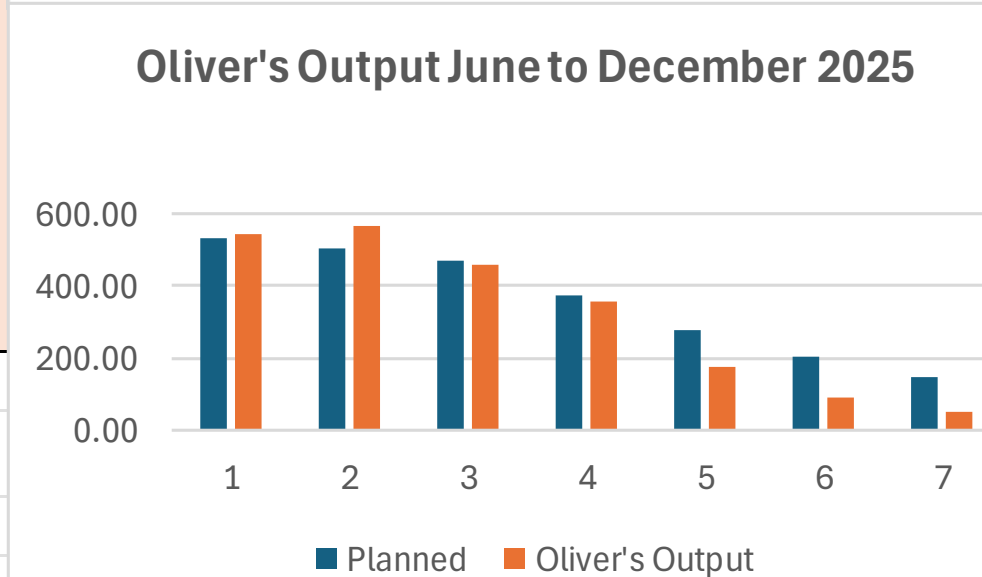
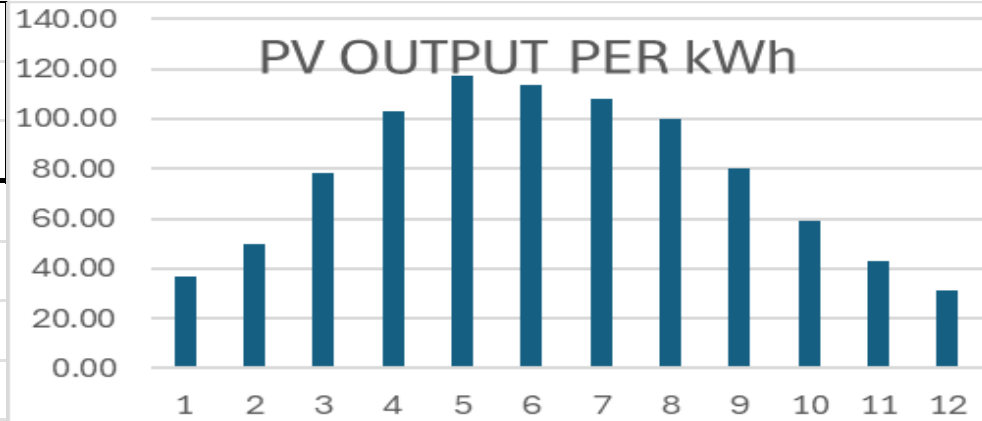

GRANGE HEIGHTS

PV OUTPUT 1 kWp (1000w) kWp		Installed capacity 106 houses 745 kW	
Month		Yearly output in kWh	
Jan	36.6	27,267	
Feb	49.9	37,176	
Mar	78.4	58,408	
Apr	103.1	76,810	
May	117.4	87,463	
Jun	113.5	84,558	
Jul	108	80,460	
Aug	100.1	74,575	
Sep	80.1	59,675	
Oct	58.8	43,806	
Nov	42.9	31,961	
Dec	31	23,095	
Yearly output	919.8	685251	kWh
@ 33c per kWh		226,133	Euro
@ 19.5c per kWh		133,624	Euro
@ 50/50 = (33+19.5)/2		181,592	Euro

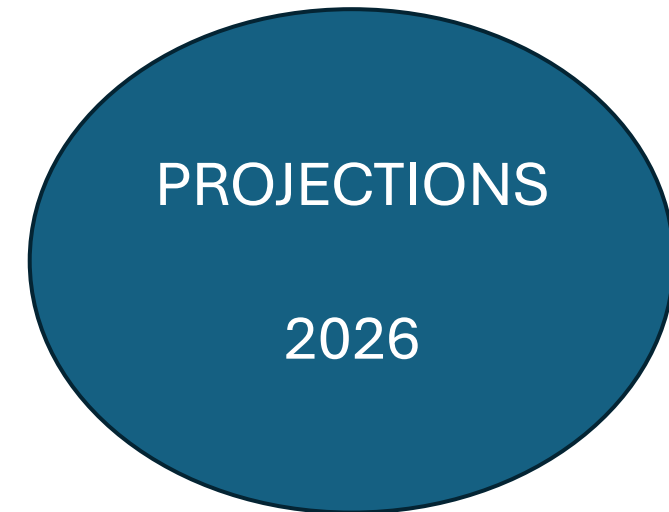

Crunching some numbers. In one NC-SEC model estate, we installed 745 kW of solar panels, which are expected to produce about **685,251 kWh** of electricity annually. If all electricity was used by households, the savings would be **€226,133** and if all were exported to the grid, the value to households would be **€133,628**. And, what if, 50/50 the value would be **€181,592**. The margin of error is +/- 5% as we cannot predict annual daily sunlight hours.

THE BIG PICTURE

IRELAND 2,200,000 HOUSES WITH ROOFTOPS

20% = 440,000 HOUSES WITH SOLAR PV BY 2030 FROM THE PRESENT 7%

IF 440,000 USE THE NATIONAL AVERAGE OF 4200kWh/ANNUM

@28c per kWh = $4200 \times .28 \times 440,000 = \text{€}522,144,000$ per annum

COMPANIES USE SO FAR BY SECs

Wizer Energy, Little Island (www.Wizerenergy.ie)

Ashgrove, Mallow (www.Ashgrove.ie)

ECO Green Resources, Blackpool (www.ERG.ie)

2026 Grant seai.ie

Solar - €1800

www.seai.ie

**NATIONAL HOME ENERGY UPGRADE
SCHEME FOR ALL GRANTS**

Etc.

What we have learnt

www.esbnetworks.ie **FOR INFO ON YOUR
ELECTRICITY USAGE –
DAY/WEEK/MONTH/YEAR**

**National Average: 4200kWh per year or
11.5kWh per day.**

What we have learnt, Contd.

Once you determine your energy usage in kWh for a Year: ADD 15% -20% TO DETERMINE THE SIZE OF YOUR SOLAR SYSTEM.



Example:

In 2025 – Used 4000kWh of electricity – add 15% = 4600kWh – go for 10x 500w panels =5kWp @90% efficiency = 4500kWh.

Wizer Energy Ltd
 Newton Court SEC - Client
Lot 2 8 Panel Split Array
Oliver Deasy 22 Newton Court Grange Douglas Cork T12 NT7P

Client No		1713						
Item No	Details	Unit Price	No of UNITS	Total Cost	Sub-totals		Household Balance Statement	
					Supplies	Wizer Installation		
1	Panels	60.00	8	480.00				
2	Inverter	379.00	1	379.00				
3	Mounting Brackets	145.00	set	150.00				
4	Cables and accessories	150.00	set	165.00	1,174.00			
5	Zeoluff Freight on Board	26.00	1	26.00	26.00			
6	Shipping and Transport	227.72	1	227.72	227.72			
7	Installation Wizer Energy	2,273.00	1	2,273.00				
8	BER	300.00	1	300.00		2,573.00		
9	SEAI Grant	1,975.00	1			2,100.00		
10	Wizer Costs after SEAI grant					473.00		
11	Remedial Work: (Extras)							
a	RCD	80.00	1	80.00			80.00	
b	MCB	80.00	1	80.00			80.00	
c	Bonding	100.00	1	100.00			100.00	
d							0.00	
e							0.00	
f							0.00	
g							0.00	
Totals					1,427.72	473.00	260.00	2,160.72
Total due to Wizer by Household								2,160.72
Paid by Household								2,100.00
Balance due by Household								-60.72

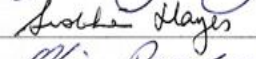
Newton Court SEC Approval of Account

Signed: (Any 2 of 3)
 Finbarr Buckley 
 Siobhan Hayes 
 Oliver Deasy 

Date

Notes Paid by NC-SEC for supplies 400 balance paid to Wizer for Supplies =

Summary	Credit	Debit
Paid by household	2,100.00	
Supplies / Shipping / Transport		1,427.72
Installation before SEAI grant		2,573.00
Remedial Work		260.00
Overall total		4,260.72
SEAI Grant	2,100.00	
Net Costs including remedial		2,160.72
Balance due by household	60.72	0.00
Balance SEC Account	2,160.72	0.00
Net cost before remeial work		1,900.72

887.72

THE RESULTS

PAID IN €2100
 ACTUAL COSTS €2160.72
 -60.72



GUIDE ON SOLAR PV FOR SECs

NEWTON COURT SUSTAINABLE ENERGY COMMUNITY GUIDE on SOLAR PV



Information (Guide) on Solar PV Scheme

What is a SEC?

A SEC is a **Sustainable Energy Community**, where household in one or more Estates or a Parish come together and register a SEC with SEAI for the purpose of sustainable energy in the community and home. Usually, SECs operate under the umbrella of a Resident's Association. And, in some cases can have a legal basis such as a Company Limited by Guarantee. (CLG).

<https://www.seai.ie/plan-your-energy-journey/for-your-community/sustainable-energy-communities/start-an-energy-community>

A Solar PV Scheme

A solar PV Scheme is where a community come together and implement a Solar PV scheme based on **economies of scale and competitive tendering**. For economies of scale the minimum number of houses in a scheme is 25, and for competitive tendering the number of local companies invited to tender for a solar PV scheme is 6 to 8.

What is Solar PV?

A solar PV (photovoltaic) system is a setup that uses the sun's energy to generate electricity for use in homes or businesses. It consists of **solar panels**, which capture sunlight and convert it into direct current (DC) electricity, and an **inverter**, which transforms the DC electricity into alternating current (AC) electricity that can power appliances. Excess power can be stored in a **battery**, sent to the **electrical grid**, or used to **heat water**.

<https://www.seai.ie/sites/default/files/publications/Homeowners-Guide-To-Solar-PV.pdf>

How many Solar Panel do I need?

The number of Solar Panels you need depends on household electricity usage in kilowatt hours (kWh). This you can find out by logging into <https://www.esbnetworks.ie> and go to tab **MY Account**. Set up your account using your MPRN number from your electric bill and you can see your household electricity usage per day, week, month and year. For example, the average household electricity usage in Ireland per year is 4200kWh in 2024.

If you're your household usage is 4200kWh per year then your installed Solar PV capacity should be 110 to 115% of your annual electricity usage. Modern solar panels range from 500w (watt) to 700w in installed capacity. Therefore, If I need to install 100% of annual electricity usage of 5000kWh then I need to install $5000 \times 115\% = 5750\text{kWh}$, say 12x500W panel is 6000kWh of installed capacity. 6000kWh at 85% efficiency will yield 5100kWh. Perfect for my needs. The next question is can I fit 12 x 500watt solar panels on my roof.

This document is prepared by Newton Court, Grange, Douglas, Cork, SEC, based on experience of setting up a SEC and installing Solar PV in one third of all houses in the estate.

oliver.deasy@gmail.com

oliver.deasy@gmail.com

- **For electronic version of the Solar PV Guide**
- **€10 goes to our SEC**