



# Cultural Heritage Guidelines for Electricity Transmission Projects

A Standard Approach to Archaeological,  
Architectural and Cultural Heritage  
Impact Assessment of High Voltage  
Transmission Projects



The current. The future.

## **TABLE OF CONTENTS**

Foreword

Acknowledgements

Summary

Preface

### **Part I BACKGROUND**

#### **1 Cultural Heritage Impact Assessment of High Voltage Electricity Transmission Projects**

1.1 Introduction

1.2 Key Considerations for Heritage Assets

1.2.1 Existing Heritage Guideline Documents in Ireland

1.2.2 Statutory Protection of Heritage Assets

1.2.2.1 National Protection of Heritage Assets

1.2.2.2 European Protection of Heritage Assets

1.3 Requirements of a Cultural Heritage Consultant

1.4 Description of Typical Electricity Transmission Project Designs

1.4.1 Overhead lines (OHL)

1.4.2 Structure Design

1.4.3 Underground Cabling (UGC)

1.4.4 Substations

#### **2 Potential Impacts of High Voltage Electricity Transmission Projects on Cultural Heritage Assets**

2.1 Introduction

2.2 Types of Impact

2.3 Potential Impact on Setting (direct and indirect impacts)

2.4 Assessment of Setting

2.5 Summary of Setting

2.6 Cumulative Impacts

2.7 Construction Impacts

I. Overhead Transmission Line Construction (OHL)

II. Underground Cables (UGC)

III. Substations

2.8 Operational impacts

2.9 Summary of Potential Impacts

---

**Part II PLANNING AND GUIDANCE****3 The Planning of Electrical Transmission Projects and Guidance on Cultural Heritage Assets at Each Stage of Impact Assessment**

- 3.1 Planning and Design Procedures
- 3.2 Project Development
- 3.3 Consultation

**4 Cultural Heritage Requirements: Step 1 & 2**

- 4.1 Introduction
- 4.2 Step 1: Cultural Heritage Constraints Study
  - 4.2.1 Constraints Study Approach
  - 4.2.2 Contents of the Constraints Study Report
  - 4.2.3 Mapping of all Cultural Heritage Constraints
  - 4.2.4 Consultation
  - 4.2.5 Constraints Study Checklist
- 4.3 Step 2: Route Corridor/Site Options Assessment
  - 4.3.1 Route Corridor Approach
  - 4.3.2 Identification of Cultural Heritage Assets
  - 4.3.3 Inventory of Cultural Heritage Constraints
  - 4.3.4 Comparison of Route Corridor Options
  - 4.3.5 Summary Route Corridor Matrix
  - 4.3.6 List of Sources Consulted
  - 4.3.7 Consultation
  - 4.3.8 Report Format
  - 4.3.9 Route Corridor Selection Study Checklist

**5 Cultural Heritage Requirements : Step 3 Preferred Corridor /Preferred Site Evaluation**

- 5.1 Preferred Corridor/Preferred Site Evaluation
- 5.2 Preferred Route/Preferred Site Evaluation Checklist

**6 Cultural Heritage Requirements: : Step 4 Cultural Heritage Impact Assessment**

- 6.1 Introduction
- 6.2 Approach
  - 6.2.1 Consultation
  - 6.2.2 Description of the Existing Environment
  - 6.2.3 Survey Requirements
  - 6.2.4 Assessing Impact
    - 6.2.4.1 Impact prediction
    - 6.2.4.2 Impact Level
  - 6.2.5 Impact Assessment on Cultural Heritage Assets and Setting
  - 6.2.6 Inventory
  - 6.2.7 Description of Mitigation Measures
    - 6.2.7.1 Mitigation by Avoidance
    - 6.2.7.2 Mitigation by Reduction or Design
    - 6.2.7.3 Mitigation by Remedy
- 6.3 Report Format
- 6.4 Study Checklist

## 7 Environmental Management Plan: Step 5

- 7.1 Construction Environmental Management Plan
- 7.2 Practical Considerations
- 7.3 Provision of Cultural Heritage Consultancy Services
- 7.4 Cultural Heritage Consultancy Services – Pre-Construction
- 7.5 During Construction
  - 7.5.1 Uncovering a National Monument
  - 7.5.2 Demolition of a National Monument
  - 7.5.3 Post-Excavation
- 7.6 Operational phase – Maintenance Refurbishment & Upgrading

## 8 References

### Figures

- Figure 4.1** Example of an Architectural Heritage Constraints Map
- Figure 4.2** First Edition Ordnance Survey 6-inch Map
- Figure 4.3** Example of Mapping Showing Recorded Monuments Within Identified Potential Route Corridors
- Figure 4.4** Example of Mapping Showing Records of Protected Structures Within and Adjacent to Identified Potential Route Corridor
- Figure 6.1** First Edition Ordnance Survey 6-inch Mapping

### Tables

- Table 1.1** Key Design Features: Single Circuit 220 kV and 400 kV overhead line support structures
- Table 1.2** Key Design Features: Single Circuit 110 kV overhead line support structures
- Table 1.3** Key Design Features: Underground Cabling
- Table 2.1** Checklist for Assessing the Contribution of Setting to the Significance of a Heritage Asset (after English Heritage 2011)
- Table 2.2** Checklist for Assessing Impact on Cultural Heritage Assets (adapted from English Heritage for Transmission Projects)
- Table 2.3** Summary of Potential Construction and Operational Impacts
- Table 3.1** Summary of the Cultural Heritage Steps to be Considered in Planning EirGrid's Major Transmission Projects
- Table 3.2** Statutory Consultees

|                  |  |
|------------------|--|
| <b>Table 4.1</b> | A Sample Entry from a Route Corridor Inventory               |
| <b>Table 4.2</b> | Example of a Route Corridor Summary Matrix                   |
| <b>Table 6.1</b> | Sample Impact Evaluation Checklist                           |
| <b>Table 6.2</b> | A Sample Entry from a Cultural Heritage Inventory for EIS/ER |

### **Appendices**

|            |   |
|------------|---|
| Appendix 1 | Glossary of Terms   |
| Appendix 2 | Glossary of Impacts   |
| Appendix 3 | Statutory Consultees  |
| Appendix 4 | Range of Heritage Assets, Environments and Landscapes             |
| Appendix 5 | EirGrid Recording Form and Checklists                             |
| Appendix 6 | Typical Overhead Electricity Structures 110 kV, 220 kV and 400 Kv |
| Appendix 7 | Typical Cabling Structures  |



## FOREWORD

I am delighted to publish these Cultural Heritage Guidelines for Electricity Transmission Projects.

The Guidelines outline the principles to be applied for the protection of Ireland's Cultural Heritage as we develop Ireland's electricity grid. They have been prepared by Courtney Deery Heritage Consultancy Ltd in consultation with the Department of Arts, Heritage and the Gaeltacht (DAHG) and ESB Networks.

It is EirGrid's responsibility to ensure Ireland has the electricity transmission infrastructure it needs. We develop the grid to help Ireland remain competitive. Our work also fosters economic growth, attracts new investment and supports indigenous jobs. We must do this without placing too great a burden on communities, or too high a cost on industry. Our goal is to always find a fair balance between these factors. It is also our responsibility to obtain planning consent for new network developments.

The existing high voltage transmission network system includes approximately 6,500 km of circuits ranging from 400 kilovolts (kV) to 110 kV and over 100 substations.

We need to develop the transmission grid to guarantee a secure supply of electricity now and for future generations, and to facilitate local, national and European policies relating to renewable energy. This will require the building of new transmission lines, cables and stations, line upgrades and refurbishments.

These guidelines are designed to ensure these developments are carried out in an environmentally sensitive manner, including the protection of our cultural heritage.



John Fitzgerald,  
Director of Grid Development & Interconnection,  
EirGrid

**October 2015**

## ACKNOWLEDGEMENTS

The authors, Lisa Courtney and Siobhan Deery of Courtney Deery Heritage Consultancy Ltd, would like to express their gratitude to the individuals and organisations that provided advice, recommendations and information for these Guidelines.

In particular, the authors would like to thank:

**The National Monuments Service, Department Arts, Heritage and the Gaeltacht (DAHG)**  
**The Architectural Heritage Advisory Unit, Department Arts, Heritage and the Gaeltacht (DAHG)**  
**The Heritage Council**

The authors gratefully acknowledge the assistance provided by Dr. Maeve Flynn and Des Cox at EirGrid. Contributions and direction received from EirGrid Grid Development Managers, ESB Networks and ESB International (ESBI) is also acknowledged.

We would also like to thank the heritage and conservation officers and heritage consultants who gave their time and expertise to inform this process.

## DISCLAIMER

**While every care has been taken to ensure that the content is useful and accurate, EirGrid plc, and any contributing third party, shall have no legal responsibility for the content or the accuracy of the information so provided or for any loss or damage arising directly or indirectly in connection with reliance on the use of such information.**



**View of the River Shannon from Co Clare towards Co. Kerry**

## SUMMARY

Cultural heritage, archaeological heritage, and architectural heritage are places and objects of beauty, cultural, historic, scientific, social or spiritual value. They include archaeological monuments, world heritage sites, protected structures, designed landscapes, place names, language and inherited traditions.

These Guidelines have been developed to standardise the approach for cultural heritage (including archaeological heritage and architectural heritage) impact assessment in the planning, design, construction, and operation of high voltage (110 kV, 220 kV and 400 kV) electricity transmission projects undertaken by EirGrid.

The process of routeing electricity transmission projects is a complex one that must achieve a balance between technical and other engineering requirements, costs, and environmental (including cultural heritage) issues.

In order to assess the likely significant impact of transmission line infrastructure on cultural heritage assets, the cultural heritage consultant must understand the characteristics of this infrastructure during both its construction and operation. The Guidelines outline typical technologies (overhead line, underground cable, substations) and construction techniques used in developing our projects.

The Guidelines are based on published national and international best practice guidance and legal obligations in relation to the identification, protection and avoidance of heritage assets.

Potential effects on cultural heritage assets can generally be avoided through careful routing and/or site selection. This requires early consultation, and the implementation of the Code of Practice agreed between EirGrid and the then Department of Environment, Heritage and Local Government; this outlines a commitment to avoid archaeology where possible. Field survey and investigatory work are also very important for the early identification of features and areas of significance.



Assessments of effects on cultural heritage assets must also include consideration of effects on the wider cultural heritage landscapes, within which those assets are located – their “setting”. The planning and design of a transmission project can play a vital role in maintaining a site’s setting. The setting of heritage assets should therefore be considered at the earliest stages of transmission design.

The identification of potential impacts at the earliest opportunity allows for an evaluation of cultural heritage concerns to be properly addressed and integrated into the planning system. This procedure also reduces or avoids the negative impacts of the final route on the existing heritage environment.

The starting point is to establish the heritage assets that are likely to be affected by a development proposal. Not all heritage assets will be impacted in the same way, some will be more sensitive to change affecting their setting than others. The next step is to assess whether, how and to what degree the setting of the heritage asset(s) influences the significance of the asset. This can incorporate its physical surroundings, its relationship with other heritage assets, the way the asset is appreciated, and its associations and patterns of use.

The construction of transmission projects involves both temporary and permanent impacts. Permanent impacts exist as long as the line is in place, while temporary impacts occur during construction or during maintenance and uprating works. For transmission circuits, the extent of the land disturbed during construction is greater than that during site operation when disturbance caused by construction has been reinstated.

Where impacts are unavoidable, a variety of measures can be introduced to overcome or generally lessen the impact. The most appropriate measures will be implemented following consultation with the cultural heritage consultant and agreement with the statutory authorities.

Guidance on how to approach the planning and undertaking of a cultural heritage impact assessment for high voltage transmission projects is provided in the Guidelines. The approach is based on professional judgement, and reference to best practice.

An Environmental Impact Statement (EIS) must include assessment of the cultural heritage. Even where an EIS is not required in respect of a project, that project should still include a cultural heritage assessment.

The specific design and siting of an electricity transmission project is an evolving process, from broad considerations of the area where the project could feasibly be located, to the specific route or site of a proposed development. These Guidelines identify a number of steps for the appropriate and comprehensive consideration of cultural heritage.

Consultation with statutory and non-statutory bodies as well as with the general public and other stakeholders is an essential part of the cultural heritage impact assessment process. It is important that consultation is initiated at the earliest stages of the planning process as the resulting information can inform and guide the assessment process.

## PREFACE

These Guidelines have been developed to standardise the approach for cultural heritage impact assessment in the planning, construction and operation of high voltage (110 kV, 220 kV and 400 kV) electricity transmission projects. A standardised approach will assist practitioners in providing robust assessments and consistency between projects upon which the relevant adjudicating authority can make a decision in a clear, transparent and practical way.

The Guidelines are based on published national and international best practice, and legal obligations in relation to heritage assets, and will be updated to reflect any changes in the legislation where it relates to the protection of cultural heritage.

The EirGrid Evidence Based Study on Cultural Heritage Assets (examining the actual effects of the construction, existence and operation of high voltage transmission projects) prepared by Courtney Deery Heritage Consultancy Ltd (2014), provides baseline information to inform the guidance in terms of planning and design.

These Guidelines serve to strengthen the relationship between the Minister of Environment, Heritage and Local Government, EHLG (now Arts, Heritage and the Gaeltacht, AHG) and EirGrid, and build upon the successful partnership that resulted in the publication of a Code of Practice between the Minister and EirGrid in 2009. As agreed in this Code of Practice, EirGrid is committed to working with the Minister and the National Monuments Service in order to protect our heritage.

### Guidelines Objectives

The purpose of the Cultural Heritage (including archaeological heritage and architectural heritage) Guidelines on high voltage electricity transmission projects (110 kV, 220 kV and 400 kV) is to:

- standardise the approach for all cultural heritage impact assessment during the planning process.
- assist with the formulation of a consistent, best practice approach to heritage at all stages of transmission projects.

The Guidelines are presented in two parts:

**Part 1** introduces the objectives of the Guidelines. It sets out the key considerations for cultural heritage impact assessment including the legislative framework, and the statutory planning processes. It characterises cultural heritage and the types of 'heritage asset' that require identification and protection during the planning and construction phases of a project, and the requirements of a cultural heritage consultant.

Typical infrastructure, technologies and construction techniques for a transmission system are outlined, and how each aspect may directly or indirectly impact on heritage assets, is discussed. Part 1 also provides an assessment of criteria to be considered in relation to the setting of heritage assets.

**Part 2** of the document outlines planning and design procedures associated with the development of a transmission project. It also provides detailed technical guidance on the assessment of cultural heritage throughout the planning and design process for transmission projects. The document concludes with recommendations to assist in the preparation of cultural heritage consultancy practices post EIS/ER as part of a Construction Environmental Management Plan (CEMP).



A section of the 220 kV Cashla – Flagford overhead line with a platform ringfort site in the foreground (R0022-056048), Co Roscommon

## **PART I BACKGROUND**

### **1. Cultural Heritage Impact Assessment of High Voltage Electricity Transmission Projects**

#### **1.1 Introduction**

As the statutory Electricity Transmission System Operator (TSO), EirGrid holds responsibility for the planning, development and operation of Ireland's high voltage transmission network, and is the Electricity Market Operator (EMO) of the wholesale electricity trading system. EirGrid's role is to deliver quality connection, transmission and market services to electricity generators, suppliers and customers utilising the high voltage electricity system, and to develop the transmission grid infrastructure required to support the development of Ireland's economy.

ESB Networks, as the Transmission Asset Owner (TAO), is charged with constructing the transmission assets as specified by the TSO, and with which the TSO coordinates planning and development requirements. ESB Networks also has the role of Distribution System Operator (DSO), referring to the medium and lower voltage electricity distribution network.

The existing high voltage transmission system comprises approximately 6,500km of overhead lines and underground cables and over 100 transmission substations. High voltages (HV) are used to avoid power losses, which would otherwise occur when transferring power over long distances via a lower voltage system. The transmission grid in Ireland is made up of circuits and equipment at three voltage levels: 400 kV, 220 kV and 110 kV.



**TRANSMISSION SYSTEM**  
400, 275, 220 AND 110kV  
JANUARY 2015

- 400kV Lines
- 275kV Lines
- 220kV Lines
- 110kV Lines
- - - 220kV Cables
- - - 110kV Cables
- - - HVDC Cables
- 400kV Stations
- 275kV Stations
- 220kV Stations
- 110kV Stations

- Transmission Connected Generation**
- Hydro Generation
  - Thermal Generation
  - ▲ Pumped Storage Generation
  - Wind Generation

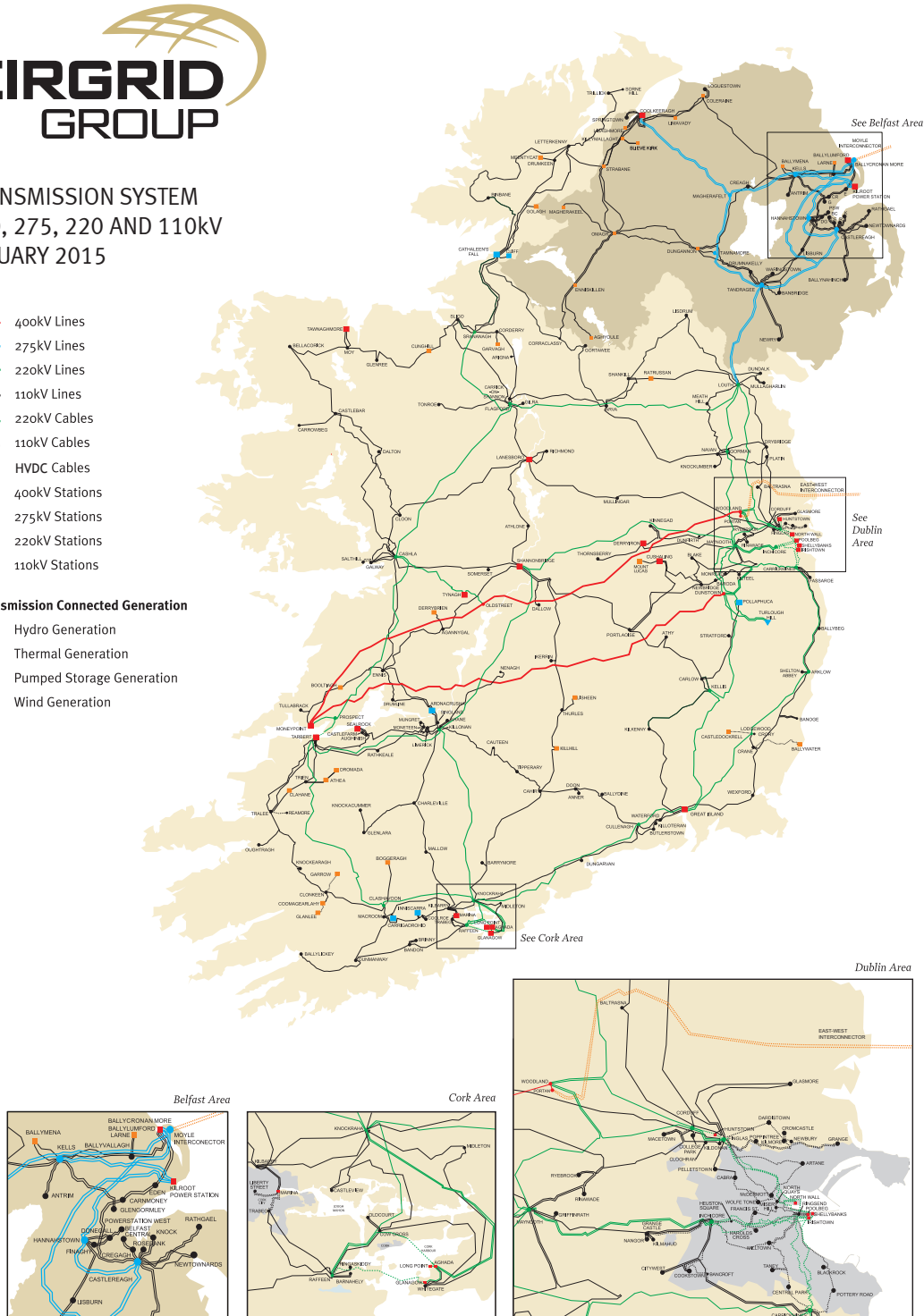

EirGrid's statutory function includes developing a safe, secure, reliable, economic and efficient power system in Ireland. Under the Code of Practice agreed in 2009 by EirGrid and the then Minister for the Environment, Heritage and Local Government, EirGrid is committed to the preservation of archaeological heritage and ensuring that proposed developments are undertaken in an environmentally sensitive manner, protecting our cultural heritage (NMS 2009). Proper planning and assessment will ensure that cultural heritage is protected during the design and construction of projects.

For the purposes of these Guidelines the many aspects of cultural heritage are described collectively as *cultural heritage assets*.

**Cultural Heritage Assets** comprising archaeological heritage, architectural heritage & cultural heritage are part of our cultural identity as a nation, having both a dynamic physical expression in the landscape & also a non-tangible expression. They are places and objects of aesthetic, cultural, historic, scientific, social or spiritual value. They include recorded archaeological monuments (RMP), national monuments, UNESCO world heritage sites (WHS), tentative WHS known & unknown surface & subsurface archaeological remains, protected structures, designed landscapes, architectural conservation areas (ACAs), NIAH building and garden survey sites, structures of architectural heritage merit (vernacular, urban and rural), cultural heritage features, placenames, language and inherited traditions.

The Guidelines are based on current best international practice and legal obligations in relation to cultural heritage assets (including setting); they have regard to existing published guidelines, both in Ireland and internationally, which are described below, and to the findings of the EirGrid Cultural Heritage Evidence-Based Study (EirGrid 2014). This study was commissioned by EirGrid to provide an authoritative, evidence based assessment of the actual effects of the construction, existence and operation of high voltage transmission projects in Ireland on archaeological, architectural and cultural heritage assets. The study is intended to form part of a suite of multidisciplinary studies and will inform future guidance in terms of planning and design and construction of transmission infrastructure.

The objectives for the Cultural Heritage Evidence –Based Study were:

- To carry out direct, meaningful and useful field based studies that will have a practical application in future planning reports and processes.
- To provide evidence for the type of route, design, construction and maintenance methods that will give rise to the least impact on cultural heritage features.
- To establish the impacts (if any) of existing 400 kV, 220 kV and 110 kV, power lines and all other associated structures and ancillary services on the cultural environment in Ireland, by surveying and assessing agreed representative sections of established power lines.
- To provide a factual basis for subsequent Evidence-Based Design Guidelines for power transmission projects in Ireland.

The study found that the potential effects on cultural heritage assets and historic landscapes can generally be avoided through careful routing and substation site selection exercises, early and appropriate consultation, and the implementation of the Code of Practice, agreed between EirGrid and the Department of Environment, Heritage and Local Government in 2009.

These Guidelines are aimed at project managers, engineers, planners and for all members of the professional teams, including cultural heritage specialists, archaeologists and architectural heritage consultants involved in the planning and development of electricity transmission infrastructure. It describes how to document the decision-making process for cultural heritage assets in a non-technical manner, thereby making it accessible to non-specialists.

## 1.2 Key Considerations for Heritage Assets

The Irish landscape is rich in physical archaeological, architectural and cultural heritage remains. Each recorded monument and protected structure provides a unique cultural record in itself as a carrier of memory, meaning and cultural value. When considered in the context of its surroundings, each can form an essential component in the mechanism for analysing the wider cultural character and context of an area. Together, these can assist in mapping the evolution and changes that have led to the development of the modern environment. Such analysis also provides insight into the communication, trade, transport, growth and associations of past human societies. Cultural assets are valued for the important contribution they make to our understanding of the history of a place, an event or a people.

Cultural assets are described in the EPA *Guidelines on information to be contained in EIS* (EPA 2002) as material assets and include ‘... *architectural and archaeological heritage and cultural heritage*’ and the following range of topics are listed to be considered under the material assets heading:

*‘archaeological heritage, folklore/ tradition/ history, architecture/settlements, monument/ features, designed landscape, natural resources of economic value, building and structures and infrastructures’.*

For the purpose of these Guidelines, the terms archaeology, architectural heritage, cultural heritage are defined as follows –

**‘Archaeology’** *‘is the study of past societies through the material remains left by those societies and the evidence of their environment. The ‘archaeological heritage’ consists of such material remains (whether in the form of sites and monuments or artefacts in the sense of moveable objects) and environmental evidence’<sup>1</sup>.*

Section 2 of the National Monuments Acts 1930 (as amended) provides that ‘monument’ includes the following (whether above or below the surface of the ground or the water and whether affixed or not affixed to the ground):

- ‘(a) any artificial or partly artificial building, structure or erection or group of such buildings, structures or erections,*
- (b) any cave, stone or other natural product, whether or not forming part of the ground, that has been artificially carved, sculptured or worked upon or which (where it does not form part of the place where it is) appears to have been purposely put or arranged in position,*
- (c) any, or any part of any, prehistoric or ancient-*
  - (i) tomb, grave or burial deposit, or*
  - (ii) ritual, industrial or habitation site, and*
  - (iii) any place comprising the remains or traces of any such building, structure or erection, any such cave, stone or natural product or any such tomb, grave, burial deposit or ritual, industrial or habitation site, situated on land or in the territorial waters of the State’*

<sup>1</sup> Framework and Principles (DAHGI), 1999, pg 9

**'Architectural heritage'** is defined as *'all structures and buildings (together with their settings and attendant grounds, fixtures and fittings, groups of such structures and buildings and sites), which are of architectural, historical, archaeological, artistic, cultural, scientific, social or technical interest. Architectural heritage is generally visible and has a presence in the landscape which requires assessment'*<sup>2</sup>.

**'Cultural heritage'** is a general term used to describe aspects of the environment and intangible heritage which are valued for their age, beauty, history or tradition. It encompasses aspects of archaeology, architecture, history, landscape and garden design, folklore and tradition and topography. Cultural heritage is expressed in the physical landscape in numerous often interrelated ways.

### 1.2.1 Existing Heritage Guideline Documents in Ireland

In Ireland there are a number of guidance documents issued by the government, local authorities and utility developers to assist in identifying, protecting and avoiding heritage assets. These guidelines also assist in standardising the approach taken during planning and design stages of infrastructural schemes.

The following guidance documents assist in the decision making process when assessing heritage assets:

*Framework and Principles for the Protection of the Archaeological Heritage (1999) (DAHGI)*

*Policy and Guidelines on Archaeological Excavation (1999) (DAHGI)*

*Forestry and Archaeology Guidelines for the Forest Service (2000)*

*Code of Practice between the Minister of the Environment, Heritage and Local Government and EirGrid in relation to Archaeological Heritage (2009) (NMS)*

*Code of Practice between the Minister of Environment, Heritage and Local Government and ESB Networks in relation to Archaeological Heritage (2009) (NMS)*

*Guidelines for the Testing and Mitigation of the Wetland Archaeological Heritage for National Road Schemes (2005c) (NRA)*

*Guidelines for the Assessment of Archaeological Heritage Impacts of National Road Schemes (2005a) (NRA)*

*Guidelines for the Assessment of Architectural Heritage Impacts of National Road Schemes (2005b) (NRA)*

*Architectural Heritage Guidelines for Planning Authorities (2011) (DAHG)*

*Guidance Notes for the appraisal of historic gardens, demesnes, estates and their settings (2006) (Cork County Council)*

*NIAH illustrated publications provide an introduction to architectural heritage in each surveyed area, [www.buildingsofireland.ie](http://www.buildingsofireland.ie)*

<sup>2</sup> Architectural Heritage Protection Guidelines for Local Authorities 2011



*Advice Notes on Current Practice in the Preparation of Environmental Impact Statements (2003) (EPA)*

*Guidelines on the information to be contained in Environmental Impact Statements (2002) (EPA)*

*Project Management Guidelines (2010) (NRA)*

*Wind Energy and the Historic Environment (2005) (English Heritage<sup>3</sup>)*

*The Setting of Heritage Assets, English Heritage Guidance (2011) (English Heritage) (superseded by Historic Environment Good Practice Advice in Planning Note 3: The Setting of Heritage Assets, (March 2015) Historic Landscape Characterisation in Ireland: Best Practice Guidance (2013) (Heritage Council)*

*County Heritage Plans*

### 1.2.2 Statutory Protection of Heritage Assets

Ireland protects heritage assets through the following legislation and has ratified a number of international conventions and agreements in relation to archaeology, built and cultural heritage.

National Monuments Act, 1930, as amended in 1954, 1987, 1994, 2004 and 2012

Heritage Act, 1995

The Architectural Heritage (National Inventory) and Historic Monuments (Miscellaneous Provisions) Act, 1999

Local Government (Planning and Development) Act, 2000 (as amended)

Council of Europe *Convention for the Protection of the Architectural Heritage of Europe* (Granada) 1985, ratified by Ireland in 1991

Council of Europe *European Convention on the Protection of the Archaeological Heritage* (Valletta) 1992, ratified by Ireland in 1997

*The Burra Charter*, the Australia ICOMOS Charter for Places of Cultural Significance 1999

UNESCO *Convention concerning the Protection of World Cultural and Natural Heritage* 1972, ratified by Ireland in 1991

ICOMOS *Xi'an Declaration on the Conservation of the Setting of Heritage Structures, Sites and Areas*. Paris: International Council on Monuments and Sites, 2005

---

<sup>3</sup> Now Historic England

### 1.2.2.1 National Protection of Heritage Assets

#### Archaeological Monuments

The National Monuments Act, 1930 and subsequent amendments provide the formal legal mechanisms to protect monuments in Ireland. There are four mechanisms by which a monument is protected under the Acts; these are:

- The Record of Monuments and Places (RMP)
- The Register of Historic Monuments (RHM)
- Preservation Order (PO) or Temporary Preservation Order (TPO)
- National Monuments (NM) either in the care (ownership or guardianship) of the State or a local authority

All known sites and monuments in Ireland are identified and listed for protection in the Record of Monuments and Places (RMP). This is a statutory inventory of sites protected under the National Monuments Acts.

The prior written consent of the Minister is required for any works at, or in proximity to, a National Monument in the ownership or guardianship of the State, the Minister or a local authority, or those which are subject to a Preservation Order.

#### Protected Structures

A protected structure is a structure that is considered to be of 'special interest', which is broadly defined by the Planning and Development Act, 2000 as structures of architectural, historical, archaeological, artistic, cultural, scientific, social or technical point interest. The 2000 Act requires each planning authority to compile and maintain a Record of Protected Structures (RPS). The RPS is a mechanism for the statutory protection of the architectural heritage and is listed in every County Development Plan and Town Development Plan.

By definition, a protected structure includes the land lying within its curtilage and other structures within that curtilage and their interiors. The notion of curtilage is not defined by legislation, but according to the Architectural Heritage Protection Guidelines for Planning Authorities (2011) it is that parcel of land immediately associated with the structure and which is (or was) in use for the purpose of the structure. The attendant grounds of a structure are the lands outside the curtilage of the structure but which are associated with the structure and are intrinsic to its function, setting and/or appreciation.

#### Architectural Conservation Areas

Architectural Conservation Areas (ACA) are places, groups of structures or townscapes that are of special architectural, historical, archaeological, artistic, cultural scientific, social or technical interest/value or contribute to the appreciation of Protected Structures. ACAs and candidate ACAs are listed in every County Development Plan and Town Development Plan.



Special social interest may be attributed to Ardnacrusha generating station, Co. Clare. This marked the commencement of rural electrification. [www.esb.ie](http://www.esb.ie)

### National Inventory of Architectural Heritage

The National Inventory of Architectural Heritage (NIAH) places a statutory basis under the provisions of the Architectural Heritage (National Inventory) and Historic Monuments (Miscellaneous Provisions) Act 1999. The NIAH's role is to identify record and evaluate the post-1700 architectural heritage of Ireland. It aims to promote the appreciation of, and contributes to the protection of, the built heritage by systematically recording a representative sample of that built heritage on a nationwide basis<sup>4</sup>. The surveys provide the basis for the recommendations of the Minister to planning authorities for the inclusion of particular structures in the Record of Protected Structures (RPS).

### The Historic Garden and Designed Landscape Survey (NIAH)

Historic landscapes, gardens and demesnes are usually, but not always, associated with Protected Structures and therefore do not always have statutory protection. The NIAH Designed Landscapes and Historic Gardens Survey is a preliminary non-statutory survey, based on a paper study using historic map sources and aerial photography<sup>5</sup>.

---

<sup>4</sup> [www.buildingsofireland.ie](http://www.buildingsofireland.ie)

<sup>5</sup> [www.buildingsofireland.ie/survey/gardens](http://www.buildingsofireland.ie/survey/gardens)



**A view of a section of the 110 kV Lanesboro – Shannonbridge overhead line, Co Roscommon showing the bridge and bastioned fort, both protected structures and recorded monuments. Many structures are of both architectural and archaeological interest and suitable for protection under the Planning Acts in addition to the National Monuments Acts**

### Cultural Heritage

Cultural heritage is a broad term that now has come to include a wide range of tangible and intangible cultural considerations that are bound up in cultural memory and associations, belief, traditions, past knowledge, traditional and arcane practices, craft and building skills, and the oral tradition of local populations.

For example cultural heritage can be expressed in the physical landscape as

- settlements (form, material composition and particular responses to the physical environment)
- designed landscapes
- natural resources of economic value (industrial/ farming sites e.g. mining sites, caves, mills, weirs, and fish passes etc.)
- building & structures (outside of NIAH and RPS)
- infrastructure (coach roads, military roads etc.)

Cultural Heritage is also expressed in non-physical ways, for example:

- in folklore
- inherited traditions (pilgrim paths, pattern day routes, historical county fairs or long established sporting activities and traditional country pursuits)
- language, values, townland and place names, memories
- history/ historical events (eg battle sites, association with historic personalities)

By identifying, recording and articulating these sensitive cultural heritage values they can be considered, respected and protected in the context of change in the future.

### **Historic Landscapes**

In April 2010 the Government approved a draft scheme of legislation which will, if enacted, repeal and replace the existing National Monuments Acts 1930 to 2004 and a number of associated Acts.

The Bill, if enacted, will form a single piece of consolidated legislation which will replace the existing acts and will afford additional protection for heritage and historic cultural landscapes.

There will be two levels of protection for historic landscapes. The first level will include a small number of iconic landscapes, to be known as Outstanding Historic Landscapes. The second level will be comprised of Special Historic Landscapes; these will be more locally based historic landscapes, mainly complexes of archaeological monuments. The Planning Acts will be amended to acknowledge the existence of 'Outstanding' and 'Special' historic landscapes and it will be the duty of the local authorities to conserve them.

The Bill provides that, similar to monuments, a landscape will not attract automatic protection simply by virtue of the fact that it fits the definition. The issue of statutory recognition will be restricted through the set criteria and expert advice that the Minister applies prior to designation.

### **Landscape Character Areas**

Landscape Character Assessment (LCA) is a process which describes, maps and classifies landscapes. It is a mechanism for enhancing local distinctiveness and promoting sustainable development. It is being developed on a county basis by individual local authorities through the structure of County Development Plans in response to the European Landscape Convention. Historic landscape characterisation (HLC) is a method for understanding and mapping the existing landscape with reference to its historical development.

### **Setting and Visual Amenity**

As well as the physical preservation of a monument, the protection of the amenity of the monument or structure can be fundamental to its significance.

The importance of setting lies in what it contributes to the significance of the heritage asset. An understanding of how to characterise the unique setting of a heritage asset is essential in order to accurately evaluate the effect of change on its setting and to define how the cultural significance of a heritage asset might be altered by that change.

In the National Monuments Acts the amenity of a monument is mentioned but is not explicitly defined:

*'National monument' "means a monument or the remains of a monument the preservation of which is a matter of national importance... And the said expression shall be construed as including in addition to the monuments itself, the site of the monument and the means of access thereto and also such portion of land adjoining such site as may be required to fence, cover in, or otherwise preserve from injury the monument or to preserve the amenities thereof"*<sup>6</sup>

The amenity of a monument has however been enshrined in law in a Supreme Court judgement relating to development in the vicinity of a monument:

*"If a particular area be identified as an area for conservation for any amenity reason, one does not then legitimately permit development to the very boundary of the area; either the area must itself be prescribed as extending to a sufficient circumference as will allow for a fallow area in between, or must envisage that such fallow area shall adequately extend outside the immediate area of the amenity."*<sup>7</sup>

In England, setting is defined in planning policy as *'the surroundings in which the heritage asset is experienced. Its extent is not fixed and may change as the asset and its surroundings evolve. Elements of setting may make a positive or negative contribution to the significance of an asset, may affect the ability to appreciate that significance or may be neutral'*<sup>8</sup>.

### **The Code of Practice between the Minister of EHLG (now AHG) & EirGrid in relation to Archaeological Heritage (2009)**

The Code of Practice outlines the principles and measures to be applied to ensure the protection of Ireland's archaeological heritage whilst developing and upgrading the existing transmission system. It is generally guided by the following principles:

- Every effort will be made to avoid direct impacts on archaeology;
- Mitigatory planning will take place at the earliest opportunity as it minimises the impact on the archaeological heritage;
- EirGrid and the Minister of AHG will co-operate to ensure, as far as possible, that appropriate archaeological investigation is carried out during the period from route identification to the commencement of construction;
- If avoidance cannot be achieved, EirGrid will finance a balanced and cost effective approach to archaeological investigation, excavation and mitigation as an integral element of the transmission system development programme.

---

<sup>6</sup> *National Monuments Act, 1930. Section 2*

<sup>7</sup> McCarthy J. in the case of *Attorney General (McGarry) v Sligo County Council* [1991] 1 I.R. 99. (In relation to a proposal to operate a refuse dump within Carrowmore megalithic cemetery and also on the concept of 'fallow area' around it).

<sup>8</sup> National Planning Policy Framework 2012, Annex 2: Glossary (Government Planning Policy for England)

The Code of Practice that EirGrid has agreed with the Minister safeguards and protects archaeology and outlines a commitment to avoid archaeology where possible.

The Minister has also agreed a Code of Practice with ESB Networks (2009) which sets out protection measures for archaeology.

### 1.2.2.2 European Protection of Heritage Assets

The importance of protecting the setting of heritage assets is recognised by a number of international conventions and instruments. The 'Valletta and Granada' Council of Europe conventions place legal obligations on Member States in relation to recording, conservation and management of archaeological and built heritage. In essence these conventions prescribe that heritage is conserved and maintained preferably *in-situ* and that archaeological and architectural heritage concerns are integrated into the planning and development process, for example through the Environmental Impact Assessment process. In Ireland these conventions are given effect through the National Monuments Acts 1930-2012, and the Planning and Development Act 2000 and its amendments.

The Valetta Convention requires the State *'to ensure that environmental impact assessments and the resulting decisions involve full consideration of archaeological sites and their settings'*.

The Granada Convention requires that *'In the surroundings of monuments, within groups of buildings and within sites, each Party undertakes to promote measures for the general enhancement of the environment'*.

The European Landscape Convention promotes landscape as a primary aspect of heritage and defines landscape as

*'an area, as perceived by people, whose character is the result of the action and interaction of natural and /or human factors'*.

The use of historic landscape characterisation (HLC) as a mechanism for large scale heritage management has been adopted by many European countries.

The Xi'an Declaration on the Conservation of the Setting of Heritage Structures, Sites and Areas (ICOMOS 2005) is the only international instrument dedicated to setting.

## 1.3 Requirements of a Cultural Heritage Consultant

The survey and assessment of heritage assets for the purposes of cultural heritage impact assessments requires a suitably qualified consultant with a minimum qualification of a degree or higher in archaeology and /or architectural heritage conservation. The consultant is required to have the relevant expertise, experience, independence and objectivity (adapted from NRA 2005 a and b).

Taking account of the EPA guidelines (2002) a cultural heritage consultant for electricity transmission projects is required to demonstrate:

- A proven record of carrying out robust and transparent heritage impact reports for electricity transmission projects.
- A capability of characterising the existing historic and archaeological environment and evaluating its significance.

- Knowledge of the relevant cultural heritage legislation, standards and guidelines and code of practice and an ability to appropriately incorporate these statutory and non-statutory requirements into the reporting process.
- Familiarity with the criteria for evaluation and classification of significance and impacts.
- An understanding of the design process, construction techniques and types of electricity transmission projects in so far as they are relevant to the cultural heritage environment and to be able to interpret specialised electricity transmission documentation in order to anticipate the affect on cultural heritage features/material during construction and operation phases of the project.
- An ability to consult with and assist the design team and other consultants in the decision making process and in developing mitigation measures for cultural heritage.
- An ability and relevant experience to clearly and comprehensively present and articulate all findings to all stakeholders in a timely manner.
- An ability to concisely and accurately prepare a brief of evidence, present all findings and respond to queries and submissions in a nontechnical manner at oral hearings to the inspector and all interested stakeholders.

An individual cultural heritage consultant may not be qualified or have the relevant experience to conduct all areas of the assessment. Consultants may be required to undertake detailed assessments and surveys for built heritage and archaeological purposes for example, fabric conservation report, structural stability report, historic garden analysis, landscape & geophysical surveys, aerial, metal detection surveys or detailed cultural heritage reports on local folklore in a number of differing environments for example marine, intertidal and bog land.

It is the responsibility of the specialist/consultant to understand the proposed development sufficiently so that likely significant adverse impacts can be anticipated and mitigated where possible (EPA 2002). The Project Manager of each individual scheme must ensure that the team assessing the project has all the required expertise as the project develops.



## 1.4 Description of Typical Electricity Transmission Project Designs

The transmission network in Ireland comprises structures and overhead lines, underground cables and substations. When the need for a new circuit is identified in Ireland, EirGrid will consider all available solutions for the new circuit. This will include overhead line and underground cable solutions, considering both HVAC and HVDC technology, as appropriate. Factors which will influence the solution decision include technical, economic and environmental considerations.

It is important to note that each project is different and EirGrid will review potential solutions on a project-by-project basis. EirGrid will continue to keep technology developments under review and will consider new technologies as appropriate.

In order to inform these Guidelines, the typical technologies and construction techniques used in the transmission system process are summarised.

### 1.4.1 Overhead Lines (OHL)

Transmission lines are generally supported on either wooden pole sets or steel lattice towers (intermediate and angle towers). Angle towers are used where a line changes direction and conductors are held under tension. The type and height of structures required will vary according to the voltage of the overhead line, and the location and type of environment and terrain in which they are placed. Access routes (temporary and permanent) may be constructed for the construction and maintenance of the transmission line.



Example of a newly built access route for a transmission project, Co. Donegal

### 1.4.2 Structure Design

For all new electricity transmission projects, efficient, appropriately placed and optimally designed structures are carefully considered and proposed. The design employed depends on the local environment, topography and technologies involved, and will vary from 110kV, 220kV or 400kV (Appendix 6, Typical Electricity Structures), depending on the specific transmission need identified. The spacing between structures depends on technical limitations and on the topography, particularly to ensure that conductors maintain a specific minimum clearance above the ground at all times.

#### **Steel Lattice Tower Structures:**

The weight of conductors and characteristics of 220 kV and 400 kV lines require that they be supported exclusively on steel lattice structures. These lines can be configured as single circuit or double circuit (two separate circuits supported on a single structure), with double circuit requiring larger towers. Double circuit 110 kV overhead lines also require support of steel lattice towers. The average number of structures on a line is 3-4 per km depending on topography.

**Table 1.1 Key Design Features: Single Circuit 220 kV and 400 kV overhead line support structures**

| <b>Key Design Features</b>             | <b>220 kV Indicative Range</b>   | <b>400 kV Indicative Range</b>   |
|--|--|--|
| Height range                           | Depends on technical details of individual projects but generally between 20-40m | Depends on technical details of individual projects but generally between 20m -52m |
| Maximum range of width at ground level | 6m to 12m  | 7m to 12m  |
| Number of foundations                  | 4  | 4  |
| Average span between towers            | Approx. 320m (dependent on local topography)                                     | Approx. 350 (dependent on local topography)  |



**Example of a typical 400 kV intermediate tower design along the Dunstown-Moneypoint overhead line with a view towards a low visibility ceremonial enclosure (CL042-020), Co Clare**



Example of a typical 220 kV intermediate tower design along the Cashla – Flagford overhead line showing a ringfort (RO022-054064), Co Roscommon

### ***Key Features of single circuit 110 kV overhead lines:***

A 110 kV single circuit overhead line requires that conductors and earth wires are supported on a combination of steel lattice towers and double wood polesets. The average span between these poles for a line of this type is approximately 180m but the actual span achievable depends on local topography.

**Table 1.2 Key Design Features: Single Circuit 110 kV overhead line support structures**

| <b><i>Key Design Features</i></b>   | <b><i>110 kV Indicative Range</i></b>         |
|-------------------------------------|---|
| Height range (double wood polesets) | 16m to 23m (incl. buried depth normally 2.3m) |
| Pole centres                        | 5m  |
| Number of foundations               | 2   |
| Height range (steel angle towers)   | 18m to 24m                                    |
| Maximum width at ground level       | 4m to 9.8m                                    |
| Average span                        | 180m  |



Example of a typical 110kV support structure in the form of double wood polesets (Co Sligo)

#### Double circuit design option (110 kV)



Typical 110 kV double circuit structure in close proximity to an amenity area

Where two single circuit lines are in close proximity or where space is at a premium and subject to technical specification, it may be possible to have the two circuits on one structure.

### 1.4.3 Underground Cabling (UGC)

High voltage (HV) circuits can only be laid underground using special HV cables designed specifically for underground use. The conductors in underground HV cables must be heavily insulated to avoid a short circuit between the conductor and the ground around the cable.

The cable is installed directly into the ground in an excavated trench. Cables are usually laid within existing public roads; however, while it is unusual for a cable to cross private open ground, it can occur on occasion.

The overall installation of a cable route over a large distance is broken down into sections of cable that are connected using a cable joint. Cable joints are installed in joint bays which are typically concrete structures buried underground, occurring generally every 500–700m along an alignment.

Once installed, the road surface is reinstated. Where a cable route is in an open area, it is returned to agricultural/grassland use. Where a cable passes through forested land the route is not replanted with trees to prevent any damage to the cable by tree root growth.

**Table 1.3 Key Design Features: Underground Cabling**

| <b>Key Design Features</b>            | <b>HV Cable (typical dimensions)</b>   |
|---------------------------------------|--|
| Cable Trenches                        | c.0.6m wide-1.25m deep for a 110 kV trench,<br>c. 1.1m wide x 1.25m deep for 220 kV and 400 kV for<br>a single cable |
| Joint Bays                            | 6m long, 2.5m wide and 1.8m deep   |
| Excavation trench for Joint Bay       | 7m long, 3m wide and 2m deep   |
| Average span between joint bays       | 500m–700m  |
| Directional Drill entry and exit pits | 1m x 1m x 2m   |



**Underground cable construction on agricultural land**



**Re-growth following underground cable construction on agricultural land**

#### **1.4.4 Substations**

Substations connect two or more transmission lines; they take the electricity from the transmission lines and transform high to low voltage, or vice versa. They comprise various components including voltage switches, transformers and associated lines and cabling.

The siting of a substation depends on topography; the ground must be suitable to meet technical standards. With regard to earthing requirements and soil stability, substations are usually constructed on reasonably level ground, in areas that are not liable to flooding or crossed by significant watercourses. A substation site is normally future proofed with the capability to be extended if the need arises.



**Srananagh 220kV/110kV substation, Co Sligo, example of a typical AIS substation**

Substations can take two forms:

An Air Insulated Switchgear (AIS) substation is where the electrical equipment infrastructure is primarily installed outdoors, with the use of natural air as an insulation between circuits. This option requires a relatively large compound footprint.

A Gas Insulated Switchgear (GIS) substation, is where gas (Sulphur Hexafluoride – SF<sub>6</sub>) is used as the insulation between circuits. This requires the electrical equipment to be contained internally, in buildings of some 11–13m over ground. This allows for a significantly smaller substation footprint.

Both options require the associated provision of access roads off and onto the public road network and the provision of associated electrical equipment and infrastructure (including underground cables), as well as ancillary waste water treatment facilities and other site development and landscaping works.



Example of a typical GIS substation, Co Limerick



## **2 Potential Impacts of High Voltage Transmission Projects on Cultural Heritage Assets**

### **2.1 Introduction**

The process of routing electricity transmission projects is a complex one that must achieve a balance between technical and other engineering requirements, economic feasibility, environmental and cultural heritage factors. Given the linear extent of electricity transmission projects routed through all terrains and varied landscapes, they have the potential to impact upon the cultural heritage environment of the area they travel through. Careful integrated routing and substation site selection processes, and appropriate mitigation measures can address potential impacts.

Transmission route planning typically aims to avoid heavily populated areas (on the grounds of potential visual and amenity impact); however in order to provide distance from population centres, transmission projects may be located in more remote areas where there is a greater potential to reveal previously unidentified heritage assets and their natural attributes. This creates the potential to bring the location and siting of projects into direct conflict with archaeological and historic environments (Appendix 4 provides a non-exhaustive range of heritage assets, environments, landscapes and site types).

Assessment of potential impacts must include the implications of the development on their setting, and should embrace both the direct physical impact of developments and any indirect impacts that may arise as a consequence of construction or operation of a proposed transmission development.

### **2.2 Types of Impact**

When designing an electricity transmission project, consideration must be given to the potential impacts of the proposed development including on the historic environment. This consideration extends to designated and significant undesignated sites and areas, for example areas of archaeological potential or unrecorded designed or cultural heritage landscapes (e.g. pre-famine clachans), and embraces both direct, physical impacts and indirect impacts (Appendices 2 and 4).

The potential impacts of transmission projects on cultural heritage assets may relate to the construction and operation of substations and to the connection to the electrical grid by OHLs via wooden polesets, steel lattice towers, or by underground cable. In order to assess the likely significant impact of transmission line infrastructure on cultural heritage assets, the cultural heritage consultant must understand the characteristics and various components of a transmission line technology during the construction and operation phase.

Every landscape presents different topographical and environmental conditions, land cover and land usage and as such the location, scale and physical form of each element of high voltage transmission projects and associated structures are site specific. As a consequence, the range of potential impacts depends on the individual circumstances of each scheme.

Impacts can be direct, indirect or cumulative. The methodology used to assess the type and level of impact assessment in the Guidelines is devised in accordance with the EPA Guidelines (2002) (Appendix 2).

### Direct Impact

A direct impact occurs where a development is partly or wholly located at a cultural heritage asset and entails the removal of part of, or the entire, asset. The routing of OHL and siting of substations can also have a direct impact on the immediate setting and amenity of cultural heritage assets.

### Indirect Impact

Indirect impacts can occur due to the close proximity of transmission structures, OHLs and substations to a cultural heritage asset. Such impacts may include the degradation of setting and amenity of a heritage asset, or may cause the severance/fragmentation of associated features. The location of structures can provide a visual intrusion which can detract from established historic views and can disrupt the inter-visibility between heritage assets.

### Cumulative Impact

A cumulative impact is one where there is an addition of many small impacts. This might occur for example where impacts arise from other significant existing infrastructure or for example where a substation is upgraded to include connection to further transmission lines. Excessive wirescape from merging schemes in the vicinity of a substation can detract from views and the setting/curtilage of a cultural heritage asset.

### ***Examples of potential direct and indirect cultural heritage impacts associated with the construction and operation of electricity transmission structures***

- The removal or part removal of a heritage asset due to construction activities.
- Ground disturbance and excavation, caused by construction activities, which may lead to the damage or destruction/removal of recorded and previously unknown heritage assets.
- The routing of an overhead transmission line can indirectly adversely affect the setting of a heritage asset.
- The location of towers can provide a visual intrusion which can detract from established historic views and can disrupt the inter-visibility between heritage assets.
- Degradation of the setting and amenity of a monument, protected structure or feature of cultural or architectural heritage merit, or cause the severance/ fragmentation of interrelated features.

This impact categorisation was used to assess the impact of transmission projects on cultural heritage during the site survey for the EirGrid Cultural Heritage Evidence Based Study (EirGrid 2014). A sample of the results and findings of this study are included as illustrative examples in this section.

The following illustrative examples of the various types of transmission scheme impacts on cultural heritage assets were undertaken prior to the adoption of the European EIA Directive, associated Irish legislation relating to EIA, and development of the EIA process. These impacts occurred at a time when there was no focus on protecting cultural heritage assets, but which would now be deemed as significant impacts.

For all more recent, current and future transmission infrastructure developed with good routing practices, well designed EIA processes, statutory protection and consultation with the regulatory authorities, it is likely that these types of impacts would be avoided.

### Examples of Direct Impact



This 220kV intermediate tower is located on the outer bank of a ring barrow (DU021-039). It has a significant direct impact on the monument and setting. (Carrickmines – Maynooth 220 kV, Co. Dublin)



This structure and OHL has a direct and significant impact on the setting of this stone circle (CO059-011). Clashavoon-Tarbert 220kV, Co. Cork

## 2.3 Potential Impact on Setting (direct and indirect impacts)

All cultural heritage assets have a setting or surrounding in which the asset is experienced. The extent of the setting can be its immediate environment or can extend far beyond its physical extent. Setting does not have a fixed boundary and cannot be definitively described as a spatially bounded area or as lying within a set distance of a heritage asset. Some settings can be well defined and easily understood, for example a designed landscape setting such as Powerscourt House, Co. Wicklow, created to appreciate a framed vista towards the Sugar Loaf Mountain. Equally, setting can be associated with the history and character of a place rather than simply views; for example an historic battle, such as the Battle of the Boyne, Co. Meath leaves little visible trace, but the location includes strategic placements and routes used by the opposing sides and historic associations with topographical features in the landscape.

While subsurface archaeological sites may not be readily accessible, they too can have a setting that contributes to their significance. This setting may include an important topographical context (or landform e.g. hilltops, watercourses, sheltered aspects), strategic views or a line of sight to other sites etc. and may extend outside the site's immediate area.

Most settings have also experienced change and have been altered over time and settings can have either a positive or negative contribution to the significance of an asset or may be neutral. While change within the setting of historic sites may often be acceptable, in certain instances development will be considered inappropriate as not all settings have the same capacity to accommodate change without harm to the significance of the heritage asset, or the ability to appreciate that significance. This capacity to absorb change depends on a number of factors and as a result the setting of heritage assets needs to be considered on a case by case basis. How people enjoy the heritage asset is also an important aspect of setting.

Underground cabling does not generally result in an impact on setting as it is generally run through road surfaces, while in open areas they are reinstated after construction. The impact of cabling on the setting of cultural heritage assets is generally temporary, lasting only for the duration of the construction works and reinstatement period. In general, therefore, the most likely potential impact from UGC development will be a direct impact upon subterranean features.

Assessments of effects on cultural heritage assets should also include consideration of effects on documented wider cultural heritage landscapes within which those resources are located. The planning and design of a transmission project can play a vital role in maintaining a site's setting.

## 2.4 Assessment of Setting

Setting is a critical issue in relation to the planning and development of transmission line infrastructure and potential impacts on the cultural heritage environment. Overhead transmission lines comprise large upright structures and linear features across the landscape. Their scale relative to features in close proximity such as monuments or historical structures can have a visual intrusion on the landscape. While direct physical impact can easily be assessed in quantitative terms, the assessment of setting can be subjective and as such is a matter of qualitative and professional judgement.

The scale, form and layout of an electricity transmission development, therefore, requires a collaborative and iterative design development process with designers, archaeologists and landscape and visual specialists engaged in the process from the outset.

English Heritage (now Historic England) has developed best practice guidance<sup>9</sup> in relation to assessment of development proposals on setting. This guidance can be used as a baseline document to assist in the assessment of setting of heritage assets in Ireland. The aim of the guidance is to assist effective and timely decision-making by ensuring it takes place within a clear framework and is as transparent and consistent as possible. The guidance is reflected in the following 5-step assessment:

#### ASSESSMENT OF DEVELOPMENT PROPOSALS ON SETTING

- identify which heritage assets and their settings are affected;
- assess whether, how and to what degree these settings make a contribution to the significance of the heritage asset(s);
- assess the effects of the proposed development – direct, indirect, cumulative;
- explore mitigation measures;
- make and document the decision and monitor outcomes (outside the scope of impact assessment).

The starting point is to establish the heritage assets that are likely to be affected by the development proposal. The assets to be assessed will depend on the nature and scale of transmission infrastructure proposed and the landscape through which it runs. Consultation with the landscape and visual consultants will assist in identifying an area around the proposed development within which it is reasonable to consider setting effects. Not all heritage assets will be impacted in the same way, some will be more sensitive to change affecting their setting than others.

The next step is to assess whether, how and to what degree the setting of the heritage asset(s) makes a contribution to the significance of the asset. The setting attributes of a heritage asset can incorporate its physical surroundings, its relationship with other heritage assets, the way the asset is appreciated and its associations and patterns of use. The following non-exhaustive list of potential attributes/factors (Table 2.1) as recommended by Historic England can be used as a guide to establish this:

---

<sup>9</sup> *The setting of heritage assets* (2011) superseded by *Historic Environment Good Practice Advice in Planning Note 3: The Setting of Heritage Assets*, (March 2015) (English Heritage now Historic England)

**Table 2.1 Checklist for Assessing the Contribution of Setting to the Significance of a Heritage Asset (after English Heritage 2011)**

| <b>CHECKLIST OF POTENTIAL ATTRIBUTES OF A SETTING OF A HERITAGE ASSET</b>                            |
|--|
| <b>Physical surrounding of the asset (evidential and historic values)</b>                            |
| Topography   |
| Other heritage assets (including buildings, structures, landscapes, areas or archaeological remains) |
| Definition, scale and 'grain' of surrounding streetscape, landscape and spaces                       |
| Formal design  |
| Land use   |
| Green space, trees and vegetation  |
| Openness, enclosure and boundaries   |
| Function relationships (inter-relationship with other sites)   |
| Degree of change over time   |
| Integrity (intactness)   |
| Issues such as soil chemistry and hydrology  |
| <b>Experience of the asset (aesthetic values)</b>  |
| Surrounding landscape or townscape character   |
| Views from, towards, through, across and including the asset   |
| Visual dominance, prominence or role as focal point  |
| Intentional inter-visibility with other historic and natural features                                |
| Noise, vibration and other pollutants or nuisances   |
| Tranquillity, remoteness and 'wildness'  |
| Sense of enclosure, seclusion, intimacy or privacy   |
| Dynamism and activity  |
| Accessibility, permeability and patterns of movement   |
| Degree of interpretation or promotion to the public  |
| The rarity of comparable survivals of setting  |
| <b>Associative Attributes of the asset (communal heritage value)</b>                                 |
| Associative relationships between heritage assets  |
| Trails, visitor amenity areas and guided sites   |
| Cultural associations  |
| Celebrated artistic representations  |
| Traditions   |

**CHECKLIST OF POTENTIAL ATTRIBUTES OF A SETTING OF A HERITAGE ASSET**

An example of setting narrative:

Setting:

*The moated site is a recorded monument located in improved pasture on an E facing slope. It has a densely overgrown northern perimeter, and its western edge is incorporated to a field boundary. The field immediately surrounding the site contains evidence of associated field systems which can be seen as soil marks in aerial photography and stray finds have been identified during ploughing in the field. The overgrown nature of the site provides limited views to the N and W, any former sightlines that the site would have had in the surrounding landscape are no longer legible. There is another overgrown moated site 1.3km the SE of the site on the E side of the river and both sites are likely to have been related and are inter-visible.*

Degree to which the setting contributes to its significance:

*The moated site was intentionally designed to take advantage of the proximity of the river to the E, and this relationship is still intelligible in the landscape. The fields that immediately surrounding the site that may contain potential associated field systems and the potential link and visual relationship to the moated site to the SE are important aspects to the setting of the site which contributes to its significance.*

The setting of heritage assets should be regarded at the earliest stages of transmission design. At the route corridor identification stage the criteria (evidential, historic, aesthetic and communal heritage values) described in Table 2.1 can be reviewed to assist in characterising the general historic landscape and the sensitivity of heritage assets within a landscape. Emerging areas of heritage potential can then be visited in the field for further assessment.

At the EIS/ER stage of a project, when the location and design details of the transmission project are known, an impact assessment on the setting of the individual assets can take place. A checklist devised by English Heritage will assist in defining the type and significance of the potential impact on the heritage asset (Table 2.2). The checklist is devised to be used in conjunction with the project specific field recording form (Appendix 5 EirGrid Recording Form) at the EIS/ER stage of a project.

**Table 2.2 Checklist for Assessing Impact on Cultural Heritage Assets (adapted from English Heritage for transmission projects)**

| <b>Impact on Setting Checklist</b>                     |   |
|--|---|
| <b>Location and Siting of the transmission project</b> |   |
| <input type="checkbox"/>                               | Location of structures in relation to the heritage asset (N, S, E, W)                   |
| <input type="checkbox"/>                               | Orientation of the overhead transmission line in relation to the asset                  |
| <input type="checkbox"/>                               | Proximity to/from asset (i.e. to the structure, OHL, substation etc.)                   |
| <input type="checkbox"/>                               | Extent of the infrastructure  |
| <input type="checkbox"/>                               | Position in relation to landform (e.g. in a valley, on a hilltop, at the edge of field) |
| <input type="checkbox"/>                               | Degree to which location will physically or visually isolate asset                      |
| <input type="checkbox"/>                               | Cumulative (e.g. wirescape or other developments)                                       |
| <input type="checkbox"/>                               | Position in relation to key views associated with the heritage asset                    |
| <b>Form and Appearance of the transmission project</b> |   |
| <input type="checkbox"/>                               | Prominence, dominance or conspicuousness  |
| <input type="checkbox"/>                               | Competition with or distraction from the asset  |
| <input type="checkbox"/>                               | Dimension, scale and massing  |
| <input type="checkbox"/>                               | Proportions   |
| <input type="checkbox"/>                               | Visual permeability (extent to which it can be seen through)                            |
| <input type="checkbox"/>                               | Materials (texture, colour, reflectiveness)   |
| <input type="checkbox"/>                               | Structure / substation design   |
| <input type="checkbox"/>                               | Diurnal or seasonal change (e.g. night-time appearance/ vegetation cover)               |
| <b>Other Effects</b>                                   |   |
| <input type="checkbox"/>                               | Change to built surroundings and spaces   |
| <input type="checkbox"/>                               | Change to skyline   |
| <input type="checkbox"/>                               | Change to general character   |
| <input type="checkbox"/>                               | Changes to public access, use of amenity  |
| <input type="checkbox"/>                               | Changes to land use, land cover, tree cover   |
| <input type="checkbox"/>                               | Changes to archaeological context, soil chemistry or hydrology                          |
| <input type="checkbox"/>                               | Changes to communications/ accessibility/permeability                                   |
| <b>Setting Assessment</b>                              |   |
| <input type="checkbox"/>                               | Asset Type and Ref No.:   |
| <input type="checkbox"/>                               | Cultural Heritage Asset Status:   |
| <input type="checkbox"/>                               | Impacted by:  |
| <b>Impact on Setting – Comment Box</b>                 |   |
|  |   |
| <b>Compiled by:</b>                                    | <b>Date:</b>  |



Once the impacts are known the final stage of the assessment of setting is the exploration of appropriate mitigation measures.

## 2.5 Summary of Setting

The assessment of setting is concerned with an understanding and appreciation of the cultural heritage asset and its significance. In accordance with accepted guidance, setting is not exclusively about the visual envelope, it embraces considerably more than just views. An impact on setting will only occur if the change affects the contribution made by setting to the significance of that asset.

Consideration of setting of a cultural heritage asset is a matter of informed professional judgement and should be:

- determined on a case by case basis and where necessary in consultation with landscape architects and other relevant disciplines
- dependant on landscape and topography

The approach to setting for impact assessment is dependent on:

- A set of pre-defined descriptive value attributes to ensure objectivity (Table 2.1)
- A field survey checklist to ensure consistency (Table 2.2 and Appendix 5)
- Field & site survey to describe the receiving existing environment and the capacity to absorb change (Appendix 5 Field Recording Form)
- A knowledge of the proposed development details

The following are illustrated examples of the various type of transmission scheme impacts on the setting of cultural heritage assets. Again, these occurred prior to the original EIA Directive in 1985, and prior to real widespread understanding or appreciation of, the importance of the cultural heritage.

For all more recent and future transmission infrastructure developed with good routing practices, and well-designed EIA processes, it is likely that these types of impacts would be avoided.

### Examples of Impacts on Setting

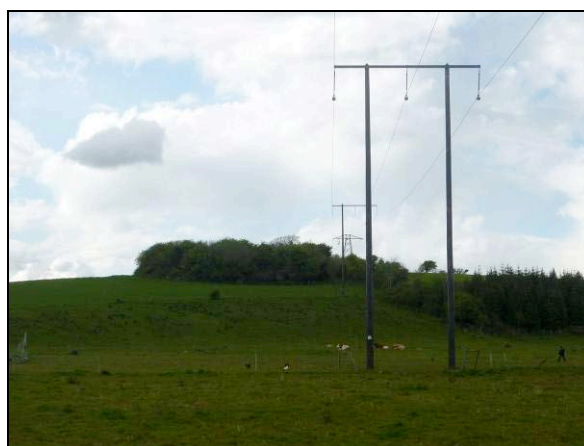
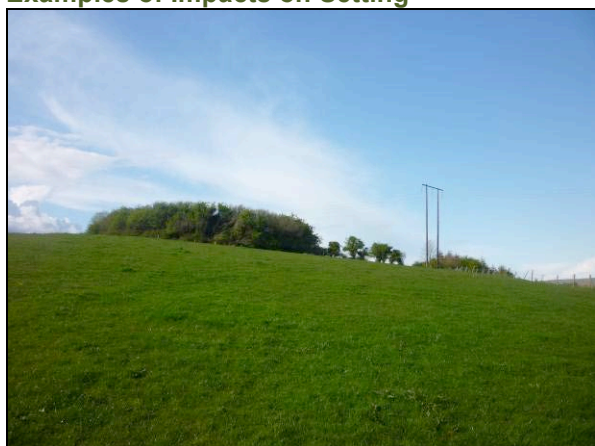

#### 110 kV Castlebar – Cloon showing a ringfort (MA090-008) in the middle ground, Co Mayo

A transmission project may have no physical impact to a monument but may impact the setting, in this case a prominent large scale earthwork (ringfort), placed on the crest of linear ridge. Routing and line design should consider whether structures may inadvertently isolate an upstanding monument from other highly-visible monuments in the area and disrupt the inter-visibility to and from other ringforts placed on this ridge.



**Church & CBG (OF013-007001/002) in the middle ground, Co Offaly located in between transmission structures**

The sensitivity of an asset's setting to change is not dependent on the proximity of the development and interrupted views alone; other attributes such as quiet, tranquillity or remoteness may be essential and contribute to the significance of a heritage asset. For example, the solitude and experience of this church and children's burial ground (in the middle ground and located between a 110 kV and 220 kV structure) is disturbed /impacted to a greater extent by the noise of the neighbouring Bord na Mona development (screened by and located to the rear of the conifer trees).



**The 220 kV Cashla – Flagford overhead line (Co Roscommon), crosses the archaeological landscape of Rathcroghan (RO022-057--), the royal seat of the kings of Connaught.** The photograph shows the location of a souterrain, enclosure and ancient road. Careful route planning should avoid potential or actual impact on a recognised archaeological landscape

## 2.6 Cumulative Impacts

Where there are also impacts arising from other significant existing infrastructure or a merging of impacts there can be a cumulative impact as demonstrated in the examples below.

### Examples of cumulative impacts



**A ringfort (CL067-040) site situated in a former demesne landscape.**  
The 220 kV structure is located 32m to the south west of the ringfort and the 400 kV structure is located approximately 12m from the monument. There is a significant impact on the immediate setting and potential subsurface features associated with the monument. The transmission lines have a significant impact on the setting of the monument and on relict features associated with the former demesne



**An aerial image of the above lines feeding into the substation.**  
There is a significant impact on the immediate setting of the monument. The entire area has been subject to substantial change with the development of the substations. The previous historic demesne setting has been removed by forestry and development. 400 kV Dunstown – Moneypoint and 220 kV Moneypoint – Prospect, Co Clare.



**110 kV Lanesboro – Mullingar (WM 018-030), Co Westmeath.**

This 110 kV pole set has a direct significant impact on this ringfort site – there is also a cumulative impact of a low voltage distribution line and additional impacts from other sources.

## 2.7 Construction Impacts

The construction of transmission projects involves both temporary and permanent impacts. Permanent impacts exist as long as the line is in place, and temporary impacts occur during construction or during maintenance and uprating works.

For transmission circuits, the extent of the land disturbed during construction is greater than that during site operation when disturbance caused by construction has been reinstated. The following are key components in the construction of a high voltage electricity transmission project:

- I. Overhead transmission line construction:
  - the construction of temporary and permanent access roads (where required)
  - the installation of structure foundations for steel lattice towers (angle towers for all high voltage projects and intermediate towers for 220 kV and 400 kV and double circuit 110 kV)
  - the installation of wood poles for 110 kV projects
  - the stringing of conductors and the reinstatement of temporary access
  
- II. Construction of Substations:
  - clearance of a large area of land
  - excavations
  - ancillary waste water treatment facilities
  - landscaping works
  - permanent and temporary access ways
  
- III. Underground cabling:
  - topsoil stripping of wayleave corridor
  - linear trenching of route
  - construction compound facilities

## I. Overhead Transmission Line Construction (OHL)

### Access Tracks and Haul Roads



**Example of a temporary access road over soft ground using aluminium panels**



**Example of a crushed stone access road installed to avoid undesignated farmstead in ruin**

Access is required to every structure location for foundation excavation, concrete delivery and for a crane or a gin-pole (or similar machinery) to erect towers. In poor ground conditions e.g. bog or wet land, bog mats or temporary wooden matting is laid. In more stable conditions crushed stone roads are used. The access area required for angle towers is greater than that for intermediate structures, as access and space is required for conductor drums and large winches. Excavators are generally of the tracked type to reduce likely damage to and compaction of the ground.

The location of access roads are subject to consideration of environmental constraints, and as a result the most direct access route to a structure installation may not be appropriate. It is necessary to ensure that the preferred/chosen access route does not impact or affect a cultural heritage feature. Where there is a known monument or a potential to reveal cultural heritage features the route will require archaeological monitoring during the construction process. Good communication between the Project Manager and the onsite archaeologist is essential throughout the construction period.

## Lattice Steel Tower Structures

Concrete foundations are required for tower bases. It is usual to excavate four foundation blocks. The foundation size and type is dependent on ground conditions and structure type. Depending on the ground conditions, larger block foundations are required and sometimes the use of precast concrete piles is required.



Typical foundation footings Carrickmines – Maynooth 220 kV, Co. Dublin

Donegal 110kV Project Sheet Piling used in poor ground for angle mast foundation pit courtesy of Byrne Mullins & Associates



Typical Angle Tower (110 kV) and structure foundation designed in response to a wetland environment

Galvanised steel lattice structures are used as standard practice where there is a change in overhead line direction on a 110kV OHL. These structures typically range in height from 17-24m depending on the wire span and terrain. Larger steel structures may be required on 220kV and 400kV OHL.

## Wooden Polesets

The excavation required for each pole is typically 1.5m-2m x 3m x 2.3m deep. No concrete foundations are required for polesets in normal ground conditions, and installation time is approximately two per day.



Example of 110 kV wooden polesets



Trench for pole and sleepers used to stabilise pole

## Stay Lines

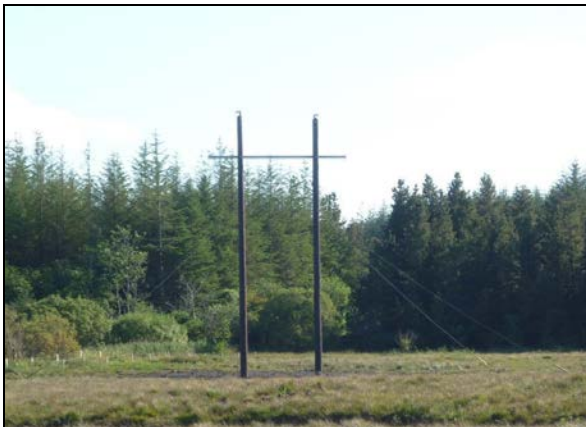

Typical 110 kV poleset with stay lines



Stay rod trench

Where ground conditions dictate, stay lines may be required. Stay lines provide additional stability for the poleset. They are usually used in bogland conditions. They would generally require four trenches (2m x 2m x 1.8–2m deep) excavated at an appropriate distance from the pole-set.



### Earth Ring or Mat



For all transmission lines with earth wires, there is a requirement to install an earth ring or mat in the ground around the base of the structure of both towers and polesets.

### Braced 110 kV Poleset



Typical 110 kV steel braced poleset

Braced polesets are similar to intermediate polesets, however they are braced internally for additional strength along their centre and on the earthwire section using steel channels. Braced polesets can be used to support circuits through a change in line direction of less than 20 degrees, subject to suitable ground conditions. The average foundation size for a braced poleset is 9.3m x 3.1m x 3.2m deep.

## Stringing of Conductors



### Stringing of a 110 kV earthwire line.

Once the structures have been erected the conductors are winched to/pulled from section/angle towers. Once angle towers are erected, conductor stringing can commence, installing conductors from angle tower to angle tower via the line intermediate structures. Conductor drums are set up at one end of a straight (the alignment between angles) with special conductor stringing equipment and pulled from one end to the other.

The final stage is to reinstate the area around the structures to its original condition and to remove temporary access roads.

### Likely potential impact of OHL construction (assuming avoidance of known cultural heritage features and their settings)

Ground excavation for the foundations of structures and associated works such as road/track construction, stay wires and earth rings/mats has the potential to negatively impact recorded and unrecorded, low visibility and buried heritage assets. Access routes may also be constructed in close proximity to a heritage asset causing a temporary impact prior to reinstatement.

While the construction of transmission projects has the potential to damage previously undiscovered archaeological remains, ground disturbance associated with the overall footprint of an overhead line (steel lattice tower, angle tower and/or double wooden poleset) is very limited, when compared with other more conventional forms of development. Furthermore, flexibility in the siting of individual structures affords significant opportunity to avoid a direct impact.

### Actual impacts of OHL construction

The Cultural Heritage Evidence Based Study has shown that archaeological monitoring and test excavation of structures (polesets, towers and angle towers) along OHL is documented on 34 separate occasions in the archaeological record from 1970- 2010. To date no large sites or extensive in-situ deposits have been revealed as a result of these investigations. Archaeological features were recorded on four occasions. The sites/features discovered comprised burnt spread/ fulacht fiadh material, and a stray artefact find. During the monitoring of schemes previously unrecorded sites were identified in proximity to the transmission projects. These sites included a barrow site, a stone structure, a lime kiln and a midden, and were recorded and avoided by the transmission development.

Table 2.3 summarises potential construction impacts of OHL.

## II. Underground Cables (UGC)

**Construction:** Underground Cables (UGC) require substantial earthworks along the cable trench and intermittent machinery access routes. Ground disturbance extends along the entire length of the cable route. Works include the clearance of all vegetation and boundaries and the trenching of the entire route (ranging from c.0.6m wide-1.25m deep for a 110 kV trench and c. 1.1m wide x 1.25m deep for 220 kV and 400 kV for a single cable), the removal of excavated material and backfilling. The extent of the trench will vary according to the number of cables. Cable joint bays (construction areas needed to connect fixed length cables), which are wider than the cable trenches have to be constructed at intervals (500–700m) along the length of the cable route.

Where trenching is not possible, for example in an area of particular sensitivity such as watercourses, in some instances directional drilling (a trenchless method of installing the UGC) is also used. It requires the excavation of temporary launch and reception pit and the cable is then constructed below the sensitive environmental zone.

Where the cable crosses a bridge or culvert the preferred option is to install the cable in the road structure above the key stone/ bridge deck. If there is insufficient depth options can include the attachment of the cable to the side of the bridge, the construction of a new cable bridge, or to install the cables in the land adjacent to the bridge or road.



**Cable trench linking substation to converter station (400 kV), East West Interconnector Project. Courtesy of Byrne Mullins & Associates**



**Cable Joint Bay, East West Interconnector DC UGC Project. Courtesy of Byrne Mullins & Associates**

### Likely potential impact of UGC construction

Assuming the avoidance of known cultural heritage features and their settings, the ground excavation and trenching activities for UGC can potentially lead to interference, damage, or destruction/removal of recorded and previously unknown subsurface archaeological monuments and remains and historic building foundations. The impact of cabling on the setting of cultural heritage assets is temporary, lasting only for the duration of the construction works and reinstatement period.

### Actual impacts of UGC Construction

The construction of UGC has a considerably higher potential to unearth buried archaeological sites, features and artefacts than the construction of OHL tower foundations. UGC requires the entire construction wayleave corridor to be cleared and as such there a significant potential for UGC to lead to the destruction/removal of recorded and previously unknown archaeological monuments and remains.

This is demonstrated in the EirGrid Cultural Heritage Evidence Based Study where between 1970-2010 twenty archaeological licences associated with UGC construction were recorded as being issued. Thirteen archaeological sites or features were identified. The sites comprised ephemeral features such as burnt spreads and linear features such as boundaries and culverts but significantly they also revealed disarticulated skeletal remains, individual burials and at least four cemetery sites. Such a scenario is mitigated by full excavation or redesign and is decided by the statutory authorities.

Table 2.3 summarises potential construction impacts of UGC.

## III Substations

**Construction:** The land area required for a substation is dependent upon the space required for the line termination towers and the type of switchgear to be installed. Gas Insulated Switchgear (GIS) requires less space than Air Insulated Switchgear (AIS). Building the substation requires heavy construction plant as well as large and heavy electrical equipment. A permanent access road is also required.

### Likely potential impact

Assuming the avoidance of known cultural heritage features, the effects of substation construction on the historic environment relate specifically to the potential for ground excavation and construction activities to lead to the interference, damage or destruction of recorded and previously unknown heritage assets.

Depending upon the siting of a substation, its operation and presence could potentially have adverse effects on the setting of heritage assets. The significance of the effects on the historic environment depends on the monument/building type, extent of development and potential for screening and mitigation measures.

### Actual impacts of Substation Construction

Substation sites are sited to avoid direct impact on known archaeological sites or areas of archaeological or cultural heritage potential. There is however potential that previously unknown archaeological features will be identified during topsoil stripping of the site. The EirGrid Cultural Heritage Evidence Based Study has shown that in the last 12 years twenty-five archaeological licences were issued for substation construction, of which four revealed archaeological sites. The sites that were revealed and fully excavated were small in scale comprising fulacht fiadh, a charcoal spread and a kiln site and a charcoal spread and group of pits.

Table 2.3 summarises potential construction and operational impacts of substations.



**Ballynahulla (also known as the East Kerry North West Cork) Project General View Ground Preparation Works for Substation courtesy of Byrne Mullins & Associates**

## 2.8 Operational Impacts

The potential disturbance of heritage assets due to the development of a transmission project is mostly restricted to the construction period.

Operational activities mainly comprise maintenance activities which may require vehicular access; however the impact risk on known upstanding cultural heritage sites is considered to be low.

During a line uprate or refurbishment, additional excavation may be required particularly where angle structures require replacement. While these are generally replaced within the footprint of the original structures there could be some potential for damage in and around the working area in sensitive cultural heritage locations.

During UGC maintenance and repair, work is carried out as much as possible in the cable joint bay locations, cable routes are re-opened only when there is an incident on the line or a need to undertake a cable patrol. Maintenance of substations are generally carried out within the footprint of the substation only and all archaeological issues regarding the substation site will have been resolved during the construction phase.

Table 2.3 summarises potential operational impacts for the various types of transmission infrastructure.

## 2.9 Summary of Potential Impacts

It is widely accepted, and confirmed by the findings of the Evidence Based Study for High Voltage Electricity Transmission Projects in Ireland – Cultural Heritage (EirGrid 2014) that a large number of potential direct and indirect impacts on archaeological monuments and historic landscapes can be avoided through good routing practices. However to facilitate the identification and avoidance of such assets, early consultation with the relevant statutory and non-statutory stakeholders and the completion of robust constraints, route selection studies and EIS reports is required; this must be supported by the necessary field survey and investigatory work, which are important for the early identification of features and areas of significance. These elements are discussed in Sections 4, 5 and 6 of the guidelines.

The above Study found that individual designated monuments and protected structures, NIAH structures and historic gardens, and historic landscapes tend to be limited in physical extent, and therefore not particularly onerous for transmission infrastructure to avoid, and have generally been avoided in the past. Significant but undesignated archaeological sites, buildings and designed landscapes also generally tend to be limited in extent and can most often be avoided.

The practice of placing structures at a field boundary or corner of a field was observed. This has typically occurred in order to facilitate the landowner in carrying out normal farming activities without having to manoeuvre around a structure, and to prevent loss of crop and growing space. It also has the inadvertent benefit of being typically at some remove from a cultural heritage asset and ensures in the majority of cases that the transmission project was at a distance and well screened from the recorded feature. However, when there was a heritage asset adjacent to a field boundary this had an adverse effect and increased the impact.

The practice of placing UGC within existing public roads also has the benefit of locating the circuit in previously disturbed land where the archaeological potential is minimised.

The identification of potential impacts at the earliest opportunity allows for an evaluation of cultural heritage concerns to be properly addressed and integrated into the planning system. This procedure also reduces or avoids the negative impacts of the final route on the receiving heritage environment.

**Table 2.3** shows the various types of transmission infrastructure and potential effects on heritage assets (in the absence of mitigation). Impacts are presented in terms of the development phase of the project, the type, extent and duration of the impact. Some potential direct impacts, particularly on previously unknown subsurface archaeology are limited to the construction phase when intrusive ground works take place.

**Table 2.3 Summary of Potential Construction and Operational Impacts**

| Effect                             | Development Phase            | Direct/Indirect | Duration  | Extent  |
|------------------------------------|------------------------------|-----------------|-----------|---|
| <b>Substation</b>                  |                              |                 |           |   |
| <b>Impact on heritage asset</b>    | Construction and Operational | Direct          | Permanent | Substation area and access road   |
|                                    |                              | Indirect/Direct | Permanent | Setting of archaeological monuments, historic demesnes, protected structures and/or ACAs                      |
| <b>Cabling (trenching)</b>         |                              |                 |           |   |
| <b>Impact on heritage asset</b>    | Construction                 | Direct          | Permanent | Cable trench & wayleave corridor  |
|                                    |                              | Indirect        | Temporary | Setting impacted during construction works, until reinstatement measures have been carried out                |
| <b>Overhead Transmission Lines</b> |                              |                 |           |   |
| <b>Impact on heritage asset</b>    | Construction and Operational | Direct          | Permanent | Structure footprint. Setting of archaeological monuments, historic demesnes, protected structures and/or ACAs |
|                                    |                              | Indirect        | Permanent | Setting of archaeological monuments, historic demesnes, protected structures and/or ACAs                      |

**Successful Transmission Projects depend on:**

- Early and appropriate consultation and dialogue with prescribed authorities and stakeholders.
- Robust and transparent cultural heritage reporting throughout the planning stages – constraints, route selection and environmental assessment.
- Early and open community involvement in the identification and reporting of non-designated assets (intangible heritage).
- Cross referencing of cultural heritage, landscape, and visual impacts, and discussion between environmental consultants.
- Full consideration of all potential options, if necessary informed by archaeological assessment/evaluation and architectural heritage survey.
- Good proportionate decisions on often competing values and interests, for example visual amenity verses impact on buried archaeology.



Where impacts are unavoidable, a variety of mitigation measures can be introduced to reduce, remedy and ameliorate the impact. The most appropriate measures in line with best practice will be undertaken/implemented following consultation with the cultural heritage consultant, and agreement with the statutory authorities.



**Doonagurroge Castle, Co Clare, a recorded monument and protected structure with a nearby double circuit 400 kV line**

## PART II PLANNING AND GUIDANCE

### 3. THE PLANNING OF ELECTRICAL TRANSMISSION PROJECTS AND GUIDANCE ON CULTURAL HERITAGE ASSETS AT EACH STAGE OF IMPACT ASSESSMENT

#### 3.1 Planning and Design Procedures

Guidance on how to approach the planning and implementation of a cultural heritage impact assessment for high voltage transmission projects is provided in this section of the document. The principles of avoidance by design or preservation *in-situ* and mitigation (DAHGI 1999, 33) are central to the cultural heritage ER/ EIA process, and guide the planning and design of transmission projects.

The approach to cultural heritage impact assessment consists of a qualitative and quantitative approach that is based on professional judgement while referencing the EPA Guidelines (2002). The early consideration of cultural heritage impacts in evaluating options assists in the identification and avoidance of key potential issues.

Environmental Impact Assessment (EIA) is a critical tool in managing and clarifying the complex interrelationship and significant impacts between development and the environment. The EIA Directive (Council Directive 85/337/EEC as amended by Directive 97/11/EC, Directive 2003/35/EC and 2009/31/EC)<sup>10</sup> is designed to ensure that projects likely to have significant effects on the environment are subject to a comprehensive assessment. A formal EIS shall be prepared in accordance with the requirements of Article 3 of the EIA Directive. Schedule 6 of the Planning and Development Regulations 2001 specifies the information to be contained in an EIS.

Implementation of the EU Directive on EIA must occur in an open transparent way, with the public and bodies with specific environmental responsibility being given an opportunity to comment and participate in the process of assessment (Article 6 of the EU Directive). The concerned public must also be given an opportunity to challenge the substantive and procedural legality of the final decision (Article 10a of the EU Directive).

Irish legislation, which implements the EU EIA Directive, addresses the possible need for EIA below the mandatory thresholds. There is a requirement to carry out EIA where the competent/consent authority considers that a development would be likely to have significant effects on the environment.

Even where an EIS or 'sub threshold' EIS is not required by a competent authority in respect of a project, that project should still be subject to a comprehensive environmental appraisal, including cultural heritage assessment.

Permission for high voltage transmission projects is sought on a project by project basis. The major projects are primarily determined by An Bord Pleanála as Strategic Infrastructure Development (SID) having regard to development management considerations, including:

- conformity with the applicable provisions of the relevant Development Plans,
- input from Prescribed Bodies and the relevant Statutory Authorities,

---

<sup>10</sup> Directive 2011/92/EU codified Directive 85/337 and its three amendments. Directive 2011/92/EU has since been amended by Directive 2014/52/EU

- requirements to protect areas on account of their ecological, cultural, archaeological, visual sensitivity or significance,
- having regard to strategic directives and development policies,
- The proper planning and sustainable development of the area.

Under the terms of Strategic Infrastructure legislation, inserted into the Planning and Development Acts and associated Regulations, the National Monuments Service (NMS) will make submissions or observations to the Strategic Infrastructure Division of An Bord Pleanála with regard to any potential impact on archaeology and cultural heritage features, and the Architectural Heritage Advisory Unit will comment on architectural heritage and built cultural heritage features.

The transposition of EIA requirements into Irish Law has to date focussed on the Planning and Development Acts. However, Regulations published in 2012 (SI 249 of 2012 – *European Union (Environmental Impact Assessment of Proposed Demolition of National Monuments) Regulations 2012*) amend the National Monuments Act 1930. In particular, these Regulations require the carrying out of an EIA where a decision to grant consent under section 14 (2) (a) of that Act, would result in the demolition of a national monument.

*‘The minister shall, before deciding whether or not to grant a consent or issuing of directions, as the case may be, would result in the demolition of a national monument, submit to the Minister an environmental impact statement in respect of that demolition’* (SI No. 249 of 2012).

In relation to electricity transmission projects in Ireland an EIA is mandatory for:

*Construction of overhead electrical powerlines with a voltage of 220 kilovolts or more and a length of more than 15 kilometres.*

*Industrial installations for carrying gas, steam and hot water with a potential heat output of 300 megawatts or more, or transmission of electrical energy by overhead cables not included in Part I of this Schedule, where the voltage would be 200 kilovolts or more.*

EIA may be required for sub-threshold development involving transmission of electricity by overhead cables where the voltage is below 220 kV or where the voltage is 220 kV and the length is less than 15km and where significant impacts on the environment are likely (as determined by the decision maker).

An Environment Report (ER) is generally prepared for development of new major transmission projects which do not require EIA.

### 3.2 Project Development

The nature of a major electricity transmission project is an evolving process, from broad considerations of the area within which the project could feasibly be located, to the specific route or site of a proposed development. In this context, these Guidelines identify a number of steps for the appropriate and comprehensive consideration of cultural heritage during the evolution of a project. These are set out in Table 3.1 below. These steps should be considered and addressed in all major electricity transmission development projects to ensure cultural heritage is appropriately, comprehensively, and consistently, addressed.

**Table 3.1 Summary of the Cultural Heritage Steps to be Considered in Planning EirGrid’s Major Transmission Projects**

| Steps  | Cultural Heritage Best Practice   | Consultation                               | Report Section |
|--------|---|--|----------------|
| Step 1 | Identification of cultural heritage assets and potential constraints                        | <b>Public &amp; Statutory Consultation</b> | Section 4.2    |
| Step 2 | Cultural Heritage Route Corridor/ Site options assessment study                             |  | Section 4.3    |
| Step 3 | Cultural Heritage route/site corridor evaluation (preferred route/site within the corridor) |  | Section 5      |
| Step 4 | Cultural Heritage Impact Assessment   |  | Section 6      |
| Step 5 | Environmental Management Plan – cultural heritage mitigation measures in place              |  | Section 7      |

### 3.3 Consultation

Consultation with statutory and non-statutory bodies, as well as with the general public and other stakeholders, is an essential part of the cultural heritage impact assessment process. It is important that consultation is initiated at the earliest stages of the planning process as the resulting information can inform and guide the process.

Early consultation ensures that cultural heritage issues are considered in a timely manner and allows for the relevant authorities to consider all information, and to respond and request any additional surveys. Planning and statutory authorities are also responsible for managing nationwide surveys and data relating to cultural heritage which should be considered in the assessment. Within their functional area, planning authorities may have a significant amount of relevant local knowledge which may aid the accuracy and analysis of likely significant cultural heritage effects. In addition, the general public or local heritage groups can often provide invaluable information or knowledge regarding local features that might not otherwise be mapped.

As a project progresses, detailed consultation will be required with statutory and non-statutory consultees, as well as with landowners. The level of this consultation depends on site specific issues and scope of the project work.

Appendix 3 contains the current contact details for statutory consultees. Additional potential consultees are provided in the EPA *Advice Notes on Current Practice in the Preparation of EIS (2003)*. An assessment of relevant consultees required for a specific development should be undertaken for each project in order that all potential issues are addressed appropriately.

### Table 3.2 Statutory Consultees

#### Statutory Consultees

National Monuments Service, Department of Arts, Heritage and the Gaeltacht (DAHG)

Architectural Heritage Advisory Unit, DAHG

The relevant Planning Authority – Heritage Officer and Conservation Officer

The Heritage Council

An Taisce

Fáilte Ireland

The Arts Council (An Chomhairle Ealaíon)



View to Tower House County Clare with transmission structures in the background

## 4. Cultural Heritage Requirements: Steps 1 & 2

### 4.1 Introduction

This section sets out the first and second steps required to comprehensively address cultural heritage in the development of major transmission infrastructure projects. These steps comprise identification, gathering and compilation of the baseline cultural heritage data, and an understanding of constraints within a given area :

- Step 1 the identification of cultural heritage constraints within a defined study area
- Step 2 the route corridor /site options assessment study

### 4.2 Step 1: Cultural Heritage Constraints Study

The objective for the cultural heritage constraints study is to provide a high level understanding of the key likely significant constraints within a given study area. It is a tool to ensure that cultural heritage assets are considered alongside all other environmental constraints at the earliest possible stage of the transmission system planning process and that consideration is given to all alternatives. The information contained within the constraint study will be used to assist the decision making process and inform the design and planning of a scheme.

Constraints study reporting will display basic data to illustrate the extent of key cultural heritage considerations and assist in strategic decisions for the study. It will:

- Assist in making strategic & preliminary routing decisions (including consideration of technology options)
- Produce a high level assessment

#### 4.2.1 Constraints Study Approach

The constraints study comprises a desk based review of readily available information on the recorded archaeological and architectural heritage constraints within the study area and their legal status. Using the RMP, RPS and NIAH sites the report provides a preliminary schedule of sites and land areas of significant archaeological and architectural heritage importance and potential.

The following cultural heritage constraints that lie within the study area should be listed:

##### **Archaeological Heritage:**

- UNESCO World Heritage Sites and those monuments on the tentative list
- National Monuments in State care and with Preservation Orders (as listed by the National Monuments Service of the Department of Arts, Heritage and the Gaeltacht).
- Sites listed in the RMP and the Sites and Monuments Record (SMR)
- Sites listed in the Register of Historic Monuments
- Sites listed in published County Archaeological Inventories and Surveys
- Information, where relevant, from the Urban Archaeological Surveys, Town/County Development Plans and relevant published information

##### **Architectural Heritage:**

- Record of Protected Structures (RPS)
- Architectural Conservation Areas (ACA's)
- National Inventory of Architectural Heritage (NIAH) – Buildings Survey (NIAH ratings values are international, national, regional, local and record)

- National Inventory of Architectural Heritage (NIAH) Garden Survey
- Information where relevant from the Town/County Development Plans and relevant published information

#### **Cultural Heritage:**

The RMP, RPS or NIAH encompass cultural heritage features. Additional features will be identified at route selection/EIS/ ER stages through field inspection, documentary and cartographic research and local consultation. These features will be recorded, mapped and assessed.

### **4.2.2 Contents of the Constraints Study Report**

In assessing the constraints of a specified study area the cultural heritage report should include the following:

#### **4.2.2.1 Introduction to the Study Area**

A non-technical introduction that provides a summary of the proposed development and the cultural heritage constraints identified within a defined project study area, the sources availed of, and a list of the legislative framework and guidelines consulted for the study. Any limitations or difficulties encountered during the compilation of the data should be noted.

#### **4.2.2.2 General Discussion and Evaluation of Archaeological /Architectural Constraints**

Using the baseline information gathered, the constraints should provide a preliminary discussion and evaluation of the existing statutory recorded archaeological and architectural heritage presence within the study area that would present constraints on development.

A brief discussion on the general character and nature of heritage assets within the study area, and what should be taken into consideration during the design process, for example, the nature of demesnes, their curtilages and attendant grounds, and associated structures, complexes, historic landscapes, designed landscapes, high visibility and low visibility sites and below ground archaeological potential.

#### **4.2.2.3 Conclusions**

A summary of the key considerations and any potential emerging issues for special attention in later phases of the process should be highlighted; for example notable clusters of features, sensitive landscapes or nationally significant cultural heritage assets that should be avoided.

#### **4.2.2.4 Table of Archaeological /Architectural Constraints**

The results are provided in an archaeological and an architectural heritage table, listing each individual site type, their location and their legal status. The table should include the following information for each site:

- Reference (RMP/ RPS number)
- Legal Status (the level of protection applied to the site)
- Townland (name of townland)
- County (name of County)
- Site Type (the type of archaeological monument/feature/structure)
- Name of structure (if relevant)
- NGR (National Grid Reference) (if available)
- Information Source (location, date accessed)

#### **4.2.2.5 List of Sources Consulted**

The report should include a detailed bibliography and list of sources consulted including online sources and the time and date when publically accessed and downloaded.

### 4.2.3 Mapping of all Cultural Heritage Constraints

The report should be illustrated with a map /maps showing all archaeological and architectural heritage sites/features with statutory designation within the study area. This exercise illustrates the key considerations and constraints in the identified study area in relation to cultural heritage and provides an understanding of their designations and their spatial distribution at a high level.

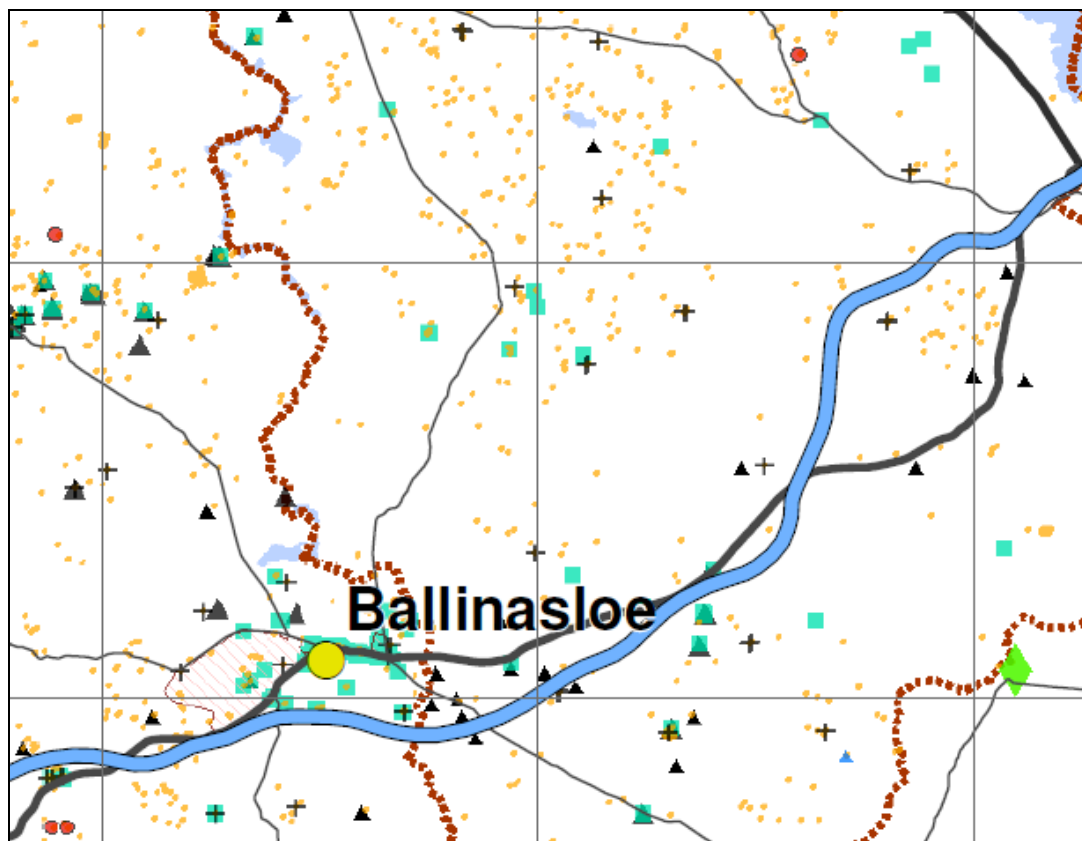

Figure 4.1 Example of an Architectural Heritage Constraints Map Illustrating Different Types of Designations taken from Grid West Constraints Report Vol 2 Fig.11.1.

The use of Geographical Information Systems (GIS) is an essential tool, particularly where the study area is extensive. The use of GIS allows the different layers of information to be manipulated and provides a rapid analysis of spatial data on an interdisciplinary basis. It also provides a link to the inventory, as all mapped sites are linked to a database that can be accessed through selecting an individual site. Available open source datasets include the RMP ([www.archaeology.ie](http://www.archaeology.ie)) and NIAH ([www.buildingsofireland.ie](http://www.buildingsofireland.ie)), the NIAH garden survey and [www.myplan.ie](http://www.myplan.ie)<sup>11</sup>. The use of GIS will be dependent on the approach that the lead consultant/EirGrid takes to the project.

<sup>11</sup> The RPS are not widely available as datasets, this information is not presented in a standardised way across each local authority and the spatial data is not available for all counties.



#### 4.2.4 Consultation

Consultation with the National Monuments Service and the Architectural Heritage Advisory Unit of the DAHG should be established, and a review of the findings of the report should be undertaken to ensure that all conclusions are in keeping with best practice and policies.

The cultural heritage constraints and results of the report should be clearly articulated to the client and design team. The public and all interested parties may be invited to engage with the project team and comment on the constraints study. Further cultural heritage information will feed into the work of the project team in further stages of the process.

#### 4.2.5 Constraints Study Checklist

- Consult and compile available information
- Tabulate all statutorily recorded archaeological sites and monuments within the study area: RMP, National Monuments, PO, RHM
- Tabulate all statutorily recorded architectural heritage sites within the study area: RPS sites, NIAH building sites
- Note major features within the study area that require avoidance
- Highlight issues of special attention or areas of emerging key cultural heritage potential
- Prepare a map showing all recorded cultural heritage constraints within the study area
- Respond to public consultation feedback
- Workshop with design team



**View to Castlebar-Dalton 110kV overhead line with a children's burial ground (CBG) and church site (MA079-061001) immediately adjacent. A castle site (MA079-061-001) is located in the background obscured from view by the trees.**

### **4.3 Step 2: Route Corridor/Site Options Assessment**

Taking into consideration the multi-disciplinary constraints studies, the project design team identifies and presents potential route corridor options for assessment.

The objective of the corridor assessment is to identify the potential cultural heritage issues along each of the identified potential corridors, and to undertake a comparative evaluation and assessment of them.

#### **4.3.1 Route Corridor Approach**

The route corridor assessment builds upon the baseline information compiled for the constraints study. It involves a combination of desk study, consultation and field walkover /vantage survey (i.e. a drive-by survey observing key heritage assets) to identify, map, describe and evaluate sites of known or potential cultural heritage value. Field work is necessary at this stage in order to broadly characterise the landscape in which the transmission project is placed. It provides a context for understanding and identifying the setting and survival of cultural heritage asset types. It informs the design team of the significance of the sites and features that may be potentially impacted by a transmission line within the corridor options. The process of route corridor identification will always seek to avoid international and nationally significant cultural heritage constraints for example UNESCO World Heritage Sites (WHS), tentative WHS and national monuments.

The report should include a statement of how the study was carried out and survey techniques used, including the data and information sources used and all consultations carried out.

### 4.3.2 Identification of Cultural Heritage Assets

To further develop the cultural heritage baseline a comprehensive literature research of all relevant publicly available and published material should be carried out, including cartographic sources and aerial photography.

Field survey as part of the route corridor identification process may be required to verify the results of the desk study and ensure that sufficient data is available to enable decisions to be made on the choice of route corridors. For example to verify the nature, location, extent and condition of significant constraints, to ensure the accuracy of the existing documentary record, to establish the setting or amenity of a monument, and to explore the potential significance of monuments identified through desk-study research and public consultation.

The route selection report should include details and descriptions of the following:

- Sites/features confirmed through the public consultation process
- Newly identified sites through the desk study or aerial photography
- Investigation of notable clusters of sites and their landscape setting
- Consideration of sites and landscape features that may extend beyond what is stated in the record for example tower houses may have a bawn, a country house may have an intact/relict demesne
- The archaeological potential of the landscape given an assessment of the terrain (for example rivers, bogland, unexplored uplands) and an examination of the type, density and distribution of archaeological sites within the landscape.
- Natural features may influence the siting of certain site types and provide a general assessment of the historic landscape, for example, waterways, lakes, rivers and bogland . need to be acknowledged as areas of archaeological potential and as features that are likely to have attracted settlement, ritual and industrial activity in the past and up to modern times (an example of historic landscapes and the site types located is included in Appendix 4)

While the study should focus primarily on the route corridors under consideration, assessment should be made of the general landscape types through which the corridor passes as this can help identify areas of archaeological and cultural heritage significance that may extend outside the route corridor eg if a country house lies outside the corridor and its significant historic demesne lies within the corridor there is a potential that it will be indirectly impacted. Reference should be made to **Tables 2.1 and 2.2**.

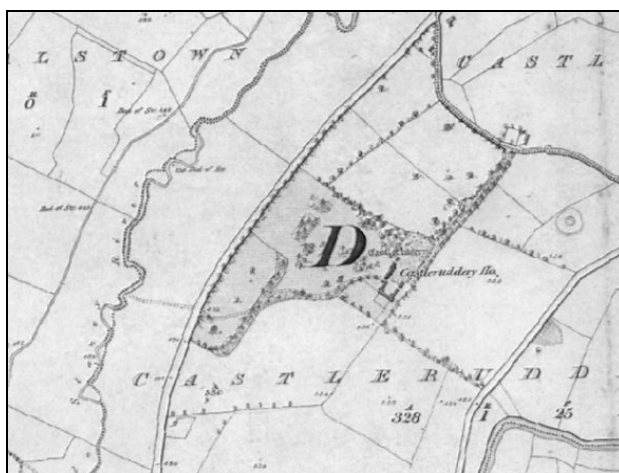

Figure 4.2 First edition Ordnance Survey 6-inch map showing an historic demesne and archaeological monuments

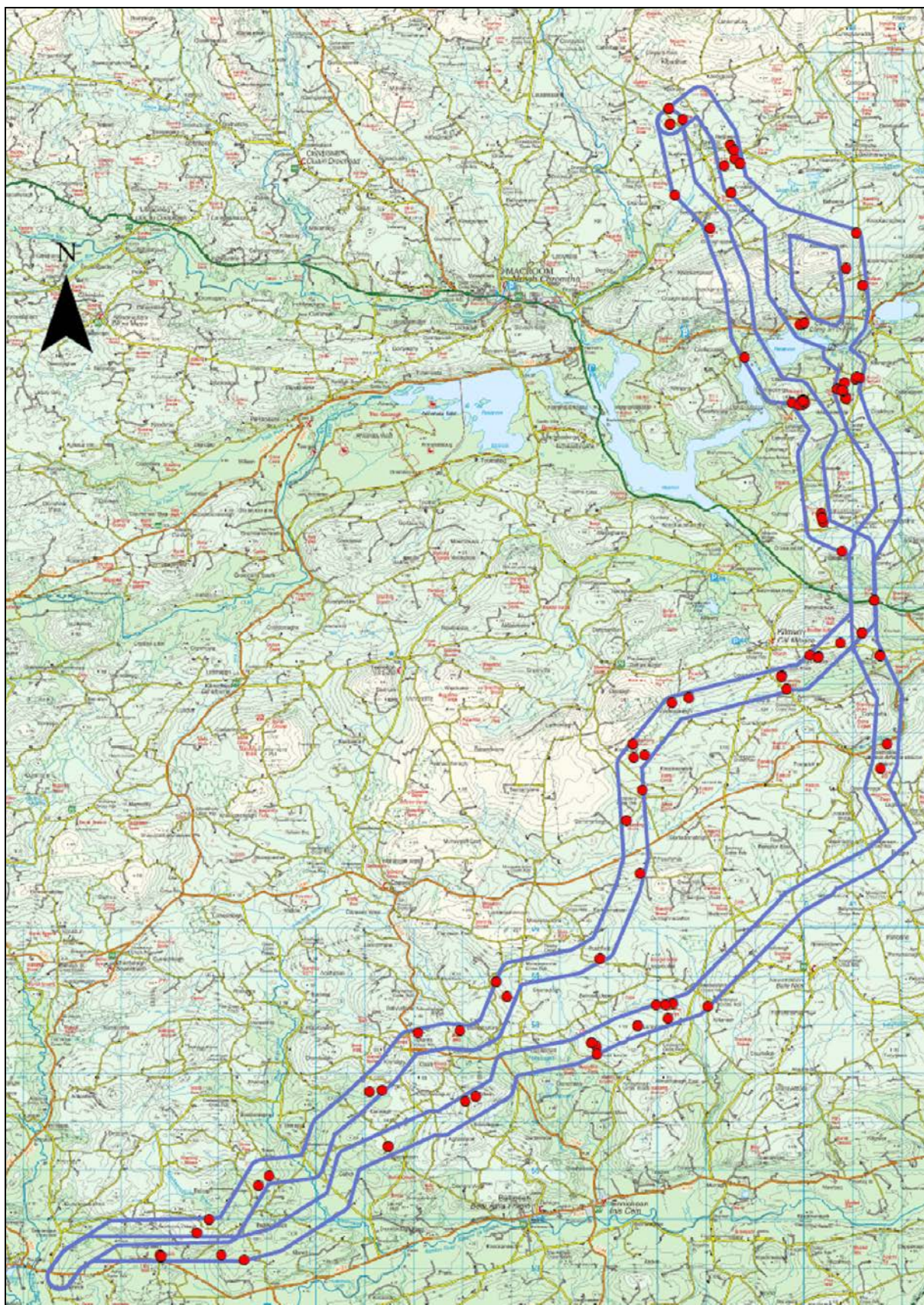

Figure 4.3 Example of mapping showing recorded monuments within identified potential route corridors for a high voltage overhead line transmission project, OS Discovery Series 1:50,000. Taken from the Clashavoon- Dunmanway 110kV Assessment of Corridors Reports – Cultural Heritage (AOS Planning Limited September 2010).

### 4.3.3 Inventory of Cultural Heritage Constraints

For each corridor, every recorded monument/ site/ structure/ feature or place of cultural heritage merit encountered must be compiled in a cultural heritage inventory, list, or held within a GIS. If the data is being displayed as an inventory it may be useful to include the following information:

- Unique Identification number
- Reference number (RMP No./County Inventory No. if applicable)
- Legal Status (distinguish the level of protection applied to the site i.e. national monument, protected by preservation order, registered site, RMP site, and newly identified site should also be noted or RPS site, NIAH sites of international, national, regional and local level)
- Townland
- County
- Site Type (the type of site)
- NGR (National Grid Reference)
- Map Reference
- Description (detailed description of site)
- Approximate date
- Sources (documentary, cartographic, aerial survey, consultation)

The inventory will list each individual site type, location and legal status. The means of identification will be referenced, whether it is from documentary, cartographic, aerial photography, field work or local consultation. Where there is a complex of sites (for example a mill, mill race, tail race and pond) they should be considered as one unit; even though the complex may have many designations. It should be given a single reference number, and marked as a unit on the accompanying map. This will highlight the significance of the site as a complex.

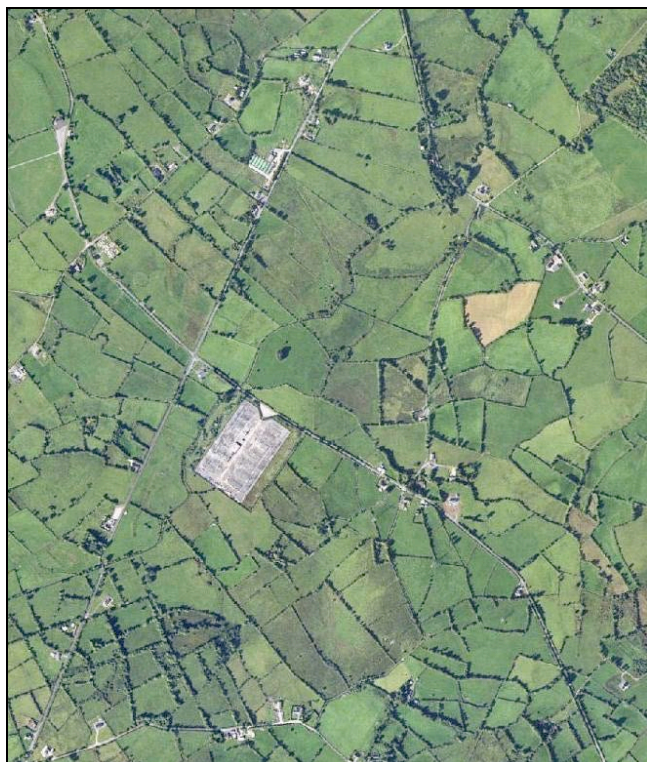

**Aerial photograph showing a substation and surrounding landscape. Aerial photography is a useful source at route selection stage. It provides the consultant with a new perspective of the historic patterns in the landscape that cannot always be perceived on the ground. The use of aerial photography and cartographic sources is a powerful tool in tracing historic changes in the landscape and identifying previously unrecorded heritage assets and relict settlements**

**Table 4.1: A Sample Entry from a Route Corridor Inventory**

|                            |   |
|----------------------------|---|
| <b>Reference Number</b>    | ID 3  |
| <b>Reference No:</b>       | RPS 09-02, NIAH site 16400902   |
| <b>Legal Status</b>        | Protected Structure, NIAH regional importance   |
| <b>Address</b>             | Britonstown/Blakestown Lower, Blessington   |
| <b>Location/ Co-Ord.</b>   | 294646, 208313  |
| <b>Site Type</b>           | Poulaphouca Dry Road Bridge   |
| <b>Description</b>         | Single-arch road bridge over a dry channel of the Pollaphuca River, built c.1830. The bridge is rubble-constructed with battered abutments. A tall narrow pointed arch supports the carriageway whilst the road margins are carried on higher level Tudor arched recesses of wider span. The former arch has moulded voussoirs whilst those of the recesses are of rough stone; a shield-shaped panel is set between the arch and the recess. |
| <b>Approx. date</b>        | 1830  |
| <b>Sources</b>             | NIAH (16400902), Wicklow County Development Plan (CDP) RPS, field survey  |
| <b>Additional Comments</b> | Any other general observations gained during fieldwork or research  |

#### 4.3.4 Comparison of Route Corridor Options

The process of selecting a least constrained corridor for a proposed transmission line project typically involves a comparative evaluation of a number of corridor options so that the route corridor with the least constraints from a cultural heritage, and all other environmental, technical and economic perspectives can be selected. This often requires an appropriate balance between competing criteria. A comparative and qualitative evaluation of the heritage assets within each route corridor option should be carried out to assist in the identification of the least constrained route option.

The assessment of each corridor should take into account the statutory protection of each of the cultural heritage assets that lie within it and are recorded in the inventory. Other factors (see Table 2.1 Section 2) to be considered may include, but are not restricted to:

- Physical presence in the landscape (Scale, mass, appearance, setting and visibility)
- Preservation (integrity, condition, vulnerability to change of the heritage asset)
- Documented value and material about the heritage asset
- Complex of site and group value, inter-visibility between heritage assets
- Rarity in the heritage record
- Cultural and community value

A route corridor matrix (Table 4.2) showing the occurrence of features of cultural heritage merit within the route option corridors allows a comparison of each route to take place. This enables an informed contribution from the cultural heritage consultant into the identification of the least constrained route corridor option. A quantitative and a qualitative approach is necessary when selecting a route corridor, and all decisions taken must be recorded.

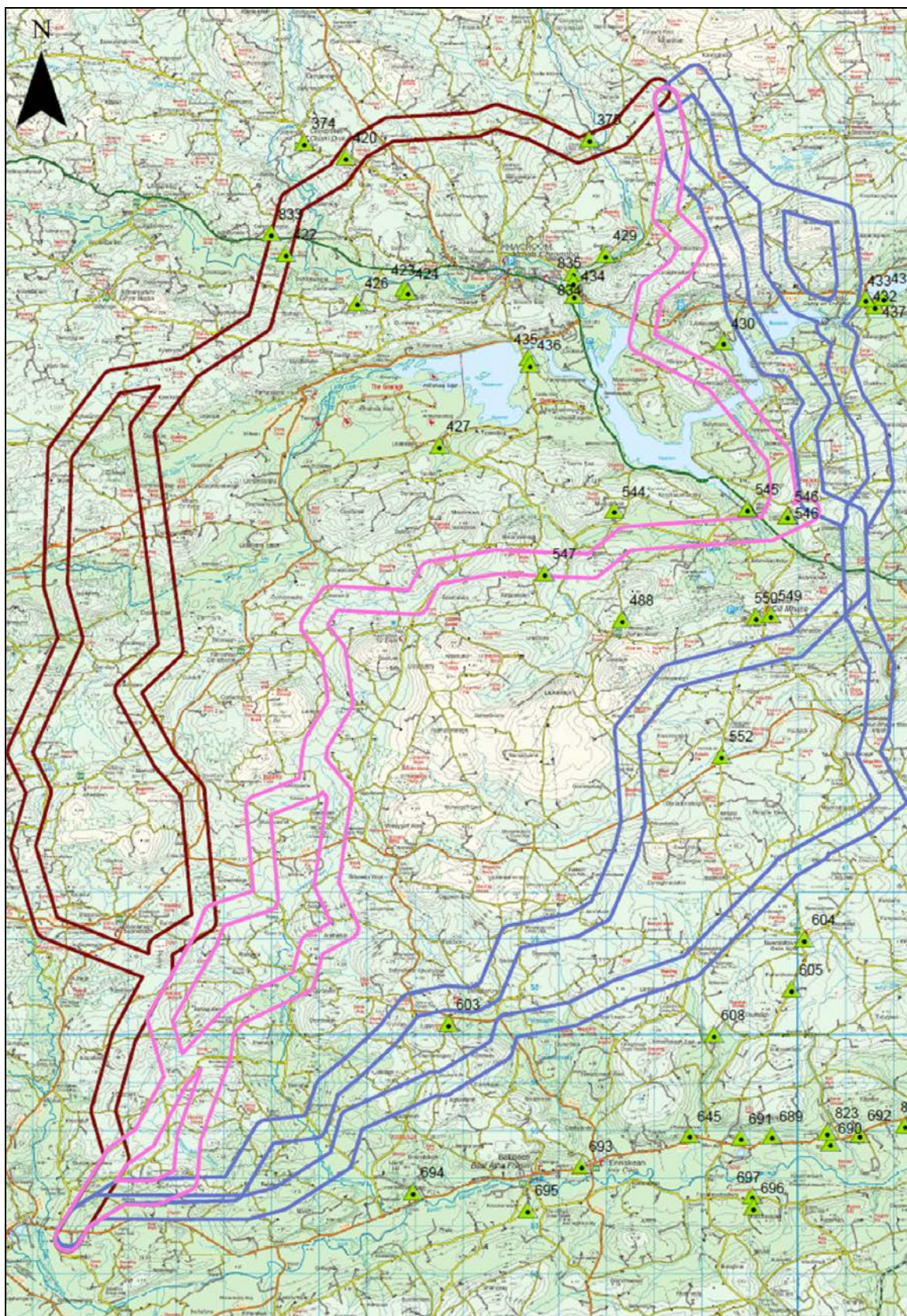

Figure 4.4 Example of mapping showing records of Protected Structures within and adjacent to identified potential Corridors for a proposed high voltage overhead line project OS Discovery Series 1:50,000. Taken from the Clashavoon-Dunmanway 110kV Assessment of Corridors Reports – Cultural Heritage (AOS Planning Limited September 2010).

### 4.3.5 Summary Route Corridor Matrix

**Table 4.2 Example of a Route Corridor Summary Matrix**

| Qualitative Measurement<br>Heritage Asset  | Number of occurrences Quantitative measurement  |  |   |
|--|---|--|---|
|  | Route Option 1  | Route Option 2   | Route Option 3  |
| Candidate World Heritage Sites   | 0   | 0  | 0   |
| National Monuments (NM) temporary preservation orders (TPO) Register of Historic Monuments (RHM) | 3 (henge site and castles (2))  | 0  | 1 Church site   |
| Record of Monuments and Places (RMP)   | 8 (complex of barrows (4), ecclesiastical complex, stone fort and ringforts (3), burnt spreads (2)) | 3 (ringforts (2), enclosures (1))  | 6 (motte and bailey, fulachta fia (3), holy well and church site) |
| Architectural Conservation Areas (ACA's)   | 1 (rural village)   | 0  | 0   |
| Record of Protected Structures (RPS)   | 4 (mill sites (2), principle residence of a demesne, graveyard)                                     | 2 (canal lock, Martello tower)   | 3 (bridges (2), demesne structure (1),                            |
| NIAH Buildings Survey sites (record, local, regional national & international rating values)     | 6 (gate house (2), school building, entrance gates, pill box, farm building)                        | 5 (quay walls, vernacular farm buildings (4))                            | 4 (industrial stone buildings (3), court house)                   |
| Undesignated archaeological/ architectural/ cultural heritage sites of merit                     | 1 (penal mass site, visited on pattern days)  | 2 (ruined, 19 <sup>th</sup> century vernacular ruined cottages)          | 2 (bridge structure and booley hut)                               |
| Other potential  | Navigable river valley, large number of multi-period stray finds<br>Gaeltacht area                  | Raised bogs (extensively milled), local record of bog butter being found | Pasture and bogland.  |
| <b>Preference</b>  | <b>Least Preference</b>   | <b>First Preference</b>  | <b>Second Preference</b>  |

Generally, the route corridor option with the lowest number of statutory and non-designated heritage assets contained within it will be the least constrained option from a cultural heritage perspective. The route with the greatest number will be the least preferred. However this is not always the case, and the experience and professional judgement of the consultant should be applied.

For example a route corridor may have several recorded monuments within it, but these may be predominately low-lying or subsurface sites; whereas another corridor may have several well preserved upstanding stone monuments with large amenity areas around them. This may lead to a preference in favour of the route corridor with the greater number of sites.

The reasoning for selecting the preferred route corridor must be detailed in the text in a clear decisive manner, and consideration has to be given to the known nature and significance of the heritage asset.

It should also be noted that the least constrained route corridor, from a cultural heritage perspective, may not actually be the overall identified least constrained route corridor, when other technical, environmental, economic and other criteria are applied. Route corridor identification therefore generally occurs in a workshop-based dialogue involving the whole project team.



An associated objective of the route corridor selection study is also to indicate to the project design team areas within each corridor that, where possible, should be avoided as part of the design of a route within it.

#### 4.3.6 List of Sources Consulted

The report should include a detailed bibliography and list of sources consulted, including online sources and the time and date when public files were accessed and downloaded. Some sources that might be used include:

- List of National Monuments in State Care: Ownership & Guardianship
- List of Preservation Orders and the Register of Historic Monuments
- Record of Monuments and Places (RMP)
- Files of the Sites and Monuments Record (SMR)
- Updated SMR available at [www.archaeology.ie](http://www.archaeology.ie)
- Published County Archaeological Inventories and Surveys
- Maritime Sites and Monuments Record
- National Inventory of Architectural Heritage (NIAH) Building Survey
- National Inventory of Architectural Heritage (NIAH) Garden Survey
- County and Town Development Plans
- Irish Antiquities Division, National Museum of Ireland Topographical Files
- Urban Archaeological Surveys
- Irish Architectural Archive
- Ordnance Survey first and subsequent editions, [www.osi.ie](http://www.osi.ie)
- Ordnance Survey Name books / Letters / Memoirs
- National Folklore Collection
- Early maps and estate maps
- Office of Public Works river drainage files
- Aerial photographs
- Excavations Bulletin ([www.excavations.ie](http://www.excavations.ie))
- Relevant published archaeological corpora
- [www.loganim.ie](http://www.loganim.ie) (for townland names)

#### 4.3.7 Consultation

Public consultation and dialogue with interested parties such as local historians, archaeological societies and the general public are often an invaluable source of local information. They can be a key factor in identifying unrecorded cultural heritage features such as events and traditions that are locally known but not officially recorded. This information assists in further refining route corridors.

Consultation with the DAHG will continue through the route corridor selection stage to discuss the preliminary findings of the report. Local authority conservation and heritage officers should also be contacted in relation to community-based heritage records/projects. Workshops with the design team will assist in project communication.

### 4.3.8 Report Format

The cultural heritage report should take the format of:

- a non-technical introduction
- methodology
- a description of the receiving environment and the identified route corridor options
- an impact assessment of each route corridor option
- a comparative analysis of each corridor, and
- general conclusions including issues within each corridors and areas that must be avoided.

### 4.3.9 Route Corridor Selection Study Checklist

- Define cultural heritage assets from desk based research, cartographic sources, fieldwork and consultation
- Field survey/site inspections
- List cultural heritage assets within each route corridor
- Consultation with statutory authorities
- Prepare route corridor comparison matrix
- Assessment of corridor options
- Prepare final report and mapping
- Recommendations for further work/assessment (which may require additional specialisations e.g. geophysical survey or archaeological testing)
- Interdisciplinary workshops focussing on refining corridor routes



View to Tarbert Power Station, Co Kerry recorded as a Battery (KE003-002--) and a Bastioned Fort (KE003-001--) in the Record of Monuments and Places (RMP)

## 5. Cultural Heritage Requirements: Step 3 Preferred Corridor /Preferred Site Evaluation

### 5.1 Preferred Corridor/Preferred Site Evaluation

Step 3 consists of evaluating the preferred route corridor or preferred site by reviewing the material and data collated during Steps 1 and 2 of the process. It also involves assessing stakeholder feedback as well as ongoing technical and environmental work. This re-evaluation may result in minor modifications of the least constrained corridor. It could, in theory at least, result in identification of an alternate route corridor option.

All modifications will be assessed to determine if they change the preference for the identified route corridors. Based on this assessment a preferred corridor is identified.

Following identification of the preferred route corridor, an indicative live route terrain will be identified therein. This will seek to 'best fit' within the preferred corridor, from a technical, environmental and other perspective.

The output for this stage includes a detailed review of all consultation and stakeholder feedback. Any resulting modifications to the emerging preferred route will be documented in a Route Corridor Evaluation Report.

## 5.2 Preferred Route/Preferred Site Evaluation Checklist

- Assess and review stakeholder feedback
- Re-evaluate and document all modifications to the preferred emerging route/site
- Identify further analysis and investigation required
- Identify if further field survey/site inspection is required
- Inter-disciplinary project team workshop on the emerging preferred route



220 kV Clashavoon – Tarbert and stone circle (CO059-011), Co Cork

## **6. Cultural Heritage Requirements: Step 4 Cultural Heritage Impact Assessment**

### **6.1 Introduction**

The objective of the cultural heritage impact study is to identify, quantify and qualify likely significant impacts. Significant impacts are those which by their character, magnitude, duration or intensity alter a sensitive aspect of the environment.

In preparing either an EIS or Environmental Report (ER), reference should be made to the following guidance notes:

- The EPA Guidelines on the Information to be Contained in Environmental Impact Statements, 2002 and
- Guidance on EIA – EIS Review, European Commission, 2001
- EIA, Guidance for Consent Authorities regarding Sub-Threshold Development, Department of Environment, Heritage and Local Government, 2003

The legislation governing the EIA process requires information on 'significant' impacts. The EIS/ER should also consider potential impacts on all elements of the proposed transmission development including structures, substation, cabling and access routes. Consideration of mitigation measures to address potential impacts should be in the following order:

- Mitigation by avoidance
- Mitigation by reduction
- Mitigation by remedy

### **6.2 Approach**

The EIS/ER study incorporates and develops information contained in the Constraints Study and the Route Corridor Selection Study (Steps 1–3). The approach in order to comply with the EIA Directive should incorporate the following elements:

- Consultation
- Description of the Existing Environment
- Survey Requirements
- Evaluation
- Impact Prediction/Assessment
- Mitigation
- Interactions

#### **6.2.1 Consultation**

##### **Project Team**

To ensure that key construction decisions have been fully considered and assessed in relation to cultural heritage, ongoing consultation with the project design team is required. Of particular importance is liaison between the designers and engineers as well as landscape and visual consultants. This is in order that the setting of cultural heritage assets and interactions between the various environmental topics addressed can be fully and robustly assessed. Where necessary, liaison

between heritage consultants working on the same project will ensure consistency between archaeological and architectural heritage sections of the report.

### Statutory Consultees

Early consultation as described in **Section 3.3** is essential for a comprehensive scoping process and identification of specialised surveys dependent on the needs of the project (Appendix 3, lists statutory consultees).

Ongoing consultation with statutory consultees is important to ensure that the decision making process is clear and transparent, and subject to review by external, independent cultural heritage advisors. It also ensures that consultees are provided the opportunity to comment.

### Non-Statutory Consultees

Consultations with local interest groups and organisations may aid the gathering of further information and data necessary to make an assessment on the significance of cultural heritage assets.

## 6.2.2 Description of the Existing Environment

From the perspective of cultural heritage assessment, one of the primary purposes of the EIS/ER is to assess the significance of the receiving cultural heritage environment. This description will utilise information and reports from previous steps in the process and will involve new survey work to generate up-to date and site specific data on cultural heritage assets. The description of the existing cultural heritage environment is the foundation for the impact assessment process, as a prediction of change is only as effective as the baseline data collected.

The cultural heritage information of the proposed transmission project and associated ancillary development needs to be described to a standard which allows for accurate impact predictions to be made. A standardised approach will assist practitioners in providing robust assessments upon which the relevant adjudicating authority can make a decision in a clear and practical manner.

The following should be considered in describing the cultural heritage baseline:

- A review of information contained from the earlier stages of the project.
- A review and collation of information obtained from public and statutory consultees, for example nationwide surveys such as the RMP, NIAH, RPS and landscape characterisation.
- A review of published and key references appropriate to the study area including material from local interest groups and historical and archaeological societies.
- A review of artefactual material held in institutions and local and private collections (where possible).
- Collation of information from similar or other infrastructure projects in the study area, for example EISs, SEAs, conservation plans, archaeological test assessments and excavations.
- A review and interpretation of aerial photographs to be used in combination with historic mapping to map potential cultural heritage assets that may be investigated as part of the field survey.

An accurate description of the existing environment is necessary to predict the likely significant impacts of a new transmission project. This information also provides a valuable baseline which can be used for monitoring of the impacts of the project, once it is in operation.

The type and extent of sources to be availed of during the ER/EIS process will ultimately depend on the research that has been carried out in any given area.

The description of the cultural heritage environment should provide sufficient data to facilitate the identification and evaluation of the likely significant effects on this topic. Systematic, accurate and comprehensive descriptions are to include:

**Context** – description of location, extent and magnitude of affected heritage assets,

**Character** – indication of distinguishing aspects of cultural heritage features under consideration,

**Significance** - detail the quality, value and/or designations that are assigned to heritage assets and historic cultural landscapes,

**Sensitivity** – description of what changes could significantly alter the character of cultural heritage assets, for example is the heritage asset under threat or vulnerable from proposed changes.

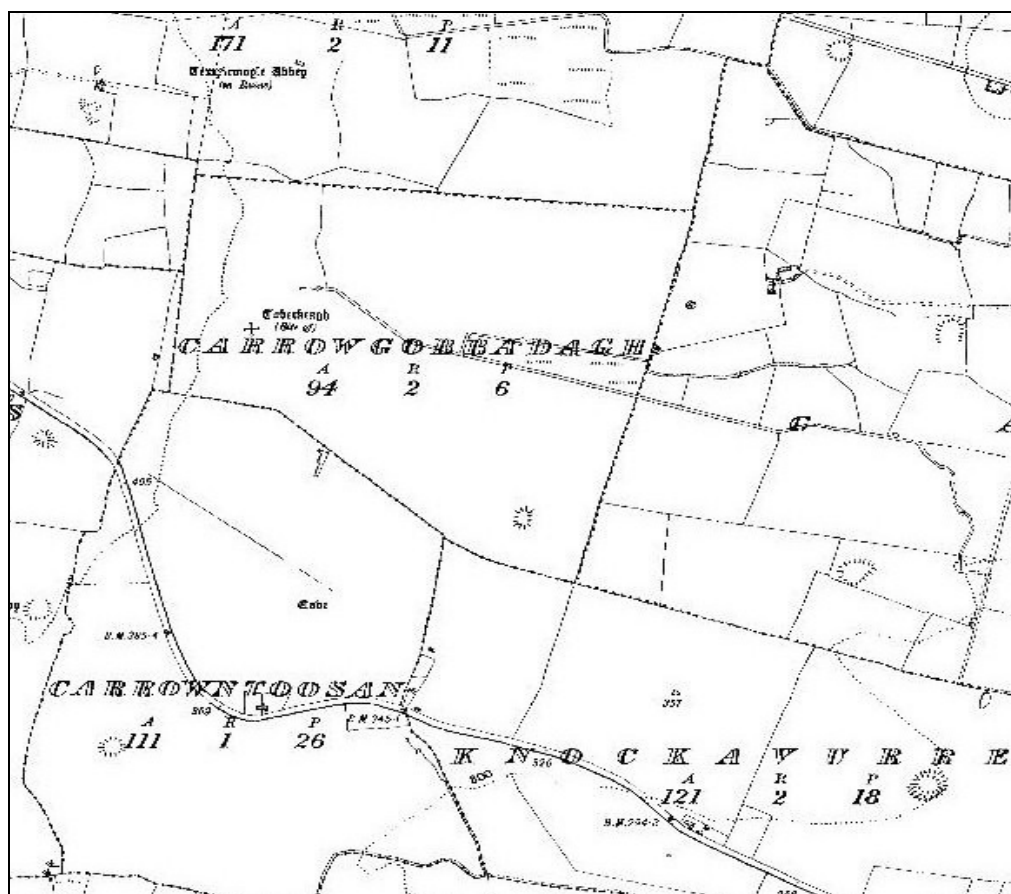

Figure 6.1 First Edition Ordnance Survey 6-Inch Mapping Showing Field Systems and Archaeological Monuments

### 6.2.3 Survey Requirements

A cultural heritage field and site inspection (where access to lands is permitted) forms part of the baseline study and overall reporting to ensure an accurate impact assessment addressing the likely and significant impacts. For each survey a detailed methodology should be produced appropriate to the project. The survey will describe the existing cultural heritage environment and all encountered heritage assets associated with transmission infrastructure. Where there is an identified impact on a heritage asset, an assessment should be made as to the type and significance of the impact.



**Previously unrecorded cup marked stone, Millstreet 220 kV/110 kV Substation Project. Courtesy of Byrne Mullins & Associates**

#### Standardisation of field reports

To facilitate a consistent, objective and thorough survey of selected sites, a comprehensive field recording form has been developed for EirGrid projects. This form includes a number of descriptive and subjective fields to address the range of heritage assets, and the diversity of landscapes and construction techniques.

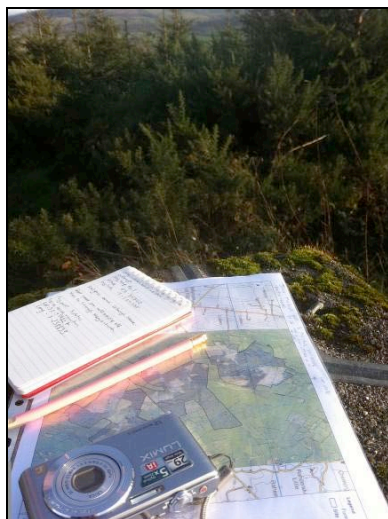

**Field work in progress: recording and mapping of heritage assets uses digital photography and GPS**

Consistency of the field report results will be aided by the use of a standardised field reporting form (Appendix 5 EirGrid Recording Form). This is especially important when there is more than one field operative on different sections of the same project. Applying field work in a systematic fashion will also ensure greater consistency.

#### Limitations

Any limitations, such as restricted access to lands or technical issues experienced in the field, should be clearly identified in the report. Where access is restricted, observations should be made from the



nearest freely accessible viewing point, and all available documented information and remote sensing data used to establish the potential impact. Difficulties encountered in carrying out the assessment (and in overall compilation of the EIS/ER) should be documented in the EIS/ER.

### Specialised Studies and Surveys

Specialised studies or additional surveys may be required, for example underwater, intertidal, aerial survey, geophysical survey, topographical survey to gain a greater level of certainty about a heritage asset. The need for, and the purpose of these surveys, should be established early in the cultural heritage impact assessment process.

## 6.2.4 Assessing Impact

The final location, scale and physical form that substations and overhead line structures may take is only confirmed at the EIS/ER stage of a major transmission project. It is at this stage that project and site specific effects can be identified, recorded and mitigated.

The significance of an impact is usually understood to mean either the importance of the cultural heritage asset that is affected (its sensitivity to change), or the importance of the outcome of the impact (the consequences of the change). Significance is determined by a combination of objective scientific and subjective social concerns.

### 6.2.4.1 Impact Prediction

Impacts are described as clearly and as directly as possible without the use of jargon. Terms should be presented consistently throughout the EIS process (Appendix 2 Glossary of Impacts, EPA 2002). Impacts can be direct, indirect or cumulative, or as having no predicted impact (Section 2.2)

Impacts which are caused by the interaction of effects, or associated off-site transmission developments are classified as indirect impacts. Cumulative impacts are often classed as indirect. Prediction of such impacts can be difficult until the full extent of design of the project has been established, together with appropriate mitigation measures.

Residual impacts can occur after the proposed mitigation measures have taken effect as planned. It is not always possible or practical to mitigate all impacts. Where this is the case then the residual impacts are clearly described.

### 6.2.4.2 Impact Level

An accurate description of the expected impacts and how this impact level is obtained should be explained and justified. Impacts can be positive, negative or neutral. The following four objective criteria are used to determine the significance of this impact level:

**Magnitude and intensity** – whether the effects occur over a wide area to a large number of cultural heritage assets.

- Quantify the amount by which the character/quality of the cultural heritage environment will change
- Indicate the spatial extent of the impact
- Describe the degree of change

**Integrity and character** – the degree to which the character or cultural heritage assets are enhanced or reduced.

- Identify the aspect of the heritage asset affected
- Describe quality of the impact whether it is positive, neutral or negative
- Highlight significant impacts (positive and negative)

**Duration** – the length of time that the impacts last. They can be temporary (for example during construction only) or can last for a long period of time (more than one generation). They may also cause permanent changes to any aspect of the environment.

- State whether the impact will be continuous, intermittent or occasional
- Indicate whether the impact will be temporary, short, medium or long-term
- Highlight permanent impacts

**Probability and consequence** – whether or not the magnitude, intensity, duration or consequences of any change can be anticipated with a reasonable level of certainty ie high or low.

- Identify features which will be affected, indicating their sensitivity and significance
- Indicate whether the impact can be avoided, mitigated or remedied
- Highlight irreversible impacts
- Highlight when the consequence cannot be determined, for example when there is a considered archaeological potential.

Using these criteria the type and extent, quality, duration and degree of certainty of the impact will be determined. The level of the impact is then assessed as being **Profound, Significant, Moderate, Slight** or **Imperceptible**. These terms are defined in Appendix 2.

**Table 6.1 Sample Impact Evaluation Checklist**

| Description               |  |   |           |   | Evaluation            |   |
|---------------------------|--|---|-----------|---|-----------------------|---|
| Impact                    | Character  | Magnitude                                     | Duration  | Consequence   | Significance          | Certainty   |
| Direct negative           | Disturbance of an upstanding well preserved ringfort site      | 20% of the site, eastern bank will be removed | Permanent | Loss of data  | Profound              | Low   |
| Indirect negative         | Impact on the setting of attendant grounds of a former demesne | Loss of character on the outer lands          | Permanent | Visual intrusion, the integrity of the demesne has been compromised by modern development | Minor                 | High  |
| Potential negative impact | Within an area that has barrow site complexes                  | Potential to reveal further barrow sites      | Permanent | Possible loss of data from subsurface site  | Significant potential | Low (appropriate archaeological investigation required) |

### Subjective Concerns

A heritage asset can acquire significance where society, a community or a significant number of individuals are concerned. This usually arises when an aspect of the transmission development may adversely affect a community or an aspect of heritage which is valued. Consultation is necessary to understand and address the nature of the concern. All decision-making processes should be clearly documented within the EIS.

### 6.2.5 Impact Assessment on Cultural Heritage Assets and Setting

Depending upon the siting of a substation and /or overhead line and associated support structures, the operation and presence of such infrastructure could potentially have adverse effects on the setting of the heritage asset. The significance of the effects on the historic and archaeological environment depends upon the perceived value of the heritage asset.

While change within the setting of an historic site or landscape may be acceptable, in certain instances development will be considered inappropriate. This effect on the setting of archaeological and cultural heritage sites requires an assessment to be made on a case by case basis. This assessment is made according to the type of tower and poleset development, its location and landscape setting by means of objective analysis based on a set of predefined criteria (see Tables 2.1 and 2.2) and professional judgement, supported by appropriate descriptive material. It is good practice to document each stage of the decision-making process in a non-technical way, accessible to non-specialists. The impact will vary according to the size and extent of the structure and the type of historic/archaeological landscape involved. In order to aid this assessment when considering designated and well-documented historic and archaeological landscapes, the capacity for that landscape to absorb new development should be reviewed, and the sensitivity of the existing landscape assessed.

When describing the receiving cultural heritage environment it is important to be aware of the changing and dynamic nature of any given environment. The description of the cultural heritage asset should provide any evidence of change as such information can alter the perception of cumulative impacts.

### 6.2.6 Inventory

A cultural heritage inventory of all heritage assets on or in proximity to transmission project infrastructure, will identify and record the type of impacts and proposed mitigation measures. The inventory is populated by the field recording form (Appendix 5) and checklist (Table 2.2).

**Table 6.2 A Sample Entry from a Cultural Heritage Inventory for EIS/ER**

|   |   |
|---|---|
| <b>Identification Number</b>                      | ID 3  |
| <b>Figure and Plate No.</b>                       | Figure 4, Plate 8   |
| <b>Reference Number</b>                           | RMP WM018-030   |
| <b>Legal Status</b>                               | Recorded Monument   |
| <b>Address/Townland</b>                           | Irishtown   |
| <b>Location/ Co-Ord.</b>                          | 294646, 208313  |
| <b>Site Type</b>                                  | Ringfort  |
| <b>Description</b>                                | Raised oval enclosure measuring 32m in diameter, bounded by a poorly preserved bank. Located grassland, the monument takes advantage of a natural hillock and enjoys good panoramic views.  |
| <b>Setting</b>                                    | Have regard to setting check list (Appendix 5 and Table 2.2). While the monument is partially denuded and disturbed by agricultural activity it sits on a prominent hillock in the landscape. An additional ringfort is located 150m to the east and an enclosure is located 110m to the southeast. |
| <b>Sources</b>                                    | RMP, Westmeath County Development Plan  |
| <b>Distance* from preferred route/ structures</b> | 55m west from the closest edge of the angle tower (Structure 122) and 92m southwest from double wooden pole set (45). Both structures are placed adjacent to field boundaries.  |
| <b>Type &amp; level of impact</b>                 | Indirect impact   |
| <b>Mitigation Measures</b>                        | Archaeologically monitor the excavation of the structure footprint (No. 122)  |

\*Distance is measured from the edge of the heritage asset to the closest edge of the proposed development

## **6.2.7 Description of Mitigation Measures**

Mitigation measures are devised in order to avoid, reduce or remedy significant adverse effects.

### **6.2.7.1 Mitigation by Avoidance**

This is the preferred method of mitigation. Consideration must be given to all impacts, and alternatives must be taken into account at the earliest stage of the EIS/ ER process. This type of mitigation may include minor realignments of a transmission project route in order to avoid heritage assets.

### **6.2.7.2 Mitigation by Reduction or Design**

This is a common strategy for dealing with effects that cannot be avoided and it seeks to limit the exposure to the heritage asset by record or excavation. For example, the recording of buildings of architectural heritage interest or where an archaeological site or monument cannot be avoided, the excavation of deposits and features will ensure that it is accurately recorded, archived and documented for public reference.

### **6.2.7.3 Mitigation by Remedy**

This is a strategy used for dealing with residual impacts which cannot be prevented from entering the cultural heritage environment and causing adverse effects.

Remedy serves to improve adverse conditions which exist by carrying out further works which seek to restore the environment to an approximation of its previous condition or to a new equilibrium. An example of mitigation by remedy would be reinstating buildings, walls or features and/or finding engineering and architectural design solutions that reduce the level of impact at any given heritage asset.

***Mitigation for adverse effects on the cultural heritage assets (adapted from Planarch 2, 2006)***

| <b>Mitigation Action</b>              | <b>Principle of Mitigation</b>   | <b>Examples of Mitigation Measures</b>   |
|---------------------------------------|--|--|
| <b>Prevent/ Avoid</b>                 | Change design or methods to prevent effects arising  | Reroute/re-site infrastructure away from a cultural heritage asset   |
| <b>Reduce</b>                         | Make a permanent public record of what is damaged /destroyed through measured survey, excavation, photographic record. | Reduce land-take in sensitive areas, landscape design to reduce visual/noise intrusion, adapt construction methods.      |
| <b>Remedy (Record)</b>                | Change design or methods to render effects less severe   | Fund excavation, post excavation analysis, building recording, deposit of archives in museums, publication and displays. |
| <b>Remedy (repair/restore)</b>        | Repair /reinstate any new damage on completion of construction.  | Restore landscape and structures.  |
| <b>Offset (enhance or compensate)</b> | Offset effects by carrying out off site works to compensate for losses and enhance local area.                         | Restoration of nearby assets. Improve access for local people, signage to nearby cultural heritage assets.               |

### **6.3 Report Format**

The cultural heritage section of an EIS/ER report should include the following:

- Introduction and description of the proposed transmission project preferred option
- Methodology and any limitations experienced during the course of the project
- A description of the receiving archaeological and historic environment including documentary research, detailed field inspection, review of aerial photography and historic mapping
- Specialised survey (as required)
- Inventory of cultural heritage assets and areas of potential cultural heritage significance
- Consultation with the statutory authorities and specialised bodies as required
- Impact assessment
- Proposed mitigation measures
- All necessary illustrations, photographs and mapping – the location of all cultural heritage assets including their setting where relevant, within and significant to a study area should be shown graphically.

The cultural heritage EIS/ER report should ultimately provide a description of the cultural heritage assets likely to be significantly impacted upon by the proposed route or siting option.

## 6.4 Study Checklist

- Collate data from Constraints and Route Corridor Options reports
- Undertake additional research in order to provide a robust and comprehensive assessment
- Conduct field survey/site inspections & record according to the field survey sheets
- Undertake specialist surveys as necessary and include the results in the ER/ EIS
- Provide a narrative of the existing cultural heritage environment
- Consult with statutory consultees and interested stakeholders
- Assess impact level on and setting of affected heritage assets
- Assess the archaeological potential of the landscape
- Provide an impact assessment of preferred route
- Detail proposed and feasible mitigation measures
- Provide illustrations, photographs and mapping to facilitate an understanding of the scheme
- Consult with the design team and landscape and visual consultant



Double wooden poleset in place in advance of erection on Donegal 110 kV Project (Binbane – Letterkenny)

## 7 Environmental Management Plan: Step 5

### 7.1 Construction Environmental Management Plan

A Construction Environmental Management Plan (CEMP) is a useful means of bringing together all mitigation and monitoring measures in order to avoid, reduce or where possible, remedy significant adverse effects on cultural heritage as identified during the EIA process prior to development consent being granted. Although not required under the current EIA legislation, the preparation of a CEMP is considered good practice and should be considered for all high voltage electricity transmission projects. It has become a standard condition of statutory approval by An Bord Pleanála for SID transmission infrastructure projects.

The CEMP serves as a commitment and a direct link between the EIS/ER and the implementation of previously assessed mitigation strategies by the contracted construction company. The CEMP can form part of the construction contract and there should be a requirement under the contract to report on the implementation of the CEMP during the construction and operation of the scheme.

The preparation of such a plan cannot be used to compensate for an inadequate EIS/ER or to develop mitigation measures not considered in the previously assessed EIS. The CEMP may not introduce changes from the permitted project, unless by prior agreement with the consent authority. Any changes may invalidate assessments undertaken.

All commitments including those agreed by the local authority and/or as required by conditions of consent subsequent to the publication of the EIS/ER must to be entered into the CEMP.

A plan may be required for each of the following phases:

- Construction phase (including pre-construction contracts)
- Operational phase (ongoing refurbishment and updates)

## 7.2 Practical Considerations

Meaningful environmental management of a project involves informing and training construction personnel in relation to cultural heritage issues and constraints and monitoring quality control programmes to achieve the project goal (CIGRÉ 1999) and to protect all cultural heritage assets.

Practical advice and training of onsite contractors and electricity personnel in relation to the identification and avoidance of archaeological/cultural heritage remains during on site transmission construction procedures are intended to ensure that every reasonable effort is made to identify and minimise adverse impacts on cultural heritage remains.

Mitigation measures should be unambiguous, clear, definitive and feasible to implement. When compiling a CEMP it is important to use authoritative language (for example 'will' and 'shall') and to avoid the use of ambiguous language (for example 'would' or 'should'). Mapping will indicate spatially where specific mitigation measures are required.

## 7.3 Provision of Cultural Heritage Consultancy Services

Additional cultural heritage consultation services may be required as part of the CEMP and may be required in advance of the main construction contract. All cultural heritage works shall be carried out in accordance with the Code of Practice established by EirGrid and the Minister, and stated in the CEMP. All necessary licences and consents will be in place as necessary.

The programming and preparation of cultural heritage consultancy contracts, contract documents and the appointment of cultural heritage consultants and specialists has to be agreed with the project manager.

## 7.4 Cultural Heritage Consultancy Services – Pre-Construction

This stage represents all preliminary cultural heritage services and can include remote sensing surveys such as geophysical survey, topographical survey, underwater, dive and wade surveys, architectural heritage survey, metal detection survey and townland boundaries and lidar survey. This may include investigations such as targeted test excavation and environmental sampling as required by the CEMP.

The appointed cultural heritage consultant will be required to provide reports on the findings from all surveys at this stage and to ensure that all the appropriate licences and consents are in place prior to work commencing.



Once the investigation work has been completed, a report of the findings has to be submitted to the National Monuments Service and the National Museum of Ireland. The project manager will discuss the results with the relevant statutory authorities and consultant archaeologist to establish the appropriate method of preservation and preparation of associated mitigation works in accordance with the Code of Practice (NMS 2009).

## 7.5 During Construction

All survey preparation and excavation specification will be agreed with the statutory authorities and the client. The output requirements for the stage by the cultural heritage consultants are the provision of method statements as part of the licencing requirements for investigation and excavation services, which are based on the specifications provided by the client.

Excavation services involve the preservation by record through appropriate rescue excavation of any significant archaeological features or deposits discovered during the previous stages so as to mitigate impacts on archaeological remains that were discovered within the footprint of the project.



**Cereal Drying Kiln during Excavation, East-West Interconnector Project courtesy of Byrne Mullins & Associates**

The project manager has to ensure that all controls are in place for construction works so there is no inadvertent damage to cultural heritage assets; for example, the service diversion contract must not conflict with the archaeological services as described above or indeed with cultural heritage assets. Also storage and disposal of excavation materials cannot interfere with any cultural heritage asset. Similarly the project manager must ensure that archaeological investigations do not interfere with other disciplines.

Archaeological monitoring may be required in sensitive archaeological areas or areas of archaeological potential where excavation is necessary. Monitoring is to be carried out by a suitably qualified archaeologist.

In the event of archaeological sites and features being uncovered during monitoring of topsoil stripping, the project manager and onsite archaeologist will liaise with the statutory authorities to establish the preferred means of preservation.

On site exclusion zones around heritage assets and newly revealed features may also be necessary and all contractors should be made aware of why there is an exclusion zone in place and the value and significance of the heritage asset.

The project manager shall liaise with the onsite archaeologist to ensure that all commitments made in the EIS/ER and CEMP are adhered to during the construction contract.

Consultation with the authorities will be sought in order to resolve all matters concerning heritage assets.



Construction of wooden pole set support structure for Donegal 110 kV Project (Binbane – Letterkenny)

### 7.5.1 Uncovering a National Monument

In the event that a National Monument is uncovered during archaeological advance works or during the construction phase of the project, the consultant archaeologist shall liaise with the Project Manager and the National Monuments Service in order to protect the monument until formal decisions have been taken regarding its preservation, as per the National Monuments Acts 1930-2004, and subsequent amendments thereof.

### 7.5.2 Demolition of a National Monument

Statutory instrument (SI) 249 of 2012 (*European Union (Environmental Impact Assessment of Proposed Demolition of National Monuments) Regulations 2012*) has created an obligation for an EIA to be undertaken where the Minister's approval is sought under the National Monuments Acts for works that would result in the demolition of a National Monument.

### 7.5.3 Post-Excavation

Services at this stage of the process include all post-excavation analysis such as environmental dating, the production of detailed, technical and well-illustrated reports and provision of archival services arising out of the previous stages. This stage can also include the appropriate dissemination of the cultural heritage findings. In compliance with licencing requirements, archaeological findings have to be published in *Excavations* and a final report issued to the National Monuments Service and the National Museum of Ireland.

## 7.6 Operational Phase – Maintenance, Refurbishment & Upgrading

Surveys such as helicopter patrols, field walkovers and emergency patrols will establish the level of maintenance required to any given line. Refurbishment or upgrading (upgrading of an overhead electricity line) may be required during the life time of a transmission project. Issues arise in relation to cultural heritage when there is a cultural heritage asset in proximity to the proposed work.

Where structures require replacement during a line uprate or refurbishment, additional excavation may be required particularly where angle towers or structures require replacement. In general they are replaced within or adjacent to the footprint of the original structure. However, there could be potential for damage in and around the working area in sensitive cultural heritage locations.

During UGC maintenance and repair, work is carried out as much as possible in the cable joint bay locations. Cable routes are re-opened only when there is an incident on the line or a need to undertake a cable patrol. Maintenance of substations are generally carried out within the footprint of the station only.

Any works (including access tracks) that are located in a sensitive cultural heritage zone, or in proximity to a cultural heritage asset, will require monitoring by a suitably qualified archaeologist and consultation with the relevant authorities.

Historically, many transmission lines were established without the guidance of the EIA process. Work to maintain these OHLs and/or cables, or to bring them up to new industry standards may inadvertently have an adverse impact on a cultural heritage asset. The project manager should ensure that no inadvertent impact will occur to a heritage asset as a result of maintenance work, and should seek the advice of a cultural heritage consultant as necessary.

A centralised archive of all cultural heritage reports, experiences and methodologies for corridor management practices and transmission projects is important as a benchmark for applying lessons learnt to future projects.

## 8 References

CAAS Environmental Ltd on behalf of the Environmental Protection Agency (EPA), (2003) *Advice Notes on Current Practice (in Preparation of an Environmental Impact Statement)*. Dublin.

CIGRÉ (1999) *High voltage overhead lines: environmental concerns, procedures, impacts and mitigations*. CIGRÉ publication 147.

Cork County Council (2006) *Guidance notes for the appraisal of historic gardens, demesnes, estates and their setting*. Cork.

Council of Europe (1985) *Convention for the Protection of the Architectural Heritage of Europe* ('Granada'), Strasbourg.

Council of Europe (1992) *European Convention on the Protection of the Archaeological Heritage* (Valletta), Strasbourg.

Department of Arts, Heritage and the Gaeltacht (DoAHG) (2011) *Architectural Heritage Protection, Guidelines for Planning Authorities, Guidance on Part IV of the Planning and Development Act 2000*. Dublin. Stationery Office.

Department of Arts, Heritage, Gaeltacht and the Islands (DoAHGI) (1999) *Framework and Principles for the Protection of the Archaeological Heritage*, Dublin, Stationery Office.

Department of Environment, Heritage and Local Government (DoEHLG) (2003) *EIA, Guidance for Consent Authorities regarding Sub-Threshold Development*, Dublin.

EirGrid (2009) *Grid25 – A strategy for the development of Ireland's electricity grid for a sustainable and competitive future*.

EirGrid (2012) *Ecology guidelines for Electricity Transmission Projects – a standard approach to ecological impacts assessment of high voltage transmission projects*.

EirGrid (2012) *EirGrid Environmental Report for Grid25 Implementation Programme 2011-2016*.

EirGrid (2014) *Evidence Based Study for High Voltage Electricity Transmission Projects in Ireland – Cultural Heritage*. Report by Courtney Deery Heritage Consultancy Ltd for EirGrid on behalf of RPS Group.

English Heritage (now Historic England) (2005) *Wind Energy and the Historic Environment*, London: English Heritage.

English Heritage (2011) *The Setting of Heritage Assets*, English Heritage Guidance, London.

English Heritage (March 2015) *Historic Environment Good Practice Advice in Planning Note 3: The Setting of Heritage Assets*

EPA (2002) *Guidelines on the information to be contained in Environmental Impact Statements*, Wexford: Environmental Protection Agency.

European Commission (2001) *Guidance on EIA – EIS Review*.

ICOMOS (2005) *Xi'an Declaration on the Conservation of the Setting of Heritage Structures, Sites and Areas*. Paris: International Council on Monuments and Sites.

Lambrick, G. and Hind, J. (2006) *Review of Cultural Heritage Coverage in Environmental Impact Assessments*, Planarch 2.

McCarthy J. in the case of *Attorney General (McGarry) v Sligo County Council* (1991) 1 I.R. 99. (In relation to a proposal to operate a refuse dump within Carrowmore megalithic cemetery and also on the concept of a 'fallow area').

NMS (2009) Code of Practice between the Minister of the Environment, Heritage and Local Government and EirGrid in relation to Archaeological Heritage. Dublin National Monument Service.

NMS (2009) Code of Practice between the Minister of the Environment, Heritage and Local Government and ESB Networks in relation to Archaeological Heritage. Dublin National Monument Service.

NRA, (2005a) *Guidelines for the Assessment of Archaeological Heritage Impacts of National Road Schemes*. Dublin: National Roads Authority.

NRA, (2005b) *Guidelines for the Assessment of Architectural Heritage Impacts of National Road Schemes*. Dublin: National Roads Authority.

NRA (2010) *Project Management Guidelines*. Dublin: National Roads Authority.

### **World Wide Web**

Information in relation to estate houses and demesnes can be examined on this website: <http://www.buildingsofireland.com/Surveys/Gardens/>

Archaeological excavations can be reviewed on this website: [www.excavations.ie](http://www.excavations.ie)

The location of Recorded and Registered Monuments can be examined on this website: [www.archaeology.ie](http://www.archaeology.ie)

Townland names and place-names can be reviewed on this website: [www.logainm.ie](http://www.logainm.ie)

Ordnance survey mapping and aerial photographs can be browsed on this website: [www.osi.ie](http://www.osi.ie)

Information in relation to archaeological excavations on recent road schemes can be accessed through this website: [www.nra.ie](http://www.nra.ie)

Information in relation to demesnes can be reviewed on this web site: [www.landedestates.ie](http://www.landedestates.ie)

Information in relation to aerial photography, recorded monuments and NIAH structures can be reviewed on [www.myplan.ie](http://www.myplan.ie)

Relevant county councils web sites were reviewed in relation to archaeology, architectural heritage and cultural heritage information

## APPENDIX 1 GLOSSARY OF TERMS

### **Aerial Survey (Aerial Reconnaissance)**

A survey technique used for searching for unrecorded or recorded sites and features from the air. This is a successful method to search for patterns or changes in soil colour (soil marks) or plant density (cropmarks) that may not be visible to a person walking on the ground.

### **An Bord Pleanála**

An Bord Pleanála is responsible for the determination of appeals and certain other matters under the Planning and Development Act, 2000 (as amended) and determination of applications for strategic infrastructure development including electrical transmission projects. It is also responsible for dealing with proposals for the compulsory acquisition of land by local authorities and others under various enactments. The Board also has functions to determine appeals under Water and Air Pollution Acts and the Building Control Act.

### **Archaeology**

The scientific study of past societies through the physical material and environmental remains they leave behind. It investigates their houses, settlements and tombs and everyday implements. It seeks to understand the landscape, vegetation and climate of previous times as they affected, and were affected by, past peoples.

### **Archaeological Excavation**

The scientific process of systematically digging up, recording, and removing artefacts and other features from an archaeological site in order to analyse and predict past human behaviour.

### **Archaeological Monitoring**

Involves *'an archaeologist being present in the course of the carrying-out of the development works (which may include conservation works), so as to identify and protect archaeological deposits, features or objects which may be uncovered or otherwise affected by the works'* (DAHGI 1999a, 28).

### **Archaeological Test Excavation**

*'Test excavation is that form of archaeological excavation where the purpose is to establish the nature and extent of archaeological deposits and features present in a location which it is proposed to develop (though not normally to fully investigate those deposits or features) and allow an assessment to be made of the archaeological impact of the proposed development. It may also be referred to as archaeological testing'. Test trenching usually involves 'the excavation of long narrow slit trenches to achieve a cross-sectional transect or group of transects across a site in which archaeological features and deposits may be noted.* (DAHGI 1999a, 27).

### **Architectural Conservation Areas**

Architectural Conservation Areas (ACA) are places, groups of structures or townscapes that are of special architectural, historical, archaeological, artistic, cultural scientific, social or technical interest/value or contribute to the appreciation of Protected Structures. ACAs and candidate ACAs are listed in every County Development Plan and Town Development Plan used for consultation purposes.

### **Architectural Heritage**

Structures and buildings which are of architectural, historical, archaeological, artistic, cultural, scientific, social or technical interest.

### **Artefact**

A portable object manufactured, modified, or used by humans

### **Attendant Grounds**

Lands outside the *curtilage* of the structure but which are associated with the structure and are intrinsic to its function, setting and/or appreciation. It can include land originally within its curtilage, which through change of ownership or subdivision of the site has become alienated from the building.

### **Construction Environmental Management Plan (CEMP)**

A plan that brings together all suggested mitigation and monitoring proposals in order to avoid, reduce or where possible, remedy significant adverse effects identified during the EIS process prior to development consent being granted. Although not required under the present EIA legislation, the

preparation of a CEMP is considered good practice and should be considered for all high voltage electricity transmission projects.

### **Cultural Heritage**

Cultural heritage is a broad and open term which has now come to include a wide range of tangible and intangible cultural considerations that are linked to and bound up in cultural memory and associations, belief, traditions, past knowledge, traditional and arcane practices, craft and building skills, and oral tradition of local populations. It encompasses aspects of archaeology, architecture, history, landscape and garden design, folklore and tradition and topography. Cultural heritage is expressed in the physical landscape in numerous often interrelated ways.

### **Cultural Heritage Assets**

For the purpose of these Guidelines, cultural heritage, which comprises the many facets of archaeological heritage, architectural heritage and cultural heritage are collectively described as cultural heritage assets.

### **Curtilage**

By definition, a protected structure includes the land lying within the curtilage of the protected structure and other structures within that curtilage and their interiors. The notion of curtilage is not defined by legislation, but for the purposes of the 'Architectural Heritage Protection Guidelines' (2004) by the Department of the Environment Heritage and Local Government it can be taken to be the parcel of land immediately associated with that structure and which is (or was) in use for the purposes of the structure.

### **Desk Study**

The survey and analysis of published and other existing information relating to an area, site or structure.

### **EirGrid Evidence Based Studies –Cultural Heritage**

Commissioned by EirGrid the cultural heritage evidence based study examined the actual effects of the construction, existence and operation of high voltage transmission projects in Ireland on archaeological, architectural and cultural heritage assets. The study forms part of a suite of multidisciplinary scientific studies and provide actual evidence of environmental impact and will inform future guidance in terms of planning and design for each discipline examined.

### **EirGrid Project Development and Consultation Road Map**

A five stage structured framework for project development and consultation for the development of large transmission projects through the public planning process, to construction. The structured framework ensures that planning, environmental and community issues are identified and addressed from the earliest stage, helping EirGrid make fully-informed decisions during the development of a project.

### **Environmental Impact Assessment (EIA)**

The process of examining the environmental effects of development / projects.

### **Environmental Impact Statement (EIS)**

Report presenting data and conclusions to assist the competent authority in the environmental impact assessment process. Archaeological, Architectural and Cultural Heritage is a chapter within this statement.

### **Field Walkover Survey**

A visual inspection of a survey area to identify and locate any archaeological sites and monuments that survives as upstanding earthworks or historic structures. The survey gathers information to establish the extent, nature, character, condition, quality and date of the surviving archaeological, historical and cultural heritage features within the survey area (as far as is possible). It assists in establishing the functional relationships between any identified archaeological and historical features and the impact of a transmission infrastructure on it. It also provides information for appropriate further work to mitigate any potential impact.

**Geophysical survey**

A non-invasive survey technique used to find buried archaeological remains. A variety of scientific instruments are used to measure small changes in the magnetic and electrical properties of the earth which can indicate where archaeology is located beneath the ground. Techniques such as magnetometry, radar, resistivity, and conductivity are commonly used.

**Global Positioning System (GPS)**

An instrument that determines the location of features by triangulation, using data from orbiting satellites.

**Historic Designed Landscape**

A landscape significant as a design or work of art, which was consciously designed and laid out either by a professional or amateur according to a recognized style or tradition; has a historical association with a significant person, trend or movement in landscape gardening or architecture, or a significant relationship to the theory or practice of landscape architecture.

**Historic Garden and Designed Landscape Survey**

This National Inventory of Architectural Heritage survey of the DAHG is a preliminary one, based on paper study using historic map sources and aerial photography to identify and list gardens and demesnes which. The sites usually, but not always, associated with Protected Structures and therefore do not always have statutory protection. ([www.buildingsofireland.ie/survey/gardens](http://www.buildingsofireland.ie/survey/gardens))

**Historic Landscapes**

Areas of land, as perceived by people, whose character is the result of the interaction of natural with human factors, and any area adjacent to such historic landscape which assists or supports in giving such landscape its character, value or integrity or in maintaining the same.

**Historic Landscape Characterisation**

Historic Landscape Characterisation (HLC) is concerned with identifying the contribution of the past to the landscape as it exists in the present

**Inventory**

A list of cultural heritage assets within a given area.

**Landscape Character Assessment**

Landscape character is the distinctive, recognisable and consistent pattern of elements that make one landscape different from another. Landscape Character Assessment (LCA) describes landscapes in terms of their character in an objective way. This is used to inform decision making in relation to the protection of the environment, natural resources and heritage; it can be used to monitor change and it can be used to guide development.

**Mitigation**

Measures taken to reduce adverse impacts e.g. modifications or additions to the design of the development, such as screening, preservation in situ or full or partial excavation.

**National Inventory of Architectural Heritage**

The National Inventory of Architectural Heritage (NIAH) is a unit within the Heritage and Planning Division of the DAHG. It was placed on a statutory footing by the Architectural Heritage (National Inventory) and Historic Monuments Act 1999. The NIAH's role is to identify record and evaluate the post-1700 architectural heritage of Ireland. It aims to promote the appreciation of, and contributes to the protection of, the built heritage by systematically recording a representative sample of that built heritage on a nationwide basis. The surveys provide the basis for the recommendations of the Minister to the planning authorities for the inclusion of particular structures in their Record of Protected Structures (RPS).

**National Monuments (NM)**

The term 'national monument' as defined in Section 2 of the National Monuments Act (1930) means a monument *'the preservation of which is a matter of national importance by reason of the historical, architectural, traditional, artistic or archaeological interest attaching thereto...'* National monuments in State care include those which are in the ownership or guardianship of the Minister for Arts, Heritage and the Gaeltacht. Section 5 of the National Monuments Act (1930) allows owners of other national



monuments to appoint the Minister for the Arts, Heritage and the Gaeltacht or the relevant local authority as guardian of such monuments, subject to their consent. This means in effect that while the property of such a monument remains vested in the owner, its maintenance and upkeep are the responsibility of the State.

### **Non-Renewable Resource**

A resource that cannot be replaced

### **Preservation In-Situ**

Preservation in-situ is the actual physical preservation of archaeological sites and monuments, including archaeological deposits, features and structures. There should always be a presumption in favour of avoiding developmental impacts on the archaeological heritage. *'Preservation in-situ must always be the first option to be considered rather than preservation by record in order to allow development to proceed and, preservation in-situ must also be presumed to be the preferred option.'* (Framework and Principles for the Protection of the Archaeological Heritage, 1999)

### **Preservation Order (PO)**

Where it appears to the Minister that a monument, considered to be a national monument, is in danger or is actually being destroyed or falling into decay the minister may by preservation order or temporary preservation order, undertake the preservation of the monument. A temporary preservation order will remain in force for six months and then expire; however it is an indication of additional sites that are considered as being national monuments.

### **Record of Monuments and Places (RMP)**

The Record of Monument and Places (RMP) is a statutory list of all known archaeological monuments provided for in the National Monuments Acts. There are over 120,000 Recorded Monuments included in the RMP. The RMP consists of a published county-by-county set of Ordnance Survey maps on which monuments are marked by a circle and an accompanying book which specifies the type of monuments.

### **Register of Historic Monuments (RHM)**

The Register of Historic Monuments was established under Section 5 of the National Monuments Act 1987. This list consists of monuments which are known to the Minister and which in the Minister's opinion should be so entered in the Register. Section 5(8) of the 1987 Act provides that where the owner or occupier (not being the Minister) of a historic monument or archaeological area entered in the Register, or any other person, proposes to carry out, or cause or permit the carrying out of, any work, at or in relation to such a monument or area then he or she shall give notice in writing of the proposal to the Minister and shall not, except in the case of urgent necessity and with the consent of the Minister, commence the work until two months after the giving of the notice.

### **Protected Structures**

A protected structure is a structure that is considered to be of 'special interest', which is broadly defined by the Planning and Development Act, 2000 as structures of architectural, historical, archaeological, artistic, cultural, scientific, social or technical point of interest. The 2000 Act requires each planning authority to compile and maintain a Record of Protected Structures (RPS).

### **Post-Excavation**

Services at this stage of the process includes all post-excavation analysis such as environmental dating, the production of detailed, technical and well-illustrated reports and provision of archival services arising out of the previous stages. This stage can also include the appropriate dissemination of the cultural heritage findings.

### **Record of Protected Structures (RPS)**

The RPS is a mechanism for the statutory protection of the architectural heritage and is listed in every County Development Plan and Town Development Plan.

### **UNESCO World Heritage Sites**

World Heritage sites are places that are important to and belong to everyone no matter where they live. They have a recognised universal value that goes beyond the value they hold for a particular nation. The World Heritage Convention was adopted by the UNESCO (United Nations Educational, Scientific and Cultural Organisation) General Conference in 1972. Ireland ratified the Convention,

including Ireland in 1991. The Republic of Ireland currently has two properties on the World Heritage List Brú: Na Bóinne and Skellig Michael.

### **UNESCO World Heritage Sites Tentative List**

A Tentative List is an inventory of those properties which a country intends to consider for nomination to the World Heritage List. There are currently seven areas/ groups of sites on the Republic of Irelands Tentative List (dated March 2010).

### **Vantage Survey**

A broad and expedient survey from a vehicle (or vantage point), it is used prior to a detailed field walkover survey to record initial observations of a large landscape and taking note of its general characteristics.

## APPENDIX 2 GLOSSARY OF IMPACTS (adapted from EPA Guidelines 2002 and NRA Guidelines 2005)

The impacts on archaeological, architectural, and cultural heritage are generally categorised as either being direct, indirect or cumulative or as having no predicted impact. Direct effects would be physical effects including disturbance of or damage to sites and features of cultural heritage interest; there could also be a direct impact on the setting of a feature of significance.

A **direct impact** occurs when a cultural heritage asset is partly or wholly located within the proposed development area and entails the removal of part, or the entire asset.

**Indirect impacts** may be caused due to the close proximity of a development to a cultural heritage asset. Mitigation strategies and knowledge of detail design can often ameliorate any adverse indirect impact. Indirect impacts may include severance of linked features, degradation of setting and amenity or provide a visual intrusion.

**No predicted impact** occurs when the proposed development does not adversely or positively affect an archaeological site.

The impacts of the proposed development on the archaeological environment are first assessed in terms of their quality i.e. positive, negative or neutral. Each level of impact apart from profound can have a positive or negative effect. A positive effect on cultural heritage asset might be that because of development the feature/site becomes more accessible, although management of interested sightseers is an important aspect to the continuing integrity of the feature.

**Positive Impact** A change that improves or enhances the setting of cultural heritage asset.

**Negative Impact** A change that will detract from or permanently remove a cultural heritage asset from the landscape.

**Neutral Impact** A change that does not affect the cultural heritage asset.

A significance rating for the impact on a cultural heritage asset is then given i.e. slight, moderate, significant or profound, which describes the scale or severity of the impact and can be temporary (short, medium and long term) or permanent. Any physical impact on a recorded protected site is regarded as a profound impact.

**Profound** – Applies where mitigation would be unlikely to remove adverse effects. Reserved for adverse, negative effects only. These effects are generally, but not exclusively, associated with sites and features of national or regional importance. They arise where a cultural heritage asset is completely and irreversibly destroyed by a proposed development.

**Significant** – An impact which, by its magnitude, duration or intensity alters an important aspect of the environment (EPA Guidelines for EISs). An impact like this would be where the majority of the cultural heritage asset would be permanently impacted upon leading to a loss of character, integrity and historical or archaeological data about the asset.

**Moderate** – A moderate direct impact arises where a change to cultural heritage asset is proposed which though noticeable, is not such that the archaeological, architectural or historical integrity of the structure is compromised and which is reversible. This arises where an historic structure or archaeological feature can be incorporated into a modern day development without damage and that all procedures used to facilitate this are reversible.

**Slight** – An impact which causes changes in the character of the environment which are not significant or profound and do not directly impact or affect a cultural heritage asset.

**Imperceptible Impact** – An impact capable of measurement but without noticeable consequences on a cultural heritage asset

### Duration of Impacts

|                           |  |
|---------------------------|--|
| <i>Temporary Impact</i>   | Impact lasting for one year or less.   |
| <i>Short-term Impacts</i> | Impact lasting one to seven years.     |
| <i>Medium-term Impact</i> | Impact lasting seven to fifteen years. |
| <i>Long-term Impact</i>   | Impact lasting fifteen to sixty years. |
| <i>Permanent Impact</i>   | Impact lasting over sixty years.       |

### Types of Impacts

**Cumulative Impact** – The addition of many small impacts to create one larger, more significant, impact.

**'Do Nothing Impact'** – The environment as it would be in the future should no development of any kind be carried out.

**Indeterminable Impact** – When the full consequences of a change in the environment cannot be described.

**Irreversible Impact** – When the character, distinctiveness, diversity or reproductive capacity of an environment is permanently lost.

**Residual Impact** – The degree of environmental change that will occur after the proposed mitigation measures have taken effect.

**'Worst case' Impact** – The impacts arising from a development in the case where mitigation measure substantially fail

**Secondary Impact** – Impacts arising as a consequence of the existence of the principal project

## **APPENDIX 3            STATUTORY CONSULTEES**

Heritage Officer  
An Taisce  
National Trust for Ireland  
Tailors Hall  
Dublin 8

Manager Environment and Planning  
Fáilte Ireland  
88-95 Amiens Street  
Dublin 1

Planning and Development Officer  
The Heritage Council  
Áras na hOidhreachta  
Church Lane  
Kilkenny

The Manager  
Development Applications Unit  
Department of Arts, Heritage and the Gaeltacht  
Newtown Road  
Wexford  
Planning Department  
Relevant County Council

Relevant County Council Heritage Officer  
Relevant County Council

## APPENDIX 4 RANGE OF HERITAGE ASSETS, ENVIRONMENTS & LANDSCAPES

### Cultural Heritage Landscapes and Assets

The following table shows examples of the range of cultural heritage landscapes and assets that may be subject to impact during a transmission project.

| Landscapes  | Time periods  | Cultural Heritage Assets Variables  |
|---|---|---|
| Landscapes: Urban, farmed, forested, woodland, upland, mountainous, raised, milled, blanket and raised peatlands, river valleys, wetland and lowland. | Date Range: Mesolithic, Neolithic, Bronze Age, Iron Age, Early Medieval, Medieval, Viking, Anglo Norman, Late Medieval, Early Modern. | <i>Cultural heritage designation</i><br>World Heritage Sites and Candidate World Heritage Sites, National Monuments, Record of Monuments and Places, Record of Protected Structures, National Inventory of Architectural Heritage.  |
|   |   | <i>Visibility in the landscape</i><br>Large scale, well preserved and upstanding monuments and structures to low visible remains and non-visible remains. The inter-visibility, setting, aesthetics and amenity value of monuments will be explored.  |
|   |   | <i>Archaeological site types</i><br>A non-exhaustive list of site types includes Mesolithic fish traps, shell middens, cave sites, Neolithic field systems, house sites, standing stones, stone circles, stone alignments, megalithic tombs, rock art, promontory forts, trackways, ringforts and enclosures, souterrains, crannogs, children's burial grounds, ecclesiastical remains, medieval field patterns, monastic sites, flat cemetery sites, barrows, moated sites, motte and bailey sites, castles, fortified houses, church and graveyard sites, battlefields, mills, industrial archaeology sites, artefact scatters, etc.  |
|   |   | <i>Historic/Cultural landscapes</i><br>Documented historic landscapes such as the Curragh, The Burren, Céide Fields, Carrowmore Complex, Bend of the Boyne/ Brú na Bóinne, Battle of the Boyne, Phoenix Park. GAA pitches, horse fairs, skirmish sites, sites associated with placenames, pilgrim's ways/pattern-day paths. Vernacular structures, clachans, deserted medieval settlements  |
|   |   | <i>Demesne landscapes</i><br>Formal and walled gardens, boundary walls, vistas, avenues and views, managed woodland, fox coverts, deer parks, estate house and outbuildings, gate lodges, ponds and canals. Strokestown House Park, Kilruddery House, Castletown House, etc.  |
|   |   | <i>Areas of potential</i><br>Buried relict landscapes with no surface visibility, for example the Céide Fields in County Mayo. Sites of low visibility that form cluster patterns, for example a number of fulachta fiadh and barrow sites. Sites with a temporal relationship, sites that are inter-visible. Landscapes that have undergone limited topographic and cartographic review, where there is a distinct possibility for upstanding and below ground remains to exist, for example the rough mountainous areas of Kerry and Donegal and boglands of County Mayo. Unknown sites that are associated with known and recorded monuments and whose existence can only be established through field survey, for example a bawn surrounding an upstanding castle site or a burial ground associated with later features such as workhouses. Areas where it is acknowledged that monuments occupy a 'space' but where their fundamental connection and function still have to be examined and understood, for example, the rock art sites of Derrynablaha, County Kerry, or field patterns, walls and boundaries. |

## Archaeological Heritage

The following table shows examples of the range of archaeological heritage sites and features that may be subject to impact during a transmission project.

| Environment   | Illustrative archaeological sites   | Potential Impacts   |
|---|---|---|
| Wetland environments,<br>Bog ( <i>Blanket and raised</i> )<br>Peatlands               | Pre-bog archaeology from the Neolithic onwards, in the form of field systems, artefacts, settlement and ritual sites. High occurrence of organic material. Toghers/trackways votive deposits Fulacht fiadh, burnt mounds/spreads, water management activity.  | <ul style="list-style-type: none"> <li>• A direct physical impact of a tower/pole set on an upstanding/ subsurface site/monument removing part or all of the site/monument</li> </ul>   |
| Underwater /Maritime archaeology<br>Riverine,<br>Lacustrine,<br>Estuarine,<br>Coastal | Stray finds, shipwrecks, settlement/ industrial riverside activity from prehistoric to eighteenth century, crannogs, Industrial archaeology, river crossing, fish traps. Coastal sites: midden sites, piers harbours, submerged landscapes oyster ponds jetties shipwrecks.   | <ul style="list-style-type: none"> <li>• Severance of linked features, or inter-visibility between sites, important views to and from site or structure and between it includes other sites/monuments and sometimes natural landmarks such as mountains and lakes.</li> </ul> |
| Mountain/uplands  | Previously undisturbed megalithic structures. Hut sites relict field systems (prehistoric to 18 <sup>th</sup> century) comprising boundaries field systems/ patterns. Hill top enclosures. Caves and rockshelters. The potential for undiscovered remains is high due to the undisturbed nature of such landscapes.   | <ul style="list-style-type: none"> <li>• Changes to the setting of a monument.</li> <li>• A significant visual intrusion</li> </ul>   |
| Gravel Ridges/esker   | Boundaries, burials, settlement activity.   | <ul style="list-style-type: none"> <li>• Loss of amenity, especially where the site/monument is open to the public</li> </ul>   |
| Improved pasture  | Flint scatters, ploughed out subsurface archaeological sites, enclosures (ringfort, barrows etc.). Archaeological complexes such as ecclesiastical sites, castle sites, walled towns, deserted medieval settlements, shrunken villages. Settlements, fields, route ways. Cemeteries. Ritual sites, burials, ritual monuments (megalithic tombs, standing stones). |   |

Archaeological sites occur in every type of terrain; upland, lowland, estuarine, riverine, coastal, lacustrine, agricultural land, raised and blanket bogland. In the landscape, monuments can have high visibility, being easily recognisable and distinctive in character; low visibility eg cropmarks indicating ringforts and burial enclosures and might only be visible as low earthworks in the field or in aerial photography; or have no visibility where extensive archaeological deposits and features survive entirely below ground. In addition there are entire landscapes that lie beneath bogs, or souterrains or sites in caves.

## Architectural Heritage

The following table shows examples of the range of architectural heritage sites and features that may be subject to impact during a transmission project.

| Structure/features                           | Illustrative examples  | Potential Impacts  |
|--|--|--|
| Country Estates                              | Country Houses of various sizes. Demesnes lands and associated landscapes containing principal buildings and out buildings, access drives, walks and avenues, gardens, parkland enclosures, deer parks and can sometimes incorporate canals and lakes and rivers – they can also contain archaeological features such as ringforts which were used as a feature in the landscape) walled gardens, woodlands, formal gardens, vistas, lake and rivers, follies, water features, planted avenues and earthworks. | <ul style="list-style-type: none"> <li>• A direct impact on the attendant grounds and/or curtilage of a structure.</li> <li>• A significant visual intrusion</li> <li>• Severance of associated features such as a demesne house and its associated gardens, outbuilding or lodges.</li> </ul> |
| Relict Demesne                               | These will range from being substantially intact, to sites that have lost some integrity to sites that may be partially derelict/destroyed some with only the buildings surviving or perhaps just the garden. Some may be gone entirely and may only be of historic interest.  | <ul style="list-style-type: none"> <li>• Important views to and from a structure and between it includes man-made landmarks and sometimes natural landmarks such as mountains and lakes should all be taken into account.</li> </ul>   |
| Designed Landscapes                          | Urban squares, parks demesnes or landscaped estates. Designed gardens containing notable plant collections, have a particular significance to garden designer/history integral to the setting of an historic building.   | <ul style="list-style-type: none"> <li>• Changes in setting of a built heritage structure.</li> </ul>  |
| Vernacular Structures /Traditional Buildings | Domestic houses, cottages. Otherwise ordinary structures may be distinctive and have special social interest (e.g., thatched roofing and plan forms that may be direct-entry, lobby-entry, doors opposite one another, bed outshots etc). Agricultural, commercial buildings and farm complexes.   | <ul style="list-style-type: none"> <li>• Loss of amenity, especially where the historic house, parks or gardens are open to the public.</li> </ul>   |
| Industrial Buildings                         | Mining heritage sites, milling sites, breweries, distilleries, canals and canal structures.  |  |
| Military Sites                               | Martello towers, barracks, pillboxes or sentry-boxes.  |  |
| Monuments                                    | Stone castles, churches, abbeys etc.   |  |
| Maritime                                     | Harbours, piers, quay walls, lighthouses, coastguard stations and signal (semaphore) towers  |  |
| Ecclesiastical                               | Churches, chapels, graveyards and meeting houses.  |  |
| Social/Civic/Pleasure /Commemorative         | Village halls, cinemas, dance halls, libraries, health and welfare (former workhouses and fever hospital buildings etc.), court houses, schools memorials, gravestones/tombs, bench marks.   |  |
| Transport/ Street Furniture                  | Railways and associated structures, bridges, signal boxes, footbridges, former toll houses, milestones, boundary walls, lamp posts, post boxes, telephone kiosks and animal drinking troughs.  |  |



## Cultural Heritage

The following table shows examples of the range of cultural heritage sites and features that may be subject to impact during a transmission project.

|  | <b>Illustrative examples</b>   | <b>Potential Impacts</b>  |
|--|--|---|
| Historic Places  | Pre-famine settlements clachans, relict field systems, nucleated clachan settlement and associated rundle system. Townland boundaries/ field boundaries, deserted villages.  | <ul style="list-style-type: none"> <li>• A direct impact on the attendant grounds and/or curtilage of a structure.</li> <li>• A significant visual intrusion</li> <li>• Severance of associated features</li> <li>• Removal of a tradition</li> </ul> |
| Religious Sites  | Holy wells/trees/bushes, mass rocks, coffin stones, children's burial grounds routes taken for religious processions or pattern days.  |   |
| Intangible (areas with cultural significance may not present physical remains) | Language, inherited tradition, folklore<br>Places associated with significant events or person that have played an important part in the locality's or national history (e.g. battlefield sites), community traditions (games, races, dancing at cross roads), established sporting activities and traditional country pursuits<br>Places with well documented association with a person, group of people or organisation.<br>Significant in the evolution or pattern of the history of the local area e.g. Mining heritage sites. |   |

## APPENDIX 5 EIRGRID RECORDING FORM & CHECKLISTS

**Location:**

|                     |                 |        |        |                    |                   |              |  |
|---------------------|-----------------|--------|--------|--------------------|-------------------|--------------|--|
| <b>County:</b>      |                 |        |        | <b>Townland/s:</b> |                   |              |  |
| <b>Technology</b>   | <b>Overhead</b> |        |        | <b>Underground</b> | <b>Substation</b> | <b>Other</b> |  |
|                     | 110 kV          | 220 kV | 400 kV |                    |                   |              |  |
| <b>Project name</b> |                 |        |        |                    |                   |              |  |

**Monument/structure**

|                       |  |  |  |
|-----------------------|--|--|--|
| <b>Unique ID #</b>    |  | <b>RMP/SMR/RPS Ref. #</b>                    |  |
| <b>Type of asset:</b> |  | <b>Monument/ Building Type &amp; Period:</b> |  |
| <b>Townland:</b>      |  | <b>National Grid Ref:</b>                    |  |

**Monument/structure:**

Description of the heritage asset and its setting:

Description of the Cultural Heritage landscape and areas of potential:

**Distance to cultural heritage asset from line and/or structure:**

|   |  |                           |                         |
|---|--|---------------------------|-------------------------|
| <b>Mainline/structure Ref:</b>  |  | <b>From Tower #_____:</b> | <b>To Tower #_____:</b> |
| <b>Development Description and Location in relation to the Cultural Heritage Asset:</b> |  |                           |                         |
|   |  |                           |                         |

**Assessment of Impact:**

**Unique ID #:** \_\_\_\_\_

**Description of impact on the heritage asset (including setting).** Direct. Indirect. Cumulative. No Impact .

**Significance of Impact:** Profound, Significant. Moderate. Slight. Imperceptible

**Other Impacts:** e.g. agricultural, quarrying, forestry, development etc.

**Further Comments:**

Aerial Photography:

Historic Mapping:

**Sketch (Proximity to other features):**

**Indicate North**

**Compiled by:**

**Date of Site Visit:**

**Checklist of potential attributes for assessing the setting of a heritage asset  
(English Heritage 2011)**

***Physical surrounding of the asset (evidential and historic values)***

Topography  
 Other heritage assets (including buildings, structures, landscapes, areas or archaeological remains)  
 Definition, scale and 'grain' of surrounding streetscape, landscape and spaces  
 Formal design  
 Land use  
 Green space, trees and vegetation  
 Openness, enclosure and boundaries  
 Function relationships (inter-relationship with other sites)  
 Degree of change over time  
 Integrity (intactness)  
 Issues such as soil chemistry and hydrology

***Experience of the asset (aesthetic values)***

Surrounding landscape or townscape character  
 Views from, towards, through, across and including the asset  
 Visual dominance, prominence or role as focal point  
 Intentional inter-visibility with other historic and natural features  
 Noise, vibration and other pollutants or nuisances  
 Tranquillity, remoteness and 'wildness'  
 Sense of enclosure, seclusion, intimacy or privacy  
 Dynamism and activity  
 Accessibility, permeability and patterns of movement  
 Degree of interpretation or promotion to the public  
 The rarity of comparable survivals of setting

***Associative Attributes of the asset (communal heritage value)***

Associative relationships between heritage assets  
 Trails, visitor amenity areas and guided sites  
 Cultural associations  
 Celebrated artistic representations  
 Traditions

**Impact on Setting Checklist**
**Location and Siting of the transmission project**

- Location of structures in relation to the heritage asset (N, S, E, W)
- Orientation of the overhead transmission line in relation to the asset
- Proximity to/from asset (i.e. to the structure, OHL, substation etc.)
- Extent of the infrastructure
- Position in relation to landform (e.g. in a valley, on a hilltop, at the edge of field)
- Degree to which location will physically or visually isolate asset
- Cumulative (e.g. wirescape or other developments)
- Position in relation to key views associated with the heritage asset

**Form and Appearance of the transmission project**

- Prominence, dominance or conspicuousness
- Competition with or distraction from the asset
- Dimension, scale and massing
- Proportions
- Visual permeability (extent to which it can be seen through)
- Materials (texture, colour, reflectiveness)
- Structure / substation design
- Diurnal or seasonal change (e.g. night-time appearance/ vegetation cover)

**Other Effects**

- Change to built surroundings and spaces
- Change to skyline
- Change to general character
- Changes to public access, use of amenity
- Changes to land use, land cover, tree cover
- Changes to archaeological context, soil chemistry or hydrology
- Changes to communications/ accessibility/permeability

**Setting Assessment**

- Asset Type and Ref No.:
- Cultural Heritage Asset Status:
- Impacted by:

**Impact on Setting – Comment Box**

Compiled by:

Date:

## APPENDIX 6 TYPICAL OVERHEAD ELECTRICITY STRUCTURES 110 kV, 220 kV & 400 kV

Note: dimensions are indicative only

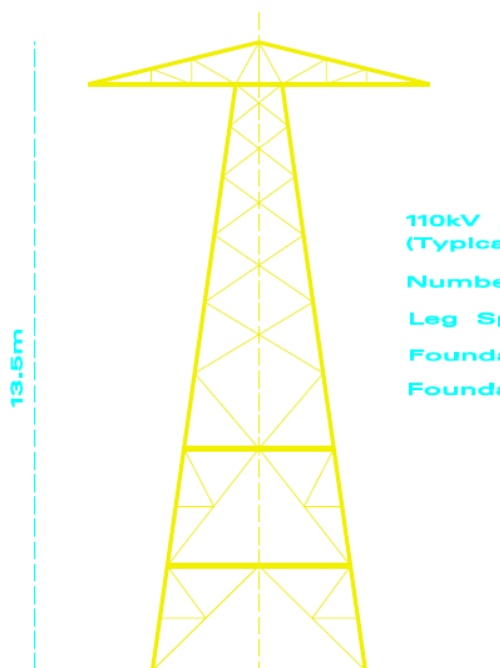
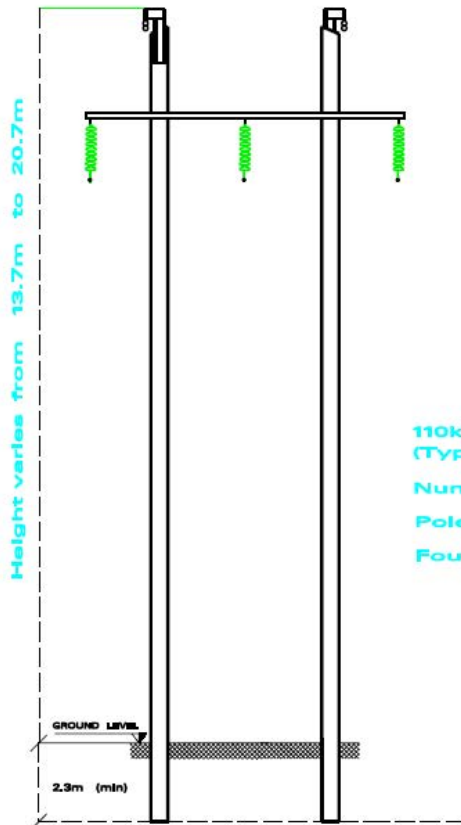

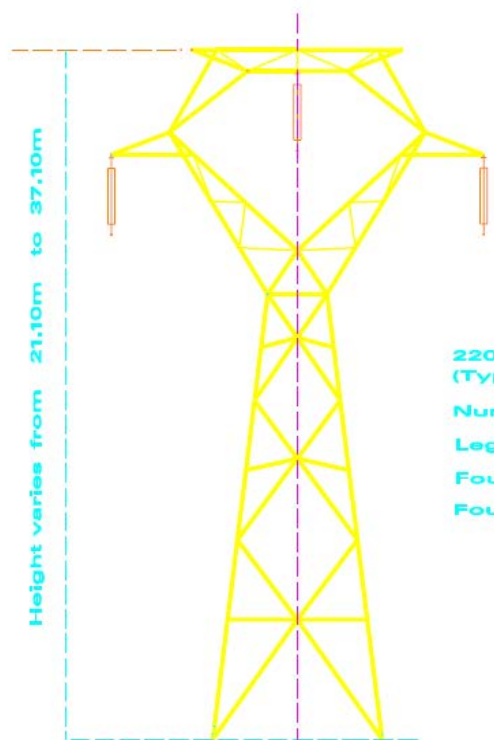

220kV Intermediate Tower  
(Typical Dimensions)

Number of Foundations = 4

Leg Spacing = 6.3m

Foundation Depth = 3m

Foundation Width = 2.5m x 2.5m

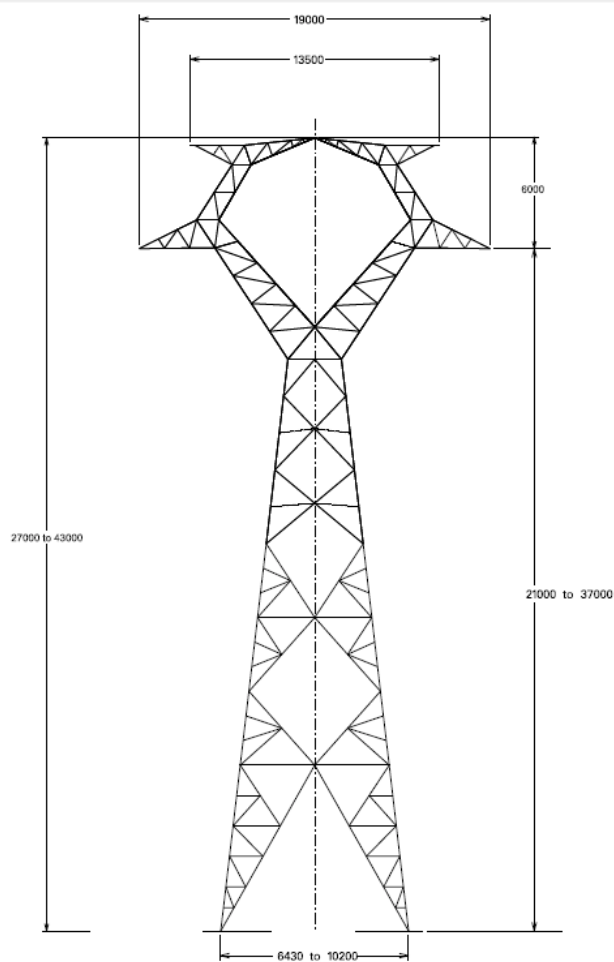

400 kV intermediate tower

## APPENDIX 7 CABLING STRUCTURES

Note: dimensions are indicative only

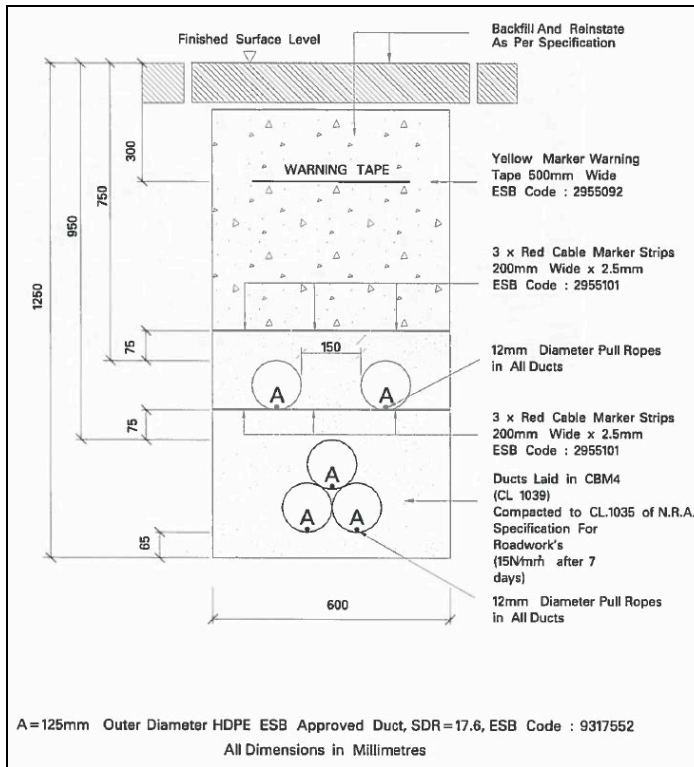

### Trench cross section of a 110 kV single circuit trefoil duct formation

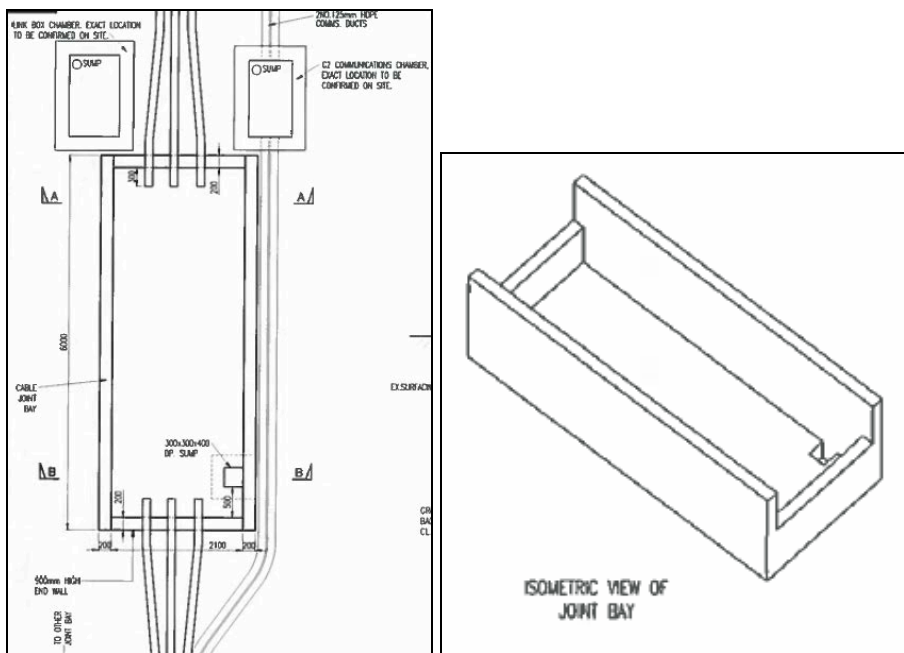

Typical plan of a joint bay in road and an isometric view



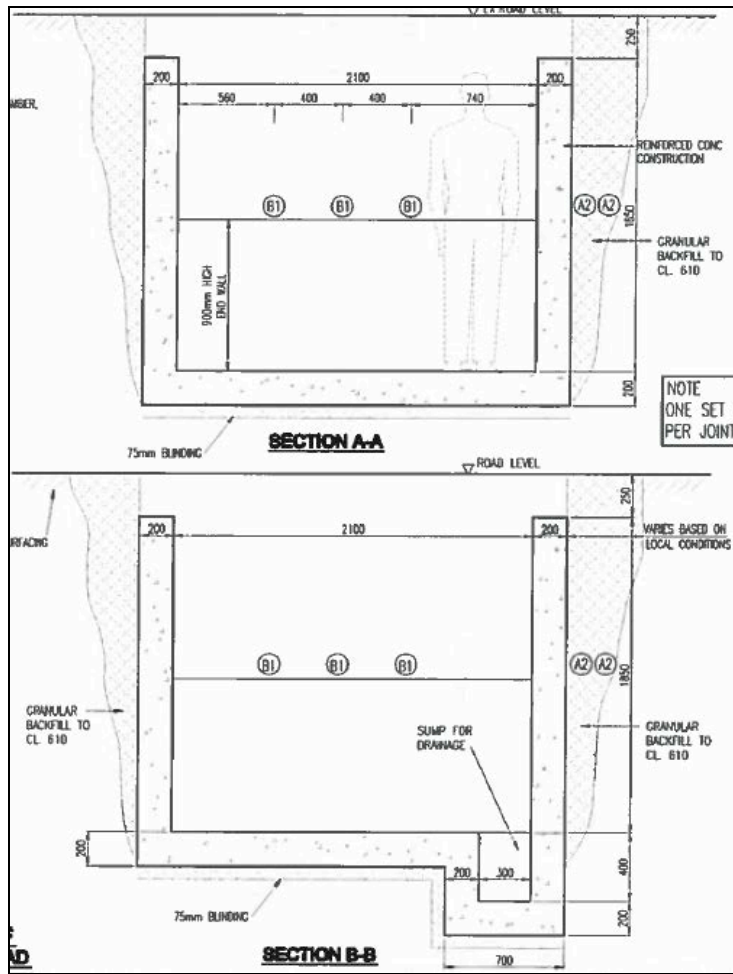

Cross section of joint bay

