

# Generation Facilities

## Connection Application Form to the Transmission System

---

September 2020



# Introduction

This application form outlines the information EirGrid requires to progress an application for connection to the Transmission System. EirGrid recommends that the applicant refers to the customers section of the website [www.eirgrid.com](http://www.eirgrid.com) for further information on the application process. The website has links to other relevant documents such as the Grid Code. It should be noted that it is the applicant's responsibility to comply with the technical, design and operational standards detailed in the Grid Code.

Please note for the purpose of this application form TSO should be interpreted as: the holder of the license to operate Ireland's Transmission System (EirGrid).

Please note that this application form deals with HV connections only ( $\geq 110$  kV) and that if an MV ( $\leq 110$  kV) supply is required the applicant should first contact ESB Networks: Tel: +353 850 372 757, [www.esb.ie](http://www.esb.ie)

EirGrid reserves the right to request additional data if necessary and the applicant should provide such information promptly during and post the offer process.

It is EirGrid's responsibility to determine the transmission connection method. If the applicant has a specific request this will be considered and examined in the process. The selected method will be based on the overall least cost technically acceptable solution unless the applicant requests otherwise or EirGrid requires an alternative method for system reasons.

Definitions of terms used in this form can be found in the Glossary of the Grid Code.

The following information will be disclosed in the applications list found in the 'Completed Generation Applications' section on [www.eirgrid.com](http://www.eirgrid.com) once the application is deemed fully complete by EirGrid:

- project name,
- applicant details (contact name, email address, telephone number),
- received complete date,
- status of application,
- grid co-ordinates of electrical connection point,
- capacity of project (MW),
- assigned transmission station, and
- generation type.

Please note that if the application is not initially deemed complete, then the received complete<sup>1</sup> date is recorded as the date that all necessary information has been provided to the system operator.

Please note that payment of application fees can only be made via electronic fund transfer into the following account. Cheques are not accepted.

---

<sup>1</sup> More information on the Received Complete Date is available at: <http://gridshare/sites/FG/CPC/CPC%20Policy%20Documentation%20Project/Basis%20for%20calculating%20%20Received%20Complete%20Date%20-%20FINAL.pdf>

Bank Details:  
Barclays Bank Ireland Plc  
2 Park Place,  
Hatch Street  
Dublin 2  
D02 NP94

Sort Code: 99-02-12  
Account Name: EirGrid No 2 Account  
Account Number: 42890602  
Swift Code: BARCIE2D  
  
IBAN: IE80BARC99021242890602

When the application form is completed please send the form to the below address, or email to [OPMO@eirgrid.com](mailto:OPMO@eirgrid.com)

EirGrid  
Customer Relations  
The Oval,  
160 Shelbourne Road,  
Ballsbridge,  
Dublin 4,  
D04 FW28  
Ireland.

Tel: +353 1 23 70472  
Fax: +353 1 661 5375

For the avoidance of doubt:

- Section 1 applies to all applicants
- Section 2 applies to all applicants
- Section 3 A applies to renewable and inverter based generation e.g. wind, solar, batteries etc.
- Section 3 B applies to conventional generation
- Section 4 applies to all applicants
- Section 5 applies to applicants seeking DS3 prioritisation under CRU/18/058
- Section 6 applies to all applicants.

Please Note: Information contained within this application form may need to be shared with the Distribution System Operator in order to sufficiently assess the application.

## 1. Details of Applicant

**This section applies to all applicants**

*Please confirm if this application is an update on a previous application for the Facility?*

Yes  No

*If Yes, please confirm the TG/DG reference supplied by the relevant System Operator:*

--	--	--	--	--	--	--	--	--	--

**1. Full name of the applicant.**

---

**2. Address of the applicant or in the case of a corporate body, the registered address and company registration number.**

---

---

Company Registration No. (If applicable)

**3. Telephone Number**

--	--	--	--	--	--	--	--	--	--

**4. Contact Person(s)**

---

**5. Email Address**

---

**6. Contact Address (if different)**

---

---

7. Please nominate a preferred name for the facility.

---

Please Note: The TSO will take this preferred name into consideration when determining the facilities' station name but reserves the right to change it in order to avoid any potential for confusion with other projects or stations. Please refer to Appendix A for EirGrid's policy on User Site/Station Naming.

8. Please specify the address of the facility.

---

---

9. Please confirm if you have achieved planning permission<sup>2</sup> for the facility.

Yes  No

Please refer to Section 6 of this application form for inputting planning permission details

10. It should be noted that it is the applicant's responsibility to comply with the technical design and operational standards detailed in the Grid Code.

Noted

11. Has the applicant signed a confidentiality agreement with the TSO for this facility?

Yes  No

If no, two copies have to be submitted with application form. Confidentiality agreement templates can be found on EirGrid's website, [www.eirgrid.com](http://www.eirgrid.com)

12. Has the applicant previously had a pre-feasibility study regarding this facility completed by TSO?

Yes  No

If yes, please specify name and the date of issue of the Pre-feasibility study(s).

---

<sup>2</sup> As per CRU20/060, planning permission is a pre-requisite for applications entering ECP-2.1

Study 1:

(D/M/Y)

---

Study 2:

(D/M/Y)

---

## Maps and Diagrams

**13.** Please provide a 1:50,000 “Discovery Series” Ordnance Survey map, with the location address of the facility clearly marked. The electrical connection point must be clearly marked with an “X”.

Name of OS map attachment:

---

Grid co-ordinates of the electrical connection point of your site (In appendix A an example is shown of how to correctly specify the grid co-ordinates):

Easting

--	--	--	--	--	--	--

Northing

--	--	--	--	--	--	--

**14.** Please provide a site plan in an appropriate scale. This site plan should be submitted in soft copy only and indicate:

- the site boundary,
- the proposed location of the connection point,
- generators,
- transformers,
- site buildings and
- meteorological masts etc.

Note that the connection point is normally at the HV bushings of the grid connected transformer. Space for the transmission compound will have to be clearly marked on the site plan. The exact size of the compound will depend on the connection method defined in the connection offer.

Name of site plan attachment.

---

Please note that EirGrid may require an option from the applicant for additional land at the facility to facilitate future development of the Transmission System.

Noted

**15.** Please provide an electrical Single Line Diagram (SLD) of the proposed facility in soft copy only detailing all significant items of plant and their values.

- relevant voltage levels,
- generator transformer(s),
- power factor correction devices,
- location of alternative connection for house load (if applicable) and

- grid connected transformer(s).

Name of the SLD attachment soft copy;

---

**16.** For applications where the below is applicable:

Please provide a functional block diagram of the main plant components, showing boilers, turbines, heat recovery boilers, alternators, any heat or steam supplies to other processes etc. The functional block diagram must indicate whether single or separate shaft is to be utilised in the case of CCGT.

Noted



## 2. General Data

**This section applies to all applicants**

**17. Maximum Export Capacity (MEC) required in MW.**

This is the amount of exporting transmission capacity that will be provided for in the connection offer and is the maximum capacity that can be exported onto the transmission system.

MEC  (MW)

**18. State the number of connecting circuits to the Transmission System (e.g. one, two etc.) the applicant requires for technical and/or security reasons.**

---

Please also state any specific connection method requests e.g. the use of underground cabling or connection to a specific station etc.

---

---

---

Please note that while underground cabling may be quicker to build than overhead line, however it is more expensive and in certain areas of the country the use of underground cabling can have impacts on the Transmission System. For example amplification of background harmonic distortion, that would require additional equipment to be installed to mitigate their impact.

Where the possibility of harmonic amplification exists more detailed studies are required during the process leading to the issuance of a Connection Offer which may not be possible to complete within the standard 90 business day timeframe. Please also note that customers pay for 100% of the least cost connection method. Customer requested connection methods above and beyond the least cost connection method are fully chargeable to customers.

Further information on this aspect of charging policy is available at:  
<http://www.eirgridgroup.com/customer-and-industry/general-customer-information/connections-and-contracts/>

**19. Confirm whether you wish the connection offer to issue on a contested or a non-contested basis and broadly outline the works the customer wishes to contest.**

Further information on contestability is available at:

<http://www.eirgridgroup.com/site-files/library/EirGrid/Contestability-and-Connection-Assets.pdf>

---

---

---

### 3. Section A: Inverter based Generation

This section applies to renewable and inverter based generation

#### Generating Unit details

Type 1      Type 2      Type 3

20. Manufacturer of generating unit			
21. Model and type generating unit			
22. Number of generators of type			
23. Rated power output of each generating unit (MW)			
24. Generating unit rated MVA			
25. Generating unit voltage (kV)			

26. Please provide a power curve approved by the generating unit manufacturer and specific to the generating unit(s) specified above.

Submitted

Name of attachment:

---

27. Please provide a power quality test report.

Submitted

Name of attachment:

---

#### Generating Unit Transformer Information

All impedances in % on transformer MVA base.

	Type 1	Type 2	Type3
28. Rating of WTG/inverter transformer (MVA)			
29. WTG/inverter transformer voltage ratio MV/LV (kV)			
30. WTG/inverter transformer positive sequence resistance (R <sub>1</sub> %)			

<b>31.</b> WTG/inverter transformer positive sequence reactance ( $X_1\%$ )			
<b>32.</b> WTG/inverter transformer zero sequence resistance ( $R_0\%$ )			
<b>33.</b> WTG/inverter transformer zero sequence reactance ( $X_0\%$ )			
<b>34.</b> WTG/inverter transformer vector group			

**35. Number of inductive devices.**

---

Indicate for each device the inductive MVar capability. If the device has more than one stage please indicate the number of stages and the MVar capability switched in each stage.

MVar       steps

MVar       steps

**36. Number of capacitive devices.**

---

Indicate for each device the capacitive MVar capability. If the device has more than one stage please indicate the number of stages and the MVar capability switched in each stage.

MVar       steps

MVar       steps

**37. Please indicate the MVar contribution of the internal generation facility structure (i.e. 20 kV cable)**

MVar

**38. Please provide test results demonstrating fault ride through capability in accordance with Figure WFPS1.1 in the Wind Grid Code ref: WFPS1.4.1.**

Name of the attachment:

---

### Internal Generation Facility Network Structure

**39.** Please describe how the generation facility's internal network structure (collector network) will be laid out. The description should include a breakdown of how the individual turbines/inverters are connected together as well as how they are connected back to the generation facility substation. Please specify different cable sizes and individual lengths of cable.

Name of internal network structure attachment:

---

	Type 1	Type 2	Type3
<b>40.</b> Conductor cross sectional area per core (mm <sup>2</sup> )			
<b>41.</b> Conductor type (Al, Cu, etc.)			
<b>42.</b> Type of insulation			
<b>43.</b> Total length of Cable Type (km)			

## Section B: Conventional Generation

This section applies to conventional generators

44. Please provide details of the expected running regime. (E.g. base load, peaking etc.)

---

### Plant Capability Data

Generator capabilities must comply with the Grid Code. Please review the connection conditions for a list of the required standards.

	Unit 1	Unit 2	Unit 3
45. Type of generation plant (hydro, combined cycle, combustion turbine, steam turbine, gas turbine etc.)			
46. Primary Fuel Source			
47. Secondary Fuel Source			
48. Manufacturer of generator			
49. Model and type of above generator			
50. Type of generator (synchronous, asynchronous, etc.)			
51. Number of generators of type			
52. Generator voltage (kV)			
53. Generator rated MVA			
54. Maximum continuous generation capacity at normal operating air conditions <sup>(1)</sup> (MW).			
55. Minimum continuous generating capacity (MW)			

<sup>(1)</sup> Normal operating air conditions to be assumed = 10°C, 1.01bar, 70% humidity.

Please note that the sum of the maximum continuous generation capacity at normal operating air conditions for the individual generators unit shall be used to record the Installed Plant (as defined in the Grid code) for the purposes of the connection offer.

### Grid Connected Transformer Data

There are many types of transformers. This application form specifies two and three winding transformers in Appendix B. Please fill in relevant section. All impedances should be stated in % on transformer MVA base.

Please note that the connection voltage is determined by EirGrid in accordance with normal standards as detailed in the Grid Code taking into account the particulars of each development. If the connection voltage differs to that specified in the Application, EirGrid will request new data corresponding to the new voltage level. An appropriate connection voltage will initially be examined as part of the application check.

## 4. Station Data

This section applies to all applicants

**56.** Please specify the Maximum Import Capacity (MIC) required in MVA. This is the amount of import capacity that the site will require during start up and will be provided for in the connection offer.

MIC  (MVA)

If the requested MIC is >1MVA please state the following:

Active Power P  MW

Reactive Power Q  MVA<sub>r</sub>

**57.** Please specify the House Load required for the site under normal operating conditions.

MW  MVA<sub>r</sub>

**58.** Please state if a separate transmission connection is required to supply House Load.

Yes  No

If required please submit details.

Name of attachment:

---

**59.** Please provide a reactive capability curve:

For Inverter based Generation

For the site as measured at the lower voltage side of the grid connection transformer. The capability curve should specify MVA<sub>r</sub> vs MW for the entire range of MW output. The curve should be consistent with the answers given in the questions above.

For Conventional Generation

For the entire active power operating range for each generator as provided at the alternator terminals and at normal operating conditions.

Name of the attachment:

---

**60.** Please state the power factor ranges of the generator type at the specified active power percentages of the maximum continuous export capacity and then specify the equivalent MVar capability.

		35%		100%	
		Ind.	Cap.	Ind.	Cap.
Type 1	Equivalent MVar				
Type 2	Equivalent MVar				
Type 3	Equivalent MVar				

**Generation Data for Fault Studies (Short Circuit)**

**For Renewable Generation (Qu 61 – 62)**

**61.** Please provide the following currents for each type of wind turbine generator/solar invert used in the generation facility.

	Type 1	Type 2	Type3
$I_K''$ – Initial symmetrical short circuit current			
$I_P$ – Peak short circuit current			
$I_{b100}$ – Short circuit breaking current at 100ms			
$I_{b80}$ – Short circuit breaking current at 80ms			
$I_K$ – Steady state short circuit current			

**62.** Please provide a short circuit decrement curve (current vs. time) that represents each type of wind turbine generator/solar inverter used in the generation facility.

Name of attachment(s):

---

**For Conventional Generation (Qu 63 – 69)**

<b>63.</b> $X_d'$ – Generator Direct Axis Transient Reactance (unsaturated): (pu on machine MVA base)			
<b>64.</b> $X_d$ – Generator Direct Axis Transient Reactance			



(saturated): (pu on machine MVA base)			
<b>65.</b> $X_d''$ – Generator Sub-transient Reactance (unsaturated): (pu on machine MVA base)			
<b>66.</b> $X_d''$ – Generator Sub-transient Reactance saturated): (pu on machine MVA base)			
<b>67.</b> $X_2$ – Generator Negative Phase Sequence Synchronous Reactance: (pu on machine MVA base)			
<b>68.</b> $X_0$ – Generator Zero Phase Sequence Reactance: (pu on machine MVA base)			

**69.** Please submit the open-circuit generator magnetic saturation curve. If this data is not available at this stage EirGrid will assume the magnetic saturation characteristics for the generator to be in accordance with Appendix C.

Complete tick the appropriate boxes for the following section:

Please assume generator magnetic saturation curve as per Appendix C,

**OR**

Please assume other generator magnetic saturation curve.

Name of attachment specifying curve:

---

## Dynamic Simulation Data

### This section applies to all applicants

For EirGrid to be able to carry out dynamic simulations the applicant needs to submit dynamic simulation information appropriate to their facility. Please select one of the following ways for providing the dynamic simulation data:

**A.**The applicant can submit a soft copy of a PSSE Dynamic Model representation of the generation facility connected to a simple grid system. Please see the EirGrid website for general details on how to prepare a sample PSSE model of a connection:

**OR**

**B.**The applicant can submit the specific dynamic simulation data requested in Appendix C, D, E and F or already included on the dynamic model register on the EirGrid website, whichever is applicable.

Please note that exact information and parameters regarding excitation, governor systems and power system stabiliser will be required at the time of commissioning and failure to produce this may result in a delay in energisation of the facility.

.

## 5. DS3 Applicants

70. Please indicate which services can be provided

FFR

POR

### Fast Frequency Response

71. What level of FFR can be provided?

FFR  (MW)

72. For how many hours per year can the service be provided?

---

73. Service at low MW outputs

Can the service be provided at 0MW output levels?

Yes

No

Can the service be provided while operating below 20% of MEC?

Yes

No

### Primary Operating Reserve

74. What level of POR can be provided?

POR  (MW)

75. For how many hours per year can the service be provided?

---

76. Service at low MW outputs

Can the service be provided at 0MW output levels?

Yes

No

Can the service be provided while operating below 20% of MEC?

Yes

No

## 6. Planning Permission Confirmation<sup>3,4</sup>

This section applies to all applicants<sup>4</sup>

Telephone \_\_\_\_\_ Email \_\_\_\_\_

I (Name in Block Capitals) \_\_\_\_\_,

Position: \_\_\_\_\_,

on behalf of (Company Name in Block Capitals as specified in the Applicant Detail of this application form)

\_\_\_\_\_

confirm that Planning Permission for the generator units as specified in this application form is in place as follow:

**Planning Reference No:** \_\_\_\_\_

**Planning Permission Grant Date** \_\_\_\_\_

**Planning Reference No:** \_\_\_\_\_

**Planning Permission Expiry Date:** \_\_\_\_\_

**Extension applied for?** YES  NO

**OR**

Confirm that Planning Permission for the generator units as specified in this application is not required for the following reason:

\_\_\_\_\_  
\_\_\_\_\_

Signed: \_\_\_\_\_ Date: \_\_\_\_\_

<sup>3</sup> As per CRU20/060 if an applicant makes a false, misleading or inaccurate declaration in respect of planning permission requirements, this will be deemed to be an "event of default" under the connection agreement.

<sup>4</sup>

As per CRU/20/060 Planning permission required to apply to ECP-2, except for community-led projects, though they will need planning permission to receive a connection offer. Planning permission is one of the prioritisation criteria in the event of over-subscription as per CRU/20/060.

And I, (Name in Block Capitals), \_\_\_\_\_,

Profession: \_\_\_\_\_,

on behalf of (Company Name in Block Capitals)

\_\_\_\_\_

warrant that I have conducted the necessary checks and am satisfied that the  
aforementioned planning permission is in place if applicable.

\_\_\_\_\_

Date: \_\_\_\_\_

Solicitor / Planning Consultant Address:

\_\_\_\_\_  
\_\_\_\_\_

Solicitor<sup>5</sup> / Planning Consultant Number<sup>6</sup>:

\_\_\_\_\_

Solicitor / Planning Consultant Stamp:

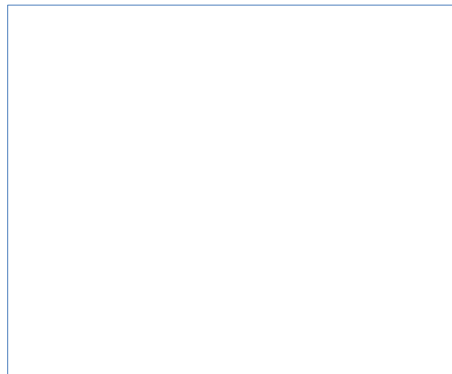

<sup>5</sup> As per the Law Society of Ireland ([www.lawsociety.ie](http://www.lawsociety.ie))

<sup>6</sup> As per the Irish Planning Institute ([www.ipi.ie](http://www.ipi.ie)) or Royal Town Planning Institute ([www.rtpiconsultants.co.uk](http://www.rtpiconsultants.co.uk))

## Appendixes

### Appendix A

#### EirGrid's policy on Station Naming:

- Station name must be unique and pronounceable for all stations,
- Station name must be geographically accurate and descriptive,
- Station name should be as local as possible to provide for future proofing for other stations that may locate in the same area,
- Station names should be identified in the following order;
  - town land it is situated in,
  - nearby town land,
  - adjacent landmark, i.e. a mountain.
- Station names should not be named after a company, any individual supplier or manufacturer as this is liable to change,
- Station name must not start with the letter X as this is reserved for ETSO.

Note: Station name above applies to both the transmission station name and the user's site name.

EirGrid will also assign a unique 3 character code to each generation unit which are used by various software for modelling purposes and dispatch purposes. This 3 character code is based on the user site name and the number of generators at that site.

## Appendix B

All impedances should be stated in % on transformer rated MVA base.

Please note that the connection voltage is determined by EirGrid in accordance with normal standards, as detailed in the Grid Code, taking into account the particulars of each development. If the connection voltage differs from that specified in this application, EirGrid will request new data corresponding to the new voltage level. An appropriate connection voltage will initially be examined as part of the application check.

### Two Winding Transformers

	Transformer 1	Transformer2
<b>B1.</b> Rating of Transformer (MVA)		
<b>B2.</b> Transformer voltage ratio HV/ LV (kV)		
<b>B3.</b> Transformer positive sequence resistance ( $R_1\%$ )		
<b>B4.</b> Transformer positive sequence reactance ( $X_1\%$ )		
<b>B5.</b> Transformer zero sequence resistance ( $R_0\%$ )		
<b>B6.</b> Transformer zero sequence reactance ( $X_0\%$ )		
<b>B7.</b> Transformer vector group		

**B8.** Please provide details of tap changer.  
Nature of tap changer off load/on load/off circuit)

---

Transformer 1: Tapped voltage winding

	kV	+	Steps	-	Steps		% Step Size
--	----	---	-------	---	-------	--	-------------

Transformer 2: Tapped voltage winding

	kV	+	Steps	-	Steps		% Step Size
--	----	---	-------	---	-------	--	-------------

**Three Winding Transformers**

Transformer 1

	HV winding	LV1 winding	LV2 winding
<b>B9.</b> Transformer rated MVA			
<b>B10.</b> Transformer rated voltage (kV)			
<b>B11.</b> Transformer vector group			

Transformer 2

	HV winding	LV1 winding	LV2 winding
<b>B12.</b> Transformer rated MVA			
<b>B13.</b> Transformer rated voltage (kV)			
<b>B14.</b> Transformer vector group			

Clearly specify the MVA base (in space provided between brackets) which the measured impedances below are related to:

Transformer 1      Transformer 2

<b>B15.</b> Transformer positive sequence resistance ( $R_{1HL1}\%$ ) between HV/LV1:	( )	( )
<b>B16.</b> Transformer positive sequence reactance ( $X_{1HL1}\%$ ) between HV/LV1:	( )	( )
<b>B17.</b> Transformer zero sequence resistance ( $R_{0HL1}\%$ ) between HV/LV1:	( )	( )
<b>B18.</b> Transformer zero sequence reactance ( $X_{0HL1}\%$ ) between HV/LV1:	( )	( )
<b>B19.</b> Transformer positive sequence resistance ( $R_{1HL2}\%$ ) between HV/LV2:	( )	( )
<b>B20.</b> Transformer positive sequence reactance ( $X_{1HL2}\%$ ) between HV/LV2:	( )	( )
<b>B21.</b> Transformer zero sequence resistance ( $R_{0HL2}\%$ ) between	( )	( )



HV/LV2:		
<b>B22.</b> Transformer zero sequence reactance ( $X_{0HL2}\%$ ) between HV/LV2:	( )	( )
<b>B23.</b> Transformer positive sequence resistance ( $R_{1L1L2}\%$ ) between LV1/LV2:	( )	( )
<b>B24.</b> Transformer positive sequence reactance ( $X_{1L1L2}\%$ ) between LV1/LV2:	( )	( )
<b>B25.</b> Transformer zero sequence resistance ( $R_{0L1L2}\%$ ) between LV1/LV2:	( )	( )
<b>B26.</b> Transformer zero sequence reactance ( $X_{0L1L2}\%$ ) between LV1/LV2:	( )	( )
<b>B27.</b> Transformer positive sequence resistance ( $R_{1HL1L2}\%$ ) between HV/(LV1+LV2):	( )	( )
<b>B28.</b> Transformer positive sequence reactance ( $X_{1HL1L2}\%$ ) between HV/(LV1+LV2):	( )	( )
<b>B29.</b> Transformer zero sequence resistance ( $R_{0HL1L2}\%$ ) between HV/(LV1+LV2):	( )	( )
<b>B30.</b> Transformer zero sequence reactance ( $X_{0HL1L2}\%$ ) between HV/(LV1+LV2):	( )	( )

**B31.** Please provide details of tap changer.  
Nature of tap changer (off load/on load/off circuit):

---

Transformer 1 : Tapped voltage winding

	kV	+	Steps	-	Steps	%	Step Size
--	----	---	-------	---	-------	---	-----------

Transformer 2 : Tapped voltage winding

	kV	+	Steps	-	Steps	%	Step Size
--	----	---	-------	---	-------	---	-----------

**Appendix C**  
**Conventional Generation Units**  
**Generator Data**

	Unit 1	Unit 2	Unit 3
<b>C1.</b> $X_d$ – Generator Direct Axis Positive Phase Sequence Synchronous Reactance: (pu machine MVA base)			
<b>C2.</b> $X_q$ – Generator Quadrature Axis Positive Phase Sequence Synchronous Reactance: (pu machine MVA base)			
<b>C3.</b> $X_q'$ – Generator Quadrature Axis Transient Reactance (unsaturated): (pu machine MVA base) (Note: Not applicable to induction generators).			
<b>C4.</b> $X_l$ – Armature Leakage Reactance: (pu machine MVA base)			
<b>C5.</b> $T_{do}'$ – Generator Direct Axis Transient Open Circuit Time Constant: (Sec)			
<b>C6.</b> $T_{do}''$ – Generator Direct Axis Subtransient Open			
<b>C7.</b> $T_{qo}'$ – Generator Quadrature Axis Transient Open Circuit Time Constant: (Sec)			
<b>C8.</b> $T_{qo}''$ – Generator Quadrature Axis Subtransient Open Circuit Time Constant: (Sec)			
<b>C9.</b> H – Inertia of complete turbogenerator including primemover gearbox if fitted (MWs/MVA)			

**Appendix D  
Conventional Generation Units  
Magnetisation Saturation Curves**

**D1.** Please submit the open-circuit generator magnetic saturation curve. If this data is not available at this stage EirGrid will assume the magnetic saturation characteristics for the generator to be in accordance with figure below.

Complete tick the appropriate boxes for the following section:

Please assume generator magnetic saturation curve as per Figure 1.

**OR**

Please assume other generator magnetic saturation curve.

Name of attachment specifying curve:

p.u. Saturation Function  $S(x)$

$S(1.0)=0.10$

$S(1.2)=0.33$

The saturation function is defined in terms of the open terminal voltage versus field current characteristics shown below in Figure 1. From this figure we define:  $S(1.2)=(A_{1.2}-B_{1.2})/B_{1.2}$

$S(1.0)=(A_{1.0}-B_{1.0})/B_{1.0}$

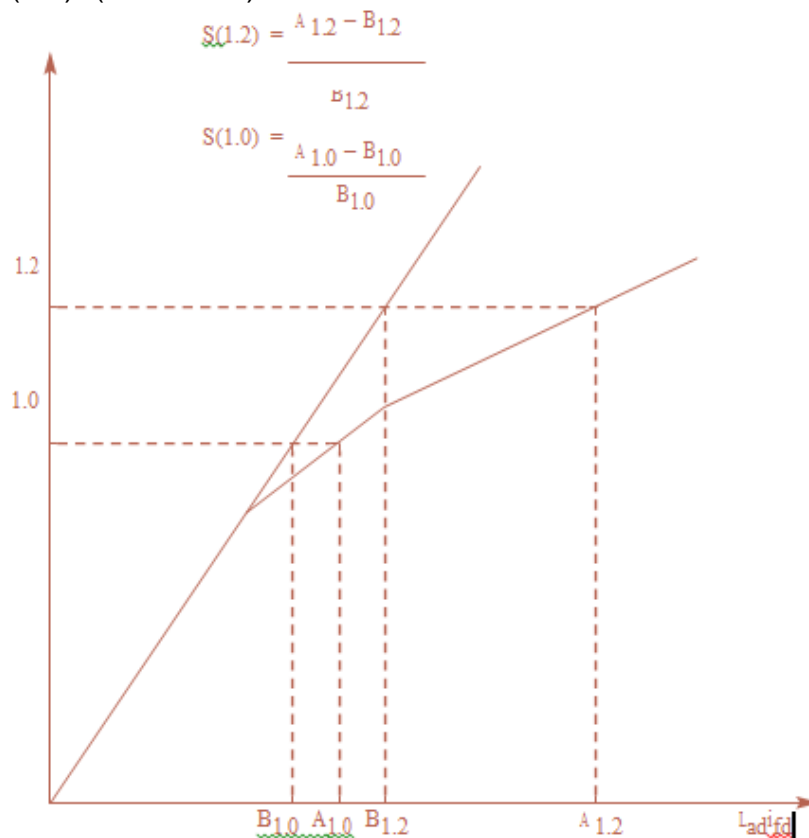

**Figure 1: Magnetisation Saturation Curve**

## **Appendix E**

### **Conventional Generation Units**

#### **Excitation System**

**E1.** Please submit a Laplace-domain control block diagram that represents the generator excitation system in accordance with IEEE standard excitation models or as otherwise agreed with EirGrid. This control block diagram should specify all time constants and gains to fully explain the transfer function from the compensator or generator terminal voltage and field current to generator field voltage.

A list of acceptable IEEE standard excitation models available within the PSS/E simulation package used by EirGrid is shown below.

#### **Excitation System Models**

Below is a list of the standard excitation system models contained in the PSS/E dynamics model library.

**ESAC1A** 1992 IEEE type AC1A excitation system model  
**ESAC2A** 1992 IEEE type AC2A excitation system model  
**ESAC3A** 1992 IEEE type AC3A excitation system model  
**ESAC4A** 1992 IEEE type AC4A excitation system model  
**ESAC5A** 1992 IEEE type AC5A excitation system model  
**ESAC6A** 1992 IEEE type AC6A excitation system model  
**ESAC6A** 1992 IEEE type AC6A excitation system model  
**ESAC8B** Basler DECS model  
**ESDC1A** 1992 IEEE type DC1A excitation system model  
**ESDC2A** 1992 IEEE type DC2A excitation system model  
**ESST1A** 1992 IEEE type ST1A excitation system model  
**ESST2A** 1992 IEEE type ST2A excitation system model  
**ESST3A** 1992 IEEE type ST3A excitation system model  
**ESST4B** IEEE type ST4B potential or compounded source-controlled rectifier exciter  
**EX2000** EX2000 Excitation system  
**EXAC1** 1981 IEEE type AC1 excitation system model  
**EXAC1A** Modified type AC1 excitation system model  
**EXAC2** 1981 IEEE type AC2 excitation system model  
**EXAC3** 1981 IEEE type AC3 excitation system model  
**EXAC4** 1981 IEEE type AC4 excitation system model  
**EXBAS** Basler static voltage regulator feeding dc or ac rotating exciter model  
**EXDC2** 1981 IEEE type DC2 excitation system model  
**EXELI** Static PI transformer fed excitation system model  
**EXPIC1** Proportional/integral excitation system model  
**EXST1** 1981 IEEE type ST1 excitation system model  
**EXST2** 1981 IEEE type ST2 excitation system model  
**EXST2A** Modified 1981 IEEE type ST2 excitation system model  
**EXST3** 1981 IEEE type ST3 excitation system model  
**IEEET1** 1968 IEEE type 1 excitation system model  
**IEEET2** 1968 IEEE type 2 excitation system model  
**IEEET3** 1968 IEEE type 3 excitation system model

- IEEET4** 1968 IEEE type 4 excitation system model
- IEEET5** Modified 1968 IEEE type 4 excitation system model
- IEEEX1** 1979 IEEE type 1 excitation system model and 1981 IEEE type DC1 model
- IEEEX2** 1979 IEEE type 2 excitation system model
- IEEEX3** 1979 IEEE type 3 excitation system model
- IEEEX4** 1979 IEEE type 4 excitation system, 1981 IEEE type DC3 and 1992 IEEE type DC3A models
- IEET1A** Modified 1968 IEEE type 1 excitation system model
- IEET1B** Modified 1968 IEEE type 1 excitation system model
- IEET5A** Modified 1968 IEEE type 4 excitation system model
- IEEX2A** 1979 IEEE type 2A excitation system model
- SCRX** Bus or solid fed SCR bridge excitation system model
- SEXS** Simplified excitation system model
- URST5B** IEEE proposed type ST5B excitation system (obsolete)
- URST5T** IEEE proposed type ST5B excitation system

**Shunted Fed Excitation Model with Typical Parameters**

Figure 2 represents the excitation logic model assumed. Parameters are set so to bypass the negative current logic. SCR X

Value	Description
0.1	TA/TB
10	TB (seconds)
200	K
0.05	TE (seconds)
0	EMIN
4	EMAX
0	CSWITCH

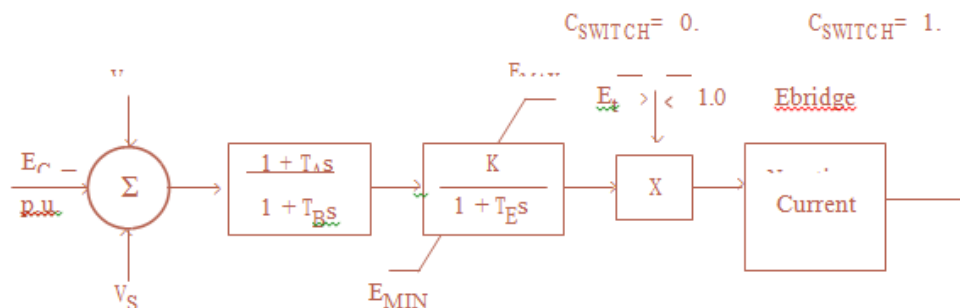

**Figure 2: Shunted Fed Excitation Model with Typical Parameters**

**Appendix F  
Conventional Generation Units  
Power System Stabiliser (PSS)**

**F1.** Please provide the details of the proposed Power system stabiliser (PSS) to be installed.

Noted

Name of attachment:

---

**Appendix G  
Conventional Generation Units  
Turbine – Governor System Models**

**G1.** Please submit a Laplace-domain control block diagram that represents the generator’s turbine-governor system in accordance with IEEE standard turbine-governor models or as otherwise agreed with EirGrid. This control block diagram should specify all time constants and gains to fully explain the transfer function from the compensator or generator terminal voltage and field current to generator field voltage.

A list of acceptable IEEE standard turbine-governor models available within the PSS/E simulation package used by EirGrid is shown below.

Complete the following section as appropriate:

**A.** Please assume model from list below.

---

Name of attachment detailing the data parameters for the specified turbine-governor model:

---

**OR**

**B.** Please assume other model:

---

Name of attachment specifying model and all necessary data parameters:

---

**OR**

**C.** If turbine-governor system data is not available at this stage EirGrid will assume a standard model with corresponding parameters for the turbine-governor system. The assumed turbine-governor model for dynamic simulation is detailed in Figure 3 below.

Please assume the model detailed in Figure 3 as our turbine-governor system.

Below is a list of the standard turbine-governor system models contained in the PSS/E dynamics model library.

- CRCMGV** Cross compound turbine-governor model
- DEGOV** Woodward diesel governor model
- DEGOV1** Woodward diesel governor model
- GAST** Gas turbine-governor model
- GAST2A** Gas turbine-governor model
- GASTWD** Gas turbine-governor model
- HYGOV** Hydro turbine-governor model
- IEEEG1** 1981 IEEE type 1 turbine-governor model
- IEEEG2** 1981 IEEE type 2 turbine-governor model
- IEEEG3** 1981 IEEE type 3 turbine-governor model
- IEESGO** 1973 IEEE standard turbine-governor model
- PIDGOV** Hydro turbine and governor model
- TGOV1** Steam turbine-governor model
- TGOV2** Steam turbine-governor model with fast valving
- TGOV3** Modified IEEE type 1 turbine-governor model with fast valving
- TGOV5** Modified IEEE type 1 turbine-governor model with boiler controls
- WEHGOV** Woodward electronic hydro governor model
- WESGOV** Westinghouse digital governor for gas turbine
- WPIDHY** Woodward P.I.D. hydro governor model

Governor System Model Typical Parameters

Value	Description
0.04	R
0.5	T1(>0) seconds
0.85	Vmax
0.2	Vmin
2	T1(>0) seconds
7	T1(>0) seconds
0	Dt

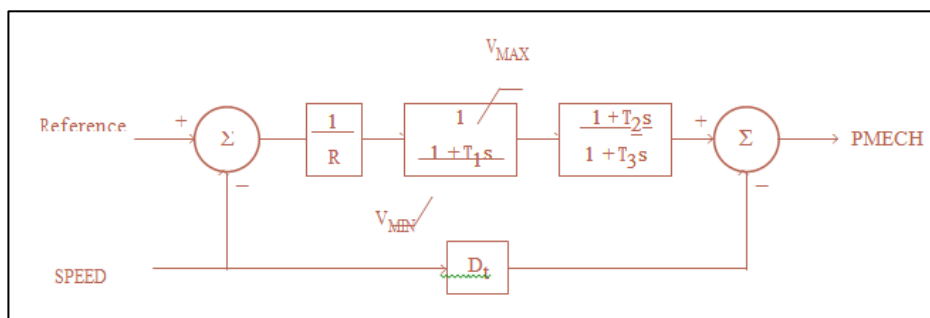

Figure 3: Turbine – Governor System Model

## **Appendix H Checklist:**

- Application form completed in full,
- Application fee,
- Two signed copies of confidentiality agreement (if applicable),
- OS map,
- Single line diagram (SLD), soft copy,
- Site plan including site boundary (soft copy),
- Power curve –soft copy,
- Power quality test report (if applicable),
- Reactive power capability curve,
- Fault ride through capability test results (if applicable),
- Internal network structure details (if applicable),
- Station data (if applicable),
- Short circuit decrement curve (if applicable),
- Suitable dynamics model and
- Functional block diagram of plant (if applicable).