

EMT Model Specification HVDC

Version 1.0

July 2025



The Oval, 160 Shelbourne Road, Ballsbridge, Dublin D04 FW28
Telephone: +353 1 677 1700 | www.eirgrid.com

Contents

1. Introduction	5
1.1. Scope & Purpose	5
1.2. Abbreviations.....	6
2. Intended use	7
2.1. Context.....	7
2.2. Studies	7
2.3. Model	7
3. Components	8
3.1. Plant Specific.....	8
3.2. Electrical Components of the Plant	8
3.3. Control and Protection of the Plant	8
3.4. Co-located (hybrid) Sites	10
4. Structure	10
4.1. Model Structure Requirements.....	10
4.2. Requirements for Layer 1.....	10
4.3. Requirements for Layer 2.....	10
4.4. Additional requirements for all Layers	11
4.5. Co-located (hybrid) Sites	11
5. Accuracy	11
5.1. System Accuracy	11
5.2. Electrical Components Accuracy	12
5.3. Control & Protection Accuracy	13
5.4. Aggregation.....	13
6. Usability	13
6.1. Simulation Software Requirements	13
6.2. PSCAD Requirements	14
6.3. EMTP Requirements	14
6.4. Packaging & Compatibility	14
6.5. Model Inputs, Configuration & Tuning	15
6.6. Simulation Performance & Stability.....	16
6.7. Diagnostics & Outputs.....	16

7. Documentation	18
7.1. Introduction	18
7.2. Model Overview and File Integrity	18
7.3. Model Configuration and Technical Content	19
7.4. Model Design Documentation	19
7.5. Model Test Case Requirements	20
8. Delivery & Maintenance	20
8.1. General.....	20
8.2. Model Delivery Timeline & Scope of Delivery.....	21
8.3. Model Maintenance	21
8.4. Model Checklist	21
9. References	22
10. Appendix	23
10.1. Appendix A: Model Checklist	23

Revision	Date	Description	Comments
V1.0	14/07/25	First release	

COPYRIGHT © EirGrid

All rights reserved. No part of this work may be modified or reproduced or copied in any form or by means - graphic, electronic or mechanical, including photocopying, recording, taping or information and retrieval system, or used for any purpose other than its designated purpose, without the written permission of EirGrid

1. Introduction

1.1. Scope & Purpose

This document has been published by the TSO to provide clarity on the electromagnetic transient (EMT) modelling requirements for **High Voltage Direct Current (HVDC) systems** in Ireland, as specified in Grid Code clause PC.A8 (Modelling Requirements for Users) [1.], in compliance with European legislation EU 2016/1447 reflected in the Network Code for High Voltage Direct Current Connections (HVDC) [2.]). The contents of this document are also in alignment with the recommended amendments to the existing HVDC Network Code submitted by ACER to the European Commission in December 2024 (HVDC 2.0) [5.], and expected to be approved in 2026.

As the Ireland and Northern Ireland power system moves towards a net zero carbon operation; the number of Inverter-Based Resources (IBR) and HVDC is expected to increase, with the amount of synchronous generation in the grid to decline, which will significantly change the dynamic characteristics of the All Island power system. These changes give rise to the potential of harmful control interactions between the devices and between the devices and the network, leading to risks of oscillations and inverter stability. These phenomena cannot be accurately and reliably studied using traditional RMS/Phasor domain models and require detailed EMT simulation. In order to plan and operate the All Island power system in a secure and reliable manner, the TSO requires all Users connected to, or applying for a connection to, the Transmission System to provide EMT models of their Plant following the specifications described in this document (GC PC.A8.1)¹. The document is intended to be read in conjunction with the Grid Code. Terms used in the document are in line with those specified in the Grid Code.

The objective of this document is to provide clear and consistent guidance with regards to the level of detail, model type, model accuracy, performance, usability and interoperability requirements for EMT models of HVDC systems in Ireland. Provision of EMT models compatible with these specifications will enable the TSO to effectively setup and integrate the individual HVDC systems model into a larger EMT network model and conduct wide-area simulation studies related to power system security and stability as well as to investigate recent sub-synchronous oscillations (SSO) incidents experienced in the All Island power system. The specifications described in this document are aligned with EMT model specifications already in place in other jurisdictions (see section 9. References), reflecting industry best practice. The HVDC systems owner is responsible for ensuring that the EMT model submitted to the TSO is developed and configured to meet the specifications described in this document and is accompanied by documentation demonstrating that it represents the overall HVDC systems, seen at the Point of Connection (PoC), as accurately as possible (GC PC.A8). This document applies to one specific type of equipment – the principal type within the plant. If the plant includes additional equipment or extensions of a different type (e.g. hybrid plant), these shall comply with the relevant specification outlined in a separate document.

This document describes:

- Intended use of the models.
- Components that must be included in the model.
- Structure of the model.
- Accuracy requirements for the model.
- Usability of the model.
- Requirements for model documentation.
- Requirements for delivery and maintenance/support of the model over the lifetime of the plant.
- Model checklist.

Requirements for model validation are described in a separate document.

¹ It should be noted that the model specifications described in this document are not subject to regulatory approval.

1.2. Abbreviations

AC	Alternative Current
BESS	Battery Energy Storage System
CB	Circuit Breaker
DC	Direct Current
DLL	Dynamic Link Library
EMT	Electromagnetic Transients
FFR	Fast Frequency Response
FRT	Fault Ride Through
HMI	Human Machine Interface
HVDC	High Voltage Direct Current
IBR	Inverter Based Resource
IGBT	Insulated-Gate Bipolar Transistor
MMC	Modular Multilevel Converter
MSS	Minimum System Strength
PED	Pre-Energisation Data
PLL	Phase-Locked Loop
PoC	Point of Connection
PPM	Power Park Module
RAS	Remedial Action Scheme
RMS	Root Mean Square
RoCoF	Rate of Change of Frequency
SCR	Short Circuit Ratio
SLD	Single Line Diagram
SMIB	Single Machine Infinite Bus
SSCI	Sub-Synchronous Control Interaction
SSO	Sub-Synchronous Oscillation
SSR	Sub-Synchronous Resonance
SSTI	Sub-Synchronous Torsional Interaction
TOV	Temporary Over-Voltage
TSO	Transmission System Operator
VSC	Voltage Source Converter
X/R	Reactance over Resistance ratio

2. Intended use

2.1. Context

HVDC_INT_1

As the Ireland and Northern Ireland power system moves towards a net zero carbon operation; the number of Inverter-Based Resources (IBR) and HVCD systems is expected to increase, with the amount of synchronous generation in the grid to decline, which will significantly change the dynamic characteristics of the All Island power system. These changes give rise to the potential of harmful phenomena between the devices and between the devices and the network, leading to potential instability issues. These phenomena can only be studied with detailed electromagnetic transients (EMT) models.

2.2. Studies

HVDC_INT_2

The EMT models provided as part of this specification will be integrated into a broader EMT network model, the scale of which will depend on the phenomena studied, ranging from studies of local phenomena to large-scale network simulation studies.

HVDC_INT_3

The EMT model will be used for integration studies, post event analysis, and interaction studies **during the entire life of the HVDC plant.**

HVDC_INT_4

The model will be used to carry out dynamic performance analysis and interactions studies including, but not limited to, the following list:

- Power system stability studies (for example voltage, frequency, rotor angle).
- Dynamic controls interactions studies (power oscillation, control loop interaction).
- Sub-synchronous phenomena analysis (including SSTI, SSR, SSCI).
- Harmonic stability analysis (harmonic instability, ferroresonance).
- Small disturbances (setpoint step changes).
- Transformer energisation studies.
- AC fault performance studies (for example, fault recovery, transient short circuit current analysis,)
- Protections performance studies
- Power quality studies² (for example harmonic voltage amplification, phase imbalance, flicker, harmonic amplification).
- Black-start or islanding operation studies (if applicable).

2.3. Model

HVDC_INT_5

² It should be noted that the EMT model is not intended to be used to assess harmonic emissions and compliance with harmonic voltage distortion limits allocated by the TSO. A different model (frequency domain) is required for those purposes.

The model must be capable of simulating the **dynamic behaviour of the connected plant**, as seen at the Point of Connection (PoC), under normal operating conditions, small disturbances (e.g. voltage step change) and large disturbances (e.g. balanced/unbalanced system faults, voltage disturbances and frequency disturbances) in the AC and DC systems.

HVDC_INT_6

The model must be capable to be used for the numerical calculation of the frequency dependent impedance of the plant at the connection point (impedance amplitude and impedance phase angle) in the frequency range that the model is valid as defined in section 5.1.

3. Components

3.1. Plant Specific

HVDC_COM_1

The EMT model must be specific to the equipment and the site; **generic models or parameters are not acceptable**.

HVDC_COM_2

The model characteristics provided (electrical model, parameters, topology of the plant, etc ...) must reflect the actual characteristics of the plant and not the manufacturer's default characteristics.

3.2. Electrical Components of the Plant

HVDC_COM_3

The model must include all the **high-voltage electrical components** (as specified by IEC 60038) and equipment of the plant up to the PoC, in the "HVDC Link" area described by Figure 1. A non-exhaustive list is given hereafter:

- HVDC converters.
- Power transformer(s), with tap changer (if applicable).
- Underground cables and overhead lines included in the installation (AC and DC).
- All circuit breakers including grading capacitor and insertion resistor when applicable.
- AC and DC harmonic filters, if applicable.
- Measuring equipment.
- Additional active power or reactive power control devices (e.g. AC and DC chopper, BESS, STATCOM, capacitor banks, shunt reactor), if applicable.
- Surge arresters.
- Neutral grounding devices (if applicable).

3.3. Control and Protection of the Plant

HVDC_COM_4

The model must include all the relevant **control processes** of the HVDC system. For HVDC converters controller, a minimum list of functions to be included is listed below (when applicable):

- Control involved in Fault Ride Through (FRT) functionality.
- Active power control.
- Frequency control.
- Synthetic inertia control (if applicable).
- Reactive power control.
- Voltage control (AC and DC).
- Transformer tap changer control.
- Control of additional active power and/or reactive power control devices (e.g. AC chopper, BESS, STATCOM, capacitor banks, shunt reactor).
- Special control features, when applicable (e.g., grid forming control and/or weak grid control, power oscillation damping (sub and super synchronous)).

HVDC_COM_5

The model must include all the relevant **protection processes** of the HVDC system. A minimum list of functions includes, when applicable:

- Protection involved in FRT functionality.
- Over/Under Voltage protection.
- Harmonic protection.
- Islanding protection.
- Overcurrent protection.
- Over/Under Frequency protection.
- Rate of Change of Frequency (RoCoF) protection.
- Negative phase sequence (voltage unbalance) protection.
- Any Remedial Action Schemes (RAS) that have been deemed to have material impact on the system.
- SSTI protection, when applicable.
- Any protection which can influence dynamic behaviour or FRT performance in the simulation period should be included. All protection systems included in the models must be consistent with the plant's performance standard.

Any protection (or control) functions capable of blocking or interrupting the output of the converters must be accurately represented in the model.

HVDC_COM_6

All Phase-Locked Loop (PLL) controllers included in the plant must be modelled as implemented in the actual equipment.

HVDC_COM_7

The EMT model must include all specific measurement methods, hardware filters, communications time delays between the different devices, if applicable, and any others specific implementation details which may impact the dynamic behaviour of the plant.

HVDC_COM_8

All setpoints (active and reactive power, voltage, frequency, etc ...) available to the TSO from the real plant must be represented in the model. Additional relevant setpoints and parameters that may impact the dynamic behaviour of the plant shall also be included. All operating control modes and activation of specific control and protection functions shall be available in the model as for the real plant on site.

3.4. Co-located (hybrid) Sites

HVDC_COM_9

In the particular case of co-located (hybrid) sites, i.e. when a connection project involves different technologies behind the same PoC, each technology type must be modelled using the relevant EMT model specifications published by the TSO that correspond to it. Both technology types still must be included in the same EMT model (see sections 4. Structure and 8. Delivery & Maintenance).

4. Structure

4.1. Model Structure Requirements

HVDC_STR_1

This section describes the harmonised model structure requirements. The EMT plant model must be organised in two layers, as described next.

4.2. Requirements for Layer 1

HVDC_STR_2

Purpose: Layer 1 defines the external electrical interface between the connected HVDC plant model and the simulated transmission system. It contains the PoC and the logic for current and voltage exchange with the grid equivalent.

Description: A high-level system representation with two elements visible - connected HVDC plant and grid equivalent - with a PoC busbar between the two - as illustrated in Figure 1.

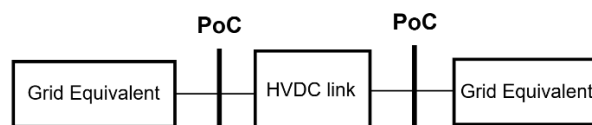

Figure 1: Layer 1 of the EMT model structure

4.3. Requirements for Layer 2

HVDC_STR_3

Purpose: Layer 2 acts as a bridge between the TSO interface and the internal connected unit(s). It manages plant-level control actions, interprets TSO commands, and aggregates unit-level feedback.

Description: A representation of key elements of the installation - plant controller & protection, connected unit(s), collector grid and any additional equipment (if applicable) - as represented in Figure 2.

- This is the layer where all setpoints, control modes, and loop (de)activations are managed.
- Communication with the TSO (in simulation or real operation) is modelled at this layer - as specified in section 6.5.
- A user-accessible HMI interface (virtual panel) must be included for testing the visibility of:
 - Setpoints (P, Q, V, PF, f)

- Plant status and mode selection
- Controller toggles (flags) (e.g., ride-through enable, fault mode)

The following must be provided in this layer:

- Plots and monitoring signals representative of global plant behaviour.
- A single point of access to adjust all variable control parameters (ramp rates, droop, delays, etc.).

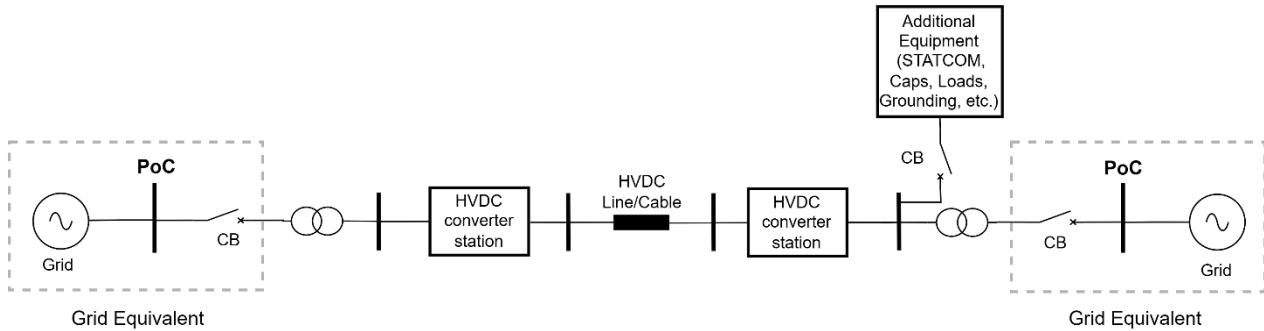

Figure 2: Layer 2 of the EMT model structure

4.4. Additional requirements for all Layers

HVDC_STR_4

All setpoints and variable parameters must be grouped for access and editing within Layer 2.

HVDC_STR_5

Diagnostic signals, trip indicators, and measurement outputs must be shown in Layer 2.

4.5. Co-located (hybrid) Sites

HVDC_STR_6

In the particular case of co-located (hybrid) sites, all technology types must still be included in the same EMT model and positioned inside the "Connected Plant" represented in Layer 2.

5. Accuracy

5.1. System Accuracy

HVDC_ACU_1

The model must be adequate for analysis of oscillatory behaviour of controls in sub-synchronous and super-synchronous ranges **from 0.2 Hz to 2.5 kHz**.

HVDC_ACU_2

The model needs to be numerically stable for operating conditions described in the Grid Code and for any studies listed in section 2. Intended use (including the full range of SCR and X/R values at the connection point provided by the TSO as pre-energisation data (PED)).

HVDC_ACU_3

All systems/components with time constant less than 100 seconds should be included in the model. For instance, and not limited to, control and protection logics, on-load tap changer controllers, and any other thermal, voltage or frequency related controller.

HVDC_ACU_4

The model must be numerically stable and accurate for a minimum **100 seconds** following any set point changes or system incidents/faults.

5.2. Electrical Components Accuracy

HVDC_ACU_5

Converter: The converter station should be modelled in detail including a detailed representation of the valves:

- for LCC technology each valve can be represented by a single thyristor.
- for VSC MMC technology: detailed MMC valve (Type4) shall be used as described in CIGRE TB604 [13.]. An aggregated valve model (Type5) can be accepted if a detailed validation report is provided to benchmark against detailed valve model.

HVDC_ACU_6

Transformer model requirements:

- Magnetizing saturation of the transformers must be included.
- Frequency dependency of transformer damping shall be included, the calculation methodology should be documented and parameters used should be accessible. The methodology described in the CIGRE reference [15.] can be used.

HVDC_ACU_7

Cables and overhead lines must use frequency-dependent models, although fixed frequency distributed line/cable model or lumped-circuit models could be accepted if they accurately represent the plant's response for the frequency range of validity of the model which is predefined above in section 5.1 and compliant with the simulation time step range predefined in section 6.6.

HVDC_ACU_8

Switching devices/Circuit Breakers: a simplified representation of a Point-on-Wave control device (where applicable) is accepted.

HVDC_ACU_9

Harmonic filters could be represented with lumped R/L/C components.

HVDC_ACU_10

Measuring Equipment: The appropriate representation of measuring equipment should be compatible with the prescribed validity frequency range (section 5.1) and type of studies (section 2.2) listed in this document.

HVDC_ACU_11

Additional **active power or reactive power control devices** (e.g. AC and DC chopper, BESS, STATCOM, capacitor banks, shunt reactor), if applicable: they need to respect the same level of requirements as the main equipment.

HVDC_ACU_12

Surge arresters: they must be represented if they have an impact on the dynamic performance of the system especially during the Temporary Over-Voltages (TOVs).

HVDC_ACU_13

Neutral grounding devices: they should always be included, with saturation characteristics included if relevant.

HVDC_ACU_14

General requirement: **Stray capacitances** shall be included if needed, to comply with the prescribed validity frequency range and type of studies listed.

5.3. Control & Protection Accuracy

HVDC_ACU_15

The "real code" (standard IEEE/CIGRE DLL vendor agnostic format and interface modelling method, as defined by Cigre TB 958 [14.]) must be included in the model for all control and protection functions, including signal processing.

HVDC_ACU_16

Communication and processing time delays:

- All intentional or inherent latencies (e.g., signal transmission delays between different control and protection layers) must be modelled.

HVDC_ACU_17

The actual **signal processing methods**, as implemented in the plant, must be included in the model:

- For example: RMS calculations, all filtering processes or any other type of frequency/angle estimation and all derived quantities based on instantaneous current and voltage measurements.
- These signal processing methods shall not be based on the native control block of the simulation tool, only "real code" (with the format and interface defined in [14.]) of the processing method is accepted.

5.4. Aggregation

HVDC_ACU_18

A detailed representation of the HVDC converters (including valves and all other installation components as defined in section 3) is required. **Aggregation is not permitted.**

HVDC_ACU_19

Main plant transformer and reactive compensation devices up to the PoC (e.g. switched shunts, harmonic filters, etc) must be individually represented.

6. Usability

6.1. Simulation Software Requirements

HVDC_USA_1

The EMT model shall run on the EMT simulation software specified by the TSO (Grid Code PC.A8.8). No additional toolboxes shall be required to run the model without agreement with the TSO.

This EMT model specification is intended to be “**software agnostic**”, however some commercial tools have specific features that can affect the compatibility and performance of the model. The following sub-sections address software specific requirements. Both software platforms listed below are acceptable.

6.2. PSCAD Requirements

HVDC_USA_2

If the PSCAD software is used to deliver the model, the specific requirements must be fulfilled:

- Be compatible with PSCAD version 5 or the version specified by the TSO.
- Be compatible with Intel Fortran Compiler version 19.2 and higher, and Visual studio 2019 and newer, compatible with 32-bit and 64-bit systems. It must also be executable with other versions of Intel Fortran – models that require GNU FORTRAN exclusively will not be accepted.
- Support the PSCAD “time snapshot” and “multiple run” features. In case the “snapshot” function is used, the model must provide the same response with or without snapshot usage.
- Not utilise multiple layers in the PSCAD environment, including ‘disabled’ layers.

6.3. EMTP Requirements

HVDC_USA_3

If the EMTP software is used to deliver the model, the specific requirements must be fulfilled:

- Be compatible with EMTP version 4.5 or the version specified by the TSO.
- The use of masks is encouraged to facilitate the usability of the model.

6.4. Packaging & Compatibility

HVDC_USA_4

It must be possible to copy the connected plant model, as defined in Layer 1 (Figure 1), and paste it into any other schematic implemented within the same EMT software without requiring any manual adaptation by the user to integrate the model into the new environment.

HVDC_USA_5

Any number of the connected plant models can be placed in the same scheme with the following rules:

- Multiple instances of the connected plant model should be able to run with or without parallel computing.
- It should be done without any manual adaptation of the model required by the user of the different instances in the simulation environment.

HVDC_USA_6

The model should produce the same results and behaviour whether it is used on its own or alongside models from other manufacturers within the same scheme, as long as they are not electrically connected in that scheme.

HVDC_USA_7

The model package shall include the plant model connected to a simplified model of the AC grid that can be adapted to site-specific PoC and equipment configuration. No specific requirement on the type of model is made.

HVDC_USA_8

The submitted **simulation model package** must include all files required to run a simulation, including a "model test case", and the model documentation defined in section 7.

- All control and protection functions must be provided in the "real code" format specified in the Cigre/IEEE TB 958 [14.] and interfaced with the plant model.
- Precompiled elements are forbidden (such as .lib, .obj, etc.), **only DLL files are accepted for control and protection functions.**
- The models should be configured to run without any manual adaptation by the user. For instance, location of any external references and files shall be specified with relative paths.
- When a new model version is submitted, the model package must contain all files required to run the simulation and the user guide documentation, the model design documentation should be resubmitted in case of changes to the model.
- All submitted files in the model package shall be identified with a name that includes a unique version identifier. When the model package is resubmitted for whatever reason (e.g. following an update), all corresponding files must be renamed with a new unique identifier.

HVDC_USA_9

All electrical components listed in section 3.2 shall be open and accessible.

All "black-boxed" control and protection functions (i.e. real code interfaced with Cigre/IEEE standard [14.]) must follow the same guidelines as all files submitted in the simulation model package described above.

6.5. Model Inputs, Configuration & Tuning

HVDC_USA_10

The use of global variables defined in the simulation environment is forbidden. If global variables need to be defined, it is required to use an external configuration file (.txt or .csv) for the connected plant.

HVDC_USA_11

Interface signals and parameters must be tuneable via the model operator HMI in Layer 2 (Figure 2). This functionality must be supported during both initialization and dynamic simulation, enabling seamless set-point changes at runtime without compromising numerical stability or control accuracy. Where applicable, all models must allow adjustment – both prior to and during a simulation run – of, at a minimum, the following parameters:

1. HVDC plant specific signal list including (but not restricted to):
 - Active power setpoint
 - Reactive power setpoint
 - AC voltage setpoint
2. Internal setpoints and/or parameters not included in the signal list, for example:
 - DC link voltage and current firing angle (for LCC HVDC only)
 - Switch / valve currents
 - Active and reactive currents
 - Quantity determining activation of blocking modes
 - Set-point for active power
 - Set-point for reactive power, voltage or power factor

- External protection relay(s) status

3. Control and protection modes and associated activation as listed in section 3.3

HVDC_USA_12

The model should be submitted with all available Frequency Reserve Modes and setpoints defined to reflect the actual configuration of the plant on site.

By default, Mode 1 must be active, and the user must be able to select or switch the active mode both before simulation start and during runtime.

Any user-settable option must reflect real hardware capabilities and must only expose control configurations that are valid at the actual site being modelled.

HVDC_USA_13

A table with version tracking shall be implemented in Layer 2 (Figure 2) of the model with reference to each model updated and changes made.

HVDC_USA_14

It must be possible to parametrize the model so it can reproduce any operating point of the plant (active power, reactive power, and voltage) in line with the grid code requirements.

6.6. Simulation Performance & Stability

HVDC_USA_15

The model must be capable of self-initialization. EMT models should initialize and ramp to the expected output without external input/actions from the user. Any slower control functions which are included (such as switched shunt controllers, transformer tap changers and other power plant controllers) should also accept initial condition variables if required.

HVDC_USA_16

The model must initialise and reach stable steady-state to any user defined and valid operating point in **less than 3 seconds of simulation time** for the full operating range of the plant (MW and MVar).

The voltage (RMS), frequency, active and reactive power measured at the PoC should remain constant ($\leq 0.1\%$ oscillatory behaviour) after the initialisation period during dynamic solution runs with no disturbances.

HVDC_USA_17

The model must be adequate for **simulation time steps within a range from 10 μ s to 50 μ s, with 10 μ s steps**. The model must not be restricted to running at one single defined time step and must allow the TSO to have the flexibility to change the simulation time step. Any accuracy limitations at larger time steps must be clearly flagged to the TSO in the model documentation.

HVDC_USA_18

Any unstable operation of the dynamic behaviour of the plant shall not result in crashing of the simulation, and any mechanism (protection etc.) that ceases the unstable operation shall reflect the actual power plant response.

6.7. Diagnostics & Outputs

HVDC_USA_19

Appropriate and clear warnings must be generated whenever the operating point violates defined thresholds or enters invalid operating condition.

HVDC_USA_20

The EMT model must provide at each marked node (see Figure 3), at a minimum, the following measurement signals (according to IEC 61400-21-1) and internally calculated by the measuring system of the plant:

- $V(t), I(t)$: 3 phase instantaneous and RMS voltage and current
- $V_{pos}, V_{neg}, V_{zero}$: Positive, negative and zero sequence voltages
- $I_{pos}, I_{neg}, I_{zero}$: Positive, negative and zero sequence currents
- I_{posd}, I_{posq} : Positive sequence current on d and q axes
- P, Q : Active and reactive power
- P_{pos}, Q_{pos} : Positive sequence active and reactive power
- $freq$: measured absolute frequency at each converter station
- $RoCoF$: Calculated rate-of-change-of-frequency at each converter station
- PLL input and output signals: frequency and angle
- Output of possible active damping functions such as sub-synchronous damping controllers (if applicable)
- Current in high impedance grounding system (if applicable)
- Instantaneous currents in each valve of the converter - 6 arms
- Sum of arm currents in each valve (positive + negative) or Circular currents (for MMC converters) - 3 phases
- DC voltages for each Converter Station: positive, negative poles and on neutral/DMR for bipolar configuration
- DC currents for each Converter Station: positive and negative poles and on neutral/DMR for bipolar configuration
- Active power order, and output from active power ramp if relevant
- Max/Min active power capacity limit (calculated based on $I_{dmax/min}$ signal and the measured AC voltage)
- Max/Min I_d current limit
- Reactive power order/ V_{ac} (AC voltage at PCC-AC) order, and slope
- Max/Min reactive power capacity limit (calculated based on $I_{qmax/min}$ signal and the measured AC voltage)
- Max/Min I_q current limit
- DC voltage reference
- Converter module max voltage of each valve - 6 arms (for MMC converters)
- Converter module min voltage of each valve - 6 arms (for MMC converters)
- Binary indicating if the converter is an Inverter or Rectifier if relevant
- I_{dq} references,
- Modulation index (for VSC converters)
- All voltage signal values will be provided in kV, current kA, active power in MW, reactive power in MVAR and measured frequency in Hz

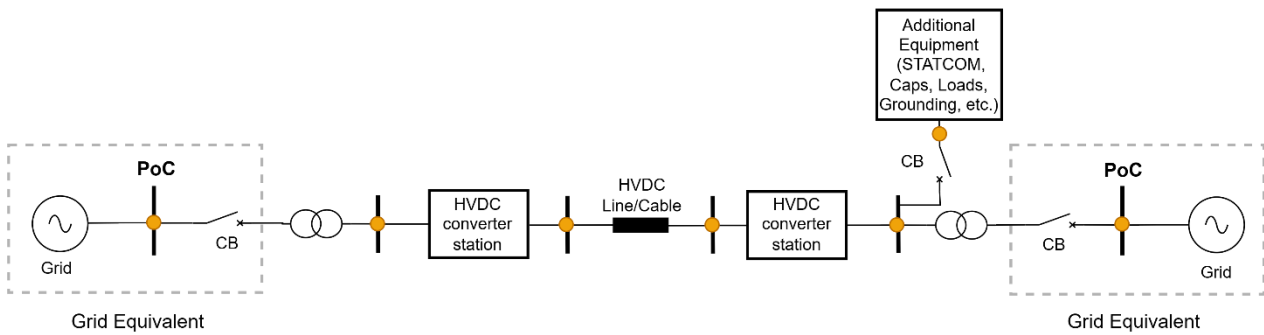

Figure 3: Measurement nodes in the EMT model

HVDC_USA_21

The following output signals must be available from the operator HMI in Layer 2 (Figure 2):

- Positions of all circuit breakers, grid connection, each feeder and the connected plant.
- Transformer tap changer position when applicable.
- Control mode in operation (e.g. Grid Forming or Grid Following, if applicable).
- Diagnostic signals (e.g., flags to show which protection has been activated and whenever the operating point violates defined thresholds or enters invalid operating conditions) and should clearly identify why a model trips during simulations. Note that this refers only to those error/status codes which translate into a distinct electrical system response at the low voltage (LV) terminals of the plant, for example, normal, fault, stop, low voltage ride-through (LVRT) or high voltage ride-through (HVRT) activation, unstable mode identification.

7. Documentation

7.1. Introduction

HVDC_DOC_1

The delivery of all EMT models must be accompanied with appropriate documentation with sufficient detail as specified by the TSO in this document (Grid Code PC.A8.3).

The following subsections specify the minimum information that must be included in the model documentation.

7.2. Model Overview and File Integrity

HVDC_DOC_2

The **Model User Guide** must include:

- The documentation Vendor name and version of the model.
- Version history of the plant model - including versioned filenames and a brief change log.
- Software requirements and version compatibility.
- Mapping of converter (if applicable) or plant firmware version to EMT model version.

- List and description of all the files being submitted in the Model Package.
- Declaration by the plant owner confirming site-specific representation.
- Guidance on simulation platform setup.
- Clear mapping of implemented vs. missing plant functions.
- Any missing logic must be flagged and justified to the TSO.
- Instructions for setup and initialization.
- Description of any possible limitations of the model for the required time step range defined in section 6.6.
- Instructions to change control modes (including all the intermediate steps) and parameter settings.
- List of model parameters, highlighting parameters affecting ride-through and grid support services, if applicable.
- Mapping of differences between on-site values and model parameters (with explanations) when applicable.
- Model applicability boundaries, including minimum system strength (SCR) below which the model is no longer stable and, minimum/maximum X/R ratio outside which the model is no longer stable.
- Description of the test case and all the simulation waveforms

7.3. Model Configuration and Technical Content

HVDC_DOC_3

Full list including description of interface signals, model parameters and output signals available in the model operator HMI (Layer 2 - Figure 2):

- Description of each signal including signal name, unit, measurement points for output signals, base value, and variable type
- Valid input ranges for interface signals and model parameters.
- Relevance of parameters and interface signals depending on the selected control mode.

7.4. Model Design Documentation

HVDC_DOC_4

Model Design documentation must be provided with the following:

- Plant single-line diagram (SLD) showing main components up to the PoC.
- Main circuit parameters and P,Q,U capabilities of the plant.
- Lengths, electrical and geometrical data of all high voltage cables and overhead lines required for EMT simulation modelling.
- Interface signal list for the exchange between the connected plant and the system operator.
- Control and protection philosophy of the plant (including auxiliary devices as defined in the section 3) and unit level.
- Transformer nameplate and saturation data, power frequency impedances calculated from short circuit and open circuit tests for all applicable tap changer positions
- Surge arrester data sheet

- Harmonic filter data sheet (if applicable)

7.5. Model Test Case Requirements

HVDC_DOC_5

The delivery of the EMT model must be accompanied by a **test case** such that the model can be tested before being integrated into the wide area model of the All Island network (Grid Code PC.A8.8). The "test case" must illustrate how to use the model with clear guidelines and results to compare.

- The test case model must be configured according to the site specific real equipment configuration and parameters up to the PoC.
- The test case must use a Single Machine Infinite Bus (SMIB) representation of the power system, as seen at the PoC using the Minimum System Strength (MSS) data provided by the TSO.
- A table with interface signals and model parameters used for each step of the test case must be provided.
- Time step used for the simulation must be clearly indicated.
- All waveforms of signals must be accessible from the model operator HMI (Layer 2 - Figure 2).

HVDC_DOC_6

Case simulated: 100 milliseconds solid single phase-A to ground fault at PoC of the connected plant. The fault is applied at the maximum of phase a voltage.

HVDC_DOC_7

The grid model and its parameters used are the ones supplied with the model package.

8. Delivery & Maintenance

8.1. General

HVDC_MAI_1

Model providers should confirm that they have model maintenance and support frameworks in place with vendors / suppliers for the duration of the designed asset operational lifetime to provide model updates and technical supports to Asset Owner and the TSO, as per Grid Code clause PC.A8.7. Should this requirement be not achievable either in practical or commercial terms, then further discussions with the TSO are required to seek alternative means of continued model maintenance and support.

HVDC_MAI_2

Technical support from the model supplier must be made available to support the TSO in setup and running simulation analysis and solve any relevant issues in case of non-compliance with any item of this EMT model specification.

- If any conflict is detected, it must be resolved through the system operator's procedure (e.g., meeting or email), always respecting model and data confidentiality.
- The duration of the model support shall be available as long as the plant is connected to the grid.

HVDC_MAI_3

If the plant includes additional equipment or extensions of a different type - hybrid plant - (e.g. STATCOM, synchronous condenser, or auxiliary generation, energy storage, etc.), these components shall be represented according to their own applicable specification described in a separate document.

A single joint model is expected to represent the complete plant. However, this may be provided as a set of separate but interconnected models, as long as the interaction and integration between all components is correctly captured and aligned with system-level behaviour.

8.2. Model Delivery Timeline & Scope of Delivery

HVDC_MAI_4

Preliminary model:

- comprises the preliminary model and documentation (user guide) with preliminary settings of the plant;
- 12 months before first energization of the plant.

HVDC_MAI_5

Final model:

- Final model and documentation (user guide + design);
- with final settings as implemented on site as default;
- 3 months before first energization of the plant.

8.3. Model Maintenance

HVDC_MAI_6

All Models provided by the TSO must be maintained and updated to accurately reflect the operational performance of the User's plant **over the lifetime of the plant** (Grid Code PC.A8.7).

Every time there is a modification on site (e.g. equipment, control and protection hardware and software, settings or interface signals), minor or major, that has material impact on the behaviour of the plant in steady state or during transients, a complete model package must be resubmitted in a timeframe agreed with the TSO (typically, no later than 1 month after modifications have been implemented on site).

HVDC_MAI_7

Any update of the model submitted shall comply with the most up-to-date EMT model specification published by the TSO.

HVDC_MAI_8

The TSO may from time-to-time request that the models be updated to be compatible with changes in the TSO's computing environment, namely software version and/or compiler version. The plant owner shall ensure that such updated models are provided without undue delay or in any event, within 90 Business Days of the date of the request. (Grid Code PC.A8.8)

8.4. Model Checklist

HVDC_MAI_9

A complete checklist (see Appendix A: Model Checklist) must be submitted to the TSO confirming compliance with the specifications described in this document.

9. References

- [1.] EirGrid Grid Code v14.2 (July 2024)
- [2.] Commission Regulation (EU) 2016/1447 of 14 April 2016 establishing a network code on requirements for grid connection of high voltage direct current systems and direct current-connected power park modules
- [3.] [ACER Recommendation 01-2024 on NC HVDC](#)
- [4.] NERC Reliability Guideline: Electromagnetic Transient Modelling for BPS-Connected Inverter Based Resources - Recommended Model Requirements and Verification Practices (March 2023)
- [5.] Electranix PSCAD Model Requirements Rev 12 (September 2022)
- [6.] CAISO EMT Modelling Requirements (April 2021)
- [7.] FINGRID Modelling instruction for PSS/E and PSCAD models (January 2024)
- [8.] AEMO Power System Modelling Guidelines (July 2023)
- [9.] REE Requisitos de los modelos EMT (June 2023)
- [10.] NGESO Guidance Notes for Electro-Magnetic Transient (EMT) Models (January 2023)
- [11.] ENERGINET REQUIREMENTS FOR GENERATORS (RFG) - SIMULATION MODEL REQUIREMENTS (September 2024)
- [12.] French Grid code for PPM - "Cahier des charges des capacités constructives - Conditions générales - Parc non synchrones de générateurs" Section 3.11.2 available online: https://servicesrte.com/files/live//sites/services-rte/files/documentsLibrary/20241225_DTR_7401_f
- [13.] CIGRE Technical Brochure 604 "Guide for the Development of Models for HVDC Converters in a HVDC Grid". December 2014. Available online at: <https://www.e-cigre.org/publications/detail/604-guide-for-the-development-of-models-for-hvdc-converters-in-a-hvdc-grid.html>
- [14.] CIGRE/IEEE Technical Brochure 958 "Guidelines for use of real-code in EMT models for HVDC, FACTS and inverter based generators in power systems analysis". February 2025. Available online at: <https://www.e-cigre.org/publications/detail/958-guidelines-for-use-of-real-code-in-emt-models-for-hvdc-facts-and-inverter-based-generators-in-power-systems-analysis.html>
- [15.] CIGRE Technical Brochure 766 "Network modelling for harmonic studies". April 2019. Available online at: <https://www.e-cigre.org/publications/detail/766-network-modelling-for-harmonic-studies.html>

10. Appendix

10.1. Appendix A: Model Checklist

This appendix is a EMT model checklist which must be completed by the plant owner and submitted alongside the EMT model.

Plant model identification		
Model submission Date		
Plant project name		
Primary contact information for model related questions		
List of EMT model files submitted		
List of documents submitted		
Plant model specification checklist		
2. Intended use		Model Complies? (Y, N, N/A, comments)
2.1	HVDC_INT_1	
2.2	HVDC_INT_2	
2.2	HVDC_INT_3	
2.2	HVDC_INT_4	
2.3	HVDC_INT_5	
2.3	HVDC_INT_6	
3. Components		Model Complies? (Y, N, N/A, comments)
3.1	HVDC_COM_1	
3.1	HVDC_COM_2	
3.2	HVDC_COM_3	

3.3	HVDC_COM_4	
3.3	HVDC_COM_5	
3.3	HVDC_COM_6	
3.3	HVDC_COM_7	
3.3	HVDC_COM_8	
3.4	HVDC_COM_9	
4. Structure		Model Complies? (Y, N, N/A, comments)
4.1	HVDC_STR_1	
4.2	HVDC_STR_2	
4.3	HVDC_STR_3	
4.4	HVDC_STR_4	
4.4	HVDC_STR_5	
4.5	HVDC_STR_6	
5. Accuracy		Model Complies? (Y, N, N/A, comments)
5.1	HVDC_ACU_1	
5.1	HVDC_ACU_2	
5.1	HVDC_ACU_3	
5.1	HVDC_ACU_4	
5.2	HVDC_ACU_5	
5.2	HVDC_ACU_6	
5.2	HVDC_ACU_7	
5.2	HVDC_ACU_8	
5.2	HVDC_ACU_9	
5.2	HVDC_ACU_10	
5.2	HVDC_ACU_11	

5.2	HVDC_ACU_12	
5.2	HVDC_ACU_13	
5.2	HVDC_ACU_14	
5.3	HVDC_ACU_15	
5.3	HVDC_ACU_16	
5.3	HVDC_ACU_17	
5.4	HVDC_ACU_18	
5.4	HVDC_ACU_19	
6. Usability		Model Complies? (Y, N, N/A, comments)
6.1	HVDC_USA_1	
6.2	HVDC_USA_2	
6.3	HVDC_USA_3	
6.4	HVDC_USA_4	
6.4	HVDC_USA_5	
6.4	HVDC_USA_6	
6.4	HVDC_USA_7	
6.4	HVDC_USA_8	
6.4	HVDC_USA_9	
6.5	HVDC_USA_10	
6.5	HVDC_USA_11	
6.5	HVDC_USA_12	
6.5	HVDC_USA_13	
6.5	HVDC_USA_14	
6.6	HVDC_USA_15	

6.6	HVDC_USA_16	
6.6	HVDC_USA_17	
6.6	HVDC_USA_18	
6.7	HVDC_USA_19	
6.7	HVDC_USA_20	
6.7	HVDC_USA_21	
7. Documentation		Model Complies? (Y, N, N/A, comments)
7.1	HVDC_DOC_1	
7.2	HVDC_DOC_2	
7.3	HVDC_DOC_3	
7.4	HVDC_DOC_4	
7.5	HVDC_DOC_5	
7.5	HVDC_DOC_6	
7.5	HVDC_DOC_7	
8. Delivery & Maintenance		Model Complies? (Y, N, N/A, comments)
8.1	HVDC_MAI_1	
8.1	HVDC_MAI_2	
8.1	HVDC_MAI_3	
8.2	HVDC_MAI_4	
8.2	HVDC_MAI_5	
8.3	HVDC_MAI_6	
8.3	HVDC_MAI_7	
8.3	HVDC_MAI_8	
8.4	HVDC_MAI_9	