

Harmonics Workshop for TSO and DSO customers

21st November 2013

Alexander Hotel, Fenian St, Dublin 2



Agenda for Harmonics Workshop



Session 1

10:00

- Introduction (*Yvonne Coughlan*)

10:10

- Background Theory and Grid Code (*John Ging*)

10:40

- International Standards and Practice (*Zia Emin*)

11:05

- Tea Break

11:15

- TSO Policy & Proposed Methodology for limit calculation (*Mark Norton*)

12:00

- DSO Policy & Proposed Methodology for limit calculation (*Ivan Codd*)

12:30

- Q+A

Session 2

13:45

- Mitigation strategies (*Marta Val Escudero*)

14:05

- Power Quality monitoring (*Ray Doyle*)

14:15

- Charging (*Marie Hayden*)

14:40

- TSO Study Roadmap and Action Plan (*Brendan Kelly*)

15:10

- Q+A

15:25

- Closing Remarks (*Michael Walsh*)





Session 1



NETWORKS

Harmonic Theory

Dr. John Ging
EirGrid



What are Harmonics?



Defⁿ:

Any overtone accompanying a fundamental tone at a fixed interval

- “Artificial” but are always present in reality
- Characteristic depends on system – guitar *vs* violin sound
- Pleasing to the ear **but NOT for Power Systems**



Grid Code Requirements



CC.10.13 Power Quality

- **Users** shall ensure that **their connection** to the Transmission System **does not result in the level of distortion** or fluctuation of the supply Voltage on the Transmission System, at the Connection Point, **exceeding that allocated to them following consultation with the TSO.**
- **Distortion and fluctuation limits** are outlined in **IEC/TR3 61000-3-6 (Harmonics)** and IEC/TR3 61000-3-7 (Voltage fluctuation). Users shall also operate their Plant in a manner which will not cause the requirements contained in CENELEC Standard EN 50160 to be breached.



What are Power System Harmonics?



- Electrical signals occurring at integer multiples of the fundamental 50Hz power system frequency are known as harmonics
- Harmonics result in a periodic power system waveform distortion
 - Destroy the smooth sinusoidal curve

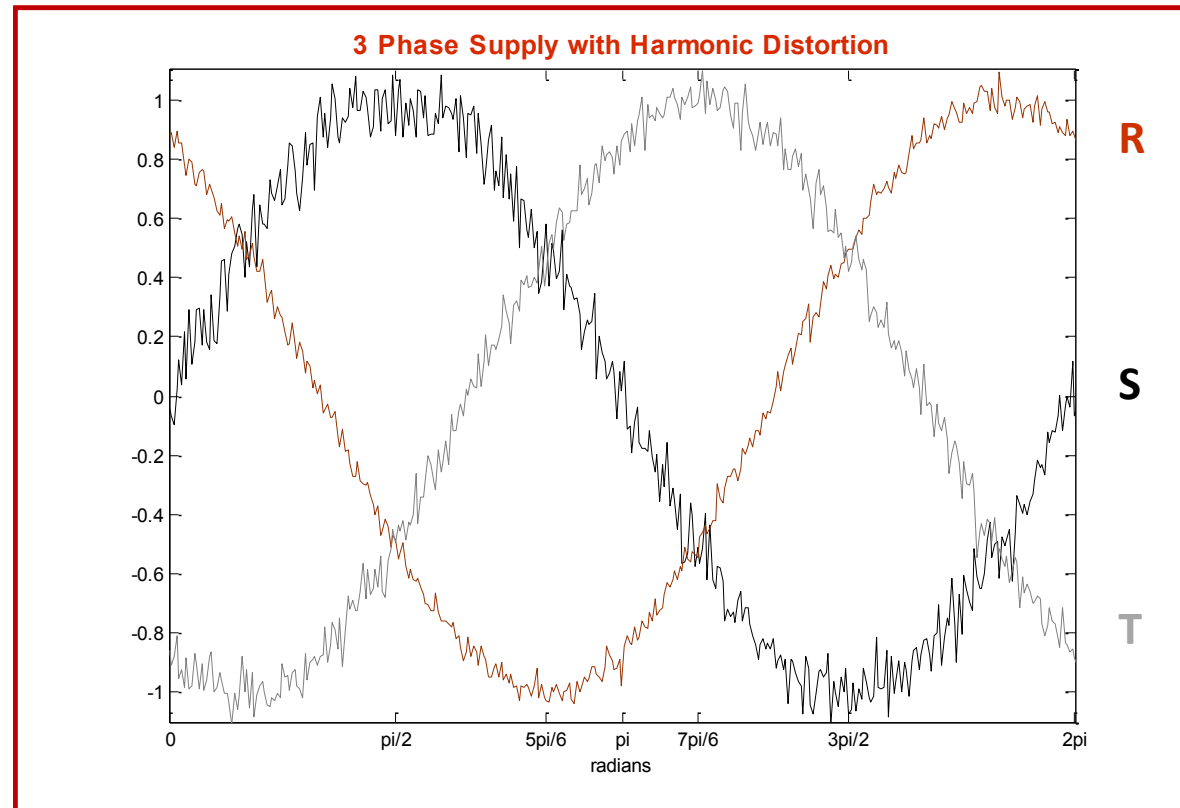

What are Power System Harmonics?



- Periodic functions $f(t)$ can be expressed as the sum of sines and cosines (Fourier series)

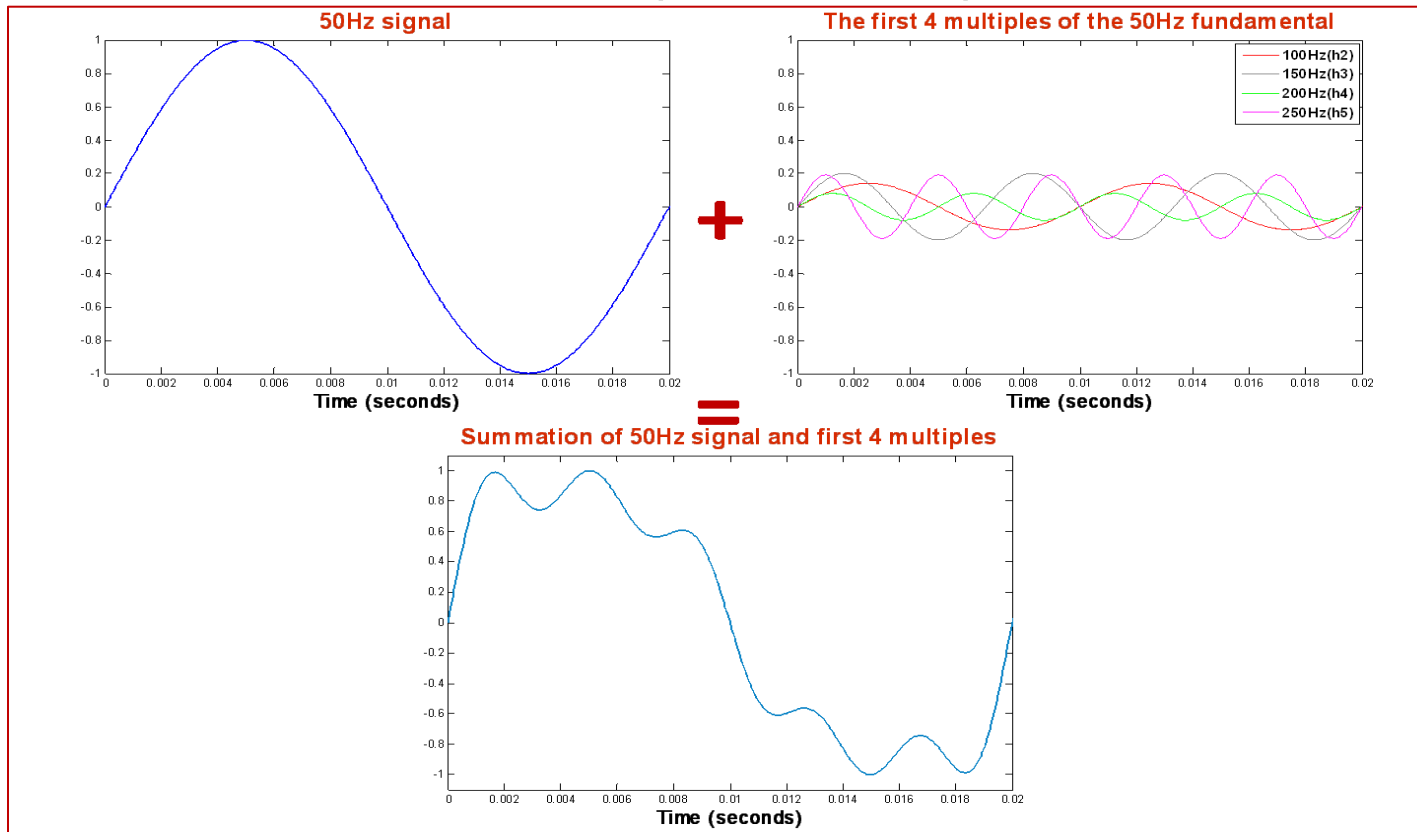

What are Power System Harmonics?



Recap of Fourier Analysis

- Reduces a convoluted integral in the **time domain** into a simple product in the **frequency domain**

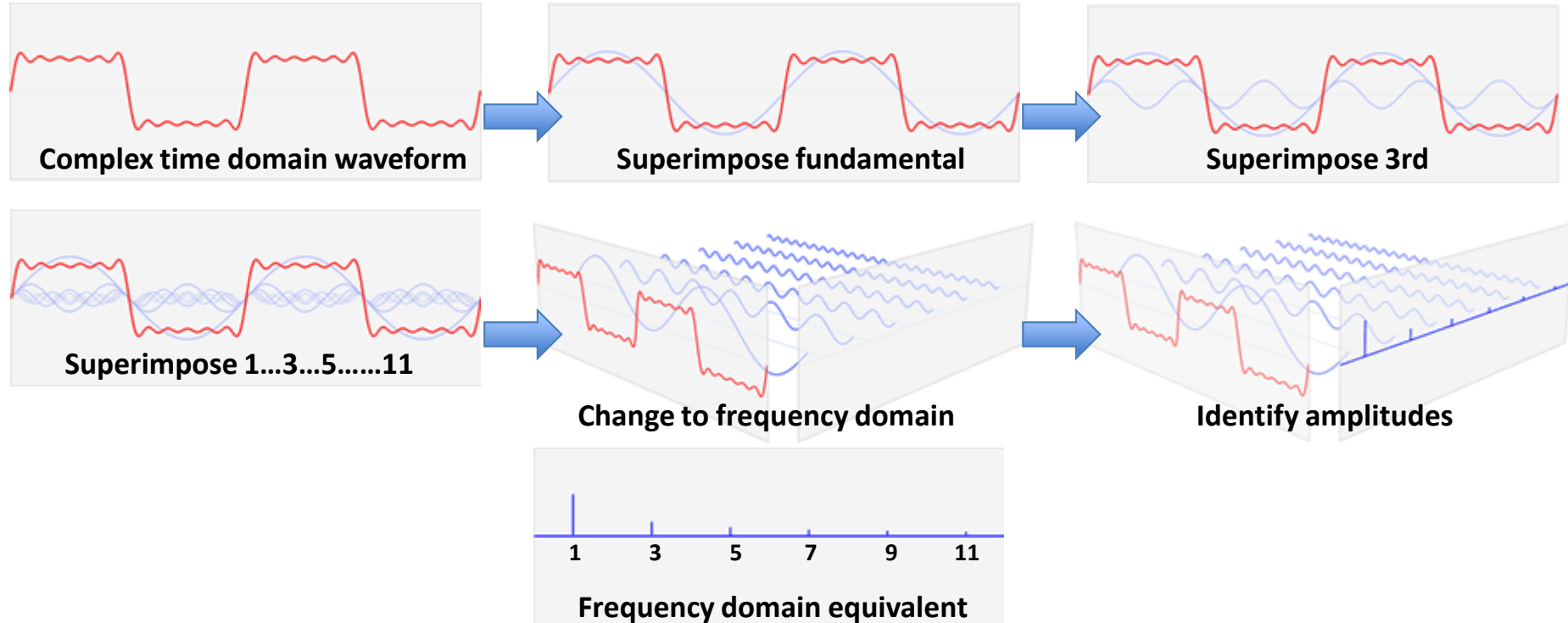

- Use a kernel of $e^{-j\omega t}$ in an integral transform of $f(t)$

Can analyse each harmonic order separately



What causes harmonics?



- **Caused by the non-linearity of customer loads**

- A result of devices drawing non-sinusoidal current from a sinusoidal voltage source

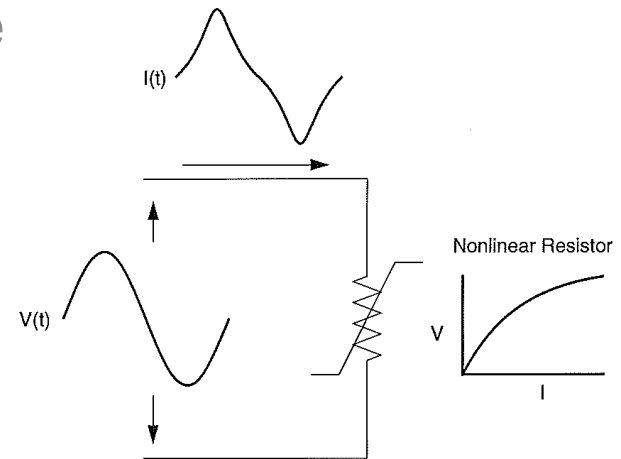

- These non-linear loads generate harmonic currents which interact with the system impedance instigating a harmonic voltage distortion.

Power System Harmonic distortion



Effect of Harmonic Orders

- Total Harmonic Distortion (*THD*) acts as a measure for the effective value of the harmonic components of a distorted waveform relative to the fundamental
 - Potential heating value of the harmonics
 - Can be referenced by either current or voltage

$$THD = \frac{\sqrt{\sum_{k=2}^{\infty} V_n^2}}{V_1}$$

Linear Waveform

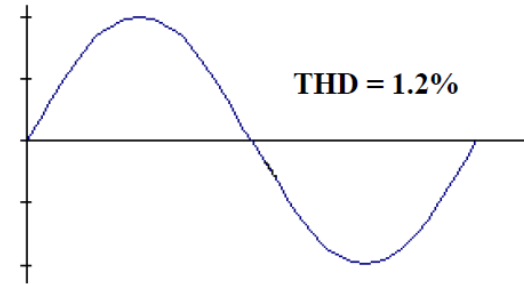

Non-Linear Waveform

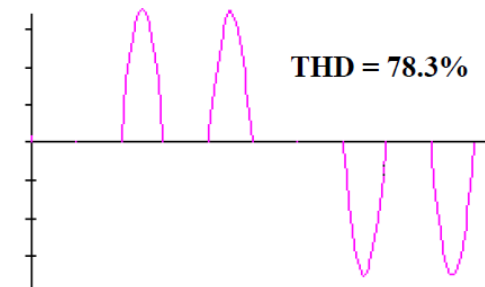

What are the harmonic sources?



Power Electronics	ARC devices	Saturated ferromagnets
<i>Power converters , rectifiers</i>	<i>Fluorescent lighting</i>	<i>Transformers</i>
<i>Variable frequency drives</i>	<i>ARC furnaces</i>	<i>Motors</i>
<i>DC motor controllers</i>	<i>Welding machines</i>	<i>Generators</i>
<i>Static var Compensators</i>		
<i>Power supplies, UPS and Battery Chargers</i>		
<i>Inverters</i>		

$kn \pm 1$ ($k_{pulses} = \{6, 12, 18\}$)	Broad spectrum	Lower frequencies
5 th , 7 th , 11 th , 13 th , 17 th , 19 th ...	2 nd , 3 rd , 4 th , 5 th , 7 th , 11 th	2 nd *, 3 rd , 4 th , 5 th , 6 th *, 7 th
Odd only	Even & Odd	Even & Odd



Why are Harmonic problems becoming an increasing concern?



- Increasing use of power electronics and converters (particularly for wind turbines) are injecting more harmonic currents onto the system
- The nature of the system is changing → system strength
- The influx of more cables onto the network **exacerbate** the problem by changing the network impedance
- **Cables amplify any harmonic injections present**



What does this mean?



Harmonic related distortions can result in the failure or mal-operation of end-use equipment

- Increases the current in the system (i.e. higher losses)
- Overheating in transformers, motors and neutral wires
- Can resonate with system Capacitor Banks
- Shaft torsion and shaft currents if un-insulated bearings
- Telecommunications interference
- Misfiring from incorrect triggering at “zero-crossings”
 - i.e. multiple crossings of the x-axis can wreak havoc on the timing signals used for Digital Circuits; Rectifiers, Thyristors and Inverters



Harmonic disturbances

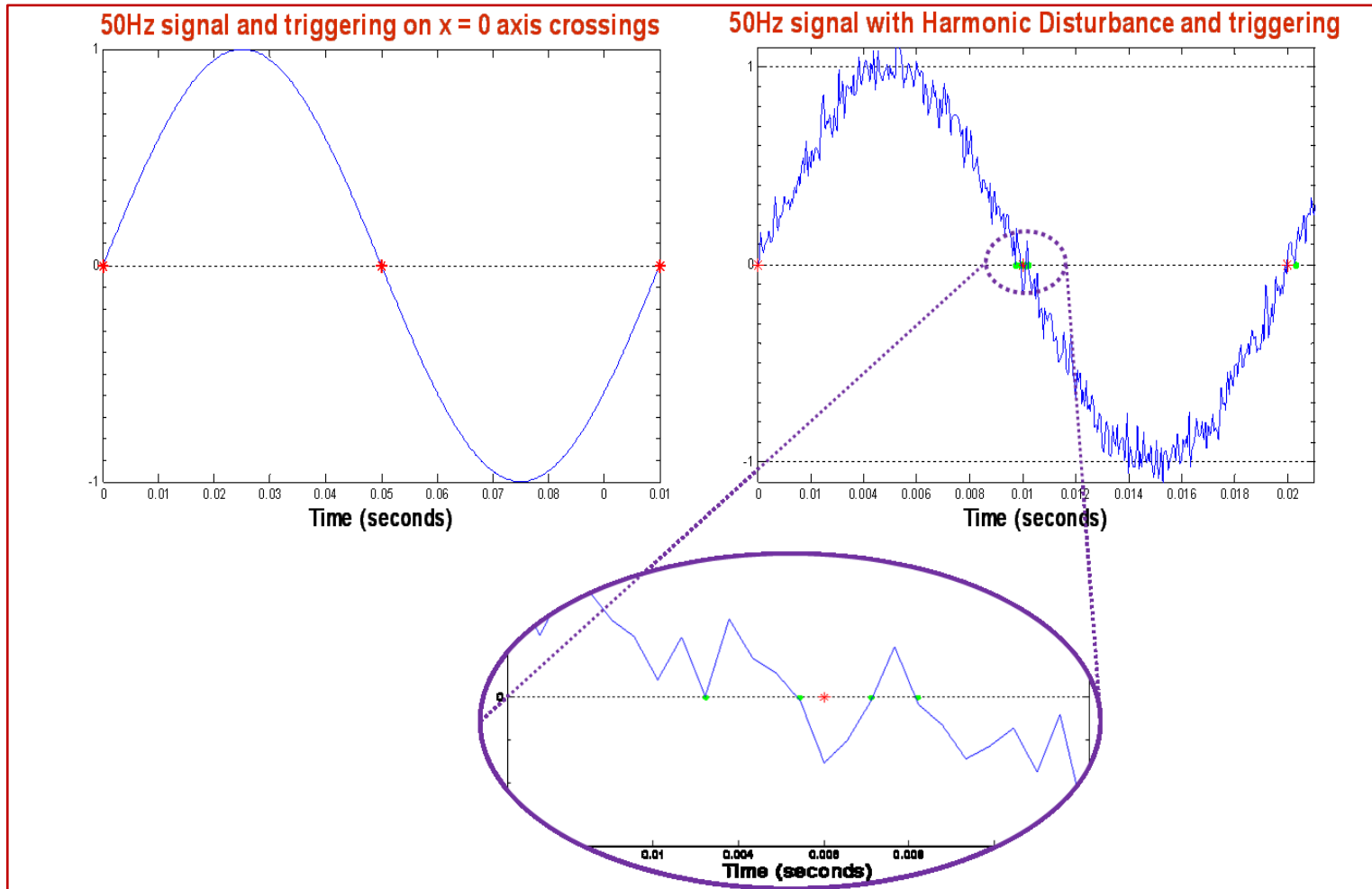

Types of resonances



- Parallel resonance:** parallel combination of capacitance and the system impedance is equal in magnitude at or near a harmonic frequency (Excited by Harmonic Current Source)
 - Impedance seen by harmonic current source becomes infinite
 - Substantial increase of harmonic current flowing between the capacitors and system inductance
 - Capacitor failure or transformer overheating

$$f_n = \frac{1}{2\pi\sqrt{L \cdot C}}$$

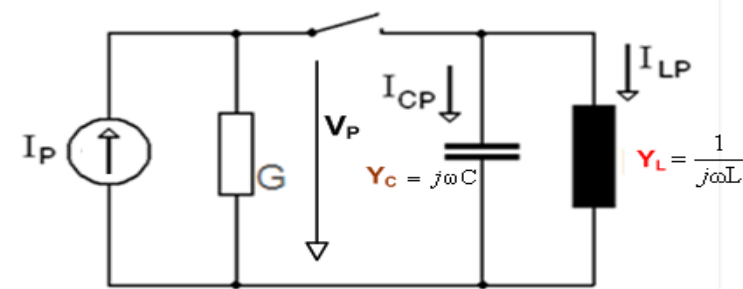
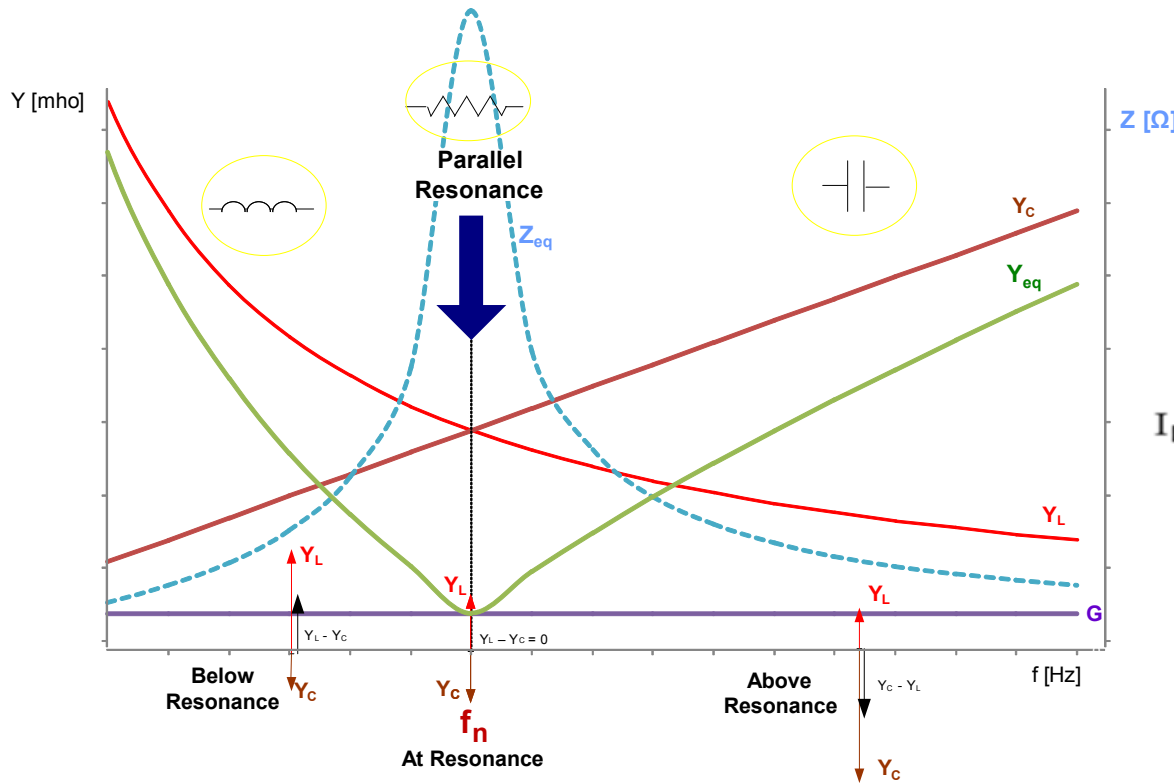

Types of resonances

- **Series resonance:** series combination of inductance and capacitance to present a low impedance path for harmonic currents at a specified frequency (Excited by Harmonic Voltage Source)
 - Impedance approaches 0
 - A high voltage distortion level manifests between the inductance and capacitance
 - Problem even if miniscule harmonic current injections

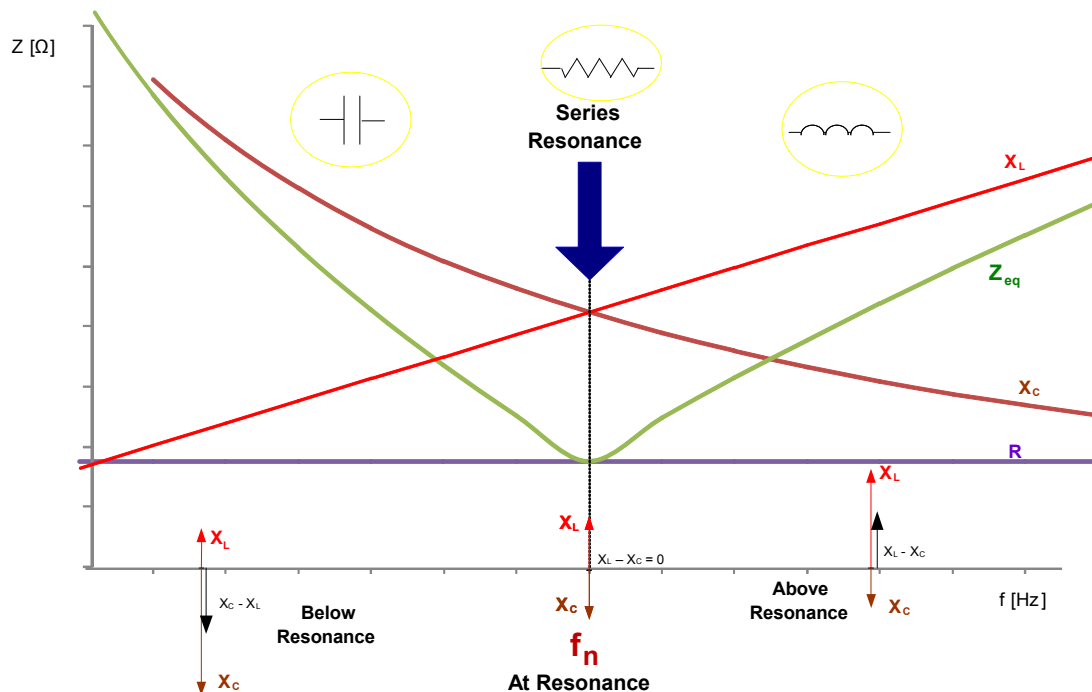

$$f_n = \frac{1}{2\pi\sqrt{L \cdot C}}$$

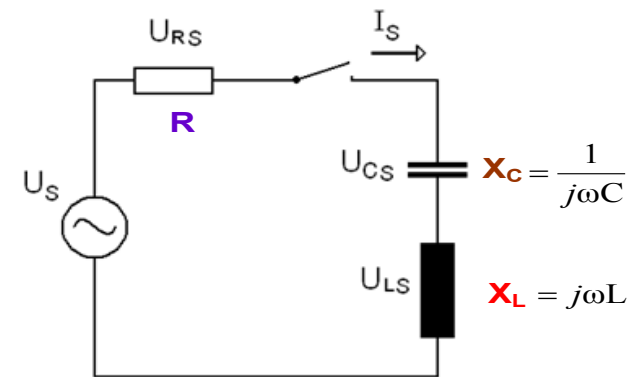

Impact on Customer connections



Study sequence of scenarios for harmonic issues:

1. At the transmission node [due to the connection method]

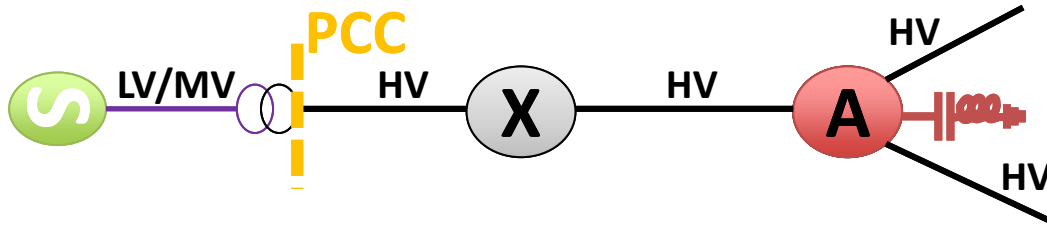

2. At the connection point [due to the customers site]

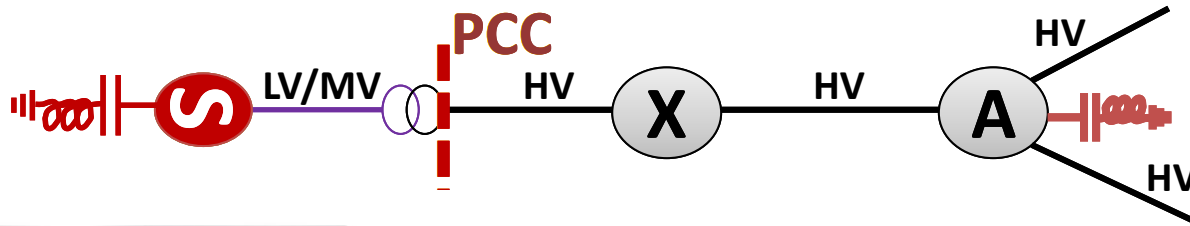

Impact on Cluster connections



Study sequence of scenarios for harmonic issues:

1. At the transmission node [due to the connection method(s)]

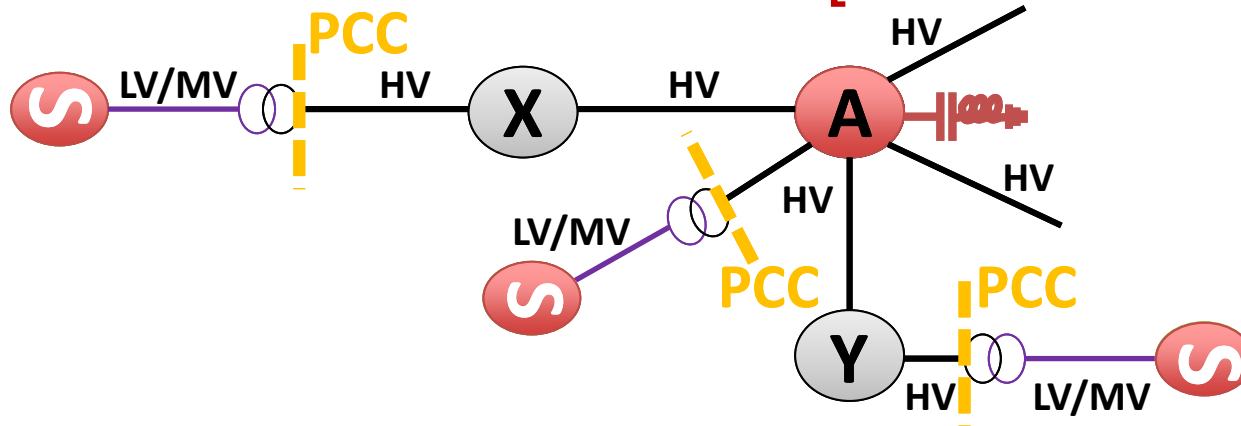

2. At the connection point [due to the customers site]

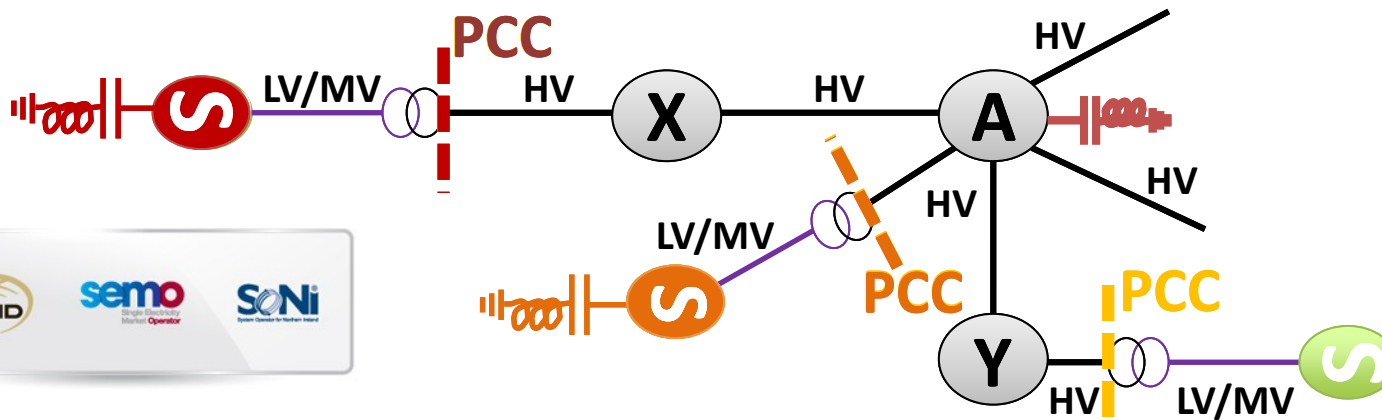

Details can also be found in the Harmonics Information notes:

<http://www.eirgrid.com/customers/gridconnections/harmonics/>



Harmonics in Power Systems

Zia Emin PhD, CEng, FIET, SMIEEE
Chief Engineer, Power Systems

Structure of Presentation

Why are we bothered about harmonics?

EMC concept and standards

What can we do about harmonics?

ER G5/4-1 Stage 3 Assessment

Specifying emission limits to customers

Higher frequencies?

Why is it important?

Ultimately, **ECONOMICS** is the main driver

- Poor power quality leads to suffering of business



LEONARDO ENERGY
POWER QUALITY

European Power Quality Survey

POOR POWER QUALITY COSTS
EUROPEAN BUSINESS MORE THAN
€150 BILLION A YEAR

Some historical economic data

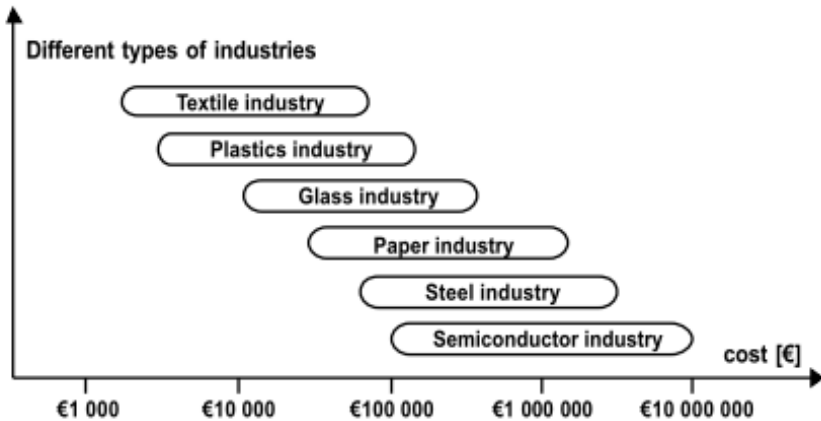

T. Andersson and D. Nilsson "Test and evaluation of voltage dip immunity," STRI AB and Vatenfall AB, 2002

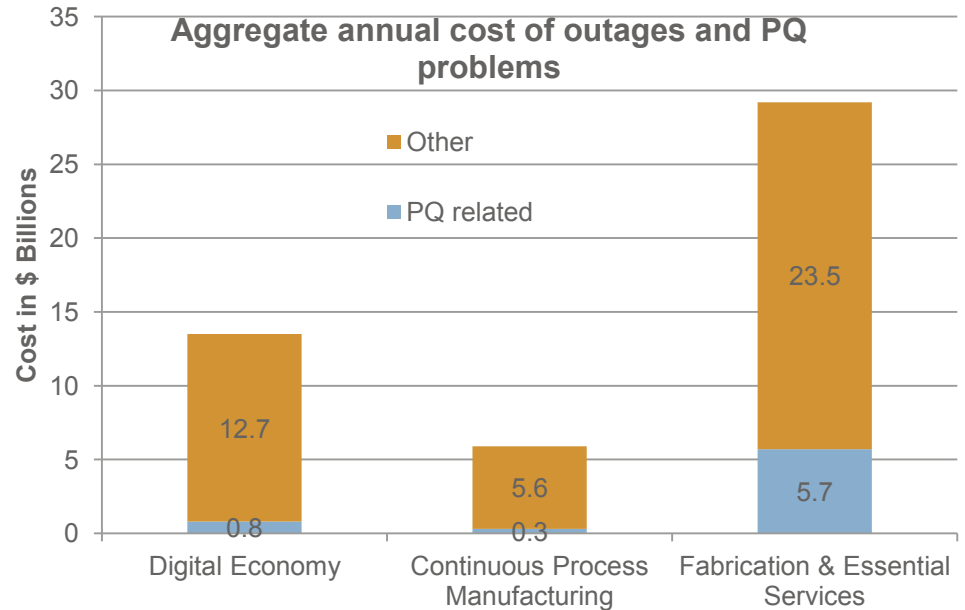

D Lineweber and S R McNulty "The cost of Power Disturbances to Industrial & Digital Economy Companies". Primen report for EPRI's (CEIDS), 2000

What can we do about them?

- **Standards and/or recommendations exists to make sure equipment connected to electricity supply system operate under a coordinated electromagnetic compatibility (EMC) criteria.**
- **Such standards and recommendations usually provide a set of planning and/or compatibility levels to be applied by system planners/operators.**

Why Standardize?

To make sure that equipment connected to electricity supply system operate under a **coordinated electromagnetic compatibility (EMC) criteria**.

Such standards and recommendations usually provide a set of **planning and/or compatibility levels** to be applied by system planners/operators.

Emission – Planning – Compatibility - Immunity

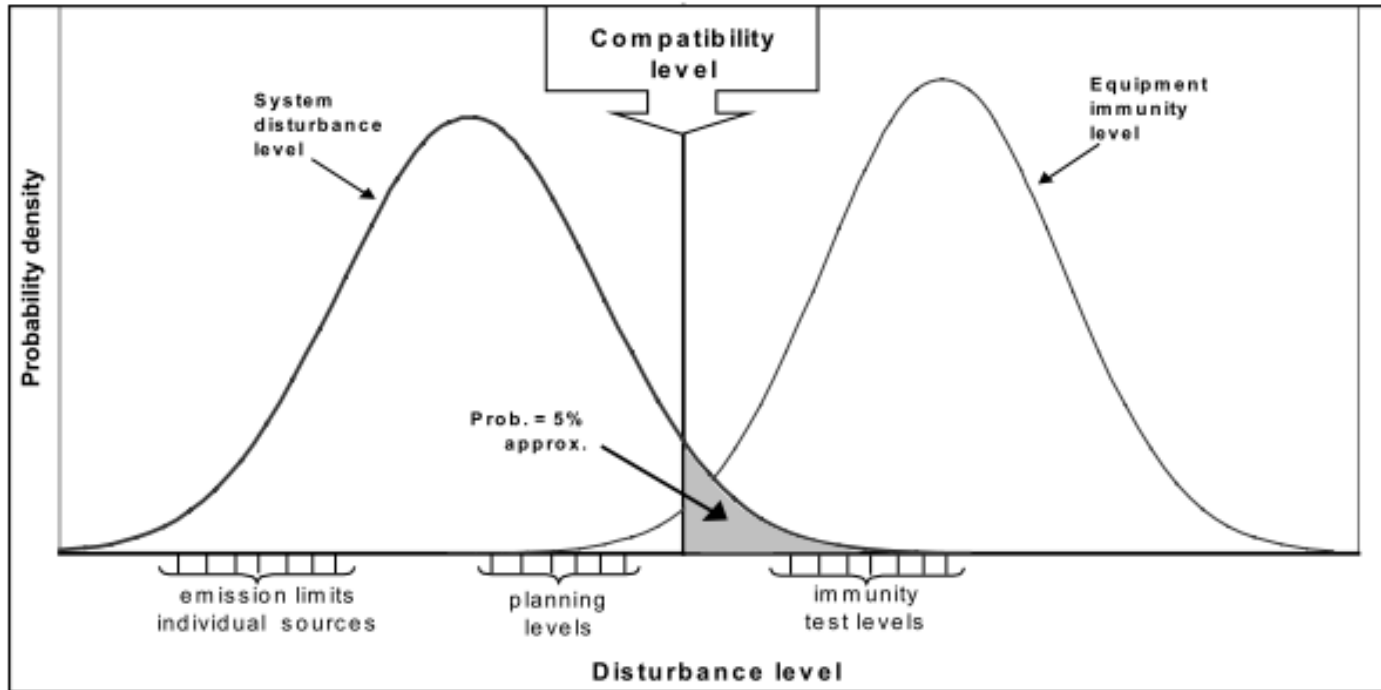

Main Documents on Harmonics

ER G5/4-1	
IEC TR 61000-3-6	
IEEE 519	
BS EN 50160	BS EN (IEC) 61642
BS EN (IEC) 61000-2-2	BS EN (IEC) 61000-2-12
BS EN (IEC) 61000-2-4	IEC TR 61000-2-6
BS EN (IEC) 61000-3-2	BS EN (IEC) 61000-3-12
IEC TR 61000-3-4	
BS EN (IEC) 61000-4-7	BS EN (IEC) 61000-4-30

Various Harmonic Standards

Recognized as an American National Standard (ANSI)

IEEE
(Revision of I)

IEEE Recommended Practices and Requirements for Harmonic Control in Electrical Power Systems

Circuits and Devices

Communications Techno

Computer

Electromagnetics and Radiation

Energy and Power

Industrial Applications

Signals and Applications

IEEE Industry Applications Society/
Power Engineering Society

Co-sponsored by the
Static Power Converter Committee and the
Transmission and Distribution Committee

Published by the Institute of Electrical and Electronics Engineers, Inc., 345 East 47th Street, New York, NY 10017-2199
April 12, 1992

COPYRIGHT © IEC. NOT FOR COMMERCIAL USE OR REPRODUCTION



IEC/TR 61000-3-6

TECHNICAL REPORT

BASIC EMC PUBLICATION

Electromagnetic compatibility (EMC) –
Part 3-6: Limits – Assessment of emission limits for the connection of non-linear equipment to transmission systems and distribution networks in the United Kingdom



Engineering
Recommendation G5/4-1

PLANNING LEVELS FOR
HARMONIC VOLTAGE
DISTORTION AND THE
CONNECTION OF NON-
LINEAR EQUIPMENT TO
TRANSMISSION SYSTEMS
AND DISTRIBUTION
NETWORKS IN THE UNITED
KINGDOM

OCTOBER 2005

Energy Networks Association
Engineering Directorate

IEEE Std 519-1992

IEC/TR 61000-3-6:2008(E)

.....a word of caution

Recommendations , Technical Reports and Standards.

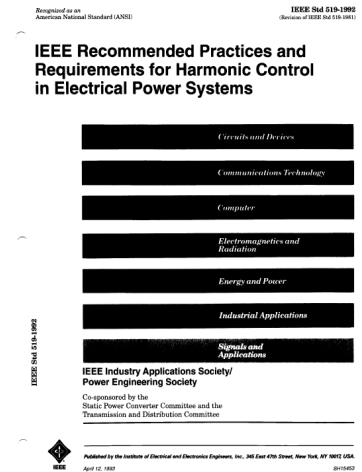

Not a STANDARD – it is, as name suggests, a RECOMMENDATION

Sets the planning levels with respect to harmonic voltage distortion compatibility levels to be used in the process for the connection of non-linear equipment for systems above 36.5kV. For systems less than 36.5kV the compatibility levels are set by International Standards.

It's application is referred to in Grid Code CC.6.1.5(a) and Distribution Code DPC4.2.3.2

Operates under the “first come first served” philosophy.

Not a STANDARD – it is, a Technical Report.

Limits – Assessment of emission limits for the connection of distorting installations to MV, HV and EHV power systems

Informative in its nature but provides guidance on principles which can be used as the basis for determining the requirements for the connection of distorting installations to MV, HV and EHV public power systems.

MV is $1 \text{ kV} < U_n \leq 35 \text{ kV}$

HV is $35 \text{ kV} < U_n \leq 230 \text{ kV}$

EHV is $U_n > 230 \text{ kV}$ (UHVAC, referring to 1000 kV UHVDC, referring to +/-800 kV)

Sets indicative planning levels for harmonic voltages in MV, HV and EHV power systems. No compatibility in IEC for HV and EHV.

Operates under the proportional allocation philosophy.

A STANDARD – it is recognised as such by ANSI.

IEEE Recommended Practices and Requirements for Harmonic Control in Electrical Power Systems

Based on developed current limits starting from LV all the way up. It also includes voltage limits applicable to all voltage levels. One limit level for all individual harmonics plus a separate one for THD.

Perhaps a bit outdated (1992) compared to ER G5/4-1 and IEC 61000-3-6 but still heavily used.

Comparison of IEC 61000-3-6 (1)

IEC 61000-3-6	ENA ER G5/4
<p>Stage 1 Based on:</p> <ul style="list-style-type: none">1- agreed power as the connection condition2- sum of weighted distorting power as the connection condition. This condition applies to cases where a connection has a number of distorting loads. <p>If the ratio (a) or (b) expressed as a percentage of the short circuit level at the connection point is below 0.2% then connection is allowed without any detailed studies.</p>	<p>ER G5/4 does not use simplified Stage 1 assessment for voltage levels at and above 33kV but it does allow for a simplified assessment in Stage 2.</p>

Comparison of IEC 61000-3-6 (2)

IEC 61000-3-6	ENA ER G5/4
<p>Stage 2 - detailed analysis</p> <ol style="list-style-type: none">1- Establish the total available power at the PoC and also at neighbouring substations in the considered region. Summate all outgoing powers (non-disturbing loads) plus any disturbing loads at PoC. The main text does not state the extent of the considered area, but the appendices indicate at least 2-3 nodes away from the PoC need to be considered.2- Calculate influence coefficients from the neighbouring substations to the PoC. These coefficients represent harmonic distortion achieved at the PoC when 1pu harmonic current is injected at the remote substation.3- Multiply each influence coefficient with the associated available power from neighbouring substation and summate them to give a regional total power. A ratio is then obtained using the available power at the PoC and the regional power. Use summation law, the ratio and the planning level to calculate a globally level available at the PoC.4- The customer is then allocated a portion from this global available limit based on his supply rating and the available power at the PoC. <p>The above process establishes a global level that could be available for a given substation ensuring that planning levels are not exceeded in the neighbouring substations. The approach then allocates rights based on the rating of the distorting loads.</p>	<p>Stage 3 process of the ER G5/4 is the closest to IEC Stage 2 approach. Both require the consideration of neighbouring substations. However, a significant difference exists between the two because ER G5/4 Stage 3 explicitly requires measurement of existing background distortions on the site and to utilise this information in establishing harmonic levels. IEC is not explicit in its treatment of background distortion.</p> <p>IEC states that at least 2-3 nodes away from the PoC should be considered, whereas ER G5/4 states that neighbouring nodes should extend to LV networks.</p> <p>The allocation of harmonic emissions in ER G5/4 is not based on the proportion of the distorting load but rather it gives all the available headroom to the first customer (“1st come 1st served” principle).</p> <p>ER G5/4 requires that regardless of the level of distortion present on the network before the connection, the customer who is requesting a connection for the distorting equipment must pay for all the expenditure to meet the harmonic requirements.</p>

Comparison of IEC 61000-3-6 (3)

IEC 61000-3-6	ENA ER G5/4
<p>Stage 3: This deals with acceptance of higher emission levels on a conditional basis. The reasoning is based on the following:</p> <p>Some installations do not produce significant harmonics and therefore available supply capacity of the system may not be used.</p> <p>General summation law is too conservative in some cases. In real systems distorting installations can produce harmonics with opposite phase.</p> <p>Some distorting installations do not operate simultaneously due to system or load constraints.</p> <p>When appropriate the system operator or owner may decide to allocate higher emission limits under Stage 3 considering pre-existing harmonics and new harmonics expected.</p>	<p>ER G5/4 also makes suggestions to deal with situations where harmonic levels may exceed planning levels. However, due to the apportioning method established in the IEC, this becomes more evident in the IEC approach to accept higher emission levels. This is because the limit allocated (reflective of customer capacity and substation capacity) already has an inherent margin below the global limit for the substation. In ER G5/4, all the available head room is allocated to the first customer and therefore it is not straight forward to establish if spare margin will be available for the same reasoning made in the IEC.</p> <p>ER G5/4 does state that in cases where planning levels may be exceeded due to connection of new load, this should be reflected in the connection agreement and the connection can be objected until an agreement is reached between the customer and network owner.</p> <p>ER G5/4 refers to ETR 122 for remedial measures. The remedial measures are given for both customer and network owner.</p>

What else is there for harmonics?

BS EN 61000-2-2
(IEC)

BS EN 61000-2-4
(IEC)

BS EN 61000-2-12
(IEC)

IEC TR 61000-2-6

BS EN 61000-3-2
(IEC)

BS EN 61000-3-12
(IEC)

IEC TR 61000-3-4

IEC TR 61000-3-5

IEC TR 61000-3-14

BS EN (IEC) 61000-4-1

BS EN (IEC) 61000-4-7

BS EN (IEC) 61000-4-30

BS EN (IEC) 61642

BS EN 50160

IEC 61000-2-2 [5] and IEC 61000-2-12 [6]

This European Standard specifies the limits for the voltage quality at a network used for the distribution of electricity to public distribution networks and individual networks.

of the voltage quality of the electricity supplied to the limits or whole of the network experienced by

Odd harmonics non-multiple of 3		Odd harmonics multiple of 3		Even harmonics	
Harmonic order h	Harmonic voltage %	Harmonic order h	Harmonic voltage %	Harmonic order h	Harmonic voltage %
5	6	3	5	2	2
7	5	9	1,5	4	1
11	3,5	15	0,4	6	0,5
13	3	21	0,3	8	0,5
$17 \leq h \leq 49$	$2,27 \cdot \frac{17}{h} - 0,27$	$21 < h \leq 45$	0,2	$10 \leq h \leq 50$	$0,25 \cdot \frac{10}{h} + 0,25$

NOTE The compatibility level for the total harmonic distortion is THD = 8 %.

Order h
Not multiples of 3

Order h	Relative voltage
5	6,0 %
7	5,0 %
11	3,5 %
13	3,0 %
17	2,0 %
19	1,5 %
23	1,5 %
25	1,5 %

NOTE No values are given for harmonics of order higher than 25, as they are usually small, but largely unpredictable due to resonance effects.

Even harmonics

Order h	Relative voltage (U_n)	Order h	Relative voltage (U_n)	Order h	Relative voltage (U_n)
5	6,0 %	3	5,0 % ^a	2	2,0 %
7	5,0 %	9	1,5 %	4	1,0 %
11	3,5 %	15	0,5 %	6 ... 24	0,5 %
13	3,0 %	21	0,5 %		
17	2,0 %				
19	1,5 %				
23	1,5 %				
25	1,5 %				

^a Depending on the network design the value for the third harmonic order can be substantially lower.

NOTE No values are given for harmonics of order higher than 25, as they are usually small, but largely unpredictable due to resonance effects.

Which one applies to UK?

Grid Code CC 6.1.5:

- The **Electromagnetic Compatibility Levels** for harmonic distortion on the **Onshore Transmission System** from all sources under both **Planned Outage** and fault outage conditions, (unless abnormal conditions prevail) shall comply with the levels shown in the tables of Appendix A of **Engineering Recommendation G5/4-1**. The **Electromagnetic Compatibility Levels** for harmonic distortion on an **Offshore Transmission System** will be defined in relevant **Bilateral Agreements**.
- **Engineering Recommendation G5/4-1** contains planning criteria which **NGET** will apply to the connection of non-linear **Load** to the **National Electricity Transmission System**, which may result in harmonic emission limits being specified for these **Loads** in the relevant **Bilateral Agreement**. The application of the planning criteria will take into account the position of existing and prospective **Users' Plant** and **Apparatus** in relation to harmonic emissions. **Users** must ensure that connection of distorting loads to their **User Systems** do not cause any harmonic emission limits specified in the **Bilateral Agreement**, or where no such limits are specified, the relevant planning levels specified in **Engineering Recommendation G5/4** to be exceeded.

Distribution Code DPC4.2.3.2(b)

- The harmonic content of a load shall comply with the limits set out in Distribution Glossary and Definitions Annex 1, Item 1 **Engineering Recommendation G5/4-1**, "Planning levels for harmonic voltage distortion and the connection of non-linear equipment to transmission and distribution systems in the United Kingdom."

How this is approached in G5/4-1?

- **Apply ER G5/4-1 Stage 1-2-3 assessment for all new connections with a possibility to introduce new harmonic pollution or likely to modify existing distortion on the system.**
- **Introduce harmonic specification in the form of allowable distortion to Bilateral Connection Agreements so that ER G5/4-1 Planning Levels are not exceeded.**
- **Monitor those limits post commissioning stage to check compliance.**

Stage 3 Assessment

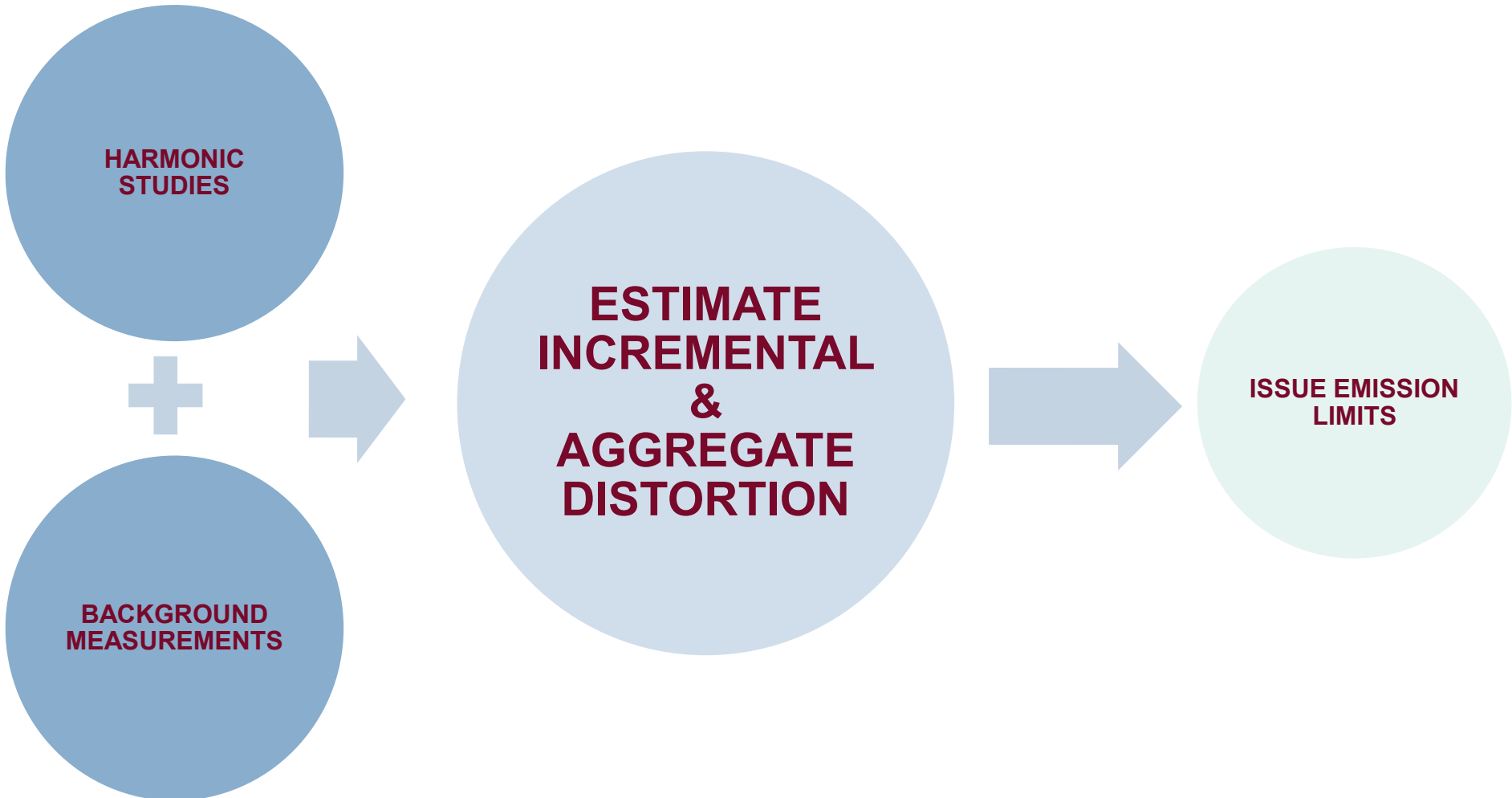

Incremental, Background & Aggregate Distortion

INCREMENTAL



Distortion caused by the injected currents only. Interaction between injected current and the system impedance which includes customer's impedance.

BACKGROUND



Distortion that exist on the system as it stands.

AGGREGATE



Combined distortion due to injection only and the background as modified by customer's installation.

Harmonic Studies

- **If possible entire network is modelled**
 - Detailed harmonic impedance model of the network
- **Detailed model of other networks close to connection**
 - Transmission vs distribution
 - Check for resonance conditions
 - Consider voltage distortion at the connection point *and* other nodes (not necessarily owned by the network owner/operator)
- **Consider various demand levels and typical planned outages**
- **Remaining parts represented by simpler lumped models**

Background Distortion Measurements

- **Minimum period of 7 days (no bank holidays!)**
- **95th percentile assumed for background**
- **Preferably no outages**
- **Choose a few representative sites**
- **Not possible at some locations (no suitable transducer)**
- **Access can be a problem (3rd party sites)**

Decision on Harmonic Emission Limits

If planning levels are not reached anywhere, then declared emission levels are acceptable and become incremental limits.

Background modification?

First node to reach planning level is the limiting node.

Set limits such that planning levels are not exceeded?

Easier Said Than Done!

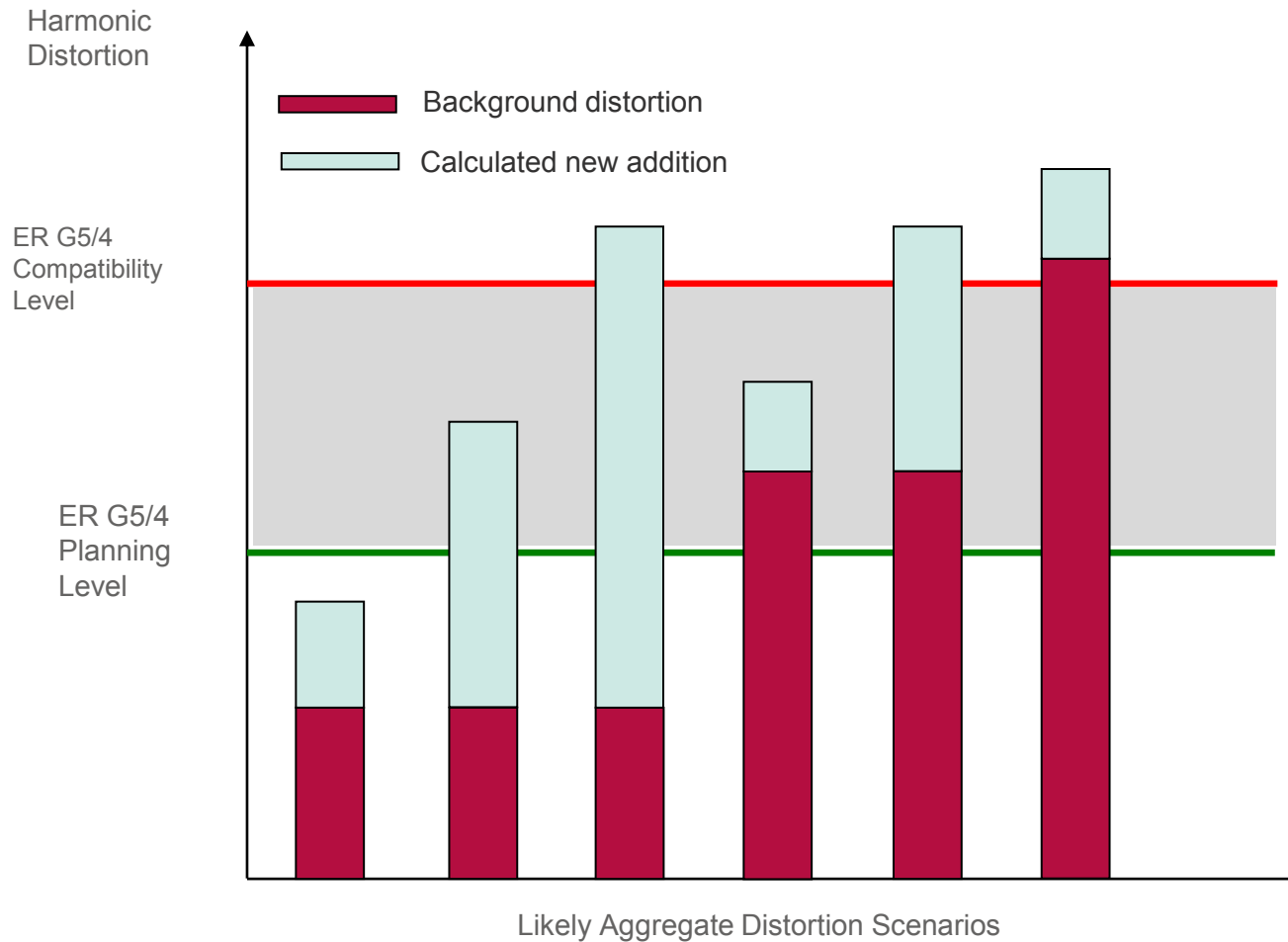

Example Emission Limits Specification

Harmonic voltage limits as % of fundamental

h	V_i	V_a	V_b	h	V_i	V_a	V_b
2	0.16	0.16	0.055	27	0.1	0.1	0.050
3	1.72	2.0	0.159	28	0.1	0.2	0.050
4	0.8	0.8	0.056	29	0.1	0.13	0.050
5	0.6	2	0.408	30	0.1	0.1	0.050
6	0.47	0.5	0.064	31	0.1	0.11	0.050
7	1.75	2.0	0.326	32	0.1	0.1	0.050
8	0.27	0.28	0.050	33	0.1	0.18	0.050
9	0.10	0.1	0.050	34	0.1	0.18	0.050
10	0.19	0.31	0.050	35	0.1	0.1	0.050
11	0.10	0.10	0.050	36	0.1	0.1	0.050
12	0.10	0.10	0.050	37	0.1	0.1	0.050
13	0.10	0.10	0.050	38	0.1	0.1	0.050
14	0.10	0.10	0.050	39	0.1	0.1	0.050
15	0.26	0.27	0.050	40	0.1	0.1	0.050
16	0.16	0.2	0.050	41	0.1	0.1	0.050
17	0.38	0.49	0.050	42	0.1	0.2	0.050
18	0.1	0.2	0.050	43	0.1	0.491	0.050
19	0.1	0.1	0.050	44	0.1	0.2	0.050
20	0.1	0.1	0.050	45	0.12	0.2	0.078
21	0.1	0.1	0.050	46	0.1	0.2	0.050
22	0.1	0.1	0.050	47	0.1	0.27	0.125
23	0.1	0.22	0.050	48	0.1	0.12	0.050
24	0.1	0.1	0.050	49	0.1	0.1	0.050
25	0.1	0.1	0.050	50	0.1	0.1	0.050
26	0.1	0.1	0.050				

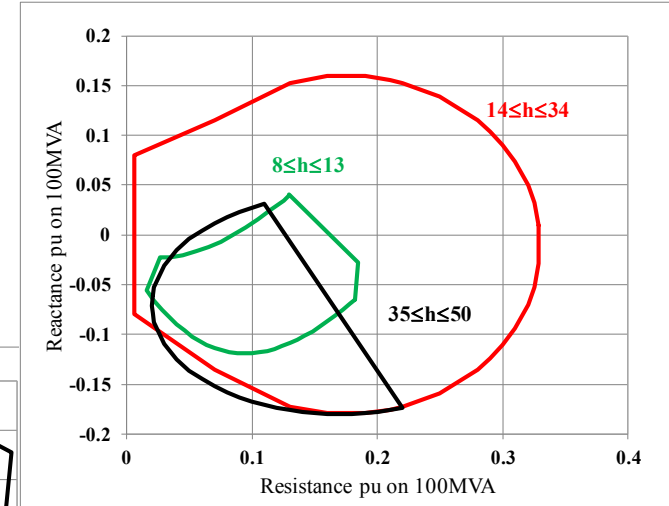
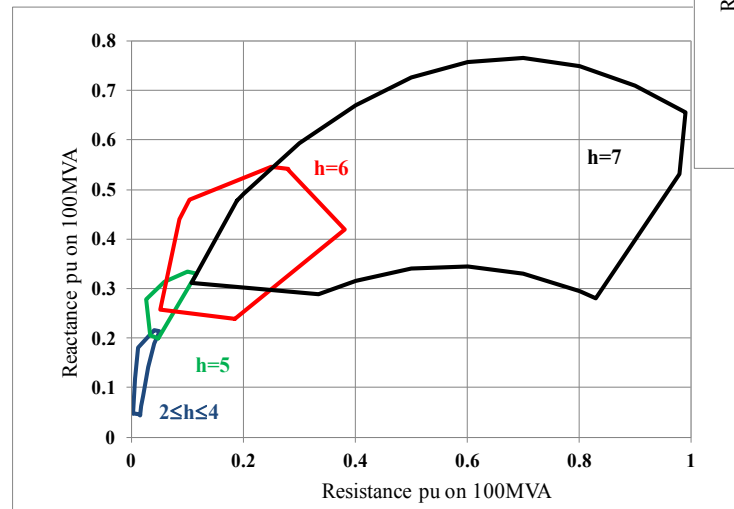

Table and Figures courtesy of Z Emin, F Fernandez, M Poeller and G E Williamson "Harmonic Distortion Specification and Compliance of an Offshore Wind Generation" Paper 0054, IET ACDC2012 Conference

What is happening beyond 50th ?

- Numerous electromagnetic interference cases have been collected in the frequency range 2 to 150kHz (mainly by CISPR).
- Questionnaire was circulated in January 2011 for the maintenance of IEC 61000-2-2 and IEC 61000-2-12 as a priority, in order to close the gap in the frequency range 2-150 kHz. Replies of National Committees were favourable and hence the maintenance of these two standards have started mainly dealing with the
 - the definition of new compatibility levels between 2 and 150kHz,
 - inclusion of information on mains signalling between 3 and 150kHz,
 - the revision of existing compatibility levels, if necessary.

BS EN 61000-2-2
(IEC)

Electromagnetic compatibility (EMC). Environment. Compatibility levels for low-frequency conducted disturbances and signalling in public low-voltage power supply systems

BS EN 61000-2-12
(IEC)

Electromagnetic compatibility (EMC). Environment. Compatibility levels for low-frequency conducted disturbances and signalling in public medium-voltage power supply systems

Other IEC Documents

- Some IEC documentation within the remit of SC77A WG8 that was assessed to be relevant with respect to development of smart grids are:

BS EN 61000-2-2 (IEC)	Electromagnetic compatibility (EMC). Environment. Compatibility levels for low-frequency conducted disturbances and signalling in public low-voltage power supply systems
BS EN 61000-2-4 (IEC)	Electromagnetic compatibility (EMC). Environment. Compatibility levels in industrial plants for low-frequency conducted disturbances
BS EN 61000-2-12 (IEC)	Electromagnetic compatibility (EMC). Environment. Compatibility levels for low-frequency conducted disturbances and signalling in public medium-voltage power supply systems

compatibility levels needed to fill the gap from 2 to 150kHz

IEC TR 61000-3-6	Electromagnetic compatibility (EMC). Limits. Assessment of emission limits for the connection of distorting installations to MV, HV and EHV power systems
IEC TR 61000-3-7	Electromagnetic compatibility (EMC). Limits. Assessment of emission limits for the connection of fluctuating installations to MV, HV and EHV power systems
IEC TR 61000-3-13	Electromagnetic compatibility (EMC). Limits. Assessment of emission limits for the connection of unbalanced installations to MV, HV and EHV power systems
IEC TR 61000-3-14	Electromagnetic compatibility (EMC) - Assessment of emission limits for harmonics, interharmonics, voltage fluctuations and unbalance for the connection of disturbing installations to LV power systems

need to evolve to take into account the influence of dispersed generation and new operating modes and to fill the gap from 2 to 150kHz

TSO Policy & Proposed Methodology for limit calculation

Mark Norton
Technology and Innovation



Agenda



High level Facts

Policy breakdown – Planning levels

Policy Breakdown – Planning Margin

Policy breakdown – Allocated distortion limits

Policy Breakdown – Background levels

Policy Breakdown – Method of calculating limits

Summary



Agenda



High level Facts

Policy breakdown – Planning Levels

Policy Breakdown – Planning Margin

Policy breakdown – Allocated distortion limits

Policy Breakdown – Background levels

Policy Breakdown – Method of calculating limits

Summary



TSO Policy



Facts:

- Based on IEC/TR 61000-3-6 recommended methodology for transmission in Appendix D
- Accounts for both local and remote harmonic sources
- Maintains a margin between planning levels and predicted harmonic distortion
- Applies to users and network reinforcement
- Forward facing



Study Process

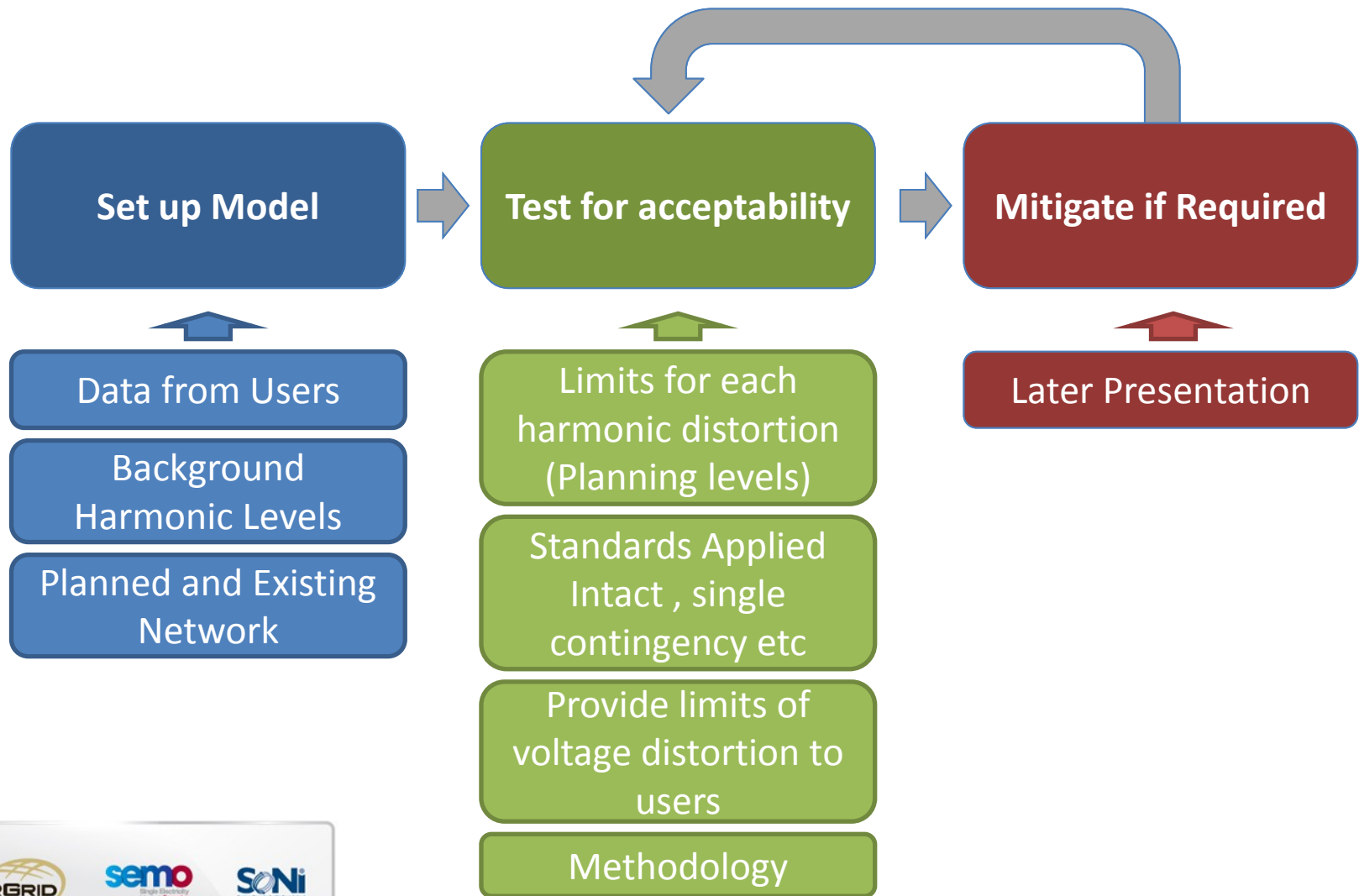

Study Process

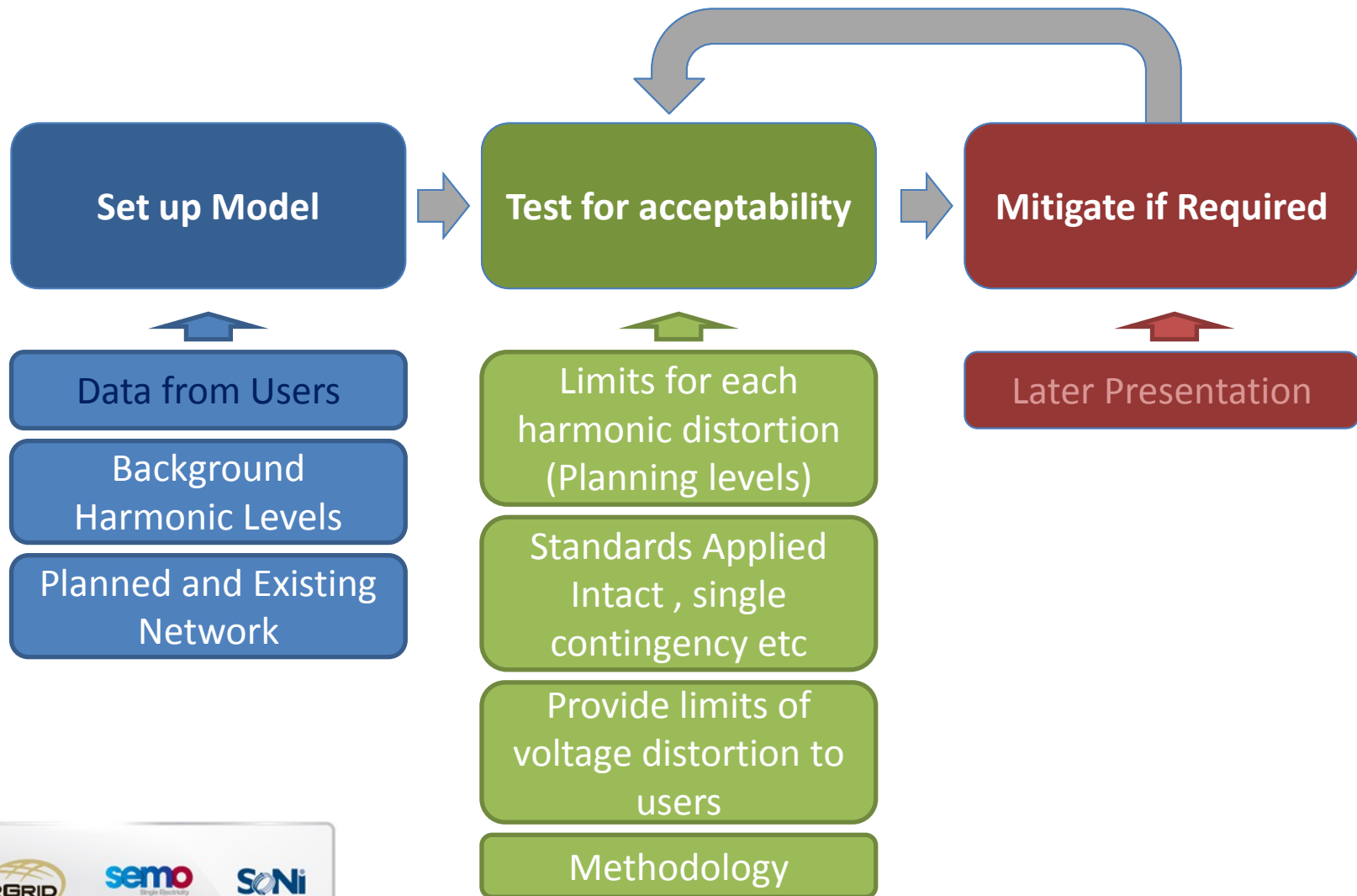

Agenda



High level Facts

Policy breakdown – Planning levels

Policy Breakdown – Planning Margin

Policy breakdown – Allocated distortion limits

Policy Breakdown – Method of calculating limits

Policy Breakdown – Background levels

Summary



TSO Planning levels



Policy:

- IEC/TR61000-3-6 planning levels in Table 2 will be maintained
- Planning levels apply to intact and single contingency cases (N-1)
- Engineering Recommendation G5/4 used by NIE

Rationale:

- IEC International best practice
- Consistent with TPC other power quality requirements
- Duration and predictability of single contingency
- N-1 recommended in the IEC



Agenda



High level Facts

Policy breakdown – Planning levels

Policy Breakdown – Planning Margin

Policy breakdown – Allocated distortion limits

Policy Breakdown – Background levels

Policy Breakdown – Method of calculating limits

Summary



TSO Planning Margin



Policy:

- Maintain 25% margin from the available increase from the background levels to the Planning Levels

Rationale:

- System strength reduction will amplify harmonic distortion
- Reasonable margin level for future balanced against cost of margin retention



Example Theoretical

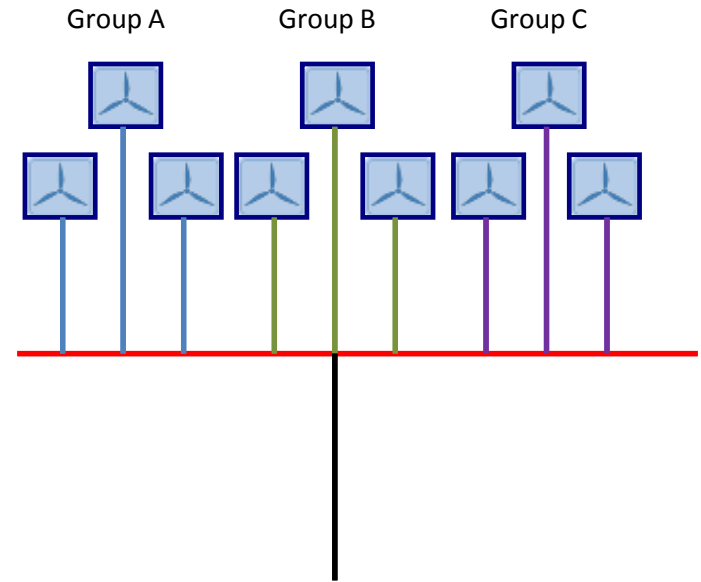
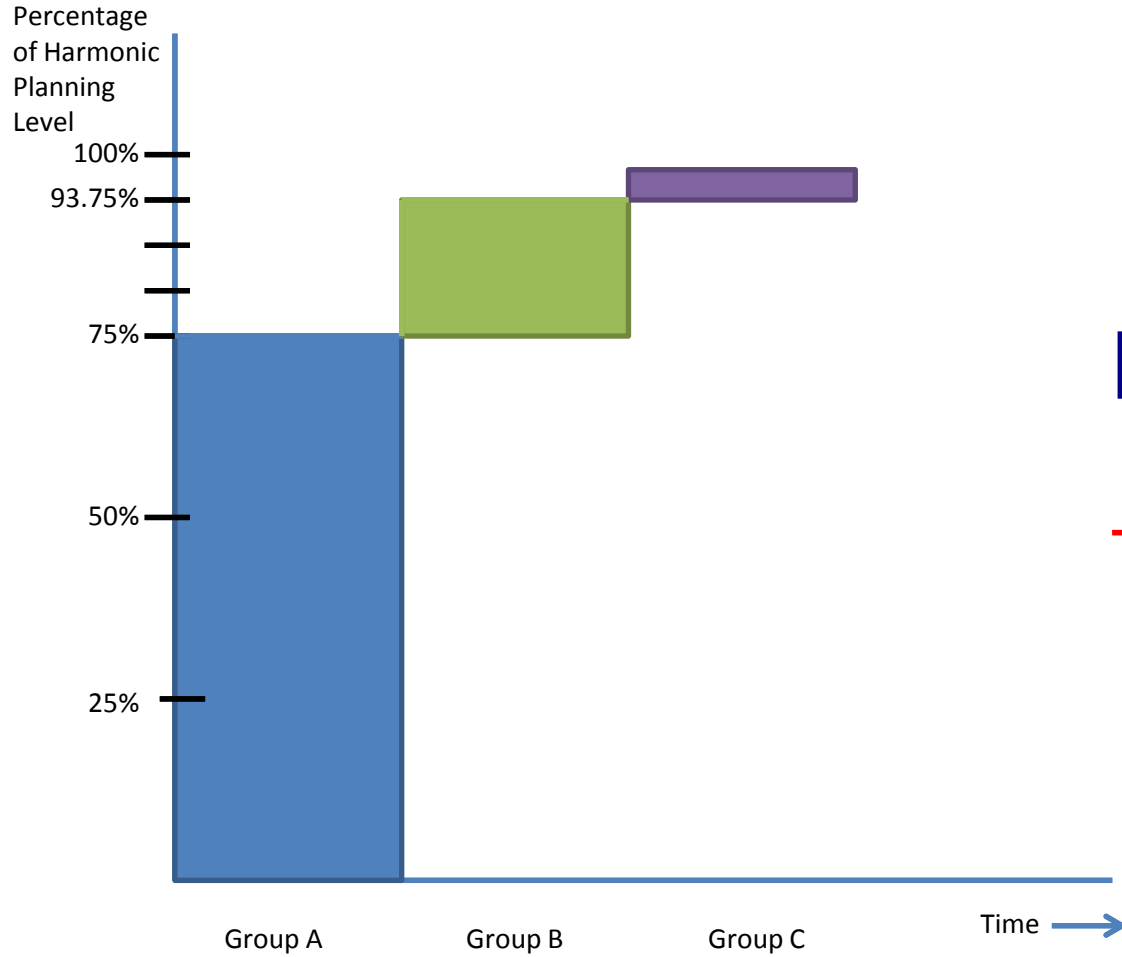

Example Practical

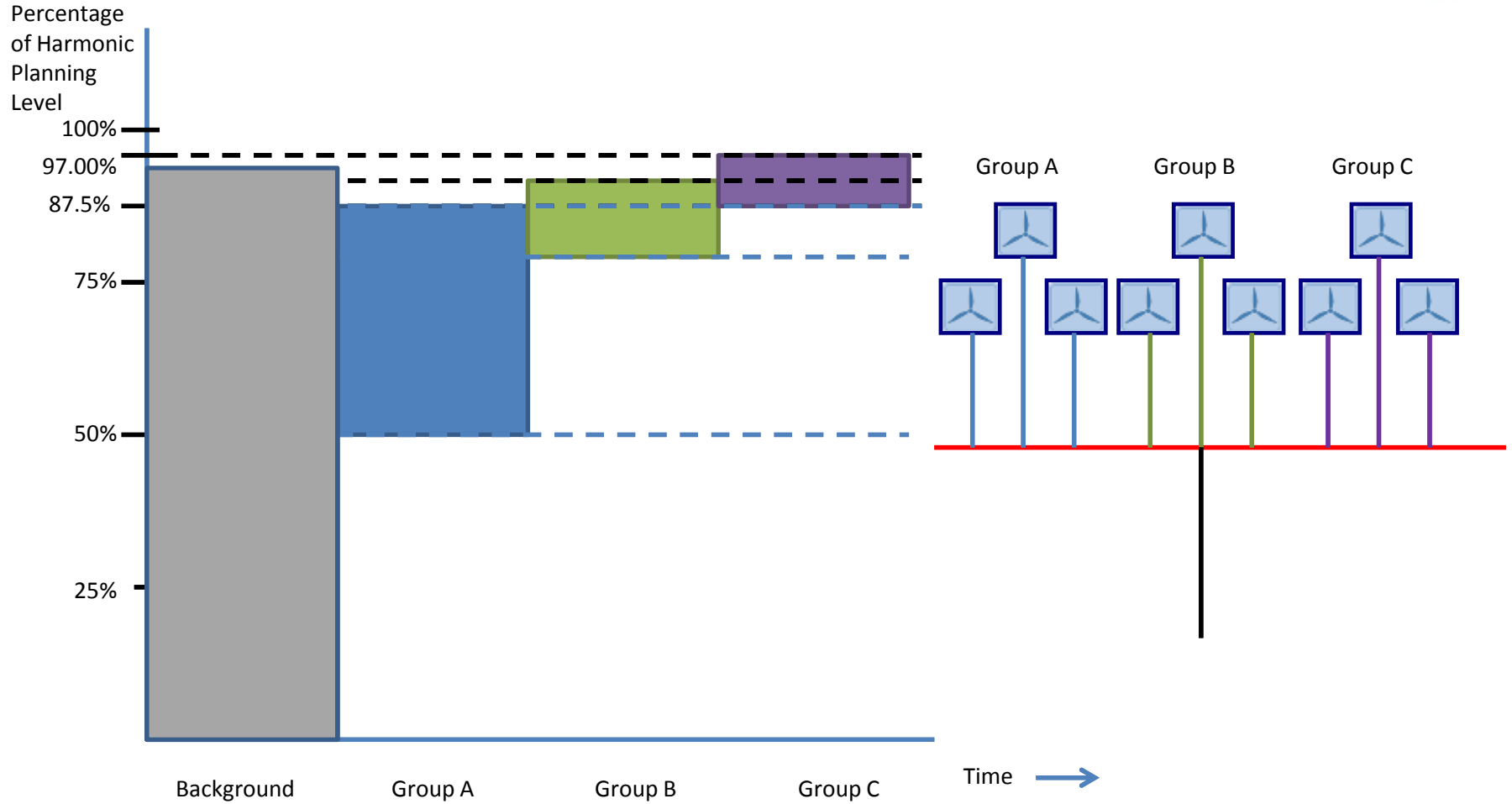

Agenda



High level Facts

Policy breakdown – Planning levels

Policy Breakdown – Planning Margin

Policy breakdown – Allocated distortion limits

Policy Breakdown – Background levels

Policy Breakdown – Method of calculating limits

Summary



TSO Allocated Distortion Limits



Policy:

- Limits referenced to connection point
- MW pro-rated to connecting parties at each node
- Background readings incorporated (next section)
- Calculated for existing and planned network
- Calculated for intact and single contingency

Rationale:

- IEC International best practice
- N-1 and future proofed networks recommended in the IEC
- Connection point is current contractual point and either side is within User and TSO control
- Connection point will be reflective of future configuration
- MW pro-rata is a fair average portioning of available distortion capacity (User defines their own internal equipment)



Agenda



High level Facts

Policy breakdown – Planning levels

Policy Breakdown – Planning Margin

Policy breakdown – Allocated distortion limits

Policy Breakdown – Background levels

Policy Breakdown – Method of calculating limits

Summary



TSO Background levels



Policy:

- Utilise background readings to tune model
- Use approach in IEC 61000-4-30 and associated 61000-4-7
- 10 minute readings over 1 Week minimum
- Readings from each busbar user or reinforcement is connecting to
- New nodes reading taken electrically as close as possible

Rationale:

- IEC International best practice
- Maximum single point harmonic level to onerous
- Annual time period impact on harmonic levels
- 1 week recommended as minimum in IEC
- Actual rather than modelled harmonics in model
- Best method of tuning for new nodes



Agenda



High level Facts

Policy breakdown – Planning levels

Policy Breakdown – Planning Margin

Policy breakdown – Allocated distortion limits

Policy Breakdown – Background levels

Policy Breakdown – Method of calculating limits

Summary



TSO Method



Policy:

- Calculation method based on IEC Appendix D method
- Suitable for Transmission meshed systems
- Utilises standard method tools to ensure non-discriminatory process

Rationale:

- IEC International best practice
- Accounts for other generation impact on buses in area



Example

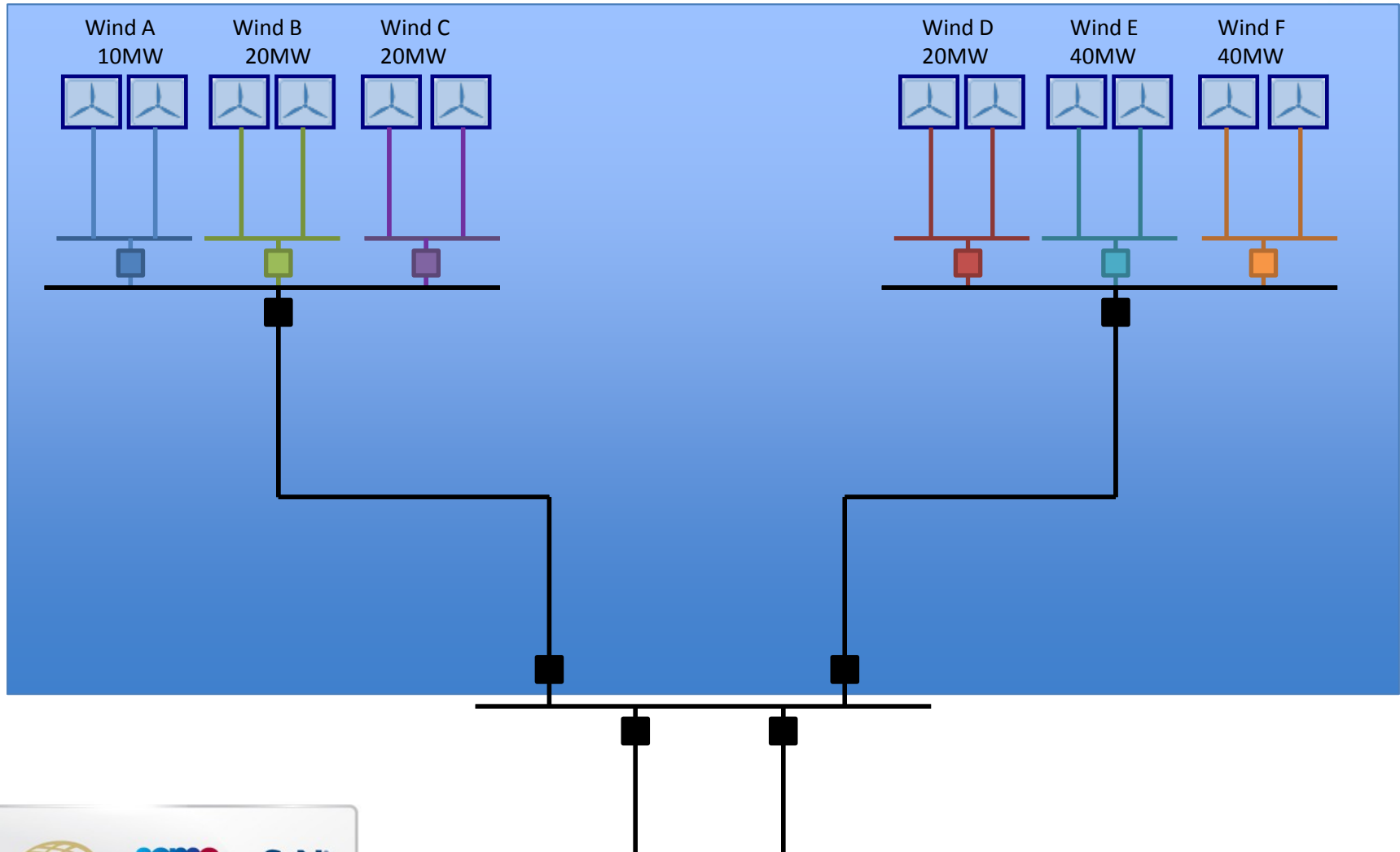

Example – Step 1 tune network



Inject currents for
background
Harmonics

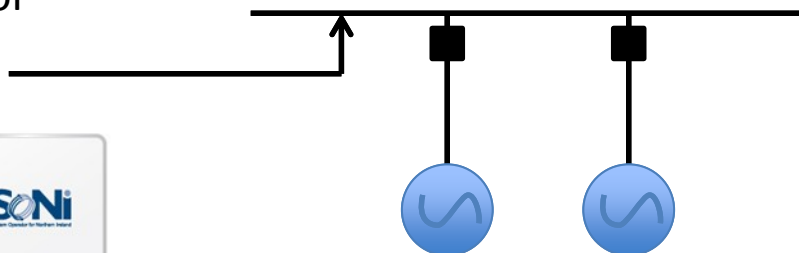

Example – Step 2 Add in new transmission network

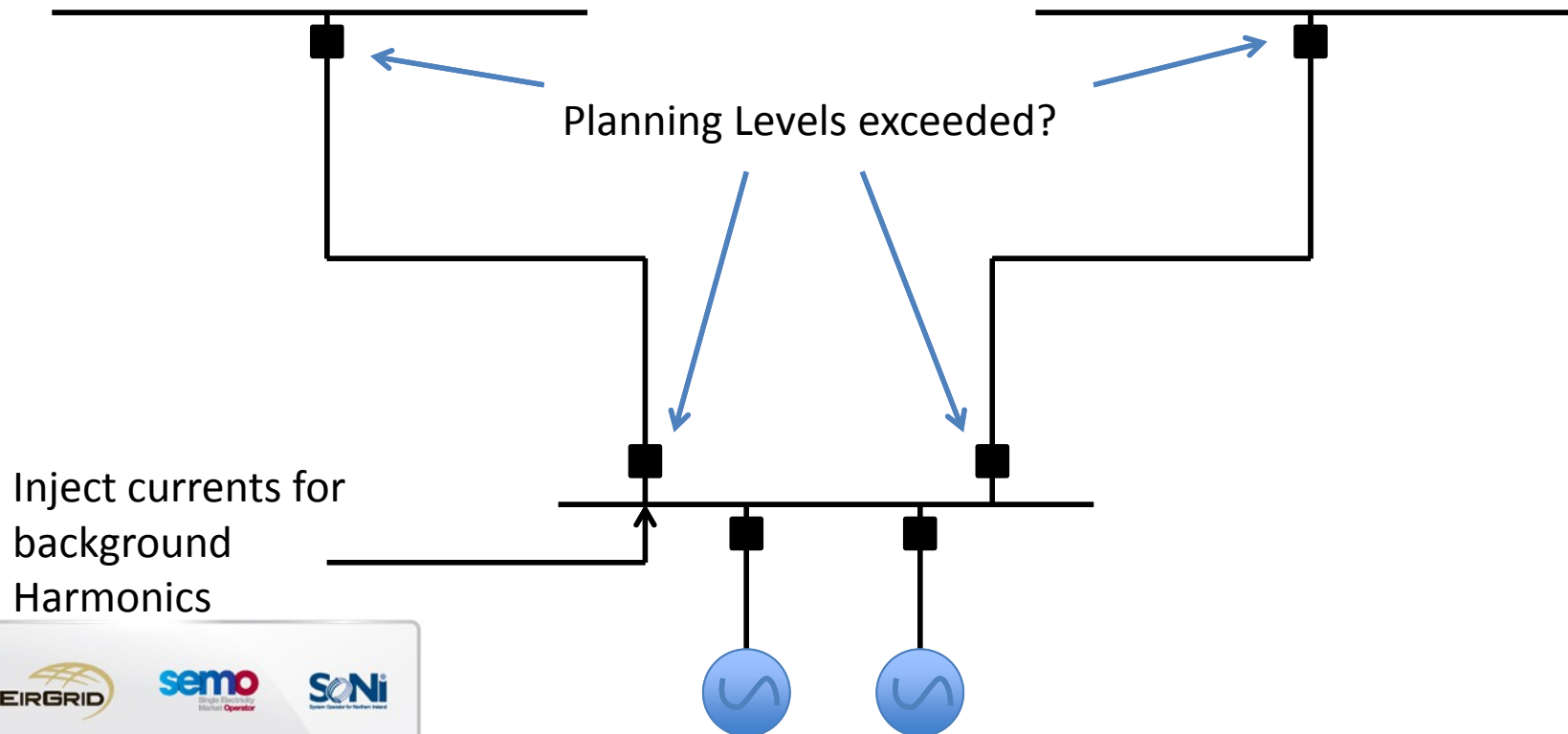

Inject currents for background Harmonics



Example – Step 2 Add in new transmission network

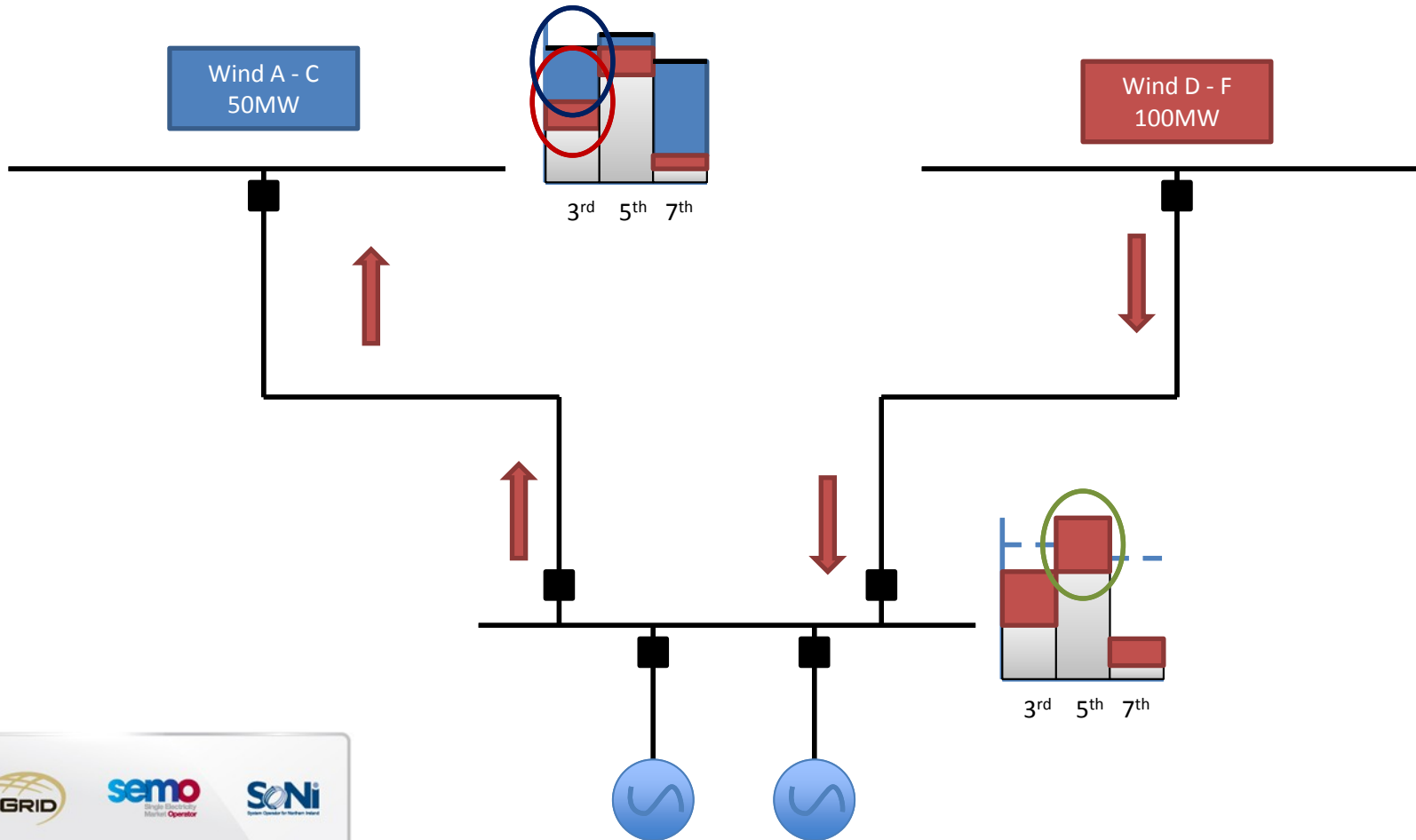

Example – Step 2 Add in new transmission network

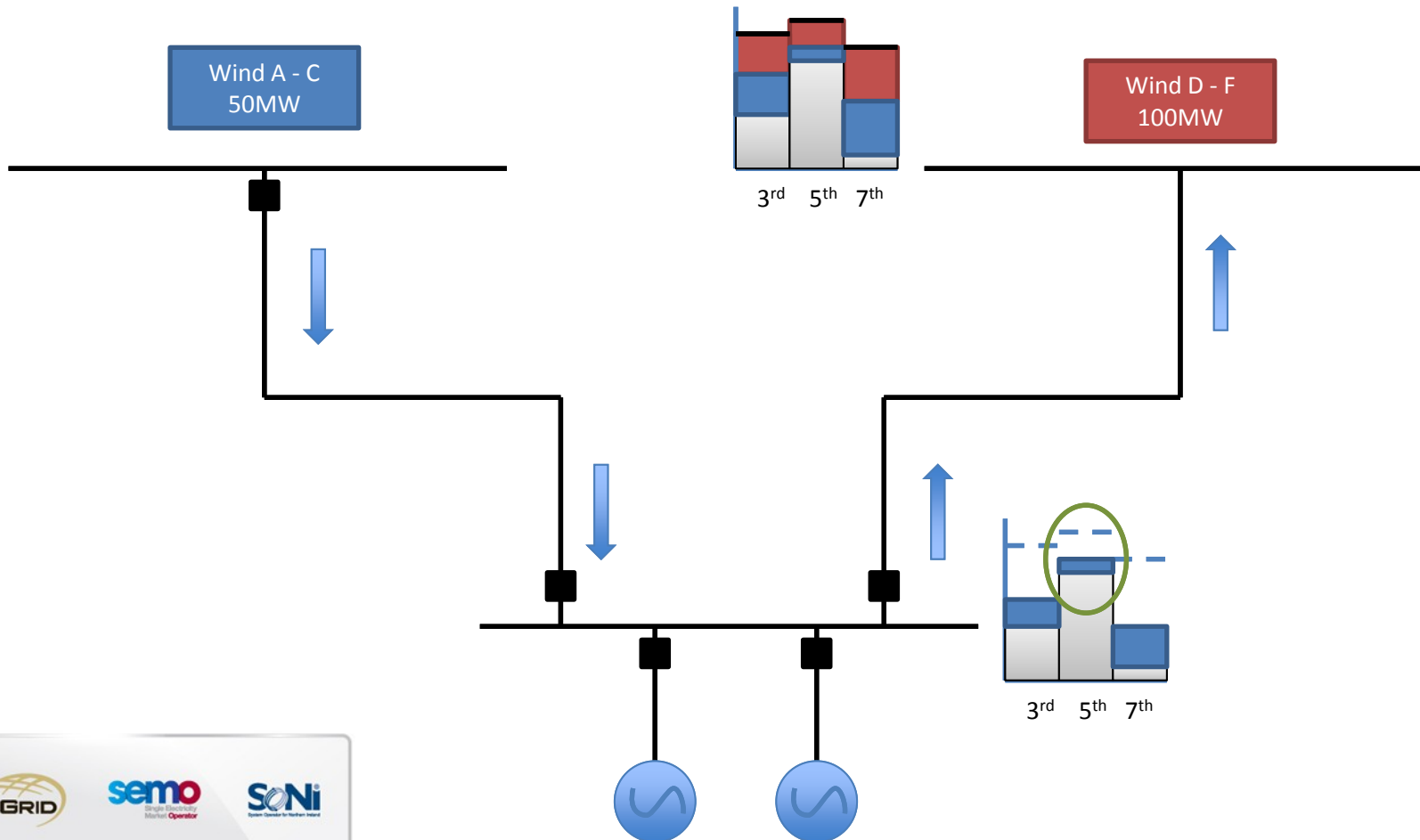

Example – Step 2 Add in new transmission network

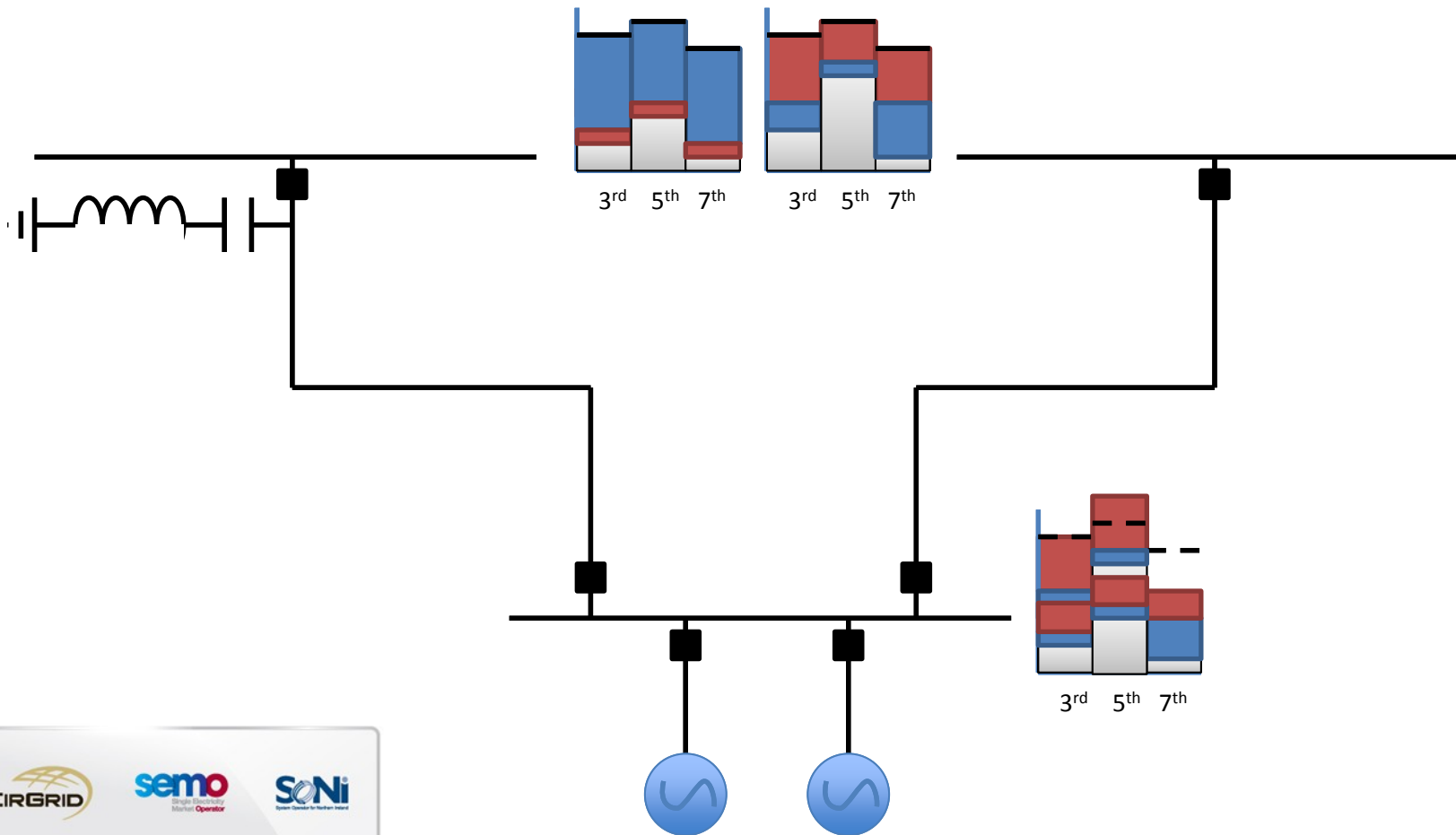

Example – Step 3 Calculate wind farms distortion limits

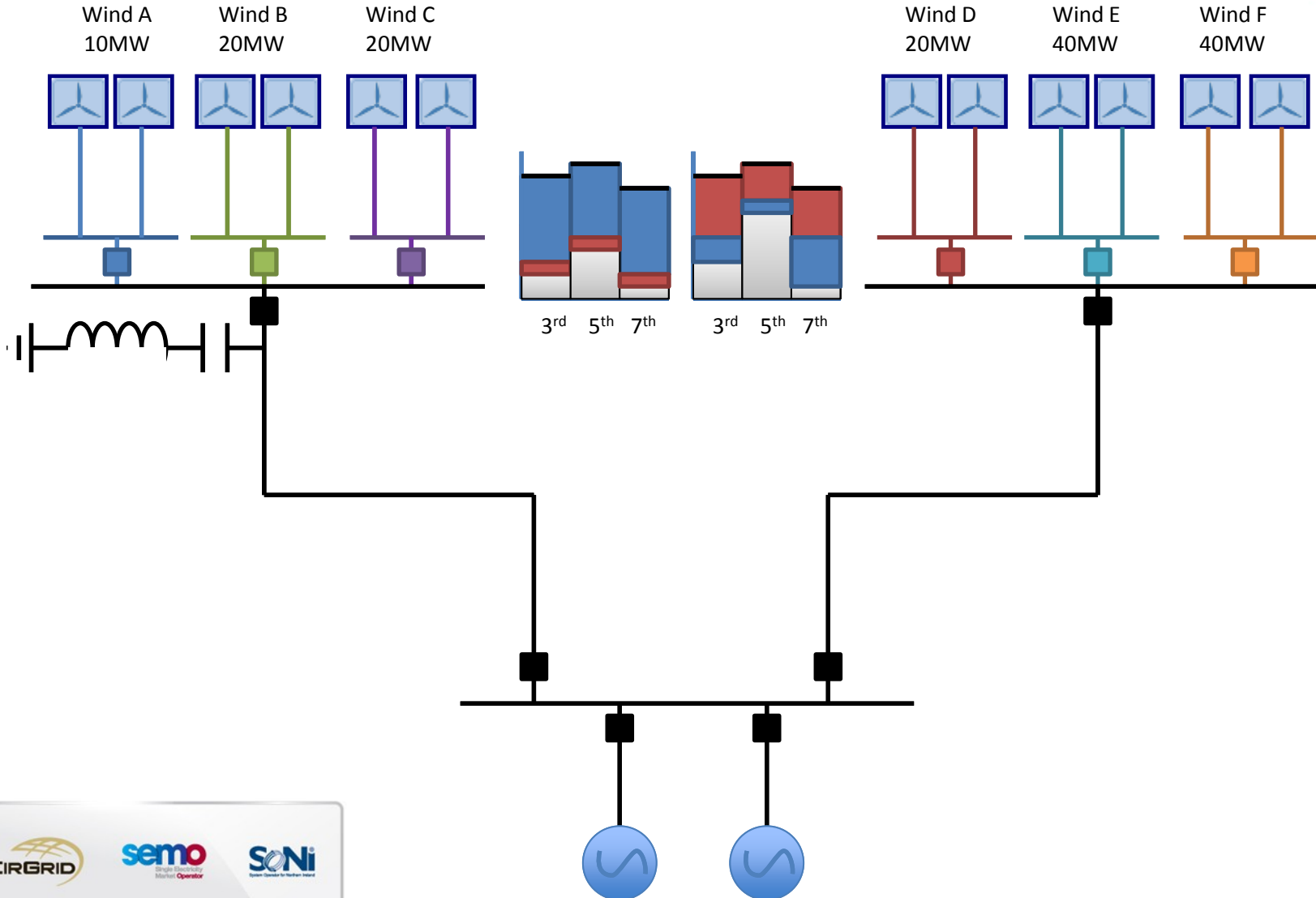

Example – Step 3 Calculate wind farms distortion limits

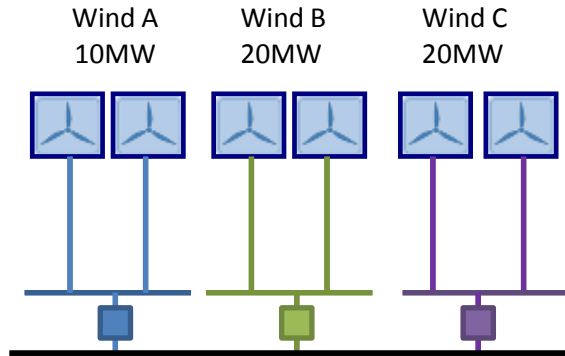

- All intact and single contingency conditions
- Smallest allowable increase in voltage distortion used to calculate limits for Users
- Probability factor (summation exponent) relaxes limits
- Available increase in distortion given proportionately to Users

If 3rd harmonic distortion capacity increase is 1.0% then:

$$\begin{aligned} \text{Wind A} &= \text{probability factor} * \text{Windfarm size/station total wind} * \text{design level} * \text{distortion limit} \\ &= 1.4\sqrt{10\text{MW}/50\text{MW}} * 1.0\% \\ &= \mathbf{0.32\%} \end{aligned}$$

$$\begin{aligned} \text{Wind B or C} &= \text{probability factor} * \text{Windfarm size/station total wind} * \text{design level} * \text{distortion limit} \\ &= 1.4\sqrt{20\text{MW}/50\text{MW}} * 1.0\% \\ &= \mathbf{0.52\%} \end{aligned}$$

Example – Step 3 Calculate wind farms distortion limits

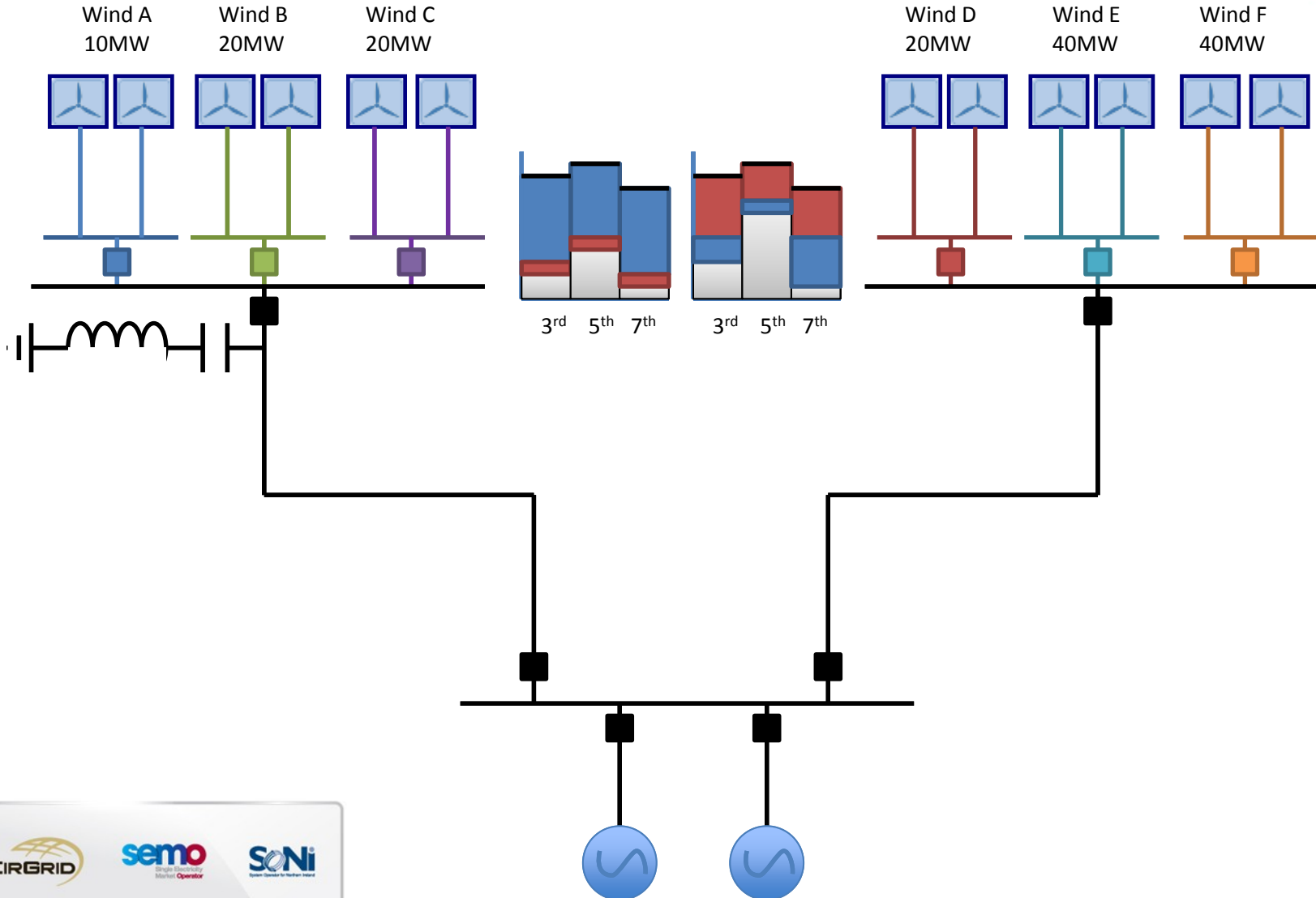

Example – Step 3 Calculate wind farms distortion limits



If 3rd harmonic distortion capacity increase is 0.5% then:

Wind D = probability factor * Windfarm size/station total wind design level * distortion limit

$$= 1.4\sqrt{(20\text{MW}/100\text{MW})} * 0.5\%$$
$$= \mathbf{0.16\%}$$

Wind E or F = probability factor * Windfarm size/station total wind design level * distortion limit

$$= 1.4\sqrt{(40\text{MW}/100\text{MW})} * 0.5\%$$
$$= \mathbf{0.26\%}$$

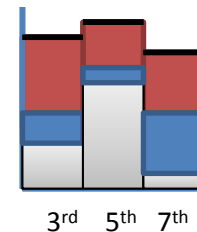
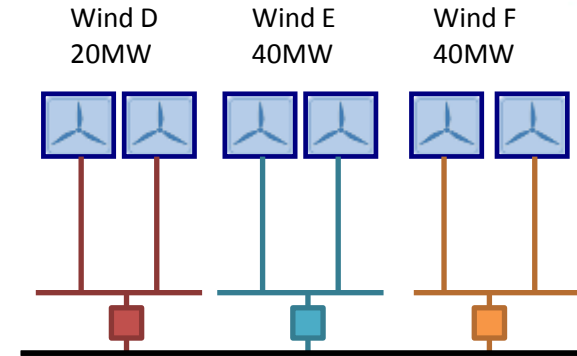

Agenda



High level Facts

Policy breakdown – Planning levels

Policy Breakdown – Planning Margin

Policy breakdown – Allocated distortion limits

Policy Breakdown – Background levels

Policy Breakdown – Method of calculating limits

Summary



Summary



- Based on International Best Practice
- Consistent with equipment manufacturer
- Proportionate and equitable
- Transparent
- Mitigates short and long term issues
- Policy requirements defined and will be provided to Users







NETWORKS

DSO Policy & Proposed Methodology for Limit Calculations

Ivan Codd
Renewable Planning Manager,
Asset Management, ESB Networks

21st November 2013

- The DSO is defined in the Grid Code as a User of the transmission system at each TSO/DSO interface – ie generally each 110kV node (220kV nodes in Greater Dublin)
- Harmonic voltage distortion limits will be supplied by Eirgrid for each TSO/DSO interface point
- DSO is required to ensure the harmonic distortion at all customer connection points is within limits specified in EN 50160
- IEC/TR 61000-3-6 provides guidance to SOs on how to determine emission limits for individual customers

- DSO study will determine harmonic emission limits at each generator connection point such that:
 - Harmonic distortion limits specified at TSO/DSO interface are not exceeded

and

- Harmonic levels within distribution system do not exceed relevant planning levels
 - Distribution planning levels based on IEC/TR 61000-3-6

STUDIES TO BE CARRIED OUT

- ESB Networks will carry out a review of all generation customers yet to connect to assess applicable harmonic limits
- Connections due to energise within the next 24 months will be treated on a case by case basis
- Limits will be provided 18 months in advance of connection.
- Harmonic implications of any modifications to connection offers will be taken into account during re-assessment

HARMONICS AT DIFFERENT VOLTAGES

Harmonic emission limits more stringent at the higher voltage levels



110kV



38kV



10kV /
20kV

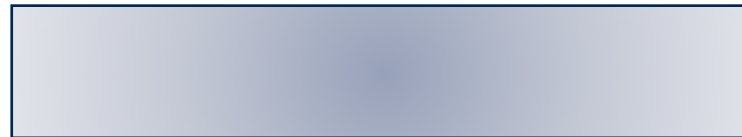

LV



Domestic/
Industrial
Customers

ODD HARMONICS, NON MULTIPLES OF 3

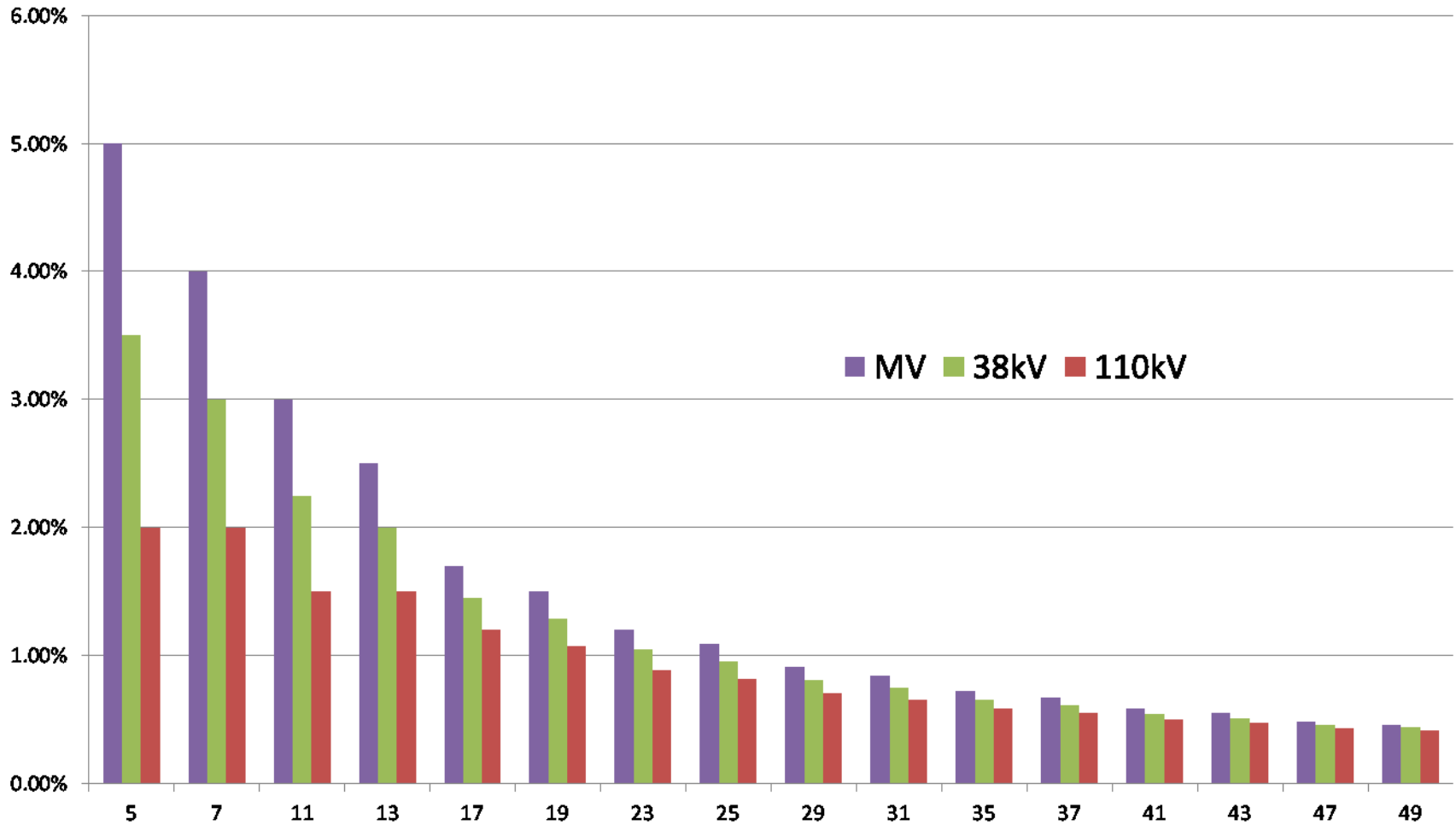

ODD HARMONICS, MULTIPLES OF 3

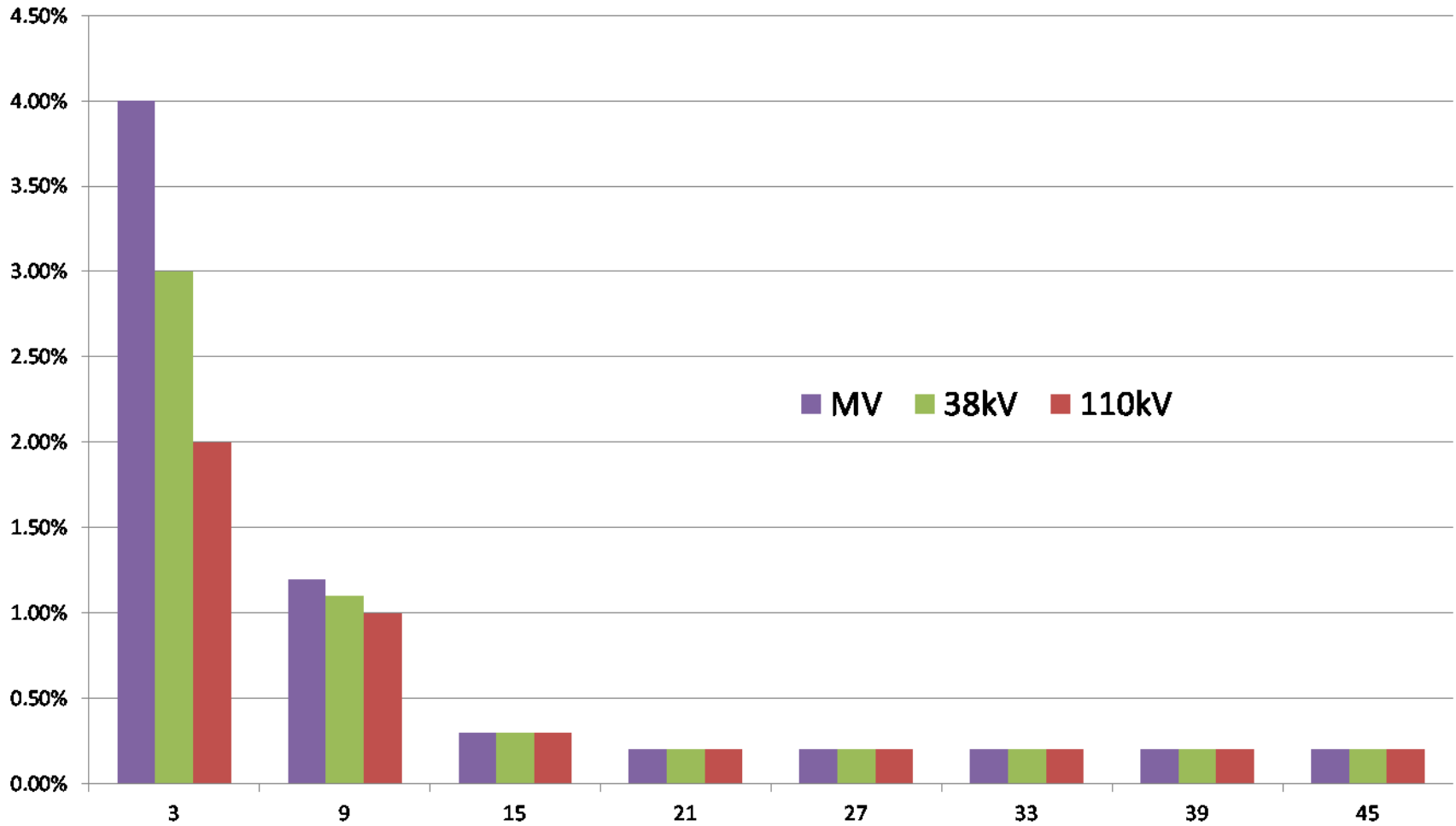

EVEN HARMONICS

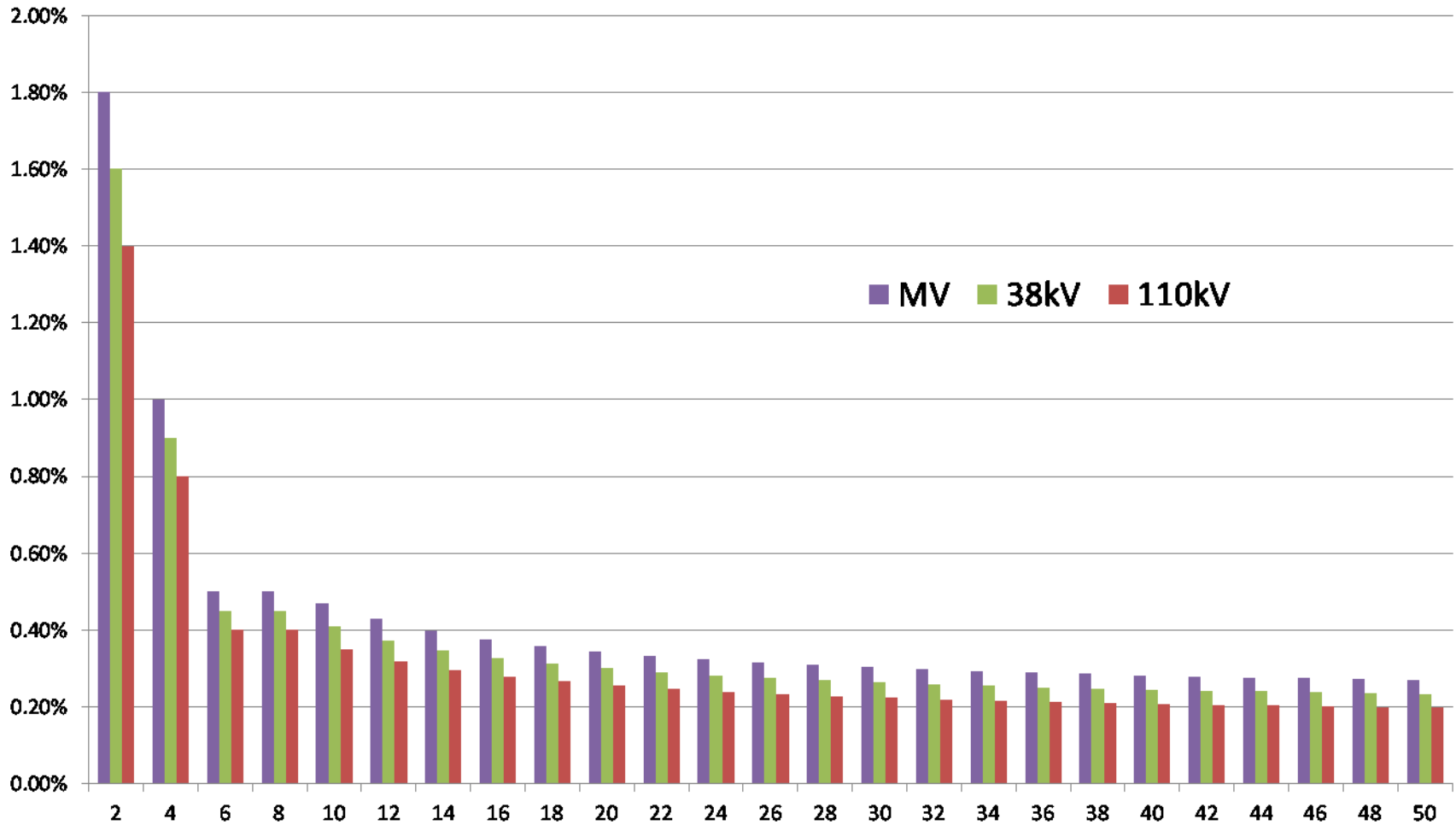

HARMONIC PLANNING LEVELS APPLICABLE

For MV (10kV and 20kV) network, the MV indicative planning levels in IEC/TR 61000-3-6 will be applied to the network studied

Harmonic Order	Harmonic Voltage	Harmonic Order	Harmonic Voltage	Harmonic Order	Harmonic Voltage
h	%	h	%	h	%
5	5	3	4	2	1.8
7	4	9	1.2	4	1
11	3	15	0.3	6	0.5
13	2.5	21	0.2	8	0.5
$17 \leq h \leq 49$	$1.9 \times 17/h - 0.2$	$21 < h \leq 45$	0.2	$10 \leq h \leq 50$	$0.25 \times 10/h + 0.22$

HARMONIC PLANNING LEVELS APPLICABLE

For 38kV network, intermediate values between the MV and HV-EHV indicative planning levels in IEC/TR 61000-3-6 will be applied to the network studied.

Harmonic Order	Harmonic Voltage	Harmonic Order	Harmonic Voltage	Harmonic Order	Harmonic Voltage
h	%	h	%	h	%
5	3.5	3	3	2	1.6
7	3	9	1.2	4	0.9
11	2.75	15	0.3	6	0.45
13	2	21	0.2	8	0.45

All other harmonic orders ≤ 50 : (MV Planning Level + HV-EHV Planning Level) / 2

HARMONIC PLANNING LEVELS APPLICABLE

For 110kV network, the indicative HV-EHV planning levels in IEC/TR 61000-3-6 will be applied to the network studied.

Harmonic Order	Harmonic Voltage	Harmonic Order	Harmonic Voltage	Harmonic Order	Harmonic Voltage
h	%	h	%	h	%
5	2	3	2	2	1.4
7	2	9	1	4	0.8
11	1.5	15	0.3	6	0.4
13	1.5	21	0.2	8	0.4
17≤h≤49	1.2x17/h	21<h≤45	0.2	10≤h≤50	0.19x10/h +0.16

The maximum additional harmonic emissions on to the Distribution network connected to a specific TSO/DSO node will be determined by either

- The specific limits imposed by Eirgrid at that node

or

- Distribution system factors
 - o Existing levels of harmonics at that node
 - o Planning Level for the relevant Distribution voltage(s)
 - with appropriate reserve for future connections
 - o Potential for resonance effects on the specific Distribution system
 - UG cables introduce potential for resonance at lower harmonic orders
- The maximum additional emissions will be apportioned to new generators on the basis of MEC

Example network configuration:

- 2 x 63MVA 110/38kV station
- One pre-Gate 3 38kV windfarm
- Load at 38kV

Two Gate 3 windfarms to be assessed:

- 15MW connection at 38kV to the 110kV station
- 5MW connection at 20kV to a 38kV station

ALLOCATION OF HARMONIC LIMITS

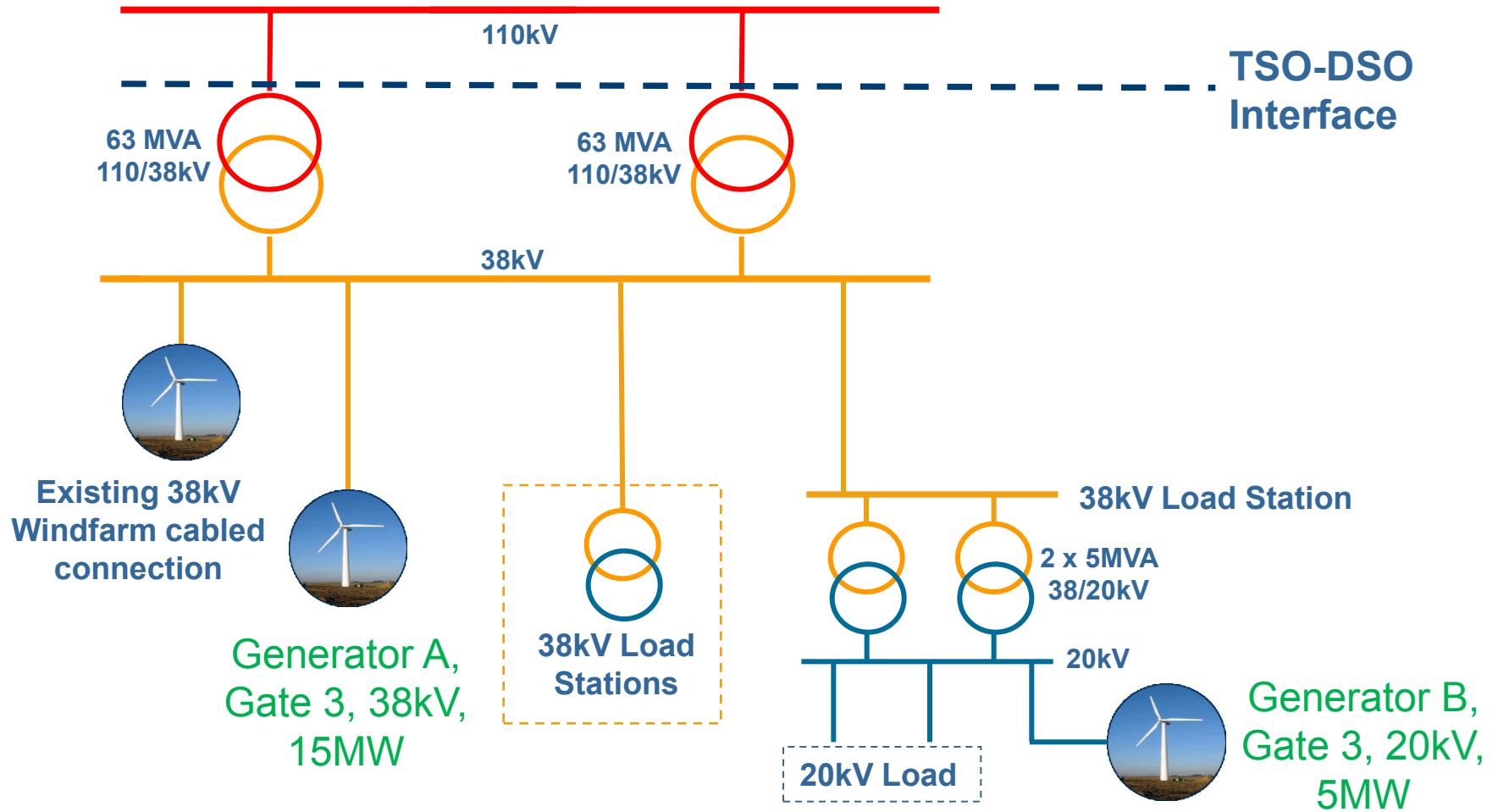

- Eirgrid will provide harmonic voltage distortion limits, background levels and impedance loci applicable at the TSO-DSO Interface, for a number of N-1 conditions on the Transmission System.
- These limits will take background levels into account (from existing generation and load connections).
- N-1 conditions on the Distribution System will be studied
- N-2 contingencies will not be studied (ie a coincident N-1 condition on both Transmission and Distribution systems)

DISTRIBUTION N-1 CONDITIONS

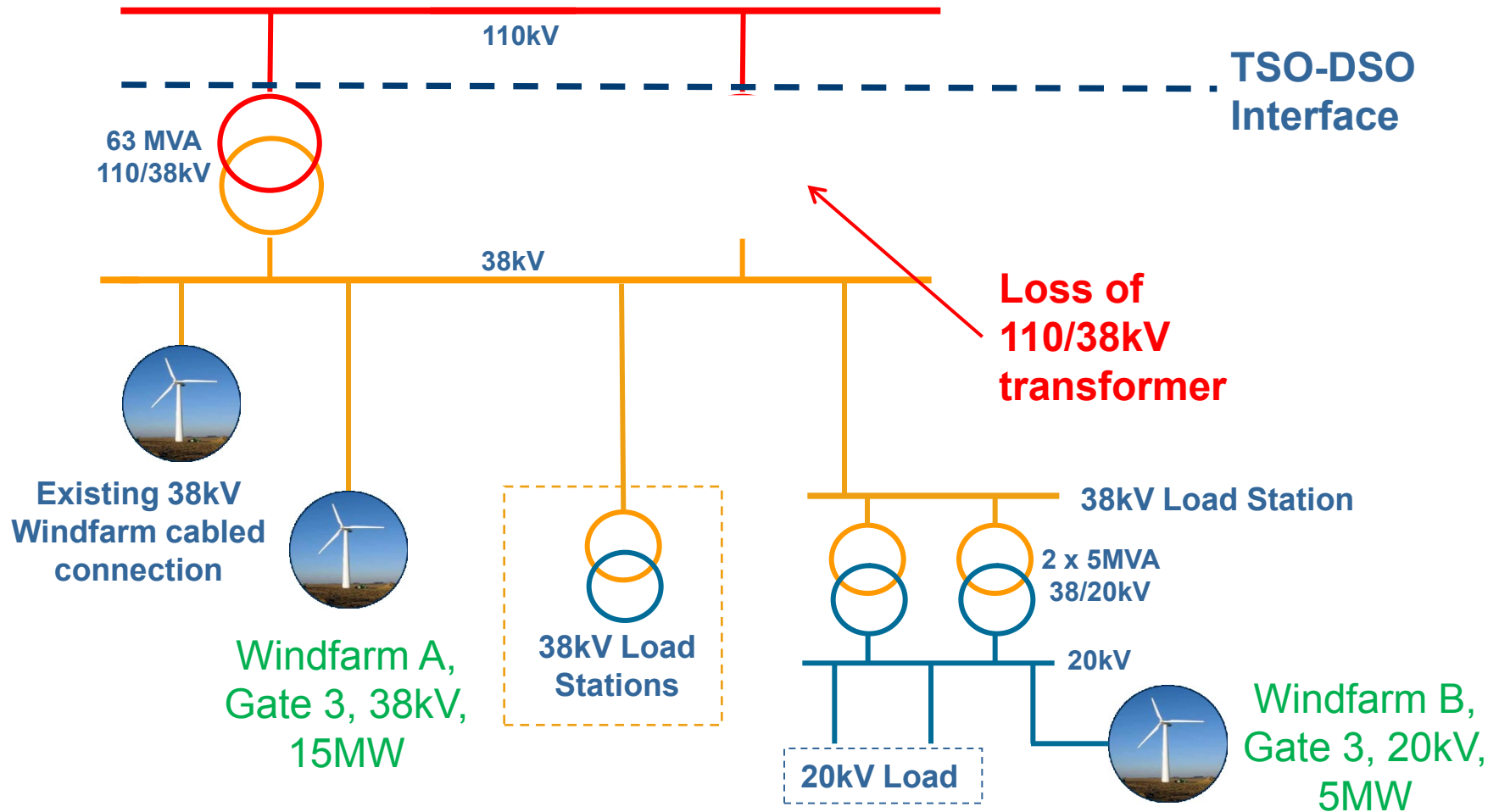

DISTRIBUTION N-1 CONDITIONS

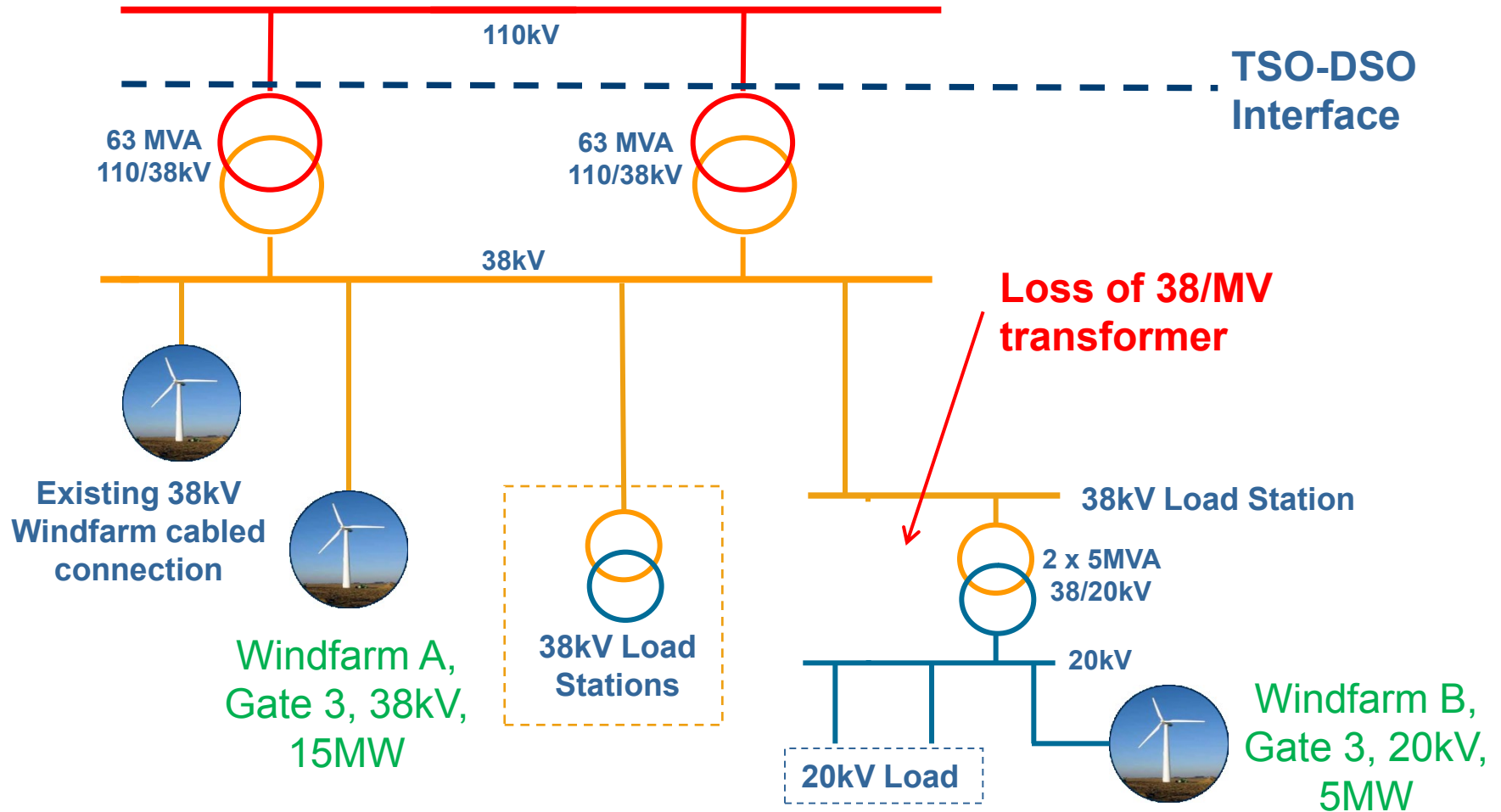

DISTRIBUTION N-1 CONDITIONS

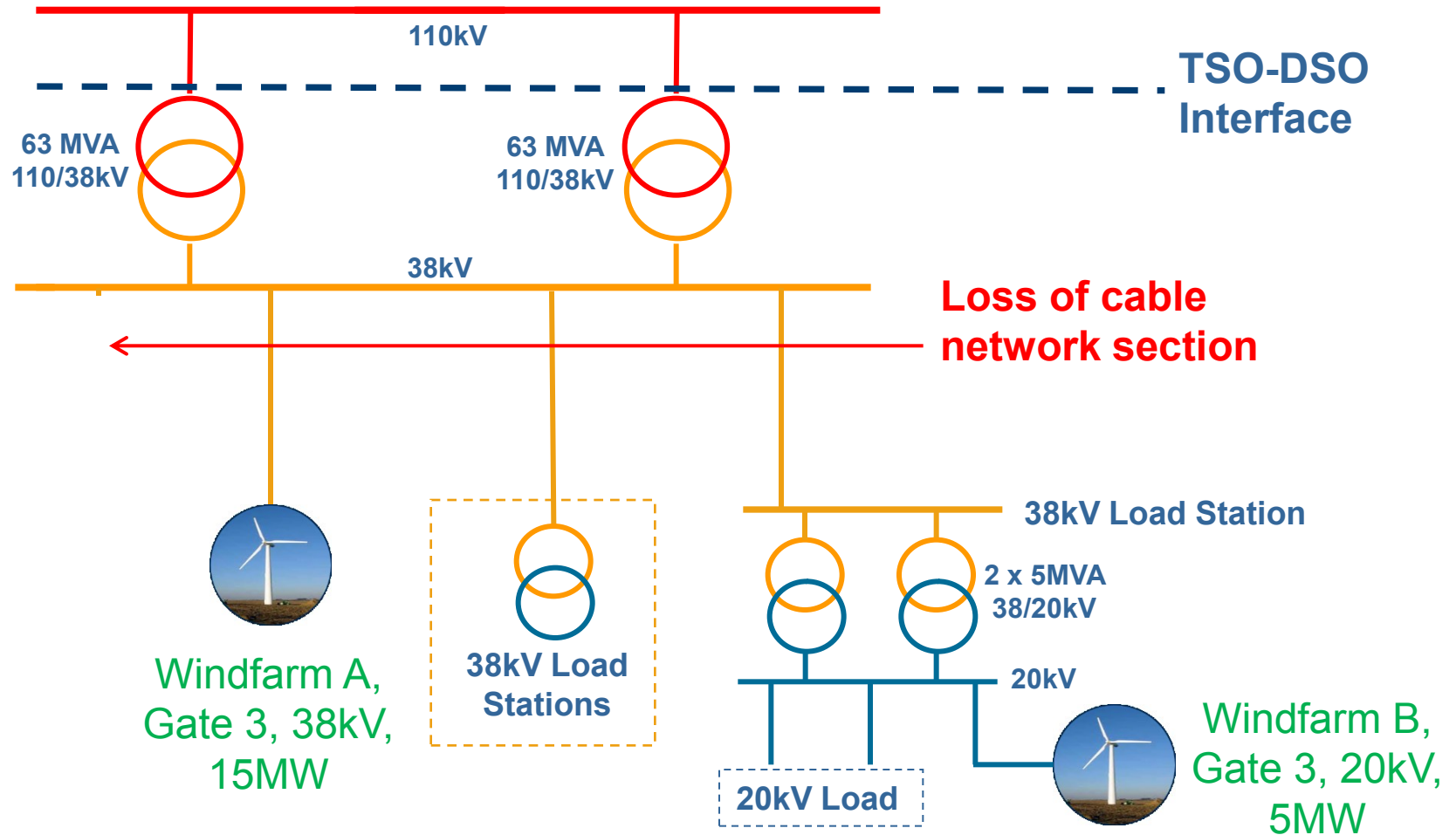

DISTRIBUTION N-1 CONDITIONS

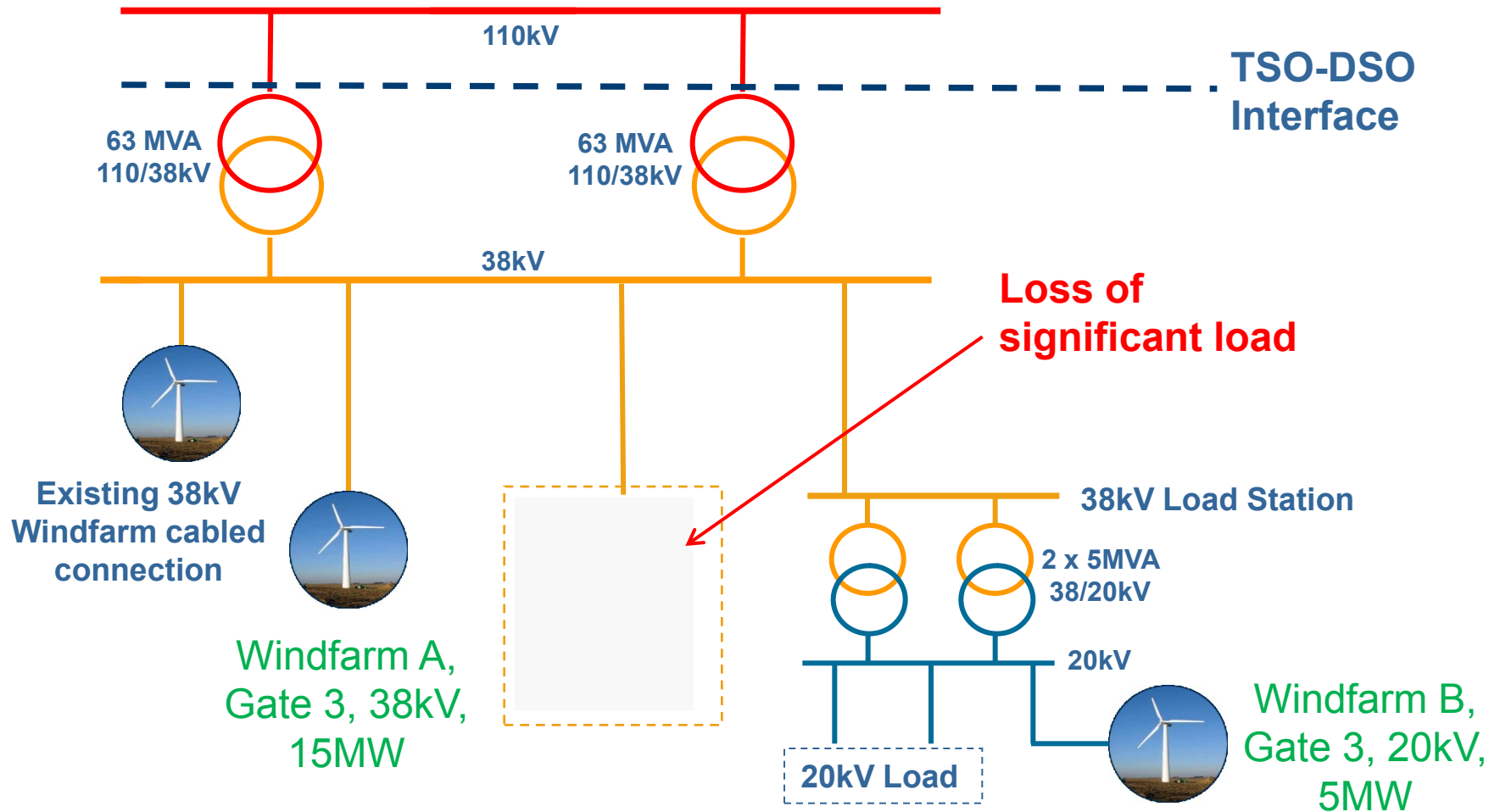

- The equivalent distribution system harmonic distortion limit will be calculated and apportioned to customers, on a per MW basis, eg:
 - Generator A: 75% of limit
 - Generator B: 25% of limit
- The harmonic emission limit at the generator's connection point is calculated taking equivalent impedance of the connecting circuit into account.

FORMAT OF LIMITS TO BE PROVIDED

Allocation of VHD for harmonic orders 2-50

Harmonic Order h	Voltage Harmonic Distortion - Customer Allocation
h	% of actual
2	a
3	b
4	c
5	d
6	e
7	f
...	...
...	...
...	...
...	...
50	g

Impedance Loci for harmonic orders 2-50

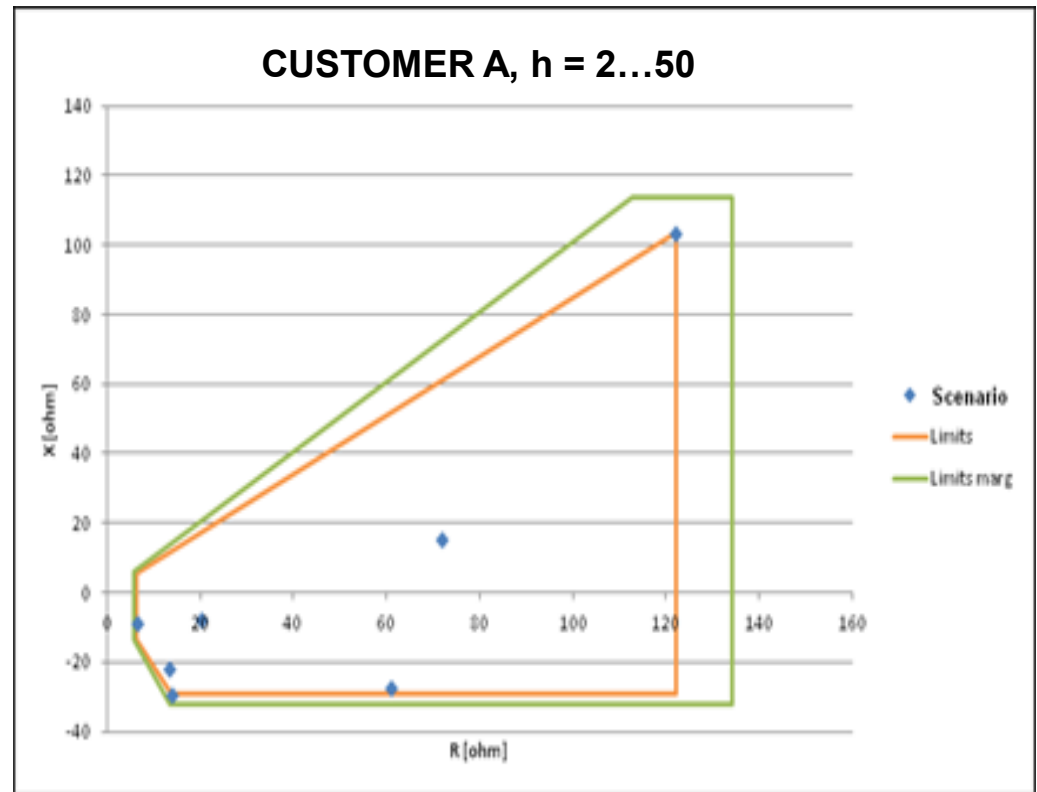

THANK YOU



Session 2



Harmonics Mitigation Options

Marta Val Escudero
Transmission Access Planning



Harmonics Mitigation Options



- First necessary step is to identify and understand the **cause of the problem**:
 - a) Parallel Resonance introduced by the connection of a large capacitive element → **amplification of existing background distortion levels**
 - b) Connection of non-linear equipment without changes in the transmission network → **increase in distortion levels**
 - c) A combination of (a) and (b)
- The **source of the problem and the solution** can be located either at the Transmission/Distribution Network or at the Customer's facility



Harmonics Mitigation Options



Possible mitigation options include:

- Increase System Strength
- Change Point of Connection

SO only

- Transformer Characteristics
- Harmonic Filtering
- Limitation of cable or capacitive elements connections

SO or Customer

- Plant design
- Equipment selection

Customer only

- Equipment design with minimum harmonic emissions

Manufacturers only



Harmonics Mitigation Options



Possible mitigation options include:

- Increase System Strength
- Change Point of Connection

SO only

- Transformer Characteristics
- Harmonic Filtering
- Limitation of cable or capacitive elements connections

SO or Customer

- Plant design
- Equipment selection

Customer only

- Equipment design with minimum harmonic emissions

Manufacturers only



Increase System Strength



The location of a **parallel resonance** is related to the system strength

- Connecting a large capacitive element in a mostly inductive network
→ lower resonance frequency

$$h \approx \sqrt{\frac{MVA_{SC}}{MVA_{r_{CAP}}}}$$

Resonance can be shifted to a higher frequency by increasing system strength.
Caution: weak areas require a significant reinforcement to have material impact.

Theoretical example of the radial connection of 20km of 110kV underground cable

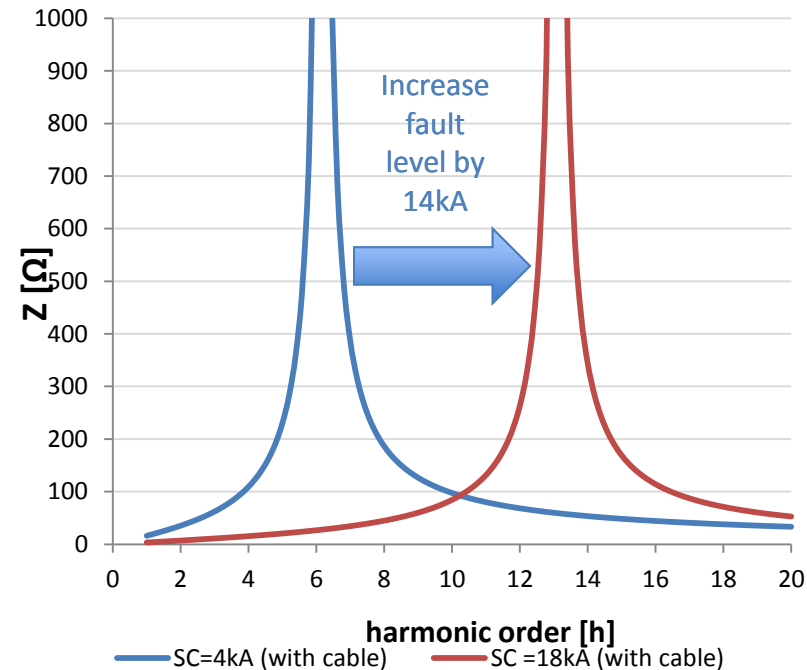
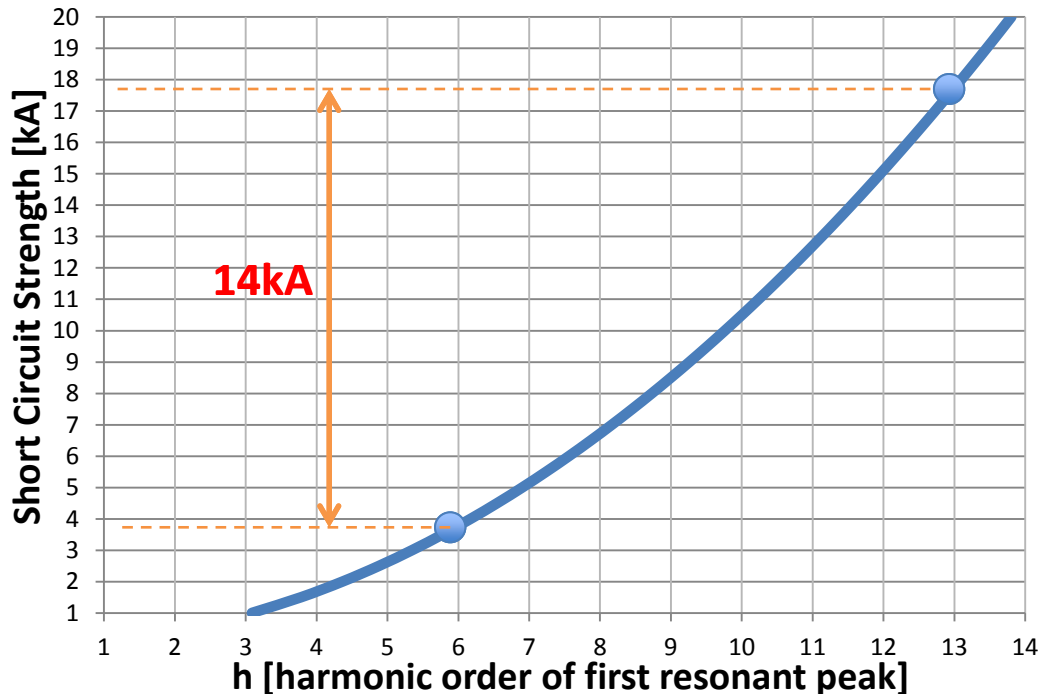

Increase System Strength



Methods of increasing system strength:

- ❖ Can be costly and often have long lead times
 - Building new circuits
 - Installing more transformers from a higher voltage level
 - Connecting (stiff) generation into the area
- Caution with increasing system strength – adequate rating of switchgear?
- General principle to apply to system strength is:
“As High as Necessary, but As Low as Possible”



Harmonics Mitigation Options



Possible mitigation options include:

- Increase System Strength
- Change Point of Connection

SO only

- **Transformer Characteristics**
- Harmonic Filtering
- Limitation of cable or capacitive elements connections

SO or Customer

- Plant design
- Equipment selection

Customer only

- Equipment design with minimum harmonic emissions

Manufacturers only



Transformer Winding Connections



- High order harmonics are not typically passed through transformers. Transformers effectively attenuate high harmonic frequencies.
- Triplen harmonics are typically trapped in transformer delta connected windings (assuming balanced loading conditions).
- **Caution with triplen harmonic flows on the neutral conductor.**

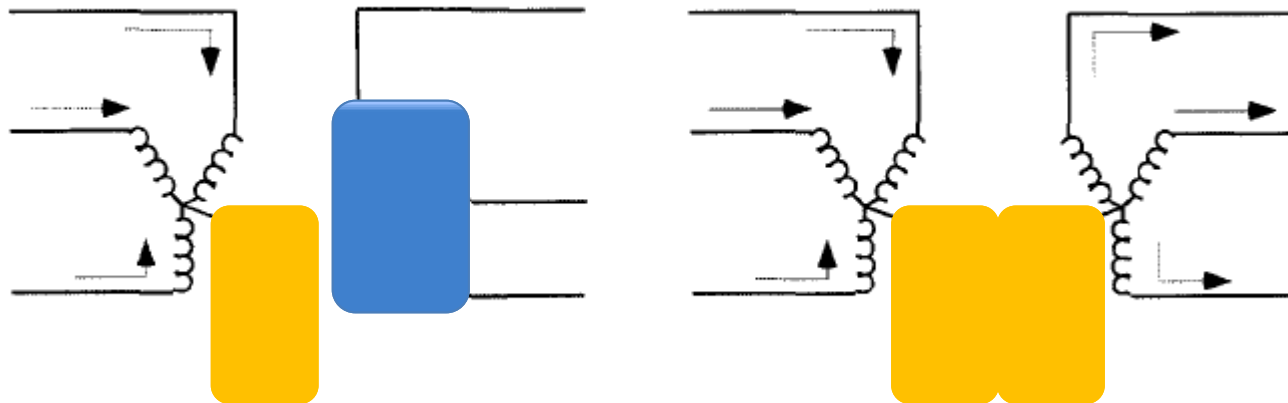

Harmonics Mitigation Options



Possible mitigation options include:

- Increase System Strength
- Change Point of Connection

SO only

- Transformer Characteristics

- **Harmonic Filtering**

SO or Customer

- Limitation of cable or capacitive elements connections

- Plant design
- Equipment selection

Customer only

- Equipment design with minimum harmonic emissions

Manufacturers only



Shunt Passive Filters



- “Catch” (or shunt) some of the harmonic current from the non-linear source into the filter.
- “Harmonic absorption” is a function of the filter design and the network impedance.
- **Need to design the filter with a low impedance path for harmonic currents at the desired frequencies and maintain performance under all possible network operating conditions.**
- Comprised of R, L and C
Tuned to single harmonic or filter banks

Caution: Capacitive behaviour at 50Hz

→ Voltage control

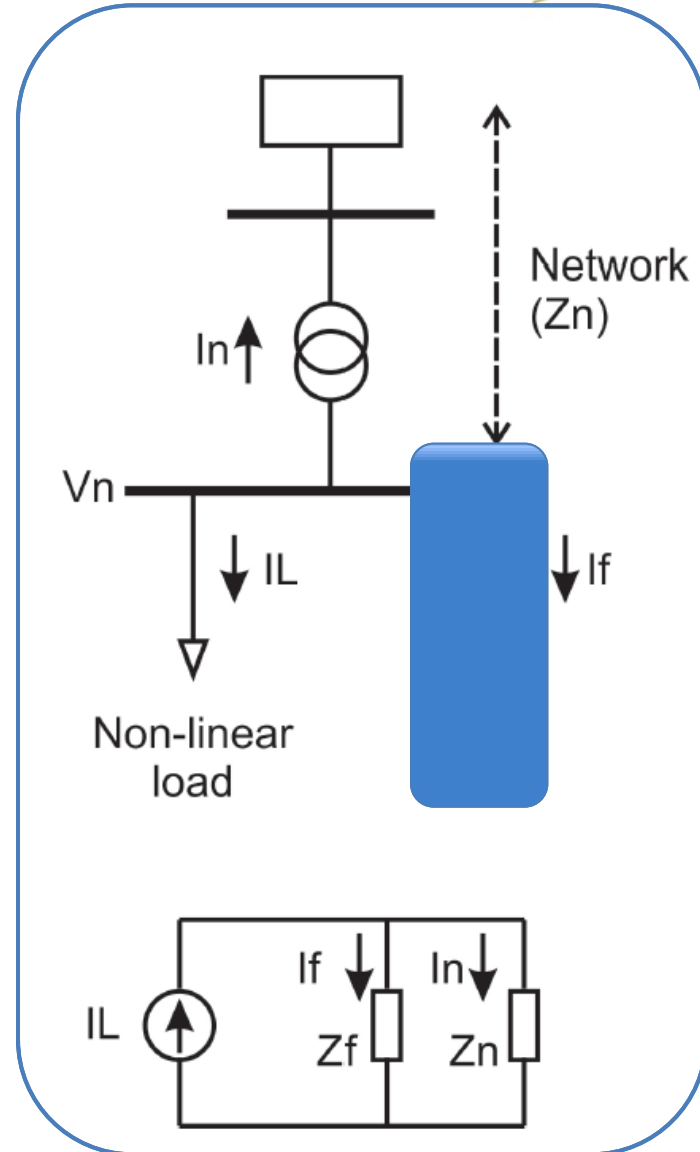

Shunt Passive Filters



- Tuned Filters

Single Tuned

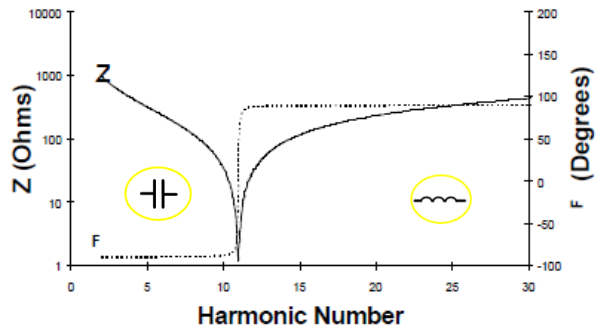
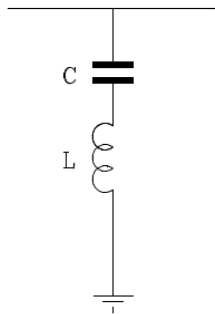

Double Tuned

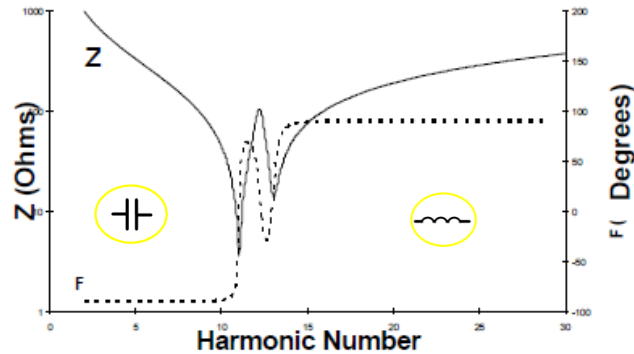
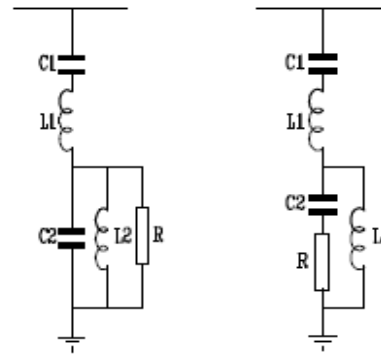

Triple Tuned

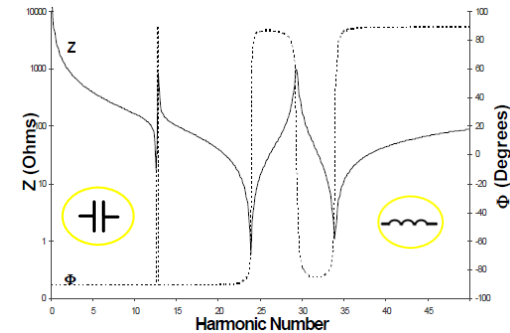
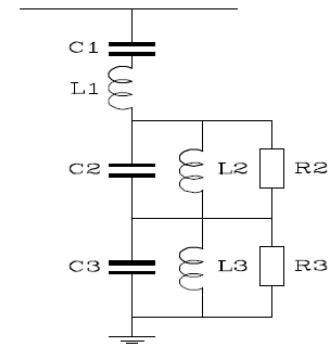

Shunt Passive Filters (iv)



- Damped filters

2nd Order Damped

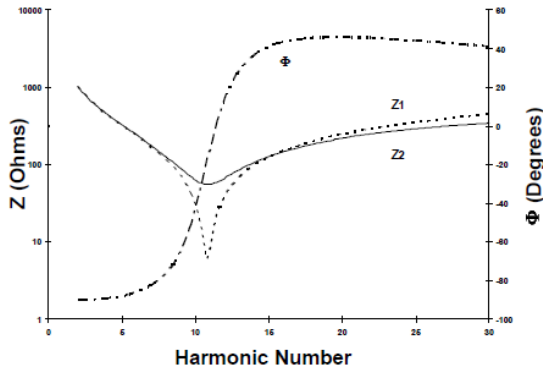
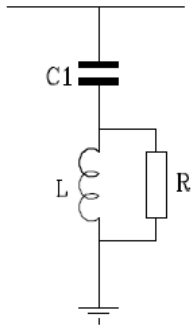

3rd Order Damped

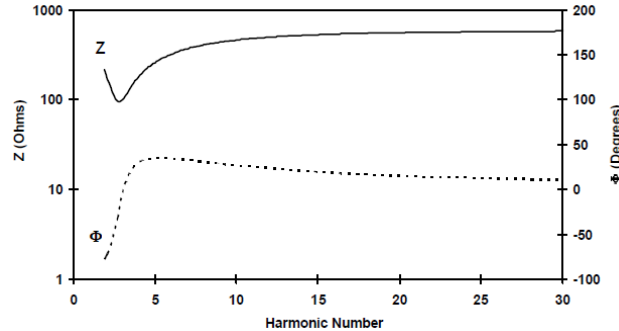
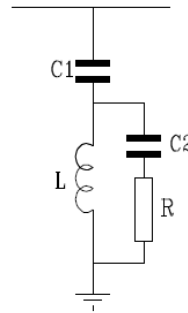

C-Type

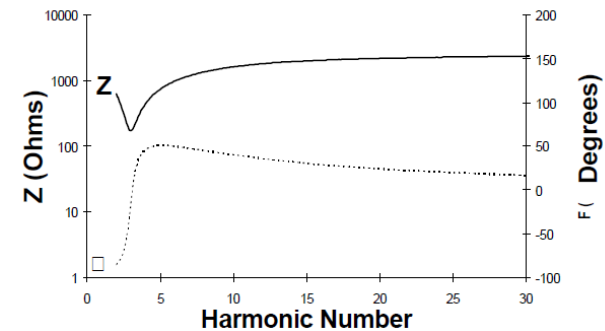
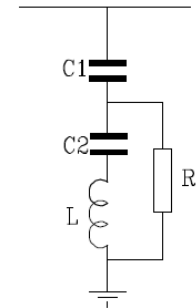

Active Filters



- Based on power electronic converters that dynamically cancel harmonic current. The device measures the load current, calculates the harmonic current spectrum and then injects the required signal at the opposite phase angle for each selected harmonic order to be cancelled.
- These devices are costly and are typically applied in the electric distribution networks of industrial plants.
- No experience of application of active filters in transmission networks to date.



Other harmonic mitigation options



- Impose limitation on the harmonic voltage distortion that can be introduced by a Customer's connection - **Aimed to prevent excessive offending currents from entering the grid**
 - ❖ Can be Achieved by:
 - selecting equipment with minimal harmonic current emission and/or
 - installing filters to prevent on-site emissions from reaching the external grid
- Connect via Overhead Line (as resonances typically occur at higher frequencies)
- Select an alternate converter (different number of pulses, materials etc)



Application Example



Amplification of Background Distortion Due to Customer's Internal Network

Harmonic Order	Existing Background [%]	Emission Limit [%]	Planning Level [%]
n	1.16	0.5	2

$$\text{Voltage Amplification Factor} = \frac{Z_{customer}}{Z_{customer} + Z_{Network}}$$

$$\text{Voltage Amplification Factor} = \frac{4 - j48}{(4 - j48) + (1.5 - j50)} = 8.23$$

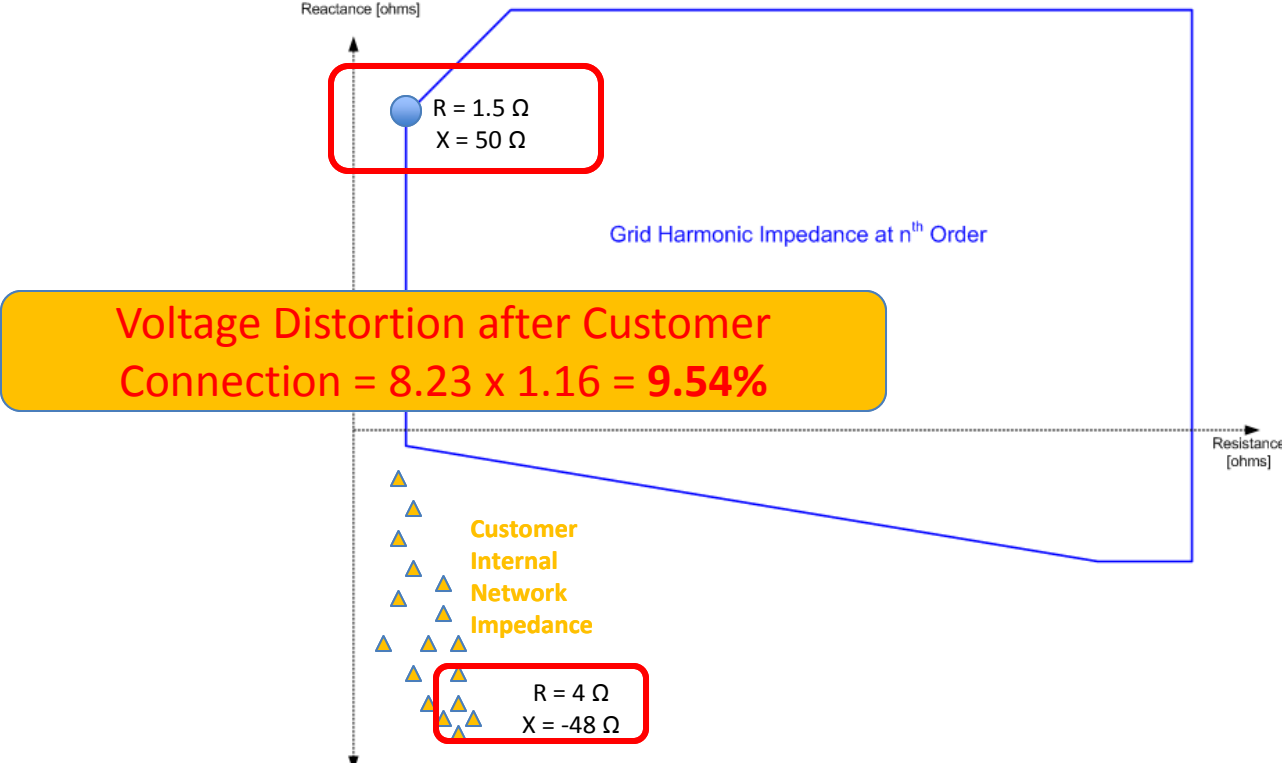
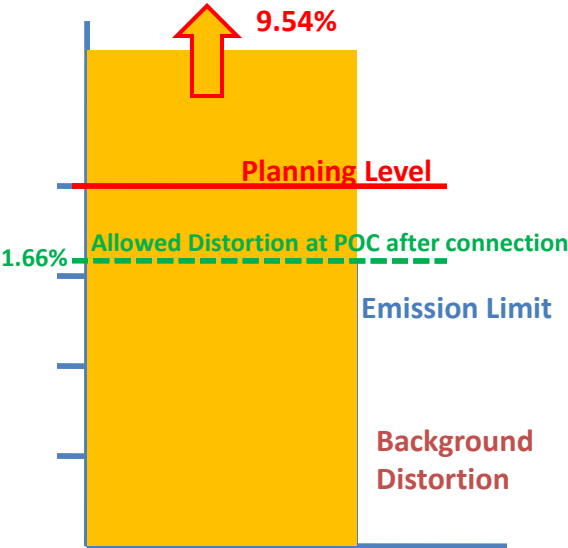

Application Example (cont.)



Amplification of Background Distortion Due to Customer's Internal Network

Harmonic Order	Existing Background [%]	Emission Limit [%]	Planning Level [%]
n	1.16	0.5	2

$$\text{Voltage Amplification Factor} = \frac{Z_{\text{customer}}}{Z_{\text{customer}} + Z_{\text{Network}}}$$

$$\text{Voltage Amplification Factor} = \frac{4 - j29.68}{(4 - j29.69) + (1.5 - j50)} = 1.422$$

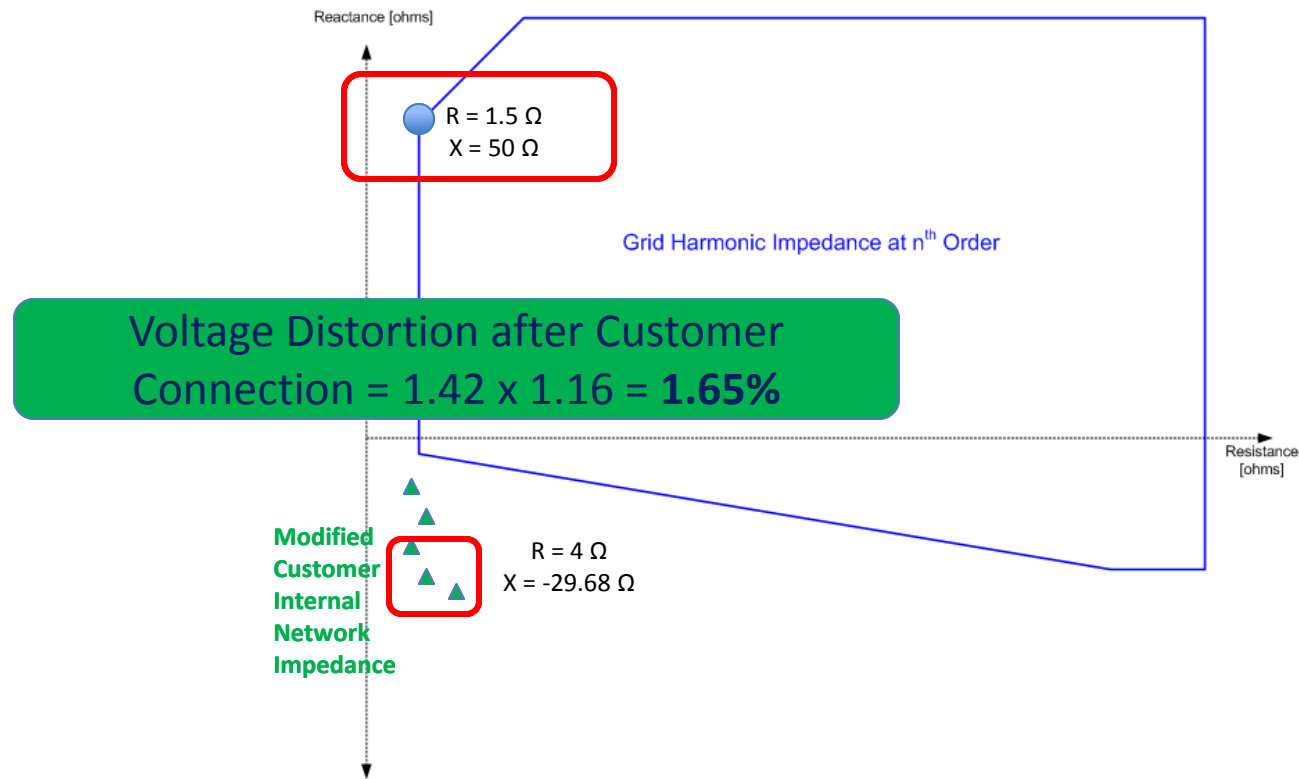
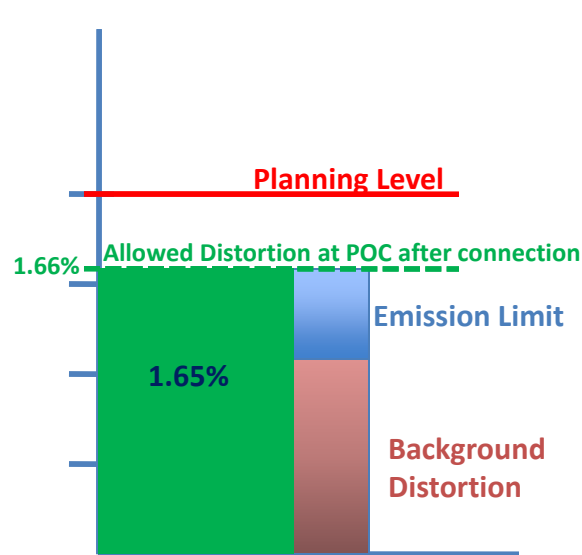

A filter can be employed to modify the Customer's facility internal network Impedance



z [Ω]

Filter Example

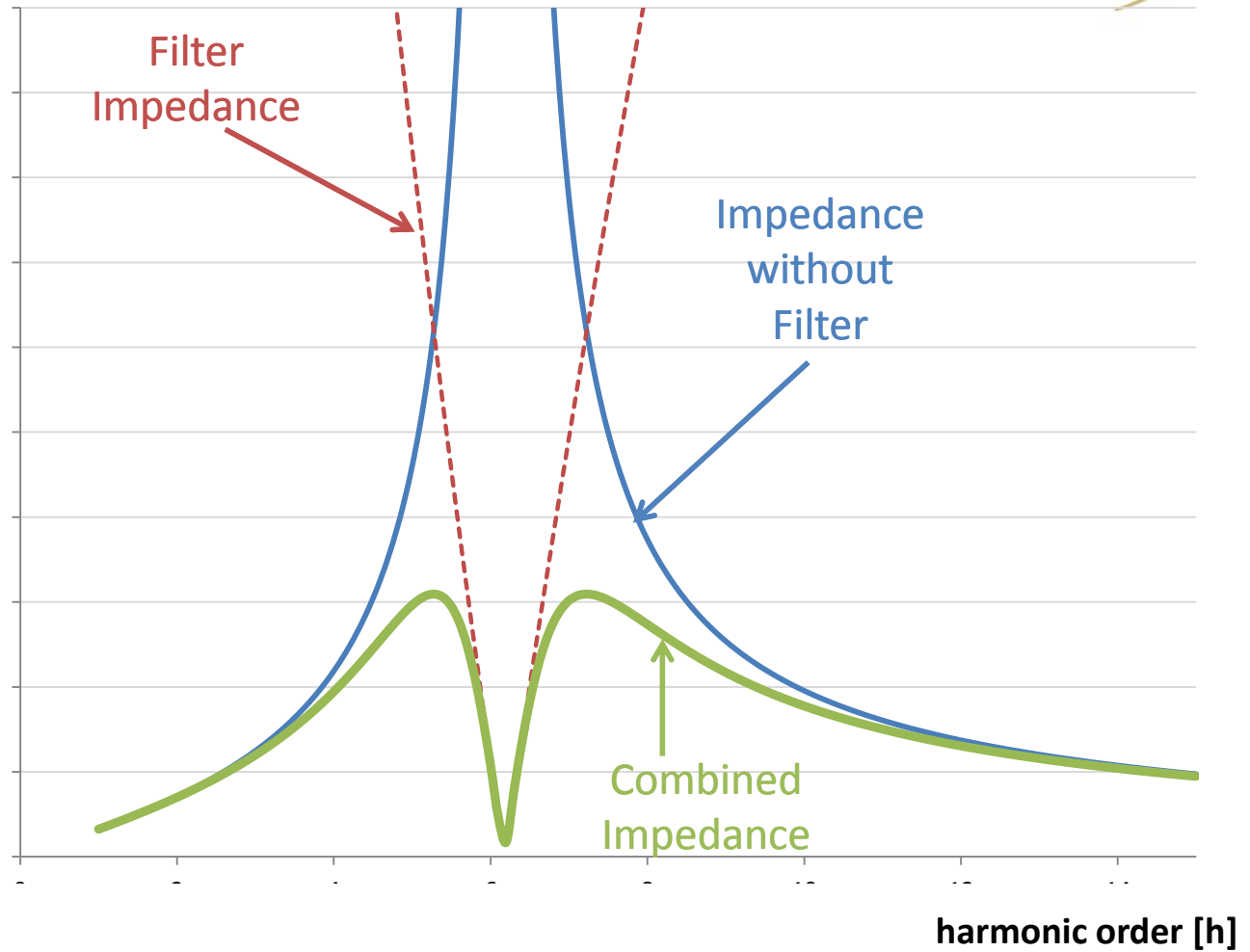
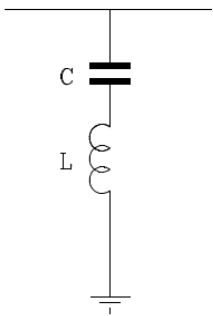

.... but it is not the only possible solution!!



Monitoring Transmission System Power Quality

Ray Doyle
EirGrid



Overview of the Technology



- Disturbance Recorders with Power Quality functions
- Utilise protection or energy metering CT and VTs
- Devices Monitor:
 - Voltage dips, swells, Supply interruptions
 - Voltage and Current harmonics



Locations Monitored

- Devices installed at 40+ Nodes
- Automatic reporting of
 - System disturbances
 - Power quality outside of IEC/Grid Code limits
 - Monthly voltage harmonics
- Additional portable Disturbance Recorders recently acquired



TRANSMISSION SYSTEM 400KV, 275KV, 220KV AND 110KV - JANUARY 2011

- 400KV Lines
- 275KV Lines
- 220KV Lines
- 110KV Lines
- 220KV Cables
- 110KV Cables
- 400KV Stations
- 275KV Stations
- 220KV Stations
- 110KV Stations
- ⊕ Phase Shifting Transformer
- Transmission Connected Generation
 - Hydro Generation
 - Thermal Generation
 - ▼ Pumped Storage Generation
 - Wind Generation
- Installed Disturbance Recorder

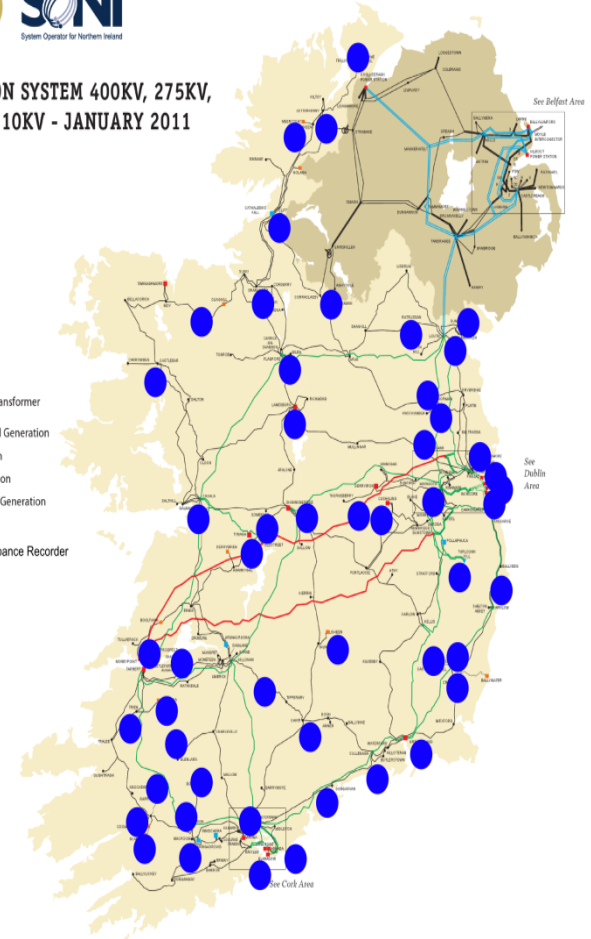

Voltage Harmonic Measurements



- Example variation at 110 kV Wind Farm

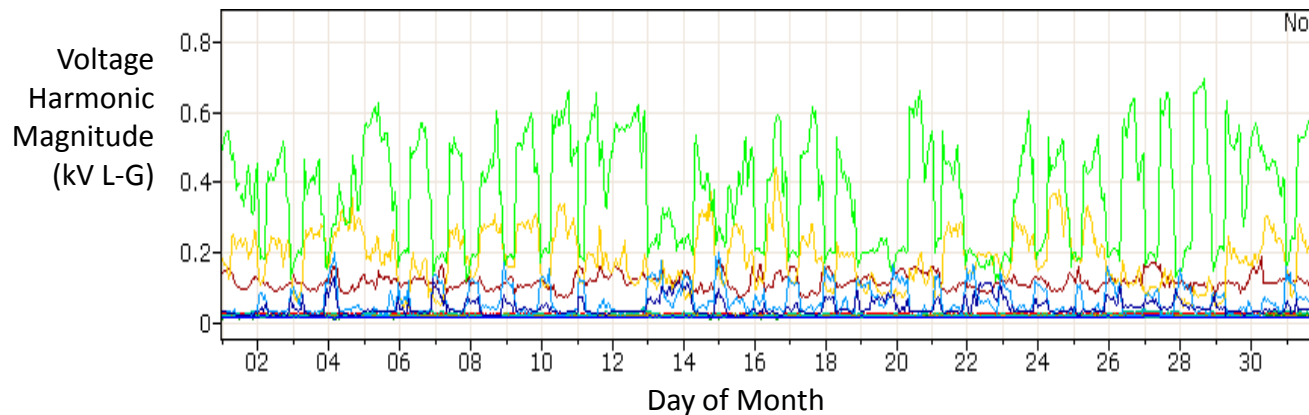

Green: 7th Harmonic
Yellow: 5th Harmonic
Red, blue etc.: Other

Current Harmonic Magnitude (A)

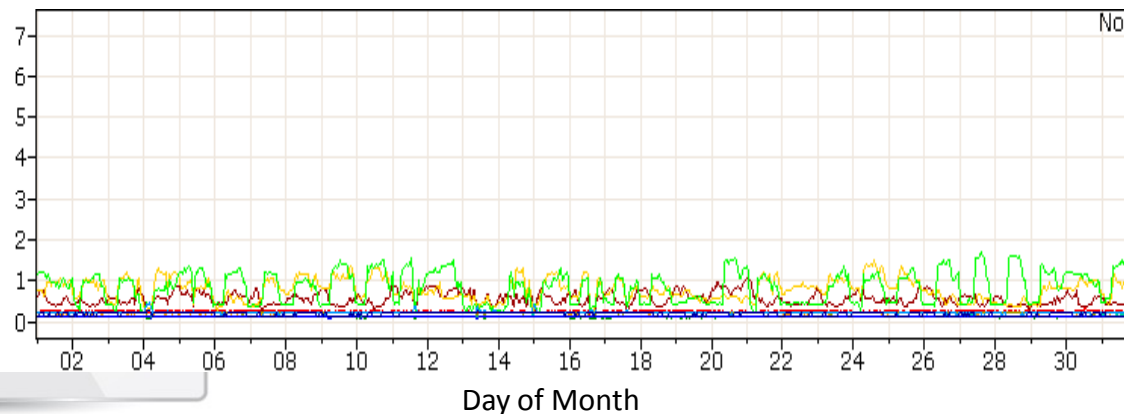

Green: 7th Harmonic
Yellow : 5th Harmonic
Red, blue etc.: Other



Harmonic status



- **No issues of breaching IEC recommendation on the network today**
- **Recent DR data used as background harmonic level to set up and tune the Digsilent models**



Voltage Harmonics: North-West Region

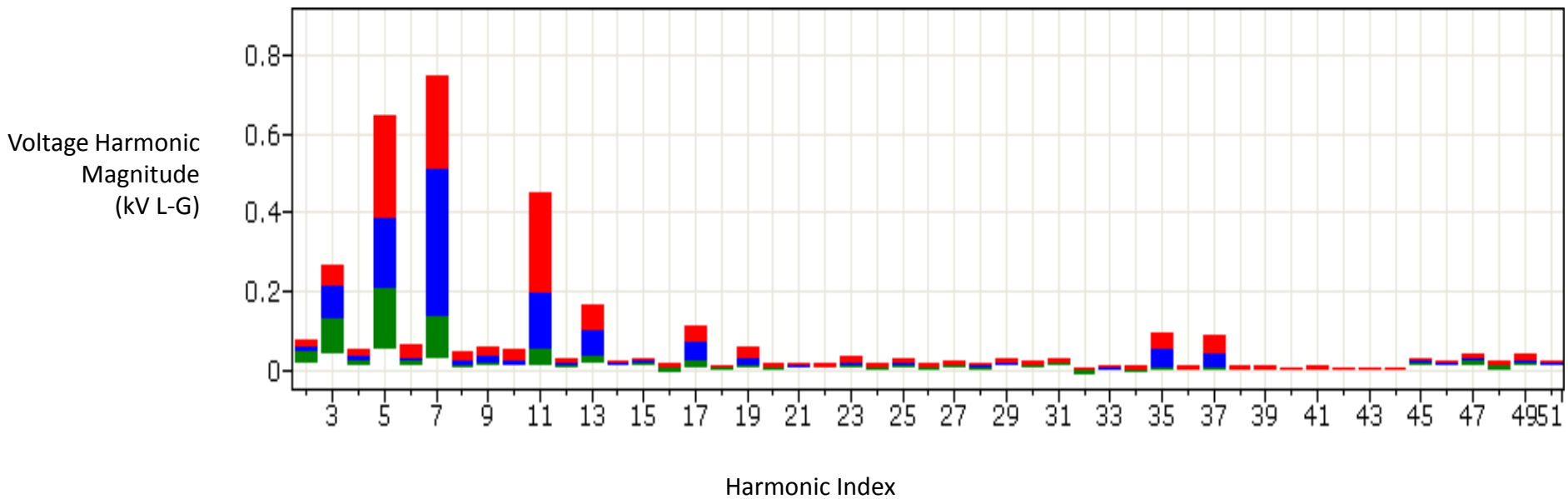

Red: Instantaneous peak over measurement period
Blue: 95th percentile magnitude (used for IEC61000-3-6)
Green: Average magnitude



Voltage Harmonics: South-West Region

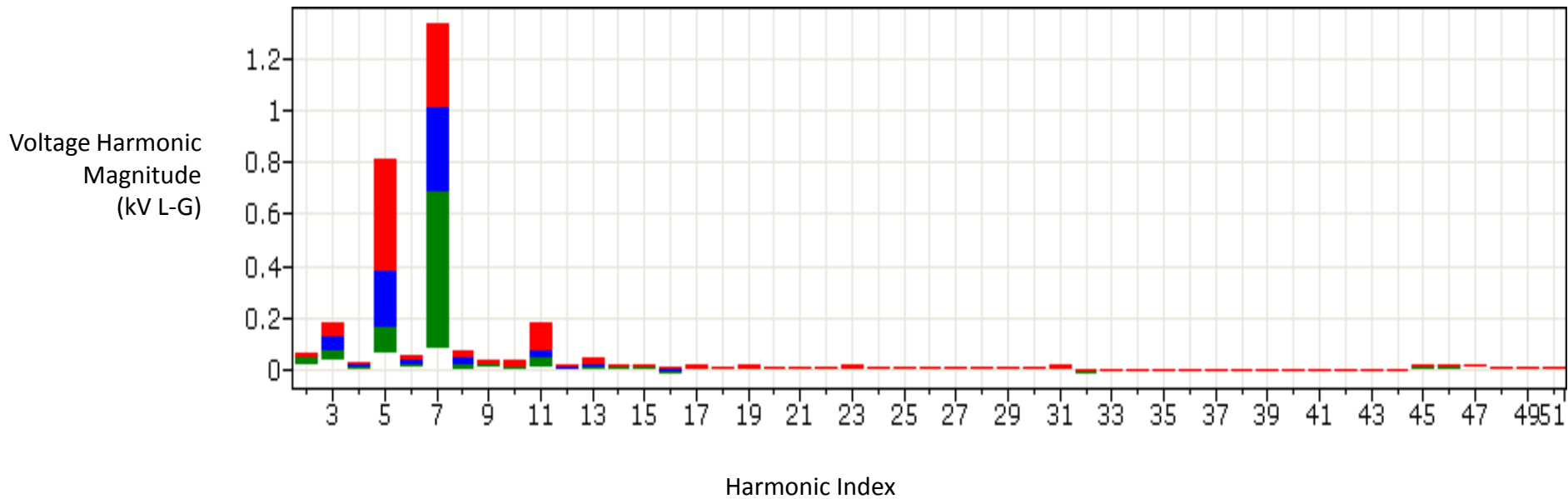

Red: Instantaneous peak over measurement period
Blue: 95th percentile magnitude (used for IEC61000-3-6)
Green: Average magnitude



Voltage Harmonics: North-East Region

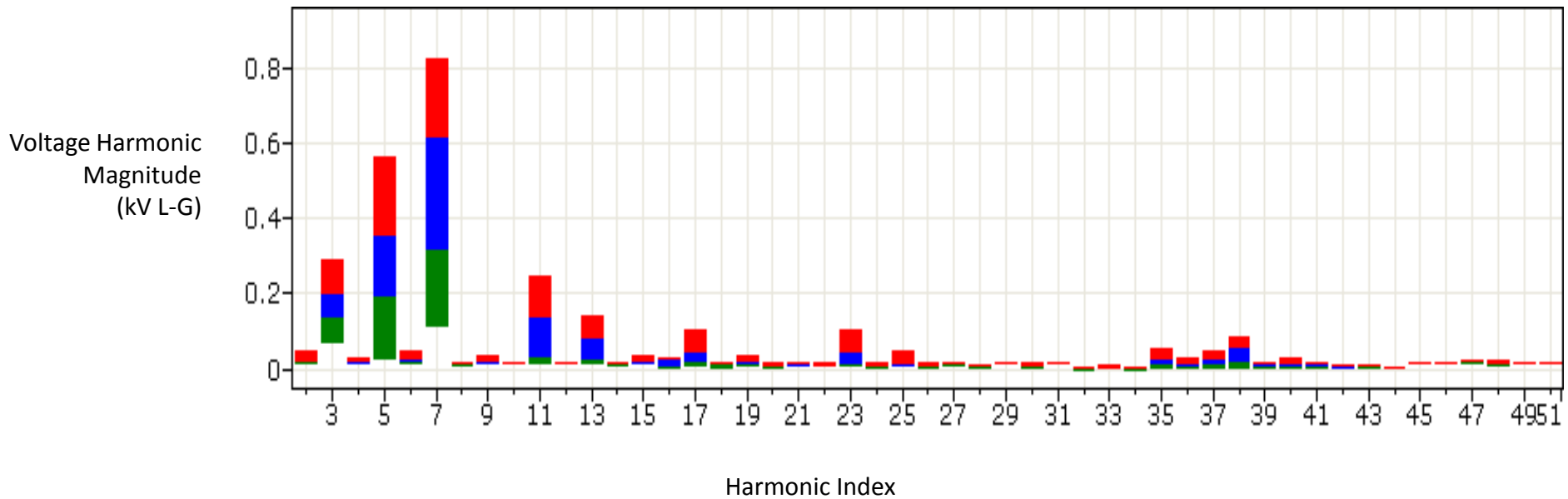

Red: Instantaneous peak over measurement period
Blue: 95th percentile magnitude (used for IEC61000-3-6)
Green: Average magnitude



Voltage Harmonics: South-East Region

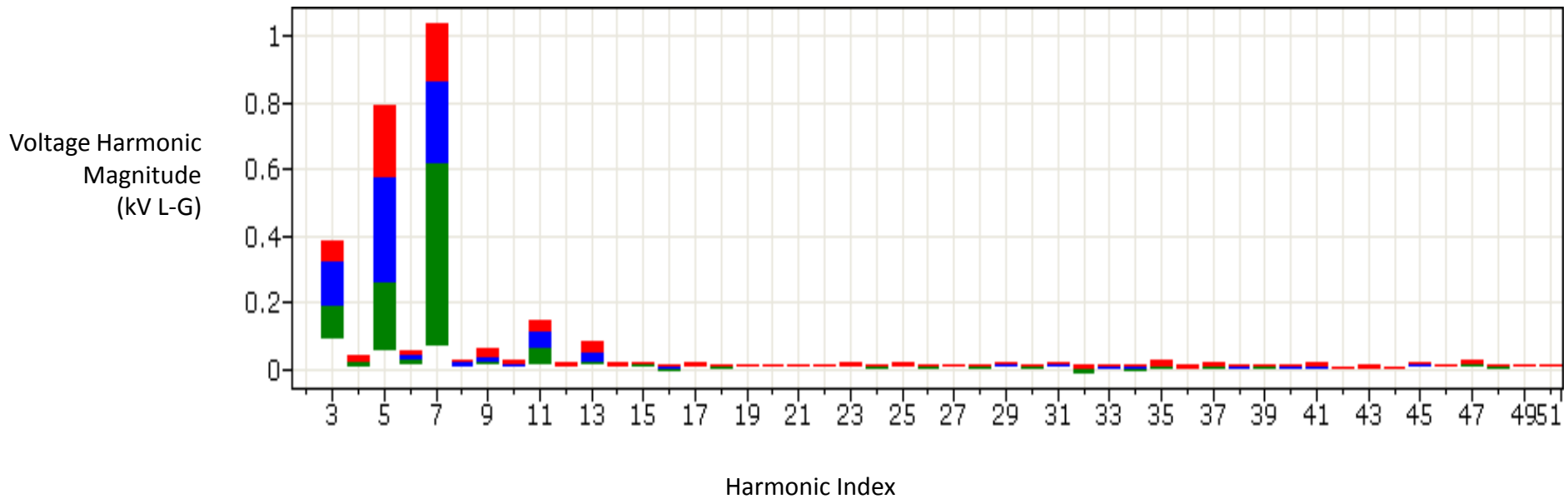

Red: Instantaneous peak over measurement period
Blue: 95th percentile magnitude (used for IEC61000-3-6)
Green: Average magnitude



On-going monitoring



- IEC recommendation to have a DR in place at a suitable transmission node at least 7 days prior to energisation of customer site
 - i.e. create background readings pre-connection
- DR provides on-going monitoring thereafter



Charging for Harmonics

Marie Hayden
Connection Contracts & Tariffs
21 November 2013



What is Connection Charging



- Recovery of shallow asset capital costs associated with customer connections.
- Focused on transmission assets required up to the meshed system.
- Governed by a number of regulatory approved policy documents which set out high level principles for the assigning of costs.



Connection Charging: Basics



- Charging is applied on a *Least Cost Chargeable* (LCC) basis – charge may not correspond to the actual build.
 - Example Grid West Project: a 220kV line is required to connect Gate 3 wind and is charged to customers as LCC; Actual build is 400kV to cater for future needs and TUoS picks up the difference in cost
- Assets not driven exclusively by a given customer/subgroup are considered “deep”
 - Example – upgrading of meshed transmission system lines



Deep Asset Charging



- Connection Charging Methodology Statement outlines that a customer will be required to pay for any additional cost associated with customer requested connection method which differs from the LCC, including any additional system costs.
 - Example – customer requests a change in connection method from overhead line to underground cable and this drives additional reactive power support assets to be built



Harmonics issues in a charging context



- The requirement to install a transmission reinforcement (e.g a Filter Bank) to manage a harmonic issues is often driven by use of underground cable
- If use of cable is at customer request then per existing policy the cost of any required reinforcement is chargeable to the customer
- If harmonic solutions are optimised on a geographic basis, are deep in the system and mitigate harmonics for a number of applicants, how do we assign costs?



Upcoming Consultation



- We have existing high level charging principles approved by SEM-Committee that will be interpreted based on the specifics of this issue.
- EirGrid will run a consultation process to gather views on how existing principles should be interpreted
- The resulting approach needs to:
 - Be fair and proportional.
 - Send a signal about the cost that cable requests impose on the system.
 - Be relatively simple to apply, not requiring a suite of “charging” power quality studies.



Options being considered

Option 1: Charge for the technical solution identified



Pros:

- Entirely cost reflective

Cons:

- Would require additional “charging” power quality studies to determine “drivers” and the extent to which individual subgroups/applicants are contributing to optimised solutions
- Extremely complex from a charging & rebating perspective



Option 2: Apply a Least Cost approach



Example

- Charge for a filter bank at the point of connection to the meshed system where the connection exceeds harmonics limits.

Pros:

- Consistent with the LCC principle, pay for the lowest cost solution to the problem, regardless of what is ultimately installed.
- Clear, transparent and well understood

Cons:

- May not be entirely cost reflective in all cases.



Option 3: Apply a harmonics levy



Proposal

- Apply a levy on all requests for cable regardless of impact on the system.

Pros:

- Reflects that harmonics issues are cumulative
- Clear & transparent, avoids rebating complexity

Cons:

- Customers that request cable in an area of low underlying harmonics pay the same as in high areas
- Not consistent with charging to date



Option 4: Socialise the cost



Proposal

- Recover the cost of harmonics mitigation via TUoS charges where such solutions are found to be System Assets under the application of the charging rules. Under this option customers/subgroups could request cable with the cost of associated system reinforcements borne by the end user.

Pros:

- Would recognise the difficulty in determining causation in relation to System Assets.

Cons:

- Would not ensure that the customer requesting a non-LCC solution bears the additional cost and therefore contradicts approved charging principles



Next steps



- A consultation paper will be published for industry comment
- Timelines
 - Aiming to publish by 1st week in December
 - Regulatory review and approval by Q1 2014







Programme Update and Customer Communications

Brendan Kelly
Transmission Access Planning



Agenda



Overview of Harmonics Programme Plan

Types of Studies to be performed

Proposed Procedure for Studies

What the TSO expects of the customer?

What the customer should expect from the TSO?



Harmonics Programme Update

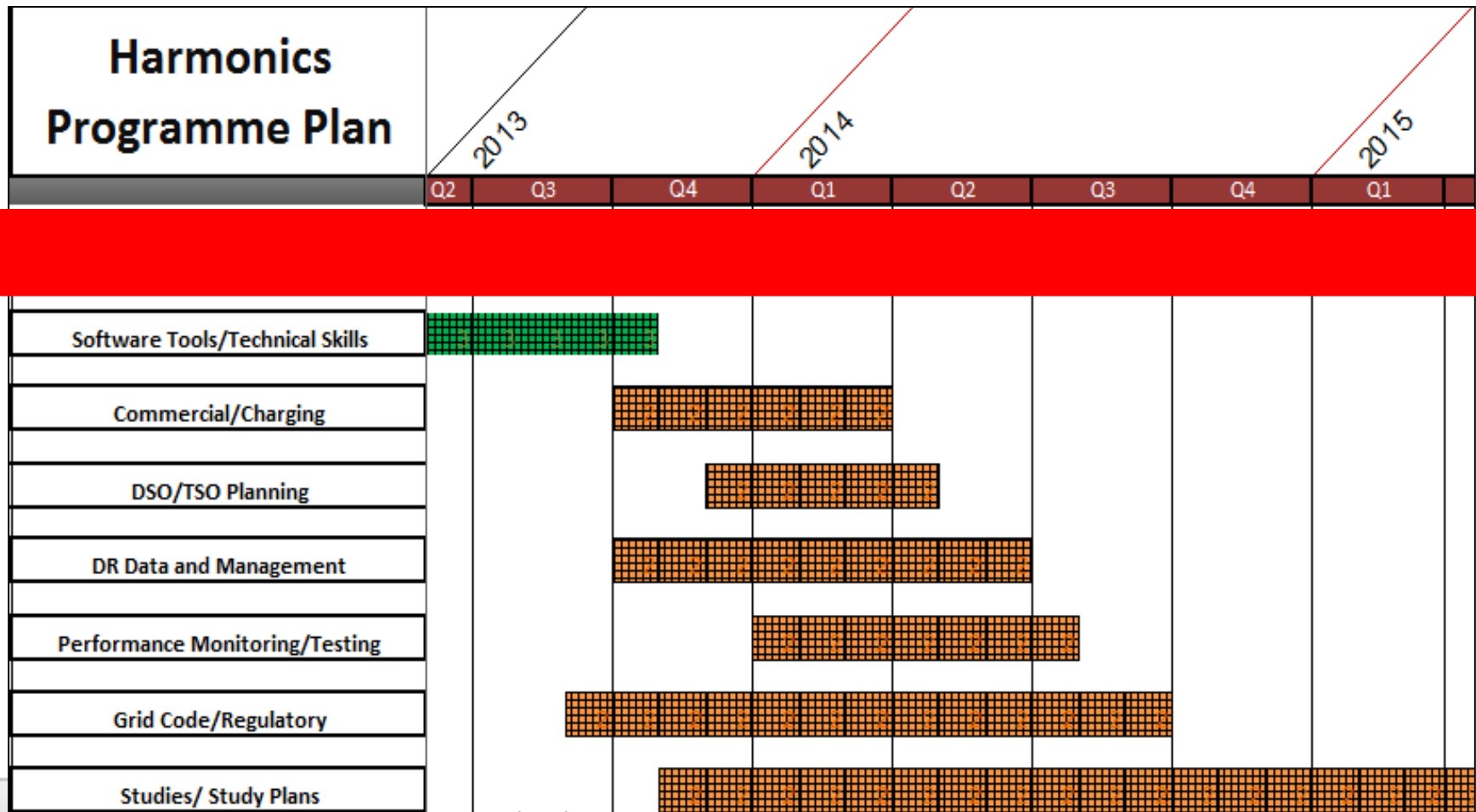

Harmonics Programme Update



Harmonics Programme Plan	2013			2014			2015		
	Q2	Q3	Q4	Q1	Q2	Q3	Q4	Q1	
Policies/Methodologies	[Green grid]								
[Redacted]									
Commercial/Charging			[Orange grid]						
DSO/TSO Planning			[Orange grid]						
DR Data and Management			[Orange grid]						
Performance Monitoring/Testing			[Orange grid]						
Grid Code/Regulatory		[Orange grid]			[Orange grid]				
Studies/ Study Plans		[Orange grid]			[Orange grid]			[Orange grid]	

Software Tools/Technical Skills



- Software tools

- PowerFactory Software Package chosen
- Advanced Training Course on Harmonics Studies
- Tools Created for Determining Voltage Harmonics Limits



- Technical Up-skilling

- Liaised with other TSO's, e.g Energinet DK, National Grid
- Discussions with Industry Experts
- Reviewing Technical Papers and Documentation



Harmonics Programme Update



Harmonics Programme Plan	2013			2014				2015
	Q2	Q3	Q4	Q1	Q2	Q3	Q4	Q1
Policies/Methodologies	█	█	█					
Software Tools/Technical Skills	█	█	█					
DSO/TSO Planning				█	█			
DR Data and Management			█	█	█	█		
Performance Monitoring/Testing				█	█	█		
Grid Code/Regulatory		█	█	█	█	█	█	
Studies/ Study Plans			█	█	█	█	█	█



Harmonics Programme Update



Harmonics Programme Plan	2013			2014			2015		
	Q2	Q3	Q4	Q1	Q2	Q3	Q4	Q1	
Policies/Methodologies	█	█	█	█					
Software Tools/Technical Skills	█	█	█	█					
Commercial/Charging			█	█	█				
DR Data and Management			█	█	█	█			
Performance Monitoring/Testing				█	█	█			
Grid Code/Regulatory		█	█	█	█	█	█		
Studies/ Study Plans			█	█	█	█	█	█	



DSO/TSO Planning



- Sharing Measured VHD Data
- Agree Means of Issuing Limits
- Study Methodologies/Policy
- Alignment of Distribution Code and Grid Code Modifications



Harmonics Programme Update

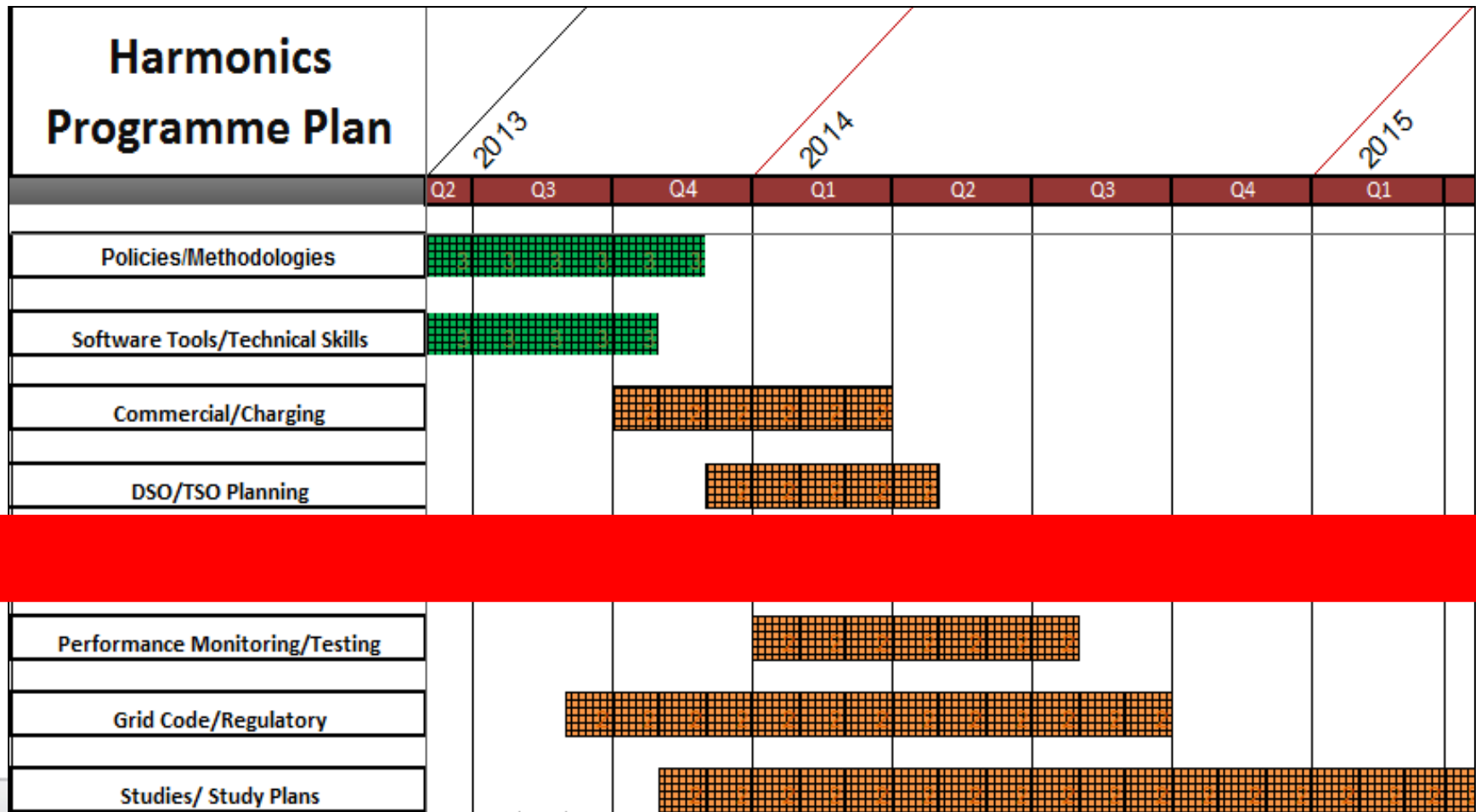

Disturbance Recorder (DR) Data and Data Management



- Roll out of more Disturbance Recorders over next 12 months
 - Portable Disturbance Recorders which can be installed at short notice
- Aid in Validation of Network Model
 - Measurements in reality are replicated in the Network Model
- Review existing Disturbance Recorder Data on an ongoing basis



Harmonics Programme Update

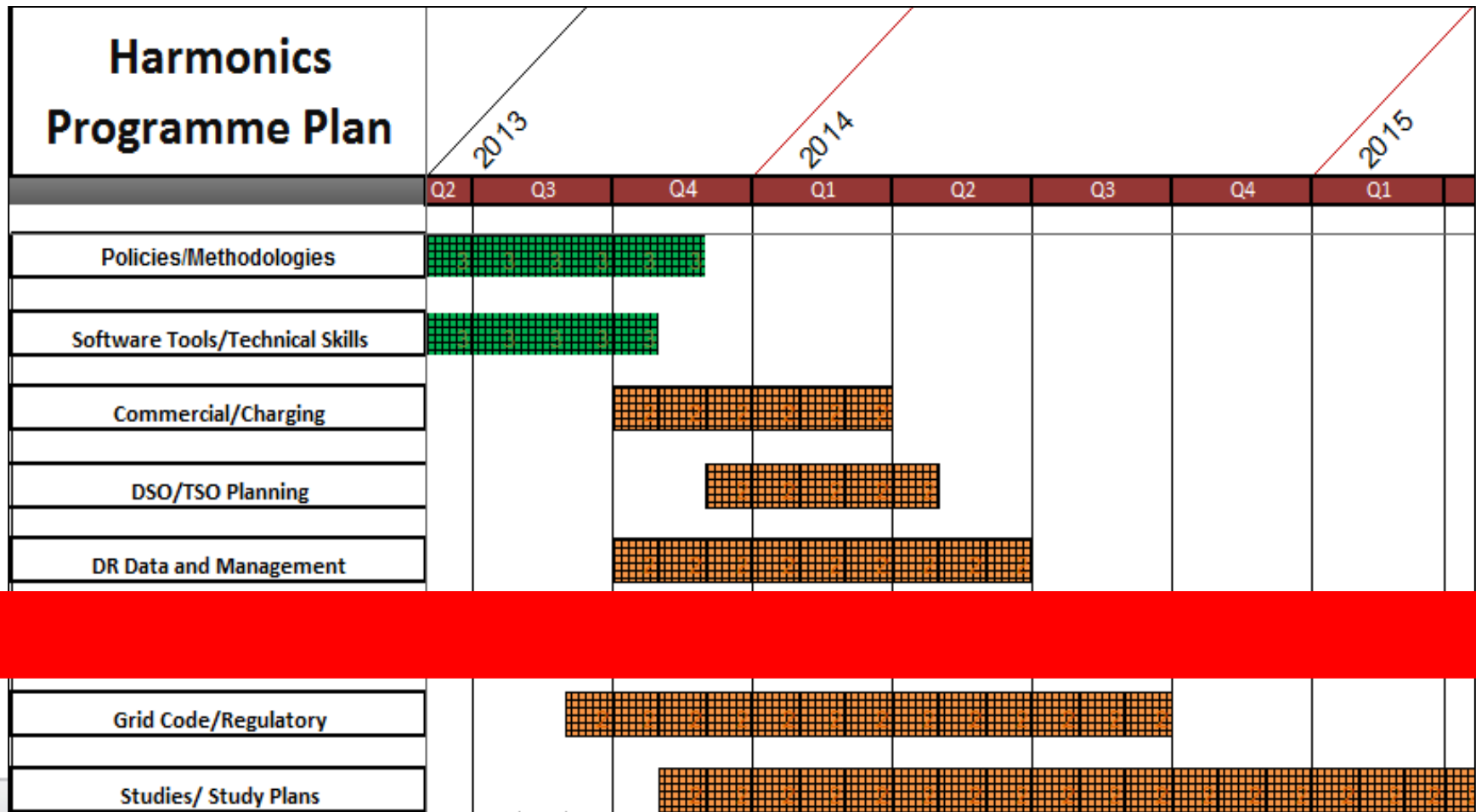

Performance Monitoring and Testing



- Test compliance with the Voltage Harmonic Distortion Limits supplied
- All TSO connections will be tested
- Rules set and Procedures for Grid Code Testing and Performance Monitoring to be reviewed over the coming months
 - At present, Voltage Harmonic Distortion (VHD) levels monitored on ongoing basis



Harmonics Programme Update

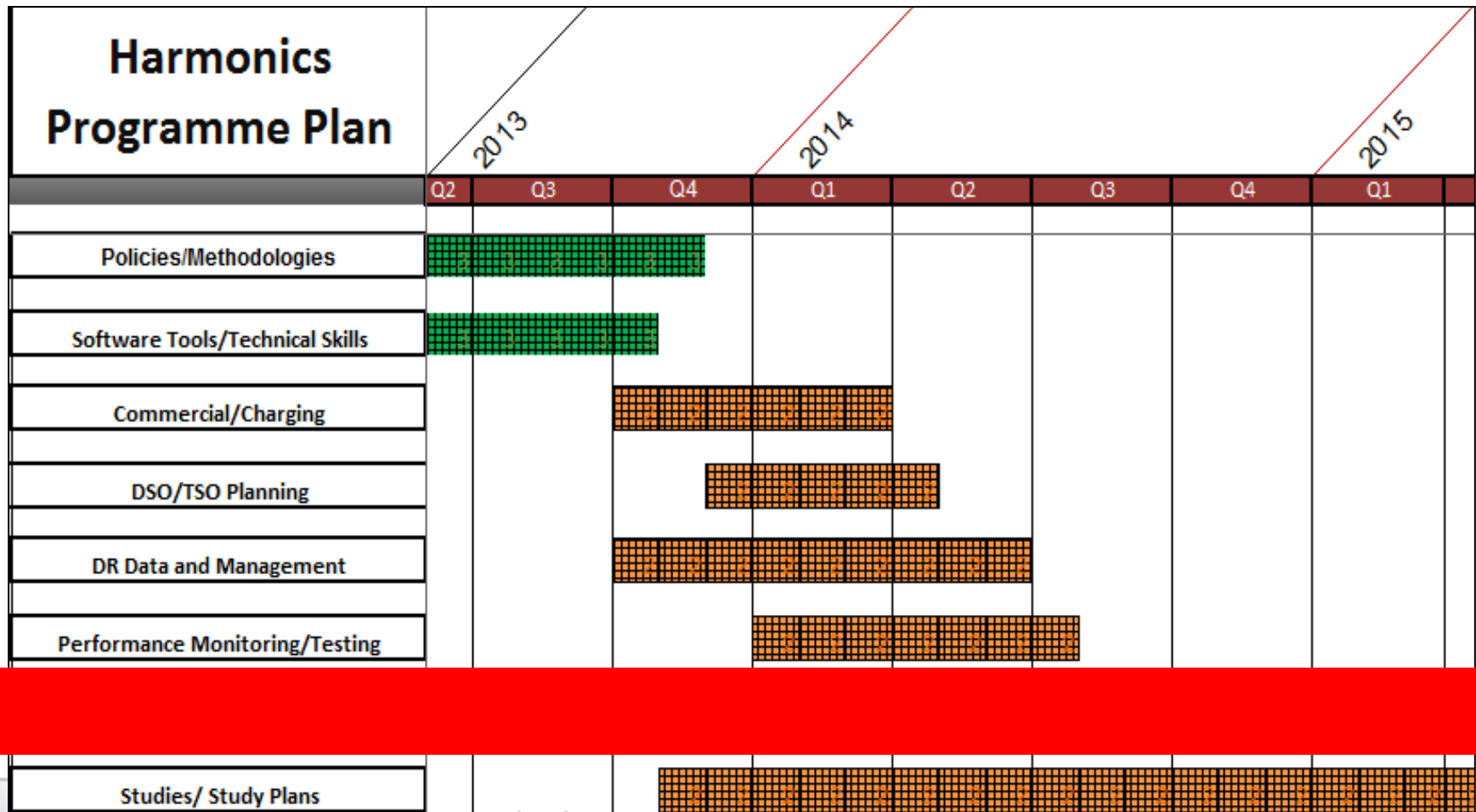

Grid Code/Regulatory



- Presented at Grid Code Review Panel (Ireland)
- To set up All Island Grid Code Working Group on Harmonics
 - Raised at Joint Grid Code Review Panel on 4th December
 - Looking for input from the industry
 - Kick off in the new year
 - With aim of progressing modification to Grid Code(s) in relation to Harmonics
- Align with European Network Codes



Harmonics Programme Update

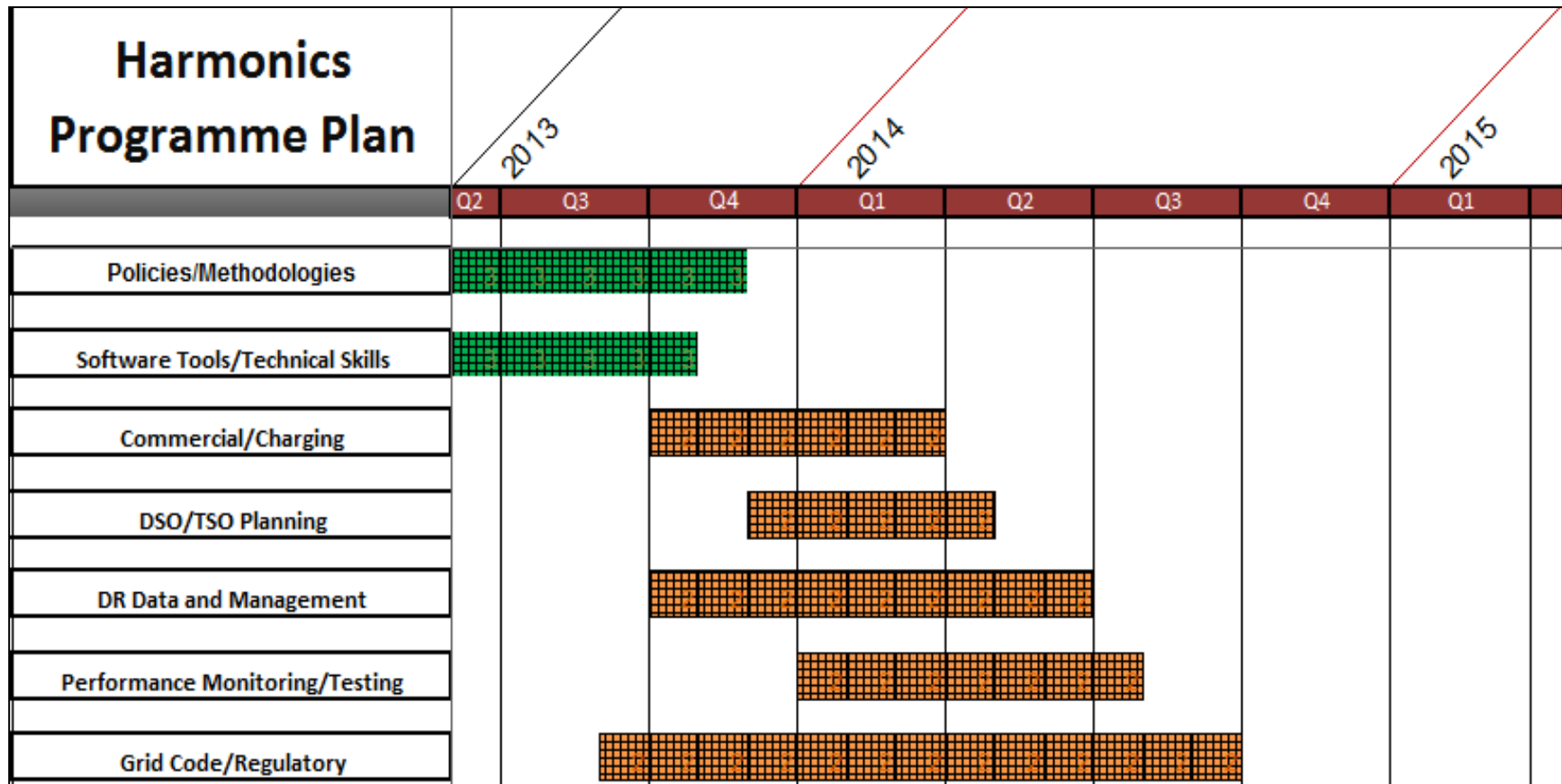

Study Plans



- Two stages to the studies that will be performed by the TSO

Stage 1: Ensure Voltage Harmonic Distortion (VHD) within Planning Levels (customers shallow connection only and formal application to be submitted through Offer Process)

Stage 2: Allocation of VHD Limits to Customers(including VHD allocation at TSO/DSO interface)



Stage 1: Ensure Voltage Harmonic Distortion (VHD) within Planning Levels



- Current Backlog of TSO Studies prioritised based on minimising risk to energisation. Factors considered:
 - Underground Cable (UGC) /Overhead Line (OHL)
 - VHD in Area and System Strength
 - Future Reinforcements in Area
- Once Backlog cleared - Studies Planned in line with Estimated Energisation Dates
 - Screening Studies to be done to assess all future connections
 - Studies (regardless of connection method) will be planned to be performed well in advance of connections
- Co-ordinated TSO/DSO approach for planning studies

Require early notification from customers on any potential change to connection method

Proposed Timelines for Stage 1 Studies



- Context
 - Customer informed on results/requirements well in advance of connection
 - Customer Agreed timelines of 12 months to provide TSO with PED
 - Customer Connection Dates as advised by Customer/Grid Development/DSO

Proposal: Customer to notify SO of change to connection method (UGC) at least 24 months prior to connection

TSO to meet and discuss options for Customers connecting in intervening period

Stage 2: Allocation of VHD Limits to Customers



- VHD Limits Determined via Area Based Studies
 - Customer to advise SO of change to Connection Method at earliest opportunity
 - Influence of other connections in the area on the VHD Limits
 - Allocated at the Point of Common Coupling
- Co-ordinated TSO/DSO approach for planning studies

Stage 2 Studies to be completed well in advance of customer connection

Proposed Timelines for Stage 2 Studies



- Context

- Customer informed of VHD Limits well in advance of connection
- Enough time to pick turbine types or appropriate filters if required
- Customer Agreed timelines of 12 months to provide TSO with PED
- Customer Connection Dates as advised by Customer/Grid Development/DSO
- Studies will be planned to ensure all customers (TSO and DSO) receive VHD Limits well in advance of connection

Proposal: VHD Limits to be allocated to customers at least 18 months prior to connection

TSO to meet and discuss options for Customers connecting in intervening period

Proposed Procedure



Timeframe prior to connection	Customer Obligation	SO Obligation
24 months	<div data-bbox="736 415 1190 682" style="border: 1px solid black; border-radius: 10px; padding: 10px; background-color: #c0392b; color: white; text-align: center;"> Provide details of connection method, particularly for UGC modifications* </div>	<div data-bbox="1286 415 1740 682" style="border: 1px solid black; border-radius: 10px; padding: 10px; background-color: #7ed321; color: white; text-align: center;"> Assess Connection Method. Ensure Planning Levels are not breached. </div>
18 months	<div data-bbox="736 733 1190 1001" style="border: 1px solid black; border-radius: 10px; padding: 10px; background-color: #009688; color: white; text-align: center;"> Ensure VHD Limits are not exceeded at customer connection </div>	<div data-bbox="1286 733 1740 1001" style="border: 1px solid black; border-radius: 10px; padding: 10px; background-color: #673ab7; color: white; text-align: center;"> Provide Customer with VHD Limits, Impedance Loci and Background VHD </div>
12 months	<div data-bbox="736 1052 1190 1319" style="border: 1px solid black; border-radius: 10px; padding: 10px; background-color: #f39c12; color: white; text-align: center;"> Provide PED to SO including report on any harmonics mitigation solution </div>	<div data-bbox="1286 1052 1740 1319" style="border: 1px solid black; border-radius: 10px; padding: 10px; background-color: #a52a2a; color: white; text-align: center;"> Review Application and Solution </div>

* Formal modification through the Offer Programme Required

How studies tie together? – UGC Modifications

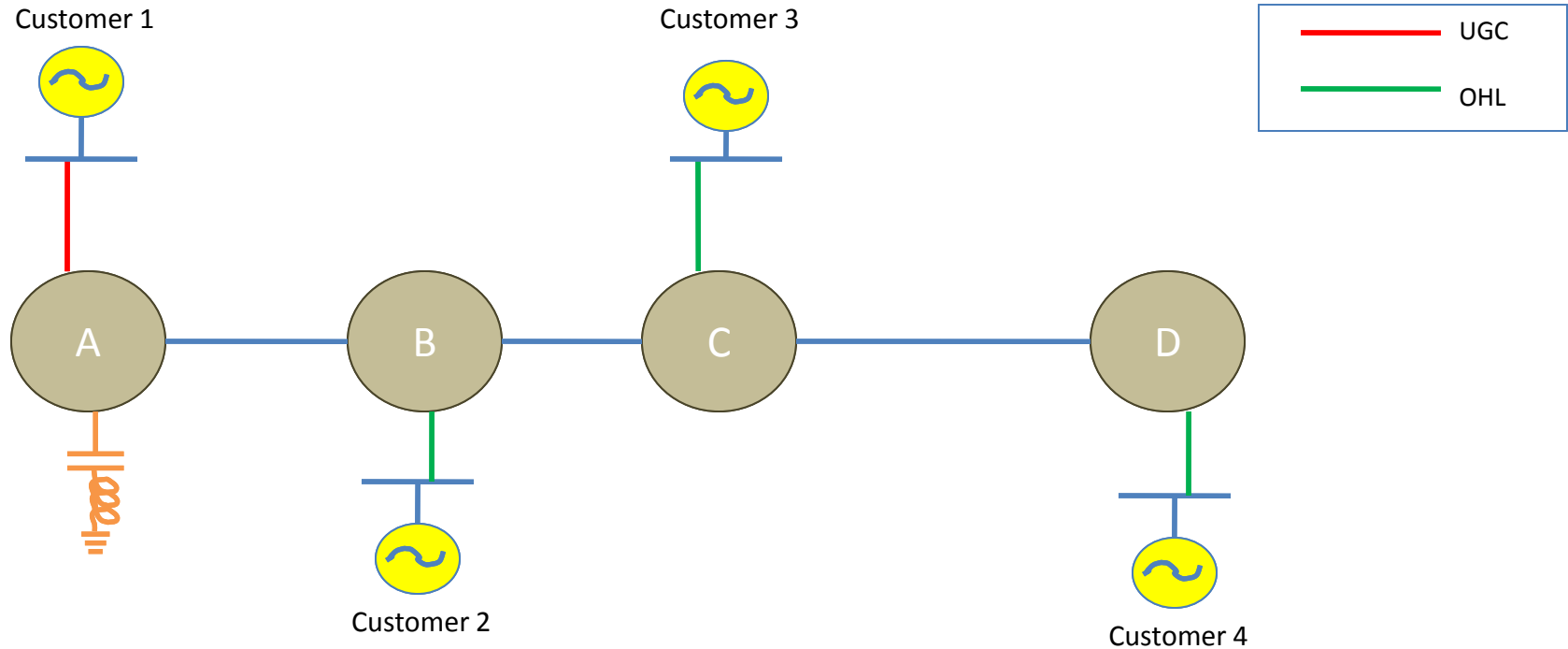

Customer Mod	Stage 1	Stage 2
Customer 1 connecting via UGC in 24 months.	Assess with all future shallow connections in Area. TX reinforcement may be required	Determine VHD Limits for Customer 1 and preliminary limits for all other customers in area

If no more modifications – preliminary limits will become final limits for all customers in area

How studies tie together? - UGC Modifications Sensitivity

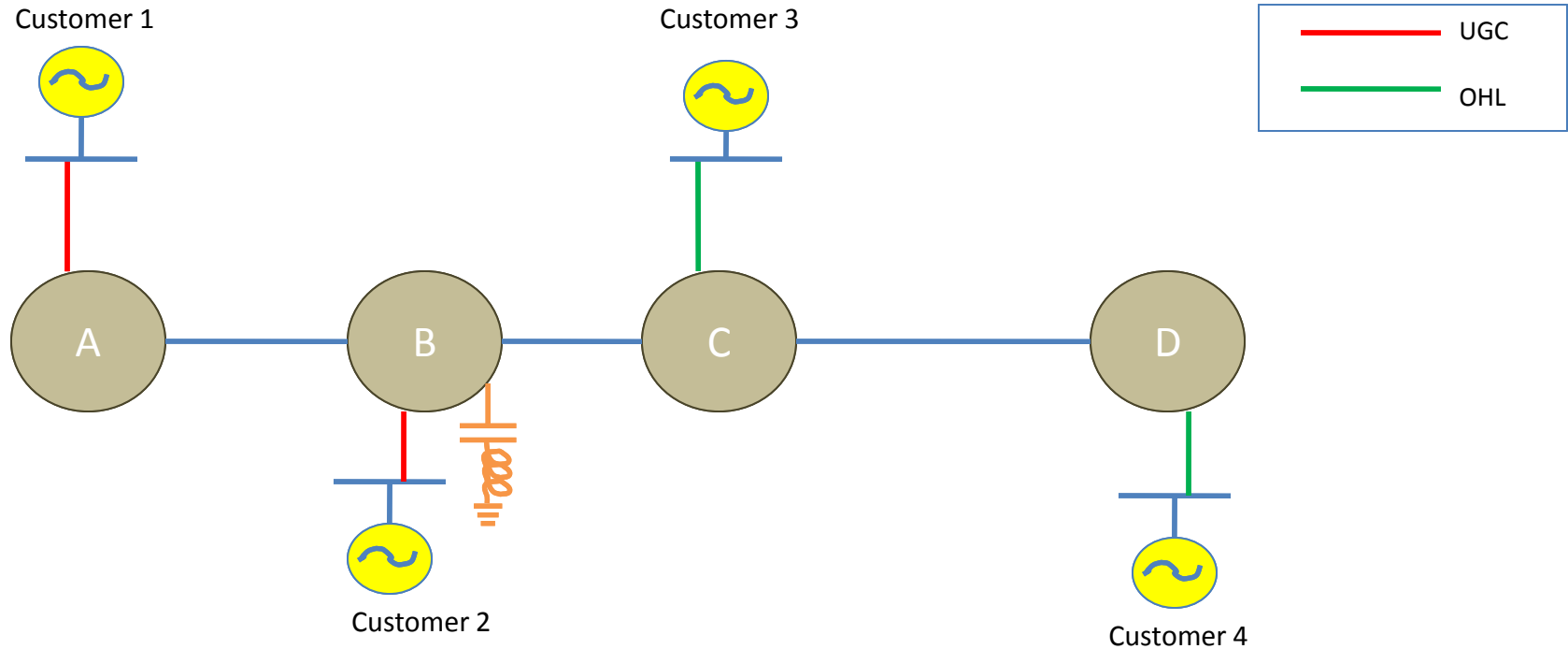

Customer Mod	Stage 1	Stage 2
TSO identify that Customer 2 potentially connect via UGC	Assess with all future connections in Area and Customer 1 & 2 UGC connections. Grouped TX Reinforcement may be required	Determine VHD Limits for Customer 1 & 2 and preliminary limits for other customers

If potential future UGC connections in the area, TSO to identify possible universal solution and communicate to Customers 1 & 2

How studies tie together? All OHL Connections

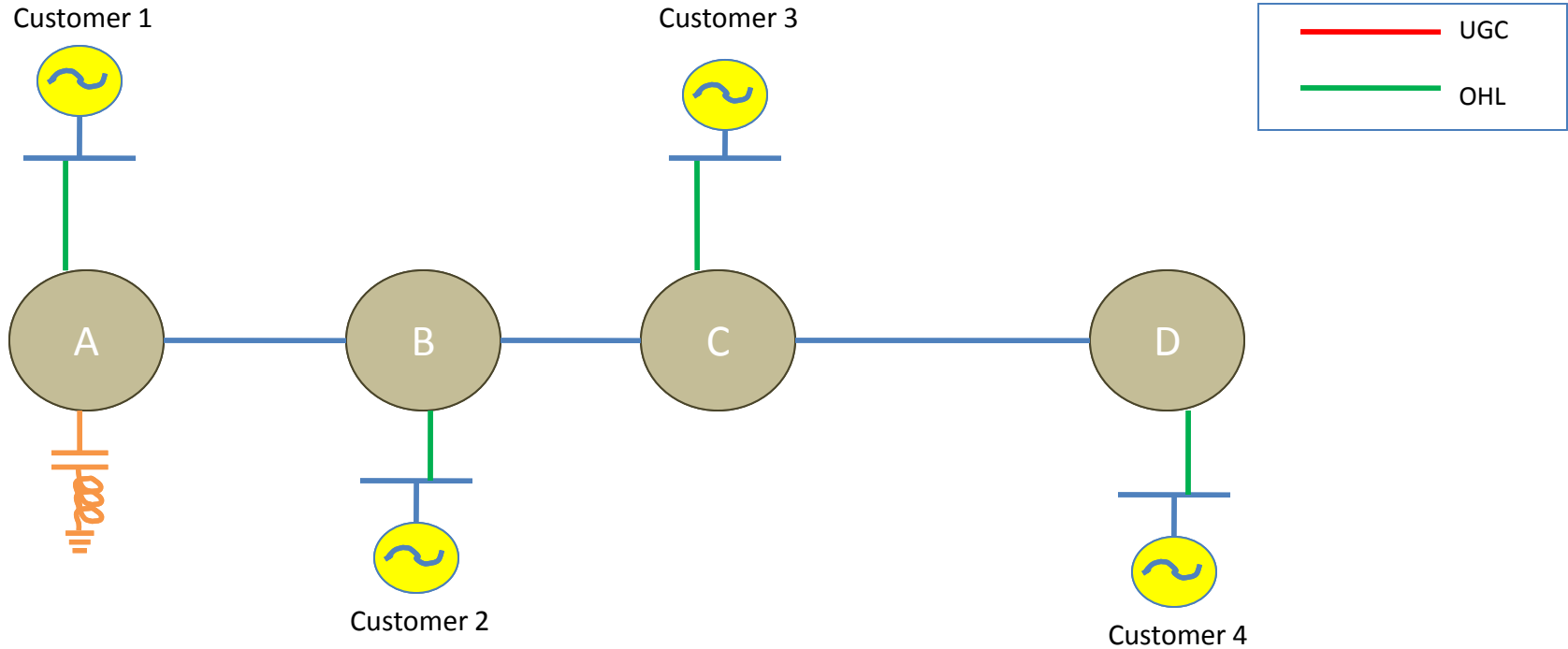

Customer Mod	Stage 1	Stage 2
Customer 1 connecting in 24 months	Assess with all future shallow connections in Area. TX reinforcement may be required	Determine VHD Limits for Customer 1 and preliminary limits for all other customers in area

If no more modifications – preliminary limits from this study will become final limits for all customers in area

What customers will receive?



1. Incremental VHD limit
2. Network Impedance Loci for each Harmonic Order
3. Background VHD at the connecting Node
4. A document outlining the modelling assumptions



VHD limits, Background VHD Impedance Loci from SO



1. VHD Limits and Background VHD

Harmonic Order	Existing Background VHD	VHD Allocation to Customer
3	0.4	0.5
13	0.1	0.3

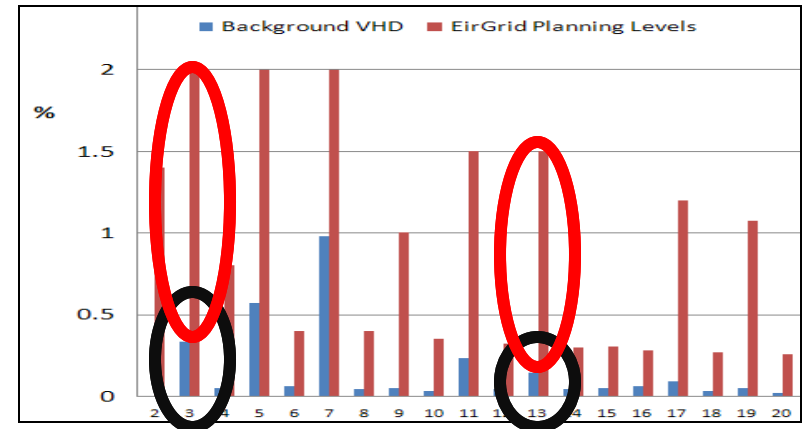

2. Impedance Loci

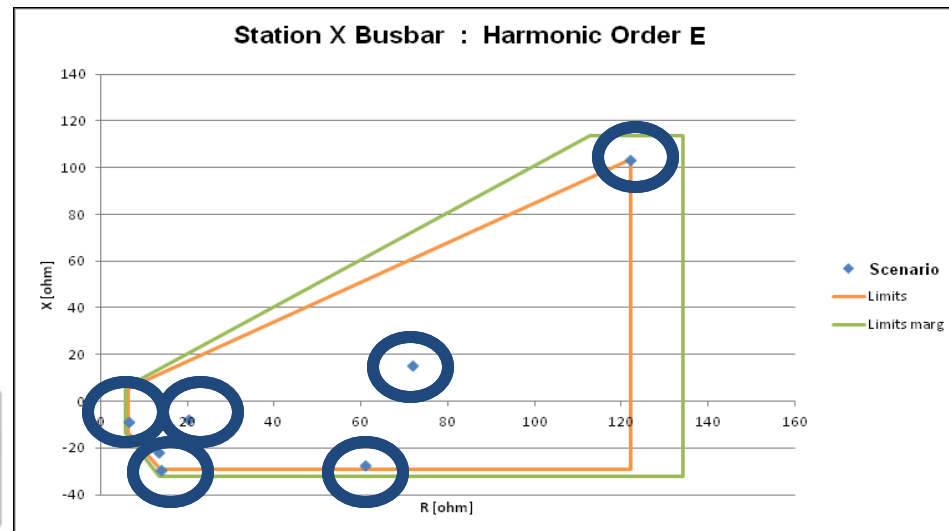

What Customers must do?



Well in advance of connection

Contact the System Operator well in advance of connection informing if connection method will change, particularly to UGC. If the SO is not notified of any change, studies will proceed on best available information

After obtaining VHD Limits, Background VHD and Impedance Loci from the SO, some or all of the following may be required

Procure turbines that have limited harmonic current injections to help meet VHD Limits as allocated by the SO

Determine if Filter or other solution required to you do not breach VHD Limits at the Point of Connection

Communicate the parameters of the solution devices with the System Operator , including technical report of proposed solution



Please forward any queries related to harmonics to the following email address

info@eirgrid.com

